



Chipsmall Limited consists of a professional team with an average of over 10 year of expertise in the distribution of electronic components. Based in Hongkong, we have already established firm and mutual-benefit business relationships with customers from,Europe,America and south Asia,supplying obsolete and hard-to-find components to meet their specific needs.

With the principle of “Quality Parts,Customers Priority,Honest Operation,and Considerate Service”,our business mainly focus on the distribution of electronic components. Line cards we deal with include Microchip,ALPS,ROHM,Xilinx,Pulse,ON,Everlight and Freescale. Main products comprise IC,Modules,Potentiometer,IC Socket,Relay,Connector.Our parts cover such applications as commercial,industrial, and automotives areas.

We are looking forward to setting up business relationship with you and hope to provide you with the best service and solution. Let us make a better world for our industry!



## Contact us

Tel: +86-755-8981 8866 Fax: +86-755-8427 6832

Email & Skype: info@chipsmall.com Web: www.chipsmall.com

Address: A1208, Overseas Decoration Building, #122 Zhenhua RD., Futian, Shenzhen, China



## DIGITAL COMPASS SOLUTION

### Features

- 5° Heading Accuracy, 0.5° Resolution
- 2-axis Capability
- Small Size (19mm x 19mm x 4.5mm), Light Weight
- Advanced Hard Iron Calibration Routine for Stray Fields and Ferrous Objects
- 0° to 70°C Operating Temperature Range
- 2.6 to 5 volt DC Single Supply Operation

### General Description

The Honeywell HMR3100 is a low cost, two-axis electronic compassing solution used to derive heading output. Honeywell's magnetoresistive sensors are utilized to provide the reliability and accuracy of these small, solid state compass designs. The HMR3100 communicates through binary data and ASCII characters at four selectable baud rates of 2400, 4800, 9600, or 19200. This compass solution is easily integrated into systems using a simple USART interface.

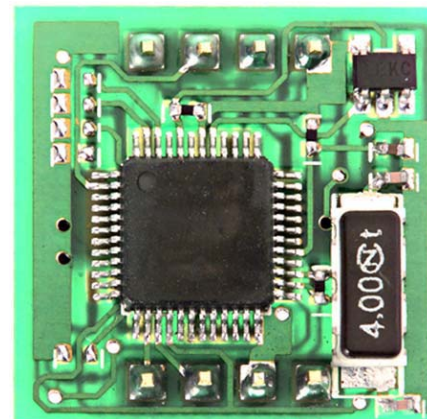
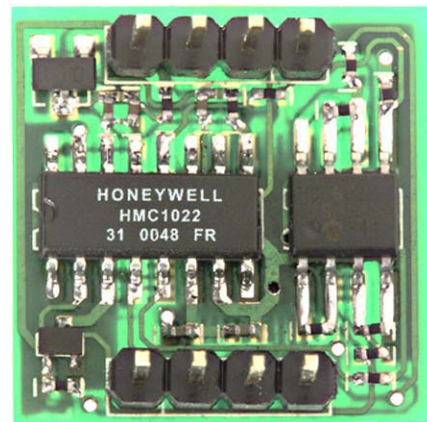

## APPLICATIONS

- Vehicle Compassing
- Hand-Held Electronics
- Telescope Positioning
- Navigation Systems

Block Diagram

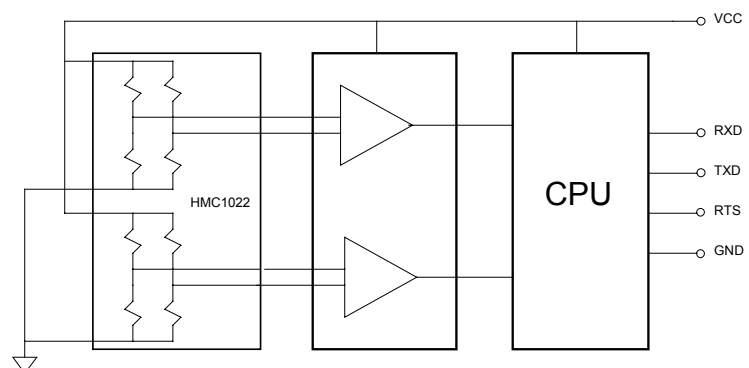



**SPECIFICATIONS**

Characteristics	Conditions	Min	Typ	Max	Units
-----------------	------------	-----	-----	-----	-------

**Heading**

Accuracy	Level		± 5		deg RMS
Resolution			0.5		deg
Repeatability			± 3		deg

**Magnetic Field**

Range	Maximum Magnetic Flux Density		± 2		gauss
Resolution			6		milli-gauss

**Electrical**

Input Voltage	Unregulated	2.6	3	5	volts DC
Current	Normal Mode (Average 1Hz Sampling)	0.1	0.2	0.5	mA
	Sleep Mode			1	µA
	Calibration	6.1	7.3	17.3	mA

**Digital Interface**

USART	USART 9600.N.8.1	2400	9600	19200	Baud
Update Rate	Continuous or Polled	-	2	20	Hz
Connector	8-Pin				-

**Physical**

Dimensions	Circuit Board Assembly		19 x 19 x 4.5		mm
Weight					grams

**Environment**

Temperature	Operating	0	-	+70	°C
	Storage	-40	-	+110	°C

## **Circuit Description**

The HMR3100 Digital Compass Solution circuit board includes the basic magnetic sensors and electronics to provide a digital indication of heading. The HMR3100 has a Honeywell HMC1022 two-axis magnetic sensor on board. The HMR3100 allows users to derive compassing (heading) measurements when the board is in a horizontal (flat) position.

The HMR3100 circuit starts with the HMC1022 two-axis magnetic sensors providing X and Y axis magnetic sensing of the earth's field. These sensors are supplied power by a switching transistor to conserve power with battery operated products. The sensor output voltages are provided to a dual operational amplifier and then to analog to digital converters (ADC) onboard a microcontroller (uC) integrated circuit. The microcontroller integrated circuit periodically samples the amplified sensor voltages, performs the offset corrections, and computes the heading. This microcontroller also performs the external serial data interface and other housekeeping functions such as the calibration routine.

The power supply for the HMR3100 circuit board is to be about a +3 to +5 volt range allowing the user to provide a single lithium battery to logic level supply voltages. The power supply architecture is a single ground system for single ended supply sources (+ and ground return)

## **USART Communication Protocol**

HMR3100 module communicates through binary data and ASCII characters at four selectable baud rates of 2400, 4800, 9600, or 19200. The default data bit format is USART 9600.N.8.1. The baud rate selection is determined by the position of jumpers J1 and J3. These jumpers are zero ohm SMT resistors (jumpers) and are normally high (logic 1) when removed, and grounded (logic 0) when in place. At 2400 baud, no jumpers are present for a 1,1 logic presentation. At 4800 baud J3 is present for a 1,0 logic presentation. The factory default setting of 9600 baud is created by a jumper present on J1 for a 0,1 logic presentation. With J1 and J3 jumpers present for a 0,0 logic presentation, the compass module works at 19200 baud. See Figure 5 for jumper locations. Jumper J2 is for factory testing, and J4 is for X-axis inverse should the end-item mount the HMR3100 module upside down.

The HMR3100 is ready to output heading information when the board is powered up. Note that when the device is first powered up, it may need calibration. The HMR3100 has three modes of operation described as normal, continuous, and calibration.

## Normal Mode

When the host processor (external to the HMR3100) sends a RTS low pulse to the RTS pin, the HMR3100 will send heading data via the TXD pin. The host shall hold the RXD pin high during this mode. The RTS shall be held high when not pulsed. The HMR3100 will return to sleep status when RTS is left high after the data is sent. Up to 20 heading queries per second can be accomplished given fast enough baud rates. A caution is advised that average current draw is proportional to supply voltage and amount of queries handled. At the 20 Hz rate, 1 to 5 milliamperes of current is consumed with lesser query rates taking advantage of the less than one microampere sleep mode current draw between queries. Figure 1 shows the normal mode timing diagram.

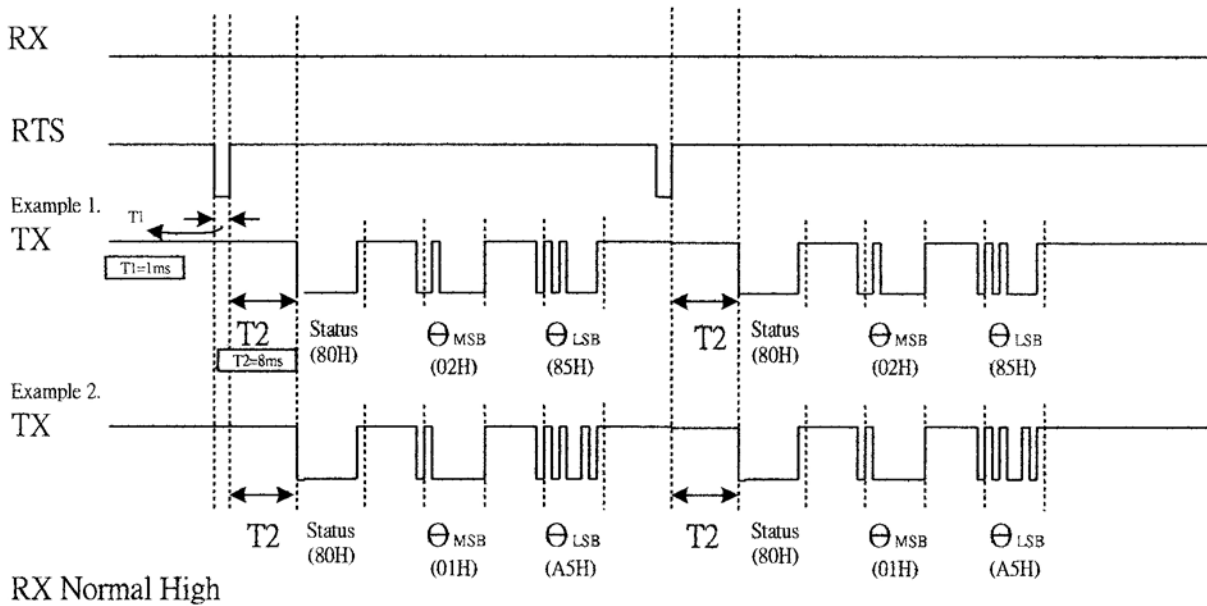

Figure 1  
Normal Mode Timing Diagram

## Continuous Mode

When the host processor sets the RTS pin to a low level position, the HMR3100 will continuously stream heading data via the TXD pin. Note that the processor does not return to sleep mode and outputs heading slightly below a 2 Hz rate. Figure 2 shows the continuous mode timing diagram.

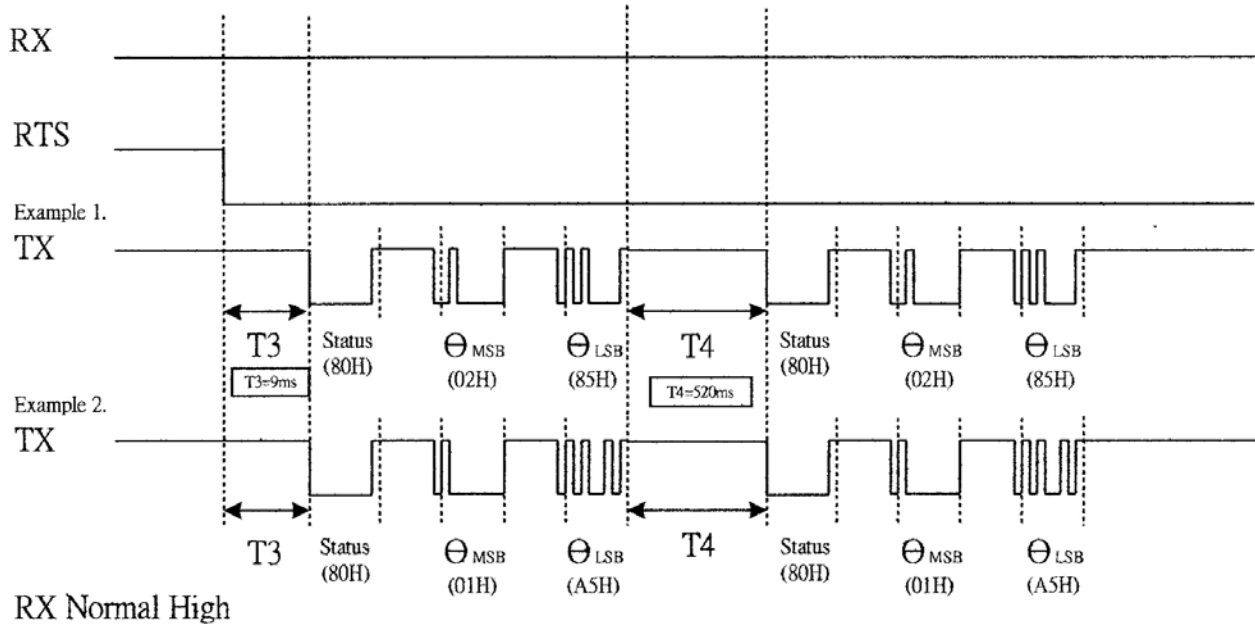

Figure 2  
Continuous Mode Timing Diagram

## Calibration Mode

When the host processor pulses the RTS pin, and sends the RXD pin to a low logic level, the HMR3100 is in calibration mode. At a moderate rate (2 to 5 seconds per rotation), rotate the HMR3100/host assembly two complete circles to allow the HMR3100 to take measurements for compass calibration. At the completion of the rotations, return the RXD to a high logic level. The HMR3100 will return to sleep status until another mode has been initiated. Upon initiation of the calibration mode, the microcontroller shall output a STA (53 54 41 hex) indicating a start of calibration and then RDY (52 44 59 hex) at the completion of the rotations and the RXD line returning high. Figure 3 shows the calibration mode timing diagram.

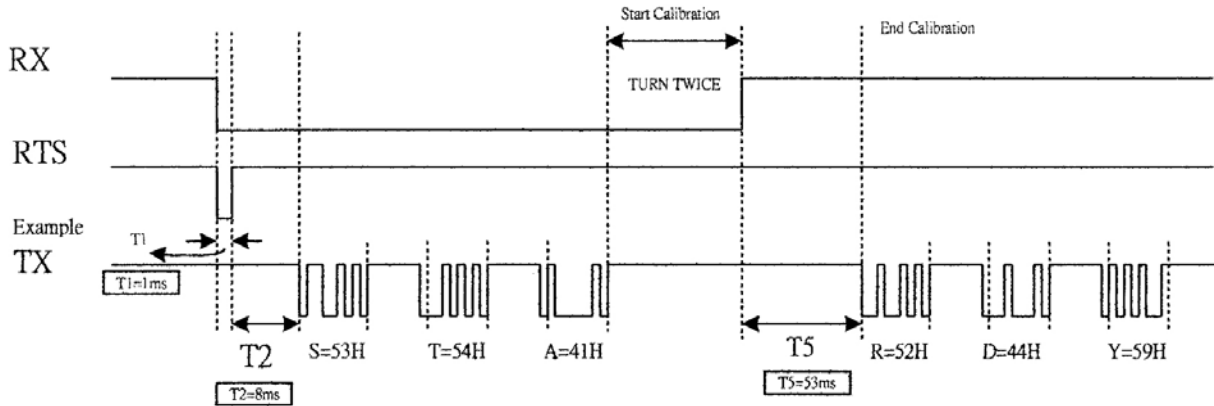

Figure 3  
Calibration Mode Timing Diagram

## Data Description

The HMR-3100 host processor uses a three byte reply as the RTS line is brought low. The data is formatted in hexadecimal (hex) fashion with the first byte being either 80(hex) or 81(hex). If that first byte LSbit is flagged high (81 hex), it means magnetic distortion maybe present and a calibration should be performed. The remaining two bytes are the heading (in degrees) in MSB to LSB format. There is some data interpretation needed to derive the heading. For example, an 80 02 85 (hex) Byte pattern correlates to 322.5 degrees.

This is done by taking the MSB hex value, converting it to decimal representation (e.g. 02 decimal) and multiplying it by 256. Then the LSB is decimalized (e.g. 85(hex) to 133(decimal)) and added to the 512(decimal) MSB. The total (512+133=645) is then divided by two to arrive at a 322.5 degree heading. This data format permits the 0.5° resolution.

## Development Kit

The HMR3100 Development Kit includes additional hardware and Windows demo program software to form a development kit for electronic compassing. This kit includes the appropriate HMR3100 Printed Circuit Board (PCB) module soldered to an intermediate circuit board using a wide DIP-style (0.8" spacing) pin arrangement. The intermediate board assembly plugs into an RS-232 motherboard with a serial port connector. In addition, a four-foot serial port cable (RJ-11 to D-9F), nine-volt battery clip, demo program software, and user's guide is included. The RS-232 motherboard incorporates a 5 volt regulator integrated circuit to provide the necessary voltages to the onboard RS-232 converter integrated circuit and the HMR3100 daughter-board. A nine-volt battery clip is included, but other DC input voltages between 7 and 15 volts may be used. Supply currents are nominally around 8 milliamperes plus the HMR3100 current draw.

The RS-232 motherboard also contains a six-contact modular jack (RJ-11) for a compact RS-232 interface to a personal computer serial port. Ground, RTS, RXD, and TXD data lines are brought out to the jack with two contacts left open. Figure 4 shows the kit board assemblies.

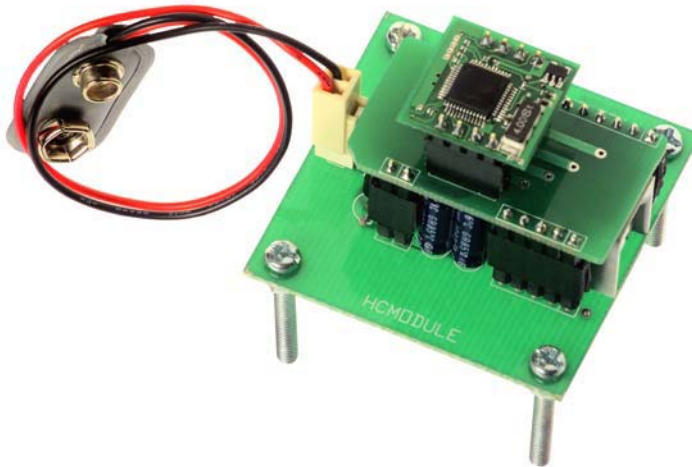
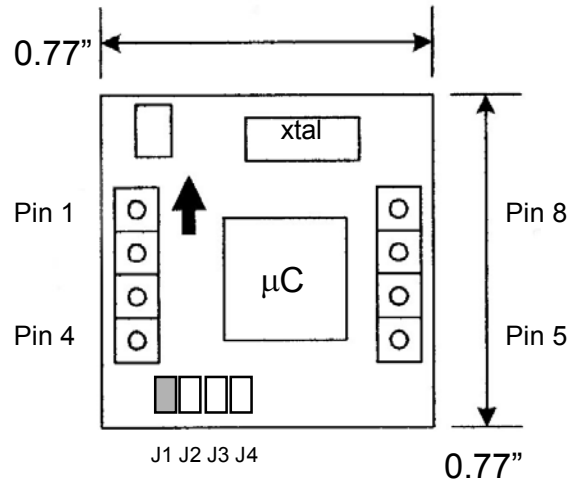

Figure 4  
HMR3100 Kit Hardware



## Pin Configuration

Pin Number	Pin Name	Description
1	VCC	Power Supply Input
2	NC	No Connection
3	RTS	Ready To Send Input
4	NC	No Connection
5	TXD	Transmit Data Output
6	RXD	Receive Data Input
7	GND	Power and Signal Ground
8	NC	No Connection



Top Side

Figure 5  
HMR3100 Pinout

## Ordering Information

Ordering Number	Product
HMR3100	PCB Module Only
HMR3100-Demo-232	PCB Module with Development Kit

Honeywell reserves the right to make changes to improve reliability, function or design. Honeywell does not assume any liability arising out of the application or use of any product or circuit described herein; neither does it convey any license under its patent rights nor the rights of others.