



Chipsmall Limited consists of a professional team with an average of over 10 year of expertise in the distribution of electronic components. Based in Hongkong, we have already established firm and mutual-benefit business relationships with customers from,Europe,America and south Asia,supplying obsolete and hard-to-find components to meet their specific needs.

With the principle of “Quality Parts,Customers Priority,Honest Operation,and Considerate Service”,our business mainly focus on the distribution of electronic components. Line cards we deal with include Microchip,ALPS,ROHM,Xilinx,Pulse,ON,Everlight and Freescale. Main products comprise IC,Modules,Potentiometer,IC Socket,Relay,Connector.Our parts cover such applications as commercial,industrial, and automotives areas.

We are looking forward to setting up business relationship with you and hope to provide you with the best service and solution. Let us make a better world for our industry!



Contact us

Tel: +86-755-8981 8866 Fax: +86-755-8427 6832

Email & Skype: info@chipsmall.com Web: www.chipsmall.com

Address: A1208, Overseas Decoration Building, #122 Zhenhua RD., Futian, Shenzhen, China



HPDL-1414

Four Character Smart Alphanumeric Displays



Data Sheet

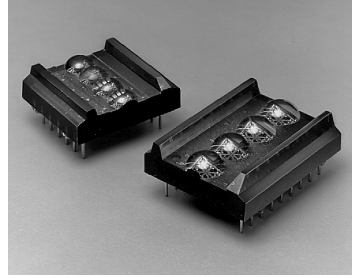

Description

The HPDL-1414 is a smart, four character, sixteen-segment, red GaAsP display. The HPDL-1414 has a character height of 2.85 mm (0.112"). The on-board CMOS IC contains memory, ASCII decoder, multiplexing circuitry and drivers. The monolithic LED characters are magnified by an immersion lens which increases both character size and luminous intensity. The encapsulated dual-in-line package provides a rugged, environmentally sealed unit.

The HPDL-1414 incorporates many improvements over competitive products. It has a wide operating temperature range, very fast IC access time, and improved ESD protection. The displays are also fully TTL compatible, wave solderable, and highly reliable. These displays are ideally suited for industrial and commercial applications where a good-looking, easy-to-use alphanumeric display is required.

Features

- **Smart alphanumeric display**
Built-in RAM, ASCII decoder and LED drive circuitry
- **Wide operating temperature range**
-40°C to +85°C
- **Fast access time**
160 ns
- **Excellent ESD protection**
Built-in input protection diodes
- **CMOS IC for low power consumption**
- **Full TTL compatibility over operating temperature range**
 $V_{IL} = 0.8\text{ V}$
 $V_{IH} = 2.0\text{ V}$
- **Wave solderable**
- **Rugged package construction**
- **End-stackable**
- **Wide viewing angle**

Typical Applications

- Portable data entry devices
- Medical equipment
- Process control equipment
- Test equipment
- Industrial instrumentation
- Computer peripherals
- Telecommunication instrumentation

ESD WARNING: STANDARD CMOS HANDLING PRECAUTIONS SHOULD BE OBSERVED WITH THE HPDL-1414.

Absolute Maximum Ratings

Supply Voltage, V_{DD} to Ground -0.5 V to 7.0 V
 Input Voltage, Any Pin to Ground -0.5 V to $V_{DD} + 0.5$ V
 Free Air Operating Temperature Range, $T_A^{[1]}$ -40°C to +85°C
 Relative Humidity (non-condensing) at 65°C 90%
 Storage Temperature, T_S -40°C to +85°C
 Wave Solder Temperature,
 1.59 mm (0.063 in.) below Body 250°C for 3 secs
 ESD Protection @ 1.5 k Ω , 100 pF $V_Z = 2$ kV (each Pin)

Package Dimensions

HPDL-1414

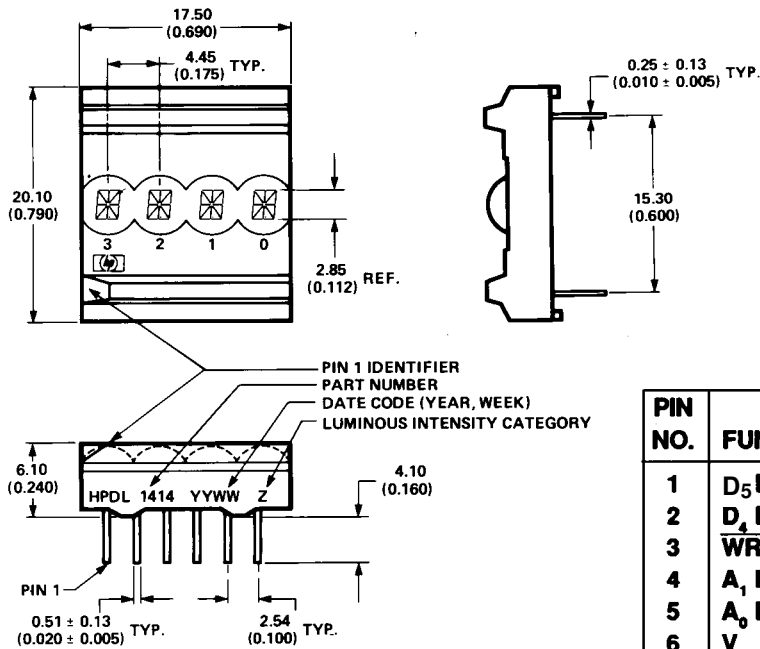

PIN NO.	FUNCTION	PIN NO.	FUNCTION
1	D ₅ DATA INPUT	7	GND
2	D ₄ DATA INPUT	8	D ₀ DATA INPUT
3	\overline{WR} WRITE	9	D ₁ DATA INPUT
4	A ₁ DIGIT SELECT	10	D ₂ DATA INPUT
5	A ₀ DIGIT SELECT	11	D ₃ DATA INPUT
6	V _{DD}	12	D ₆ DATA INPUT

NOTES:

- UNLESS OTHERWISE SPECIFIED, THE TOLERANCE ON ALL DIMENSIONS IS 0.254 mm (0.010 in.).
- DIMENSIONS IN mm (inches).

Recommended Operating Conditions

Parameter	Sym.	Min.	Nom.	Max.	Units
Supply Voltage	V _{DD}	4.5	5.0	5.5	V

DC Electrical Characteristics

Parameter	Sym.	Min.	25°C Typ.	25°C Max.	Units	Test Conditions
Input Current	I _{IL}		45	100	μA	V _{DD} = 5.0 V, V _{IL} = 0.8 V
I _{DD} Blank	I _{DD} (BL)		1.5	2.7	mA	V _{DD} = 5.0 V, BL = 0.8 V
I _{DD} 4 Digits ON (10 Segments per digit) ^[1,2]	I _{DD}		70	90	mA	V _{DD} = 5.0 V
Input Voltage High	V _{IH}	2.0			V	
Input Voltage Low	V _{IL}	GND		0.8	V	
Power Dissipation ^[3]	P _D		350	450	mW	V _{DD} = 5.0 V

Notes:

1. “%” illuminated in all four characters.
2. Measured at five seconds.
3. Power Dissipation = (V_{DD})(I_{DD}) for 10 segments ON.

Optical Characteristics at 25°C^[6]

Parameter	Sym.	Min.	Typ.	Units	Test Conditions
Peak Luminous Intensity per Digit, 8 segments ON (character average)	I _V Peak	0.4	1.0	mcd	V _{DD} = 5.0 V, “*” illuminated in all 4 digits
Peak Wavelength	λ _{Peak}		655	nm	
Dominant Wavelength	λ _d		640	nm	
Off Axis Viewing Angle			± 40	degrees	

AC Timing Characteristics over Operating Temperature Range at $V_{CC} = 4.5\text{ V}$

Parameter	Symbol	-20°C t_{MIN}	25°C t_{MIN}	70°C t_{MIN}	Units
Address Setup Time	t_{AS}	90	115	150	ns
Write Delay Time	t_{WD}	10	15	20	ns
Write Time	t_W	80	100	130	ns
Data Setup Time	t_{DS}	40	60	80	ns
Data Hold Time	t_{DH}	40	45	50	ns
Address Hold Time	t_{AH}	40	45	50	ns
Access Time		130	160	200	ns

Timing Diagram

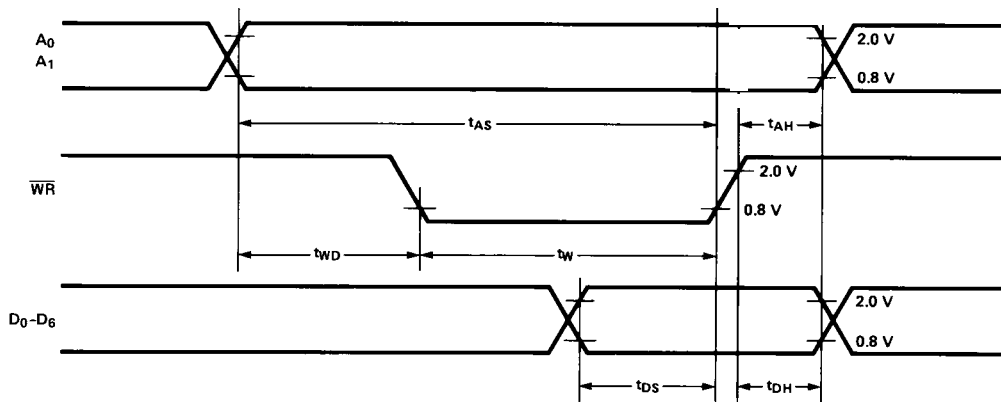

Character Set

BITS		D ₃	D ₂	D ₁	D ₀														
		0	0	0	0	0	0	0	0	1	1	1	1	1	1	1	1		
		0	0	0	0	1	1	1	1	0	0	0	0	1	1	1	1		
		0	0	1	1	0	0	1	1	0	0	1	1	0	0	1	1		
		0	1	0	1	0	1	0	1	0	1	0	1	0	1	0	1		
D ₆	D ₅	D ₄	HEX	0	1	2	3	4	5	6	7	8	9	A	B	C	D	E	F
0	1	0	2	(space)	!	"	#	\$	%	&	'	<	>	*	+	,	-	.	/
0	1	1	3	0	1	2	3	4	5	6	7	8	9	=	/	<	=	>	?
1	0	0	4	a	A	B	C	D	E	F	G	H	I	J	K	L	M	N	O
1	0	1	5	P	Q	R	S	T	U	V	W	X	Y	Z	[\]	^	_

Magnified Character Font Description

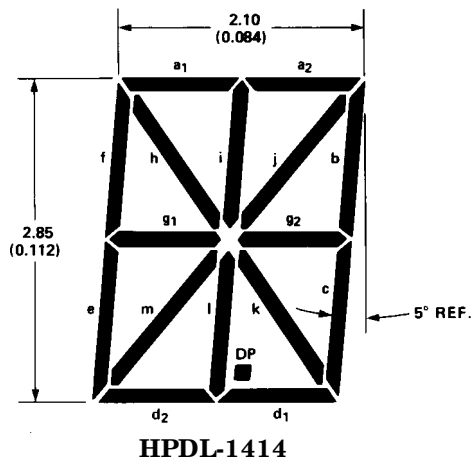

Electrical Description

Display Internal Block Diagram HPDL-1414

Figure 1 shows the internal block diagram of the HPDL-1414. It consists of two parts: the display LEDs and the CMOS IC. The CMOS IC consists of a four-word ASCII memory, a 64-word character generator, 17 segment drivers, four digit drivers, and the scanning circuitry necessary to multiplex the four monolithic LED characters. In normal

operation, the divide-by-four counter sequentially accesses each of the four RAM locations and simultaneously enables the appropriate display digit driver. The output of the RAM is decoded by the character generator which, in turn, enables the appropriate display segment drivers. Seven-bit ASCII data is stored in RAM. Since the display uses a 64-character decoder, half of the possible 128 input combinations are invalid. For each display location where $D_5 = D_6$ in the

ASCII RAM, the display character is blanked.

Data Entry HPDL-1414

Figure 2 shows a truth table for the HPDL-1414. Data is loaded into the display through the DATA inputs (D_6-D_0), ADDRESS inputs (A_1-A_0), and WRITE (\overline{WR}). After a character has been written to memory, the IC decodes the ASCII data, drives the display and refreshes it without any external hardware or software.

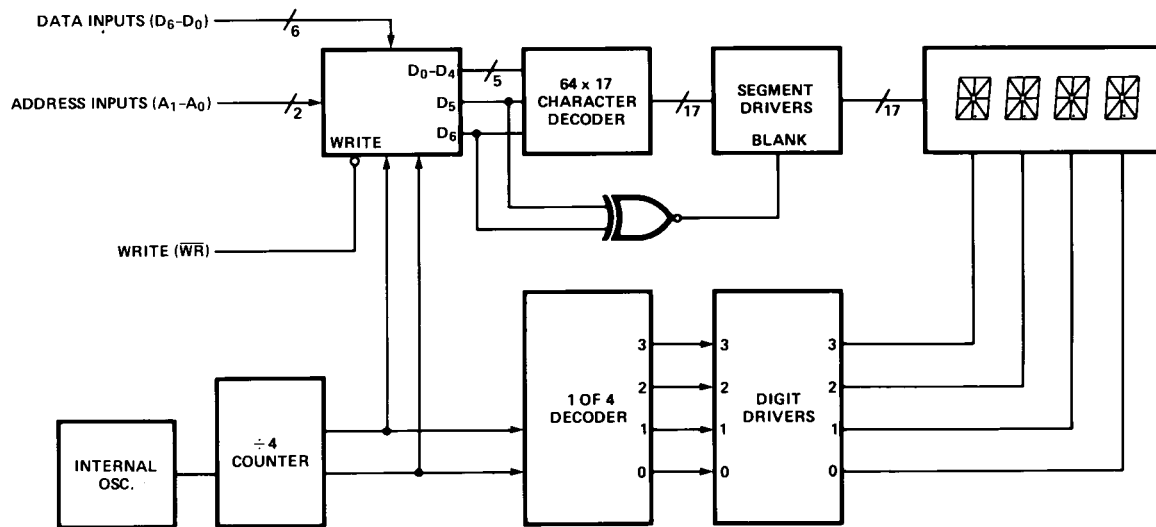

Figure 1. HPDL-1414 Internal Block Diagram.

\overline{WR}	A_1	A_0	D_6	D_5	D_4	D_3	D_2	D_1	D_0	DIG_3	DIG_2	DIG_1	DIG_0
L	L	L	a	a	a	a	a	a	a	NC	NC	NC	A
L	L	H	b	b	b	b	b	b	b	NC	NC	B	NC
L	H	L	c	c	c	c	c	c	c	NC	C	NC	NC
L	H	H	d	d	d	d	d	d	d	D	NC	NC	NC
H	X	X	X	X	X	X	X	X	X	Previously Written Data			

L = LOGIC LOW INPUT

H = LOGIC HIGH INPUT

X = DON'T CARE

"a" = ASCII CODE CORRESPONDING TO SYMBOL "A"

NC = NO CHANGE

Figure 2. HPDL-1414 Write Truth Table.

Optical Considerations/ Contrast Enhancement

The HPDL-1414 display uses a precision aspheric immersion lens to provide excellent readability and low off-axis distortion. The aspheric lens produces a magnified character height of 2.85 mm (0.112 in.) and a viewing angle of $\pm 40^\circ$. These features provide excellent readability at distances up to 1.5 metres (4 feet).

Each display is tested for luminous intensity and marked with an intensity category on the side of the display package. To ensure intensity matching for multiple package applications, mixing intensity categories for a given panel is not recommended.

The display is designed to provide maximum contrast when placed behind an appropriate contrast enhancement filter. For further information on contrast enhancement, see Application Note 1015.

Mechanical and Electrical Considerations

The HPDL-1414 is a dual in-line package that can be stacked horizontally and vertically to create arrays of any size. These displays are designed to operate continuously between -40°C to $+85^\circ\text{C}$ with a maximum of 10 segments on per digit.

The HPDL-1414 is assembled by die attaching and wire bonding the four GaAsP/GaAs monolithic LED chips and the CMOS IC to a printed circuit board. An immersion lens is formed by placing the PC board assembly into a nylon lens filled with epoxy. Backfill epoxy environmentally seals the display package. This package construction provides the display with a high tolerance to temperature cycling.

The inputs to the CMOS IC are protected against static discharge and input current latchup. However, for best results standard CMOS handling precautions should be used. Prior to use, the HPDL-1414 should be stored in anti-static tubes or conductive material. During assembly a grounded conductive work area should be used, and assembly personnel should wear conductive wrist straps. Lab coats made of synthetic material should be avoided since they are prone to static charge build-up. Input current latchup is caused when the CMOS inputs are subjected either to a voltage below ground ($V_{IN} < \text{ground}$) or to a voltage higher than V_{DD} ($V_{IN} > V_{DD}$) and when a high

current is forced into the input. To prevent input current latchup and ESD damage, unused inputs should be connected either to ground or to V_{DD} . Voltages should not be applied to the inputs until V_{DD} has been applied to the display. Transient input voltages should be eliminated.

Soldering and Post Solder Cleaning Instructions

The HPDL-1414 may be hand soldered or wave soldered with SN63 solder. Hand soldering may be safely performed only with an electronically temperature-controlled and securely grounded soldering iron. For best results, the iron tip temperature should be set at 315°C (600°F). For wave soldering, a rosin-based RMA flux can be used. The solder wave temperature should be $245^\circ\text{C} \pm 5^\circ\text{C}$ ($473^\circ\text{F} \pm 9^\circ\text{F}$), and the dwell in the wave should be set at $1\frac{1}{2}$ to 3 seconds for optimum soldering. Preheat temperature should not exceed 93°C (200°F) as measured on the solder side of the PC board.

For further information on soldering and post solder cleaning, see Application Note 1027, *Soldering LED Components*.

Intensity Bin Limits

Bin	Intensity Range (mcd)	
	Min.	Max.
E	0.43	0.58
F	0.50	0.70
G	0.59	0.84
H	0.71	1.01
I	0.85	1.24
J	1.02	1.52
K	1.23	1.83

Note:

Test conditions as specified in Optical Characteristic table.

For product information and a complete list of distributors, please go to our website: www.avagotech.com

Avago, Avago Technologies, and the A logo are trademarks of Avago Technologies Limited in the United States and other countries.
Data subject to change. Copyright © 2006 Avago Technologies Limited. All rights reserved. Obsoletes 5988-1652EN
5988-3271EN June 25, 2006

