



Chipsmall Limited consists of a professional team with an average of over 10 year of expertise in the distribution of electronic components. Based in Hongkong, we have already established firm and mutual-benefit business relationships with customers from,Europe,America and south Asia,supplying obsolete and hard-to-find components to meet their specific needs.

With the principle of “Quality Parts,Customers Priority,Honest Operation,and Considerate Service”,our business mainly focus on the distribution of electronic components. Line cards we deal with include Microchip,ALPS,ROHM,Xilinx,Pulse,ON,Everlight and Freescale. Main products comprise IC,Modules,Potentiometer,IC Socket,Relay,Connector.Our parts cover such applications as commercial,industrial, and automotives areas.

We are looking forward to setting up business relationship with you and hope to provide you with the best service and solution. Let us make a better world for our industry!



Contact us

Tel: +86-755-8981 8866 Fax: +86-755-8427 6832

Email & Skype: info@chipsmall.com Web: www.chipsmall.com

Address: A1208, Overseas Decoration Building, #122 Zhenhua RD., Futian, Shenzhen, China



NEW

Miniature Waterproof Plastic Connectors

HR30 Series



Mated dimensions

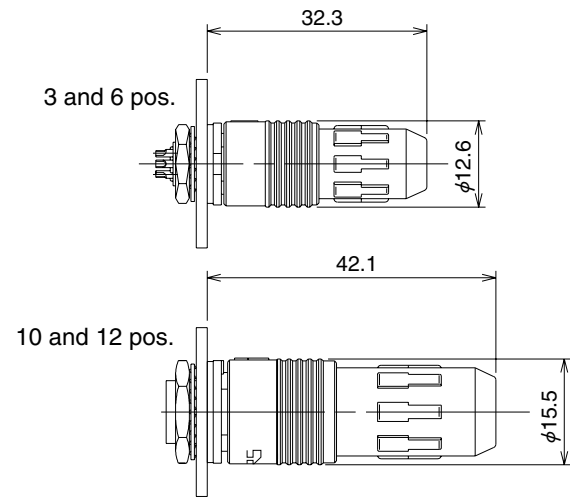

■ Features

1. Small size

Short in length when fully terminated and mated.

2. Water and dust protected

IP67 protection rating: Complete protection against dust penetration and against water penetration when submerged 1 meter deep for half hour. Mated with corresponding connector or protective cap.

3. Simple pull lock release

Built-in lock/release mechanism securely locks mated connectors while allowing quick disconnection by simply pulling on the plug's release collar. Molded-in grooves prevent hand slippage when pulled.

The round configuration of the collar allows easy side-by-side panel mounting and will not snag on objects when the cable is pulled-out.

4. Light weight, corrosion resistant

Glass reinforced thermoplastic compounds and non-corrosive components are used in all assemblies.

5. Contact protection and self-alignment

Multiple polarizing keys protect the contacts from misalignment or attempted insertion of the wrong connector, while assuring correct mating between the corresponding connectors.

6. Visual alignment indicators

Permanent alignment indicators in a contrasting color on all connectors aid in correct alignment and engagement.

7. Built-in cable strain relief

■ Applications

Test and measuring equipment, portable devices, instrumentation, industrial devices, recreational equipment, I/O applications and other applications requiring use of lightweight, corrosion resistant quick mate/ release cable connections.

Lock/release operation

Push-pull- single action lock

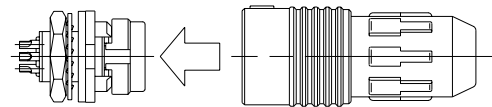

■Product Specifications

Ratings	Current rating	5A (3 pos.) 2A (6,10,12 pos.)	Operation Temperature Range	-25°C to +85°C
	Voltage rating	100V AC,140V DC(3,6 pos.) 30V AC,42V DC(10,12 pos.)	Storage Temperature Range	-25°C to +85°C

Characteristic	Specification	Conditions
1.Contact resistance	5m ohms max. (3 pos.) 15m ohms max. (Solder type: 6, 10, and 12 pos.) 30m ohms max. (Through hole type: 6 and 12 pos.)	1A DC
2.Insulation resistance	1000M ohms min.	100 V DC
3.Withstanding voltage	No flashover or insulation breakdown	300 V AC / one minute
4.Vibration	No electrical discontinuity of 10 μs or more	Frequency: 10 to 55 Hz, single amplitude of 0.75 mm, 2 hours in each of the 3 directions
5.Durability (mating/un-mating)	Contact resistance 10m ohms min.(3 pos.) Contact resistance 30m ohms min. (Solder type: 6, 10, and 12 pos.) Contact resistance 100m ohms min. (Through hole type: 6 and 12 pos.)	1000 cycles
6.Temperature cycle	Insulation resistance 100 M ohms min.	(-55°C: 30 minutes → Room temperature: 10 to 15 minutes → +85°C: 30 minutes → Room temperature: 10 to 15 minutes) for 5 cycles
7.Humidity resistance	Insulation resistance 10M ohms min. (when humidity high) 100M ohms min. (when dry)	96 hours at temperature of 40ohmsC and humidity of 90% to 95%
8.Waterproof performance	No penetration inside.	While mated with corresponding or protective cap submerged at depth of 1m for half hour.
9.Dust protection		

■Material

Assembly	Component	Material	Finish	Remarks
Plug	Insulator	PPS	Black	UL94V-0
		PBT	Black	UL94V-0
		Polyacetal	Natural	—
	Gasket	Silicone rubber, chloroprene rubber	Red/Black	—
	Contacts	Brass, phosphor bronze	Gold plated	—
	Spring	Stainless steel	—	—
Receptacles	Insulator	PPS	Black	UL94V-0
	Gasket	Chloroprene rubber	Black	—
	Contacts	Brass, phosphor bronze	Gold plated	—
	Hexagonal nut	Zinc alloy	Chromate	—
	Washer	Phosphor bronze	Nickel plated	—
Crimp contact (male/female)	Contacts	Phosphor bronze	Selective gold plated	—

■Ordering information

HR 30 - 6 P A - 6 S C

① ② ③ ④ ⑤ ⑥ ⑦

① Series name : HR30	⑤ Number of Contacts : 3, 6, 10 and 12
② Shell size : Outside diameter/plug mating side	⑥ Contact type S : Female contact P : Male contact
③ Connector type : P : Plug R : Receptacle J : Jack	⑦ Contact wiring type Blank : Solder C : Crimping D : Through hole
④ Variation Blank : Standard A : Fine wire	

Plugs

Solder Type

HR30-6P-6S (Shown)

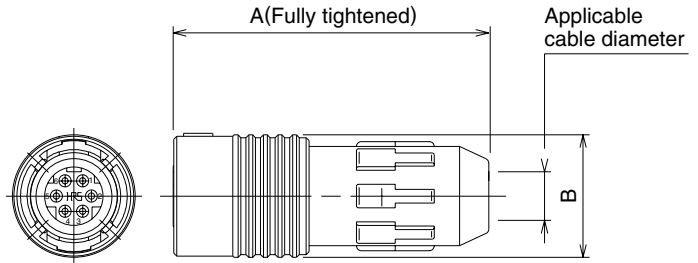

Part Number	CL No.	A	B	Solder pot inner diameter	Applicable cable diameter range	Weight
HR30-6P-3S	130-0004-1	29.8	12.6	1.1 mm	4.2 to 5	4g
HR30-6P-6S	130-0010-4	30.3		0.8 mm		
HR30-6P-6P	130-0009-5	29.8		1.1 mm	3.5 to 4.3	
HR30-6PA-3S	130-0021-0	30.3		0.8 mm		
HR30-6PA-6S	130-0019-9	39.8	15.5	0.6 mm	6.2 to 7	6.7g
HR30-6PA-6P	130-0020-8	39.8				
HR30-7P-12S	130-0027-7	39.8				
HR30-8P-12P	130-0026-4	39.8	15.5	0.6 mm	6.2 to 7	6.7g

Crimp Type

HR30-7P-12SC (Shown)



Shown with terminated and installed contacts.

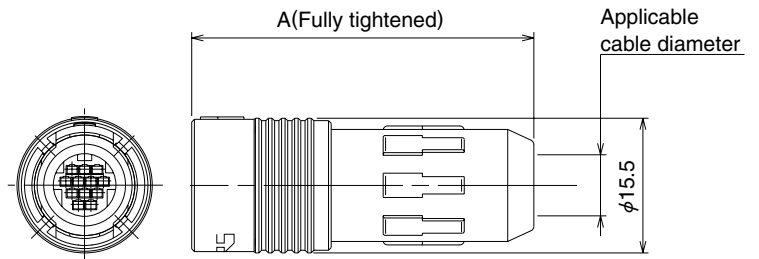

Part Number	CL No.	A	Crimp contact	Applicable cable diameter range	Weight
HR30-7P-10SC	130-0013-2	39.8	HR30-SC-211	6.2 to 7	6g
HR30-7P-12SC	130-0014-5		HR30-PC-211		
HR30-8P-12PC	130-0015-8		HR30-PC-211		

Note: Crimp contacts are not included. Please order applicable contacts separately.

■ Receptacles

● Solder Type

HR30-6R-6P (Shown)

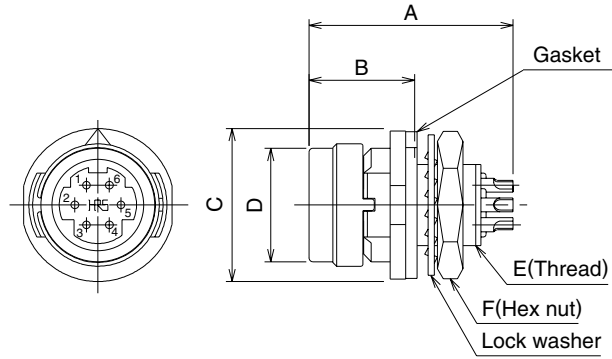
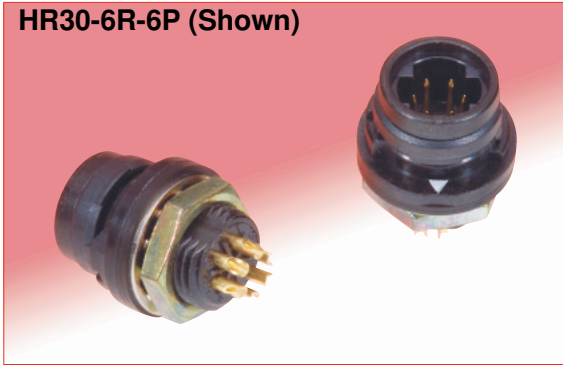

Part Number	CL No.	A	B	C	D	E	F	Solder pot inner diameter	Weight
HR30-6R-3P	130-1003-4	16	8.3	12	8.9	M8×0.75	10	1.1mm	2g
HR30-6R-6P	130-1009-0							0.8mm	
HR30-6R-6S	130-1008-8	18.4	9.3	15	11.5	M11×1	13	0.6mm	3.4g
HR30-7R-12P	130-1016-6	18.6							
HR30-8R-12S	130-1018-1								

● Crimp Type

HR30-7R-12PC (Shown)



Shown with terminated and installed contacts.

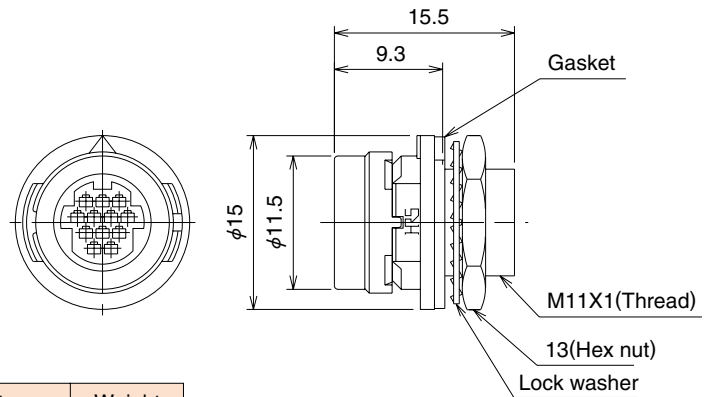

Part Number	CL No.	Crimp contact	Weight
HR30-7R-10PC	130-1012-5	HR30-PC-211	3g
HR30-7R-12PC	130-1013-8		
HR30-8R-12SC	130-1014-0	HR30-SC-211	

● Through hole Type

HR30-8R-12SD (Shown)

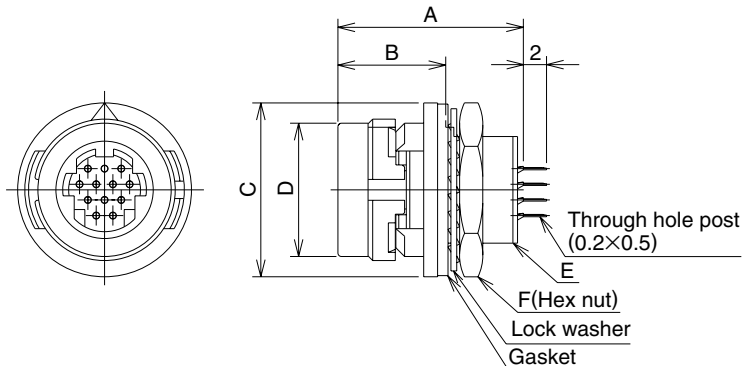

Part Number	CL No.	A	B	C	D	E	F	Weight
HR30-6R-6PD	130-1020-3	14.9	8.3	12	8.9	M8×0.75	10	2g
HR30-6R-6SD	130-1021-6	15.2						
HR30-7R-12PD	130-1017-9	16	9.3	15	11.5	M11×1	13	3.4g
HR30-8R-12SD	130-1019-4							

■Jacks

●Solder Type

HR30-6J-6P (Shown)

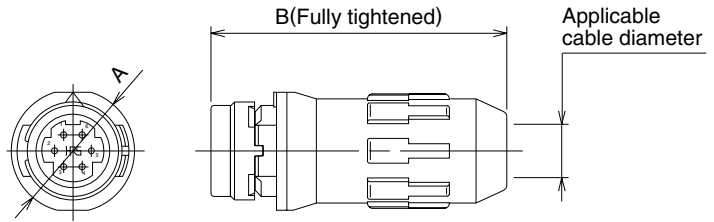

Part Number	CL No.	A	B	Applicable cable diameter range	Solder pot inner diameter	Weight
HR30-6J-6P	130-2009-6	12	28.9	4.2 to 5	0.8 mm	3g
HR30-6JA-6P	130-2018-7			3.5 to 4.3		
HR30-7J-12P	130-2020-9	15	37.3	6.2 to 7	0.6 mm	5.7g
HR30-8J-12S	130-2019-0					5.9g

●Crimp Type

HR30-7J-12PC (Shown)



Shown with terminated and installed contacts.

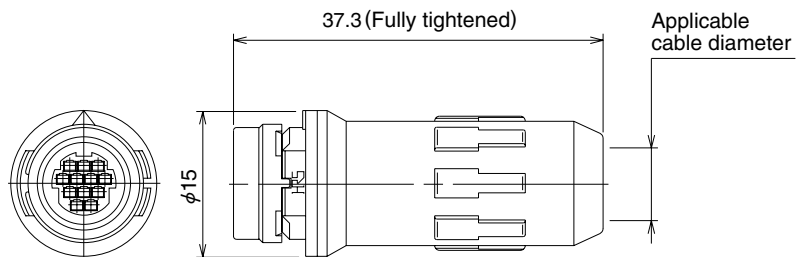

Part Number	CL No.	Crimp contact	Applicable cable diameter range	Weight
HR30-7J-10PC	130-2015-9	HR30-PC-211	6.2 to 7	5g
HR30-7J-12PC	130-2017-4			
HR30-8J-12SC	130-2016-1	HR30-SC-211		

Note: Crimp contacts are not included. Please order applicable contacts separately.

■ Caps

● For Plugs

HR30-6P-C

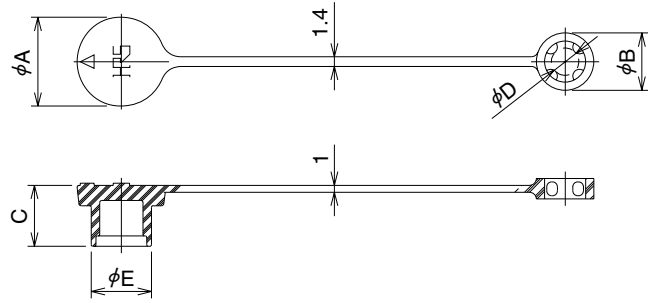

Part Number	CL No.	Applicable connector	A	B	C	D	E	Weight
HR30-6P-C	130-3000-7	HR30-6P-3S	13	8.4	8.9	4	8.8	1g
		HR30-6P-6S						
		HR30-6P-6P						
		HR30-6PA-3S						
		HR30-6PA-6S						
		HR30-6PA-6P						
HR30-7P-C	130-3004-8	HR30-7P-10SC	16	10.4	10.5	6	11.4	2g
		HR30-7P-12S						
		HR30-7P-12SC						
HR30-8P-C	130-3003-5	HR30-8P-12P	16	10.4	10.5	6	11.4	2g
		HR30-8P-12PC						

● For Receptacle

HR30-6R-C

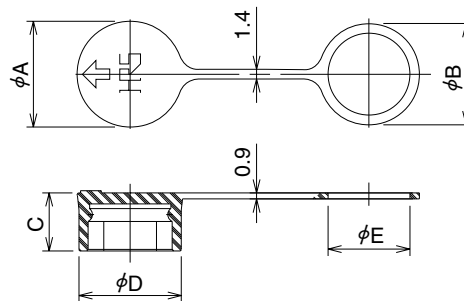
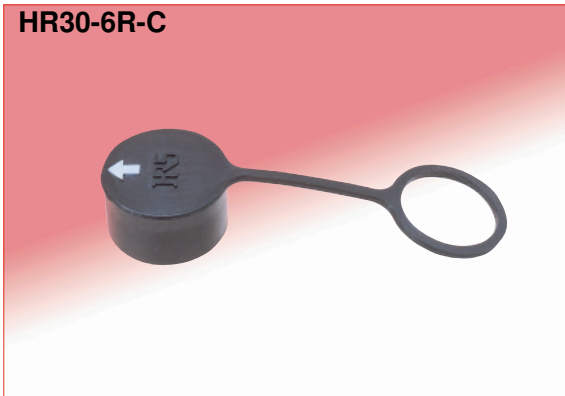

Part Number	CL No.	Applicable connector	A	B	C	D	E	Weight
HR30-6R-C	130-3001-0	HR30-6R-3P	12.6	11.8	7.5	12.1	9.1	1g
		HR30-6R-6P						
		HR30-6R-6PD						
		HR30-6R-6S						
		HR30-6R-6SD						
HR30-7R-C	130-3002-2	HR30-7R-10PC	15.5	14.8	8.5	15	12.1	
		HR30-7R-12P						
		HR30-7R-12PC						
		HR30-7R-12PD						
		HR30-8R-12S						
		HR30-8R-12SC						
HR30-8R-12SD								

Note : When using these caps, do not use the gasket that is normally supplied with the receptacle. The "B" diameter end of the receptacle cap will serve as the gasket.

■ Crimp Contacts

Male contact

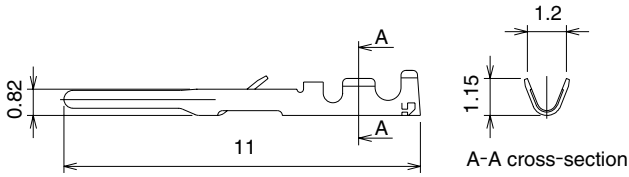

Female contact

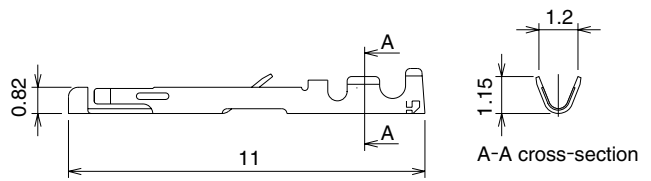

Part Number	CL No.	Packaging type	Weight
HR30-PC-111	130-0022-3	100pcs/bag	0.03g/1per pin
HR30-PC-211	130-0016-0	10,000pcs/reel	0.03g/1per pin

Part Number	CL No.	Packaging type	Weight
HR30-SC-111	130-0023-6	100pcs/bag	0.03g/1 pin
HR30-SC-211	130-0017-3	10,000pcs/reel	0.03g/1 pin

Note : Use wire size AWG 26 to 30 with a jacket diameter of 1 mm max.

◆ Connecting Combinations

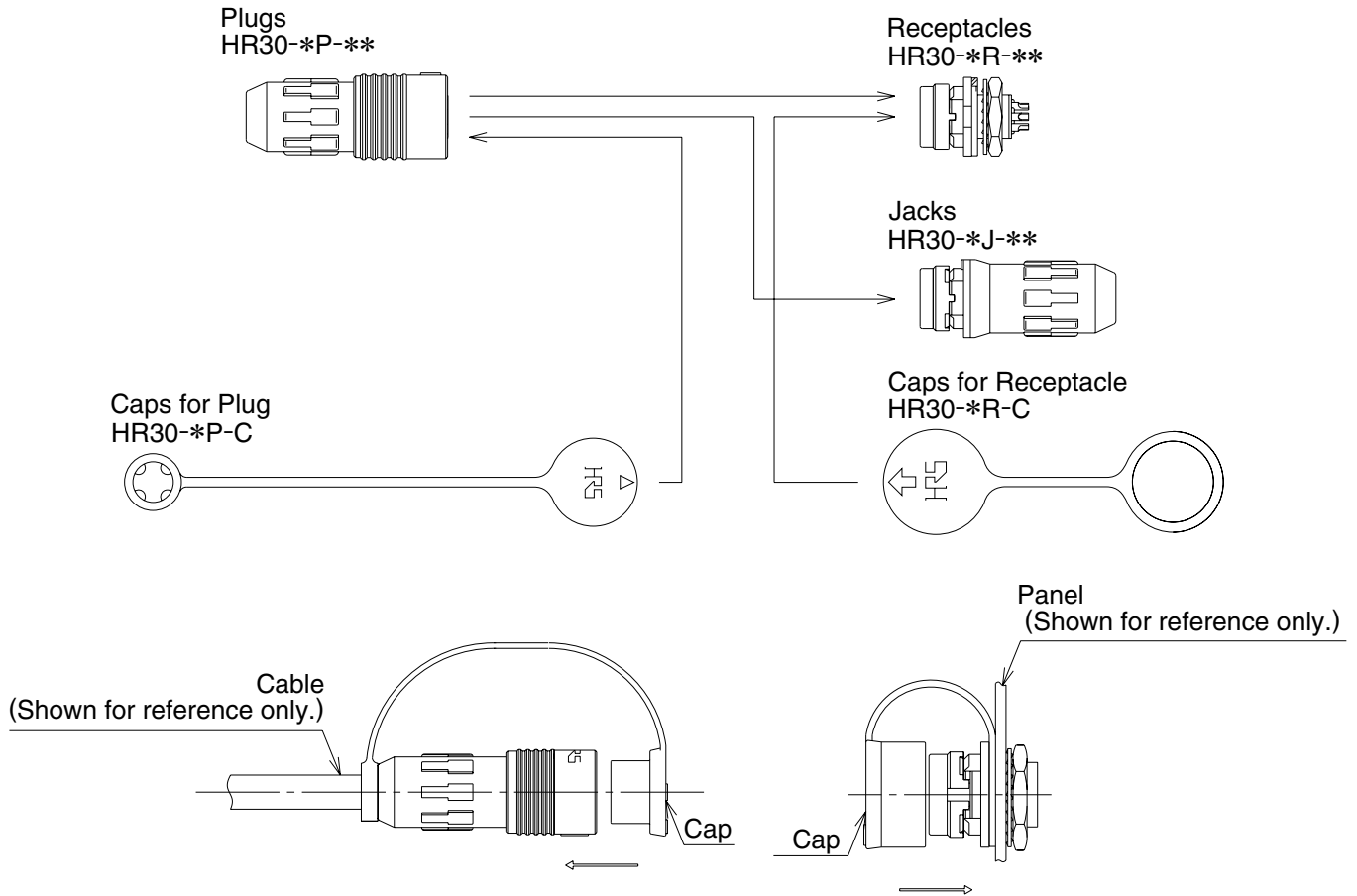

Note 1 : When selecting connectors, take into account the shell size, contact count and gender of the contacts.

Note 2 : When using the protective caps for the receptacles, do not use the gaskets normally supplied with the receptacle. Protective caps must be fully inserted to assure specified IP67 water and dust protection.

◆Applicable Fixtures

●Solder termination fixture

Part Number	CL No.	Applicable Connectors
HR30-6P-3S-T01	150-0220-1	HR30-6P-3S HR30-6PA-3S
HR30-6P-6S-T01	150-0214-9	HR30-6P-6S HR30-6PA-6S
HR30-6P-6P-T01	150-0221-4	HR30-6P-6P HR30-6PA-6P
HR30-7P-10SC-T01	150-0228-3	HR30-7P-10SC
HR30-7P-12SC-T01	150-0223-0	HR30-7P-12S HR30-7P-12SC
HR30-8P-12PC-T01	150-0227-0	HR30-8P-12P HR30-8P-12PC
HR30-6R-3P-T01	150-0225-5	HR30-6R-3P
HR30-6R-6P-T01	150-0218-0	HR30-6R-6P HR30-6J-6P HR30-6JA-6P
HR30-6R-6S-T01	150-0222-7	HR30-6R-6S
HR30-7J-10PC-T01	150-0231-8	HR30-7J-10PC
HR30-7J-12PC-T01	150-0230-5	HR30-7J-12PC
HR30-8J-12SC-T01	150-0226-8	HR30-8J-12SC

Note : The back shell tightening collar is used to tighten the back shell to the specified torque.
Refer to assembly procedures.

●Tightening collar for back shell

Part Number	CL No.	Applicable Connectors
HR30-6P-T02	150-0216-4	3 and 6 pos.
HR30-8P-T02	150-0224-2	10 and 12 pos.

Note: The back shell tightening collar is used to tighten the back shell to specified torque.
Refer to assembly procedures.



■Applicable Tools

Type	Description	Part Number	CL No.	Applicable contact	Applicable wire
Manual	Manual crimping tool	HT-102/HR30-1	150-0229-6	HR30-SC-111	AWG#26~#30
				HR30-PC-111	
Automatic	Automatic crimping machine	CM-105	901-0005-4	—	—
	Applicator	AP105-HR30-1	901-2015-9	HR30-SC-211 HR30-PC-211	AWG#26~#30
Extraction tool		HR30-TP	150-0219-2	HR30-SC-111	—
				HR30-SC-211	—
				HR30-PC-111	—
				HR30-PC-211	—

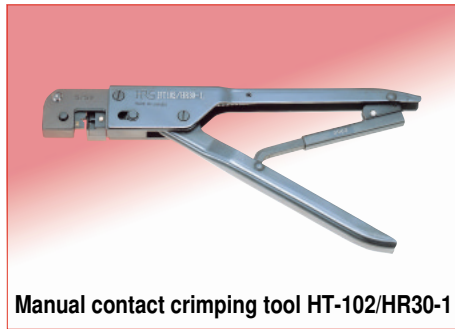

Manual contact crimping tool HT-102/HR30-1



Automatic contact crimping machine CM-105



Contact extraction tool HR30-TP

◆Receptacle, Board Mounting Through Hole Pattern

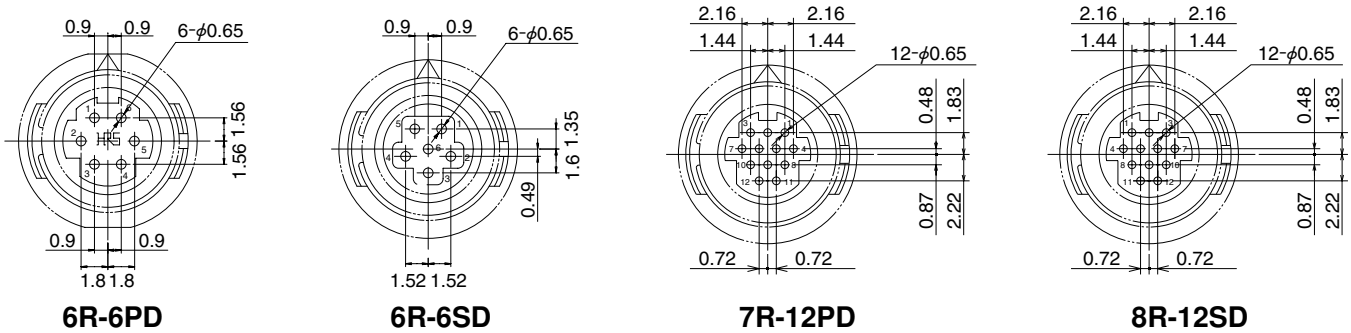

- Notes
- 1.The receptacle through hole configuration depicts a view from the mating side of the connector.
 - 2.The recommended board maximum thickness :1.2 mm.
 - 3.Tolerance of +0.03 mm is recommended for the plated through hole location.
Tolerance of +0.02 mm is recommended for the plated through hole diameter.

◆Contact Position Arrangement

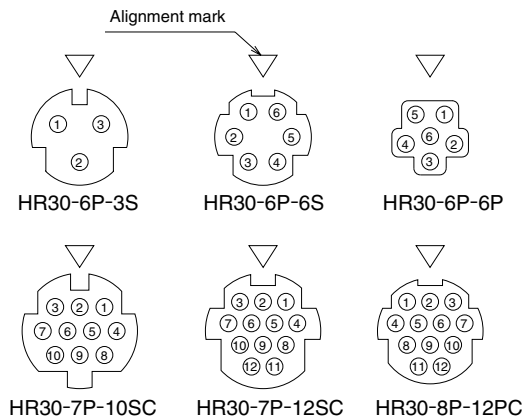

◆Panel Cutout

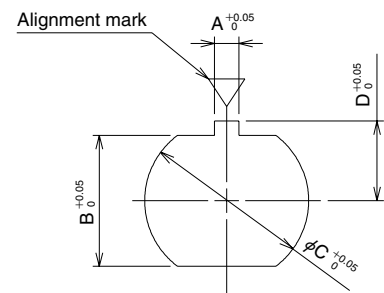

	A	B	C	D	Panel Thickness
3,6 pos	1.25	6.45	8.05	3.95	0.7~2
10,12 pos	1.35	9.25	11.05	5.45	0.7~3

- Notes
- 1.The contact configuration depicts a view from the wiring side.
 2. Mounting to the panel is accomplished by tightening the hexagonal nut from the rear side of the panel.

◆ Assembly Procedures

Plug Assembly Sequence

1

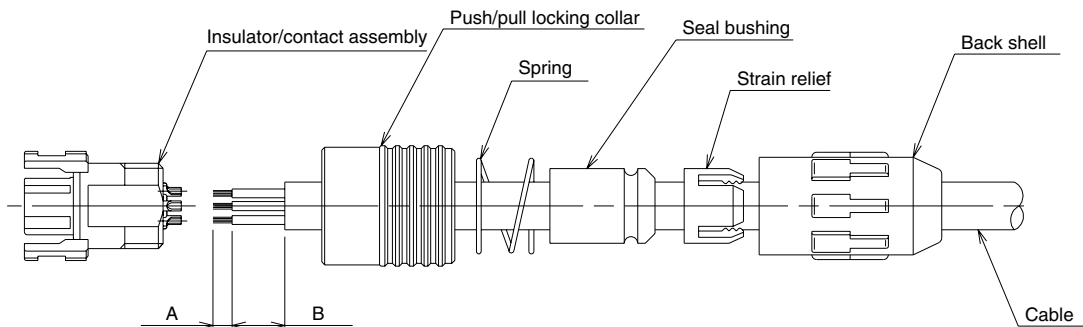

	A	B
Solder type : 3 and 6 pos.	2 mm	5.5 mm max.
Solder type : 12 pos.	2 mm	10 mm max.
Crimp type : 10 and 12 pos.	2 ⁰ / _{0.5} mm	15 to 20 mm

Thread the back shell, strain relief, seal bushing, spring and push/pull locking collar over the cable as shown above.

2

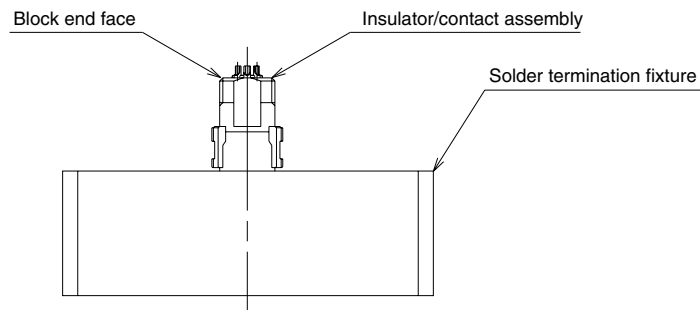

Solder type

1. Pre-solder the exposed cable conductors (dia. A). The diameter of the pre-soldered conductors should not exceed 0.7 mm for 6 contact plug and 1.0 mm for 3 contact plug.
2. Insert the insulator body over the applicable solder termination fixture.
3. Insert the pre-soldered conductors in the contact soldering pot and solder them in place.
Soldering iron temperature should be $280 \pm 10^\circ\text{C}$ applied for 3-4 second.

Crimp type

1. Crimp the applicable contact to the stripped conductor. Use correct crimp tools. Verify the dimensions and crimp configuration.
2. Insert the contact into the appropriate opening in the insulator body.
3. Verify fully seated position by applying a slight pull force on the conductor. The contact should remain in place.
Re-insert if not seated.

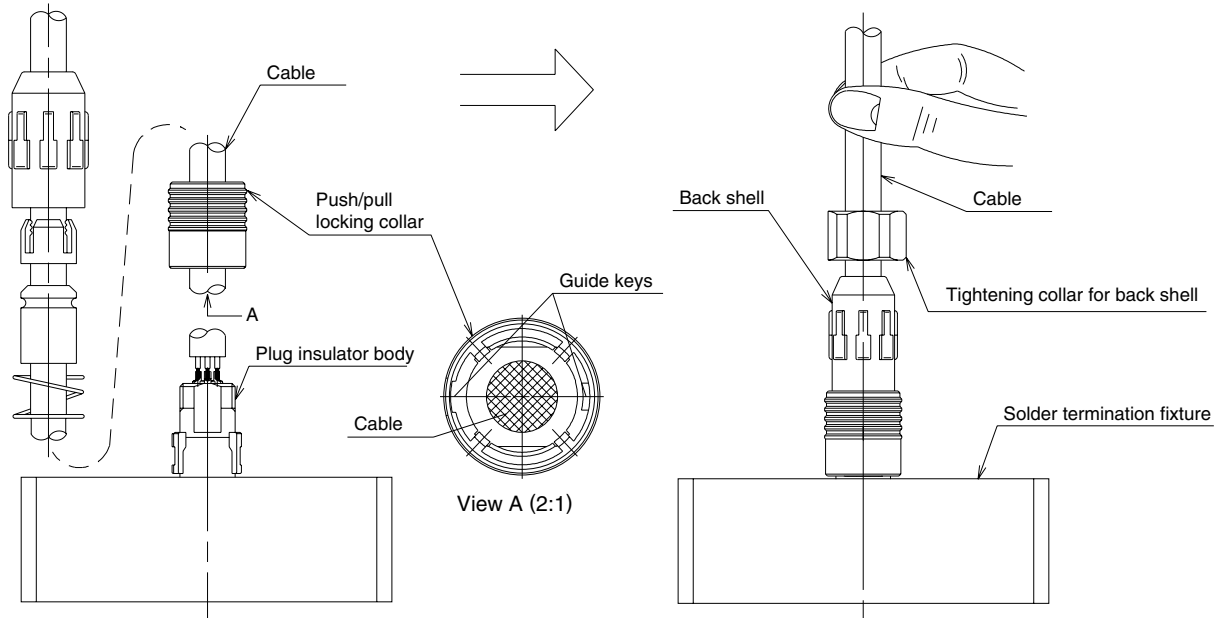

3

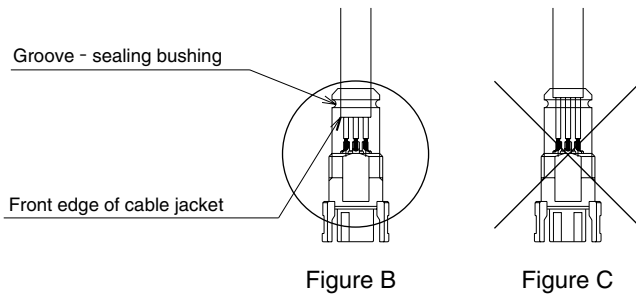

Connector	Back shell tightening collar size	Torque
3 and 6 Pos.	16 mm	0.5N·m
10 and 12 Pos.	18 mm	0.5N·m

1. To prevent accidental loosening of the back shell it is recommended that a small amount of primer (Loctite® 7649) and adhesive (Loctite® 271) be applied to the threads of the insulator body before proceeding.
2. Keeping the terminated insulator body on the fixture, re-assemble the plug in order shown.
4. Using the correct back-tightening collar tighten the back shell to the specified torque.
When tightening the collar make sure that the cable will NOT turn.
5. Remove the assembly from the fixture.

Note: Loctite is a registered trademark of the Henkel Loctite Corporation.

◆ General usage notes

1. Mating	2. Un-mating
<p>When mounting, smooth mating will be achieved by holding plug in any are "A" and aligning the arrow of the plug with that of the receptacle ,then pushing the plug straight in.</p>	<p>When removing the plug from its connected condition, hold the plug by push/pull locking collar (area "B") and pull straight off.</p>

◆ Precautions

1. Do NOT apply force in excess of 30N in the directions shown below.

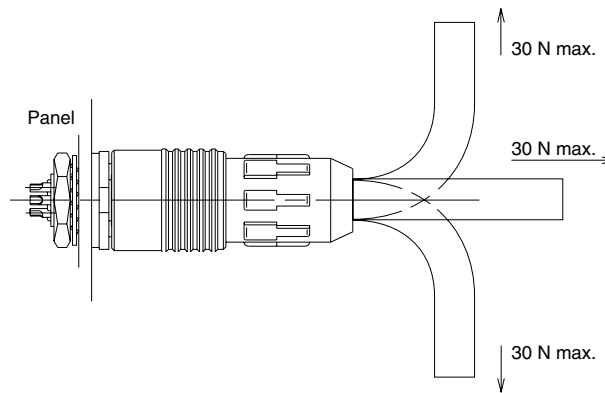

2. To maintain the water/dust protection performance and the cable clamp force, use a cable that is within the range of applicable cable diameter.
3. Consult HRS representative when using different cables.



HIROSE ELECTRIC CO.,LTD.

5-23,OSAKI 5-CHOME,SHINAGAWA-KU,TOKYO 141-8587,JAPAN
 PHONE: 81-3-3491-9741, FAX: 81-3-3493-2933
<http://www.hirose.com>
<http://www.hirose-connectors.com>