



Chipsmall Limited consists of a professional team with an average of over 10 year of expertise in the distribution of electronic components. Based in Hongkong, we have already established firm and mutual-benefit business relationships with customers from,Europe,America and south Asia,supplying obsolete and hard-to-find components to meet their specific needs.

With the principle of “Quality Parts,Customers Priority,Honest Operation,and Considerate Service”,our business mainly focus on the distribution of electronic components. Line cards we deal with include Microchip,ALPS,ROHM,Xilinx,Pulse,ON,Everlight and Freescale. Main products comprise IC,Modules,Potentiometer,IC Socket,Relay,Connector.Our parts cover such applications as commercial,industrial, and automotives areas.

We are looking forward to setting up business relationship with you and hope to provide you with the best service and solution. Let us make a better world for our industry!



## Contact us

Tel: +86-755-8981 8866 Fax: +86-755-8427 6832

Email & Skype: info@chipsmall.com Web: www.chipsmall.com

Address: A1208, Overseas Decoration Building, #122 Zhenhua RD., Futian, Shenzhen, China



**100A, 55V, 0.008 Ohm, N-Channel, Power MOSFETs**

These are N-Channel enhancement mode silicon gate power field effect transistors. They are advanced power MOSFETs designed, tested, and guaranteed to withstand a specified level of energy in the breakdown avalanche mode of operation. All of these power MOSFETs are designed for applications such as switching regulators, switching converters, motor drivers, relay drivers, and drivers for high power bipolar switching transistors requiring high speed and low gate drive power. These types can be operated directly from integrated circuits.

**NOTE: Calculated continuous current based on maximum allowable junction temperature. Package limited to 75A continuous, see Figure 9.**

**Ordering Information**

PART NUMBER	PACKAGE	BRAND
HRF3205	TO-220AB	HRF3205
HRF3205S	TO-263AB	HRF3205S

NOTE: When ordering, use the entire part number. Add the suffix T to obtain the TO-263AB variant in tape and reel, e.g., HRF3205ST.

**Features**

- 100A, 55V (See Note)
- Low On-Resistance,  $r_{DS(ON)} = 0.008\Omega$
- Temperature Compensating PSPICE® Model
- Thermal Impedance SPICE Model
- UIS Rating Curve
- Related Literature
  - TB334, "Guidelines for Soldering Surface Mount Components to PC Boards"

**Symbol**

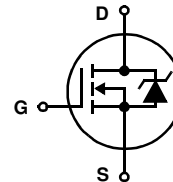

**Packaging**

**JEDEC TO-220AB**



**JEDEC TO-263AB**

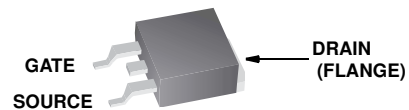

# HRF3205, HRF3205S

## Absolute Maximum Ratings $T_C = 25^\circ\text{C}$ , Unless Otherwise Specified

Drain to Source Voltage (Note 1)	$V_{DSS}$	55	V
Drain to Gate Voltage ( $R_{GS} = 20k\Omega$ ) (Note 1)	$V_{DGR}$	55	V
Gate to Source Voltage	$V_{GS}$	$\pm 20V$	V
Drain Current			
Continuous	$I_D$	100	A
Pulsed Drain Current (Note 2)	$I_{DM}$	390	A
Pulsed Avalanche Rating	$E_{AS}$	Figure 10	
Power Dissipation	$P_D$	175	W
Derate Above $25^\circ\text{C}$		1.17	W/ $^\circ\text{C}$
Operating and Storage Temperature	$T_J, T_{STG}$	-55 to 175	$^\circ\text{C}$
Maximum Temperature for Soldering			
Leads at 0.063in (1.6mm) from Case for 10s	$T_L$	300	$^\circ\text{C}$
Package Body for 10s, See Techbrief 334	$T_{pkg}$	260	$^\circ\text{C}$

**CAUTION:** Stresses above those listed in "Absolute Maximum Ratings" may cause permanent damage to the device. This is a stress only rating and operation of the device at these or any other conditions above those indicated in the operational sections of this specification is not implied.

### NOTE:

- $T_J = 25^\circ\text{C}$  to  $150^\circ\text{C}$ .

## Electrical Specifications $T_C = 25^\circ\text{C}$ , Unless Otherwise Specified

PARAMETER	SYMBOL	TEST CONDITIONS	MIN	TYP	MAX	UNITS
Drain to Source Breakdown Voltage	$BV_{DSS}$	$I_D = 250\mu\text{A}, V_{GS} = 0V$	55	-	-	V
Gate to Source Threshold Voltage	$V_{GS(TH)}$	$V_{GS} = V_{DS}, I_D = 250\mu\text{A}$	2	-	4	V
Zero Gate Voltage Drain Current	$I_{DSS}$	$V_{DS} = 55V, V_{GS} = 0V$	-	-	25	$\mu\text{A}$
		$V_{DS} = 44V, V_{GS} = 0V, T_C = 150^\circ\text{C}$	-	-	250	$\mu\text{A}$
Gate to Source Leakage Current	$I_{GSS}$	$V_{GS} = \pm 20V$	-	-	100	nA
Breakdown Voltage Temperature Coefficient	$\frac{\Delta V_{(BR)DSS}}{\Delta T_J}$	Reference to $25^\circ\text{C}, I_D = 250\mu\text{A}$	-	0.057	-	V
Drain to Source On Resistance	$r_{DS(ON)}$	$I_D = 59A, V_{GS} = 10V$ (Figure 4)	-	0.0065	0.008	$\Omega$
Turn-On Delay Time	$t_{d(ON)}$	$V_{DD} = 28V, I_D \equiv 59A,$ $R_L = 0.47\Omega, V_{GS} = 10V,$ $R_{GS} = 2.5\Omega$	-	14	-	ns
Rise Time	$t_r$		-	100	-	ns
Turn-Off Delay Time	$t_{d(OFF)}$		-	43	-	ns
Fall Time	$t_f$		-	70	-	ns
Total Gate Charge	$Q_g$	$V_{DD} = 44V, I_D \equiv 59A,$ $V_{GS} = 10V, I_{g(REF)} = 3mA$ (Figure 6)	-	-	170	nC
Gate to Source Charge	$Q_{gs}$		-	-	32	nC
Gate to Drain "Miller" Charge	$Q_{gd}$		-	-	74	nC
Input Capacitance	$C_{ISS}$	$V_{DS} = 25V, V_{GS} = 0V,$ $f = 1MHz$ (Figure 5)	-	4000	-	pF
Output Capacitance	$C_{OSS}$		-	1300	-	pF
Reverse Transfer Capacitance	$C_{RSS}$		-	480	-	pF
Internal Source Inductance	$L_S$	Measured From the Contact Screw on Tab to Center of Die	-	7.5	-	nH
		Measured From the Drain Lead, 6mm (0.25in) From Package to Center of Die				
Internal Drain Inductance	$L_D$	Measured From the Source Lead, 6mm (0.25in) From Header to Source Bonding Pad	-	4.5	-	nH
Thermal Resistance Junction to Case	$R_{\theta JC}$		-	-	0.85	$^\circ\text{C/W}$
Thermal Resistance Junction to Ambient	$R_{\theta JA}$	TO-220	-	-	62	$^\circ\text{C/W}$
		TO-263 (PCB Mount, Steady State)	-	-	40	$^\circ\text{C/W}$

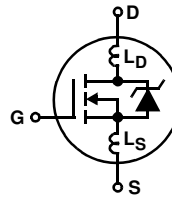

Source to Drain Diode Specifications

PARAMETER	SYMBOL	TEST CONDITIONS	MIN	TYP	MAX	UNITS
Continuous Source to Drain Current	$I_{SD}$	MOSFET Symbol Showing The Integral Reverse P-N Junction Diode	-	-	100 (Note 1)	A
Pulsed Source to Drain Current (Note 2)	$I_{SDM}$		-	-	390	A
Source to Drain Diode Voltage	$V_{SD}$	$I_{SD} = 59A$ (Note 4)	-	-	1.3	V
Reverse Recovery Time	$t_{rr}$	$I_{SD} = 59A, dI_{SD}/dt = 100A/\mu s$ (Note 4)	-	110	170	ns
Reverse Recovered Charge	$Q_{RR}$	$I_{SD} = 59A, dI_{SD}/dt = 100A/\mu s$ (Note 4)	-	450	680	nC

NOTE:

2. Repetitive rating; pulse width limited by maximum junction temperature (See Figure 11)

Typical Performance Curves

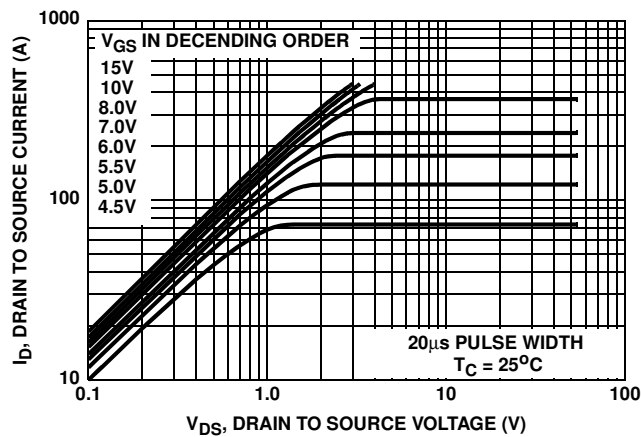

FIGURE 1. OUTPUT CHARACTERISTICS

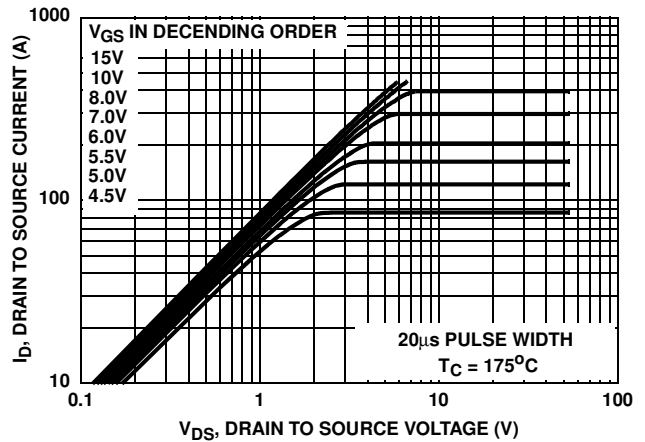

FIGURE 2. OUTPUT CHARACTERISTICS

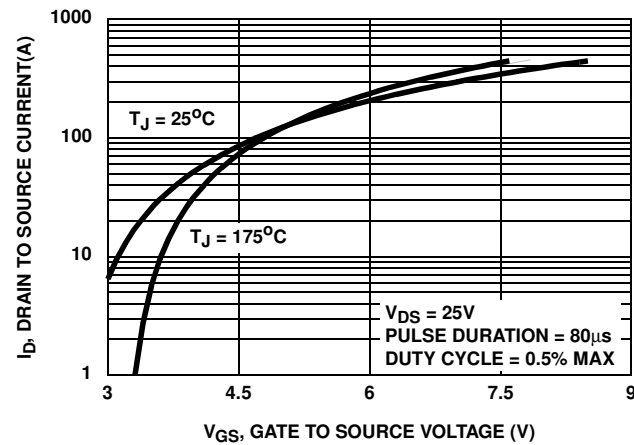

FIGURE 3. TRANSFER CHARACTERISTICS

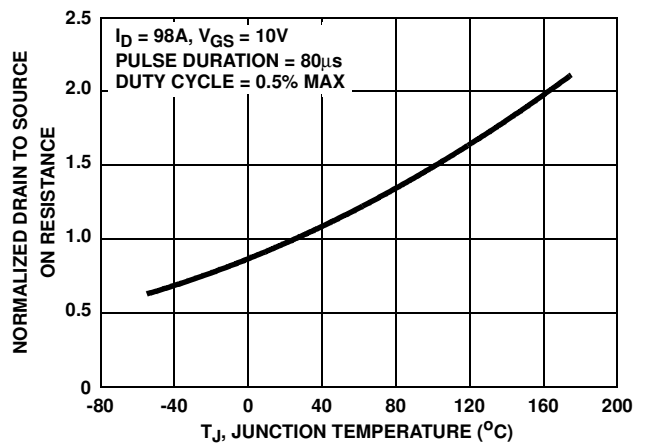

FIGURE 4. NORMALIZED DRAIN TO SOURCE ON RESISTANCE vs JUNCTION TEMPERATURE

Typical Performance Curves (Continued)

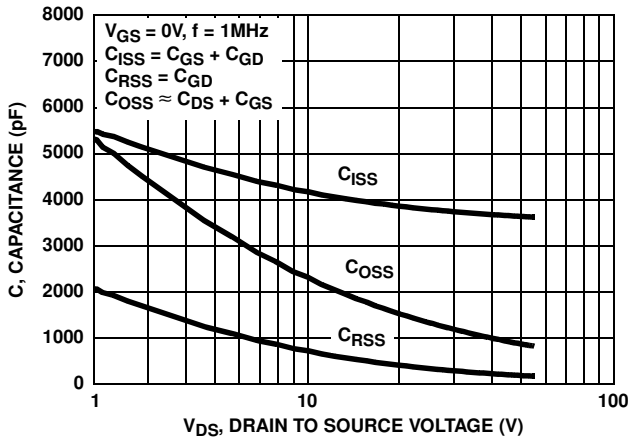

FIGURE 5. CAPACITANCE vs DRAIN TO SOURCE VOLTAGE

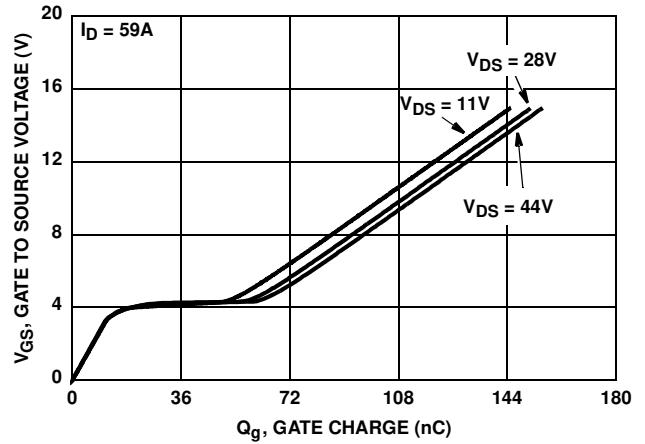

FIGURE 6. GATE CHARGE WAVEFORMS FOR CONSTANT GATE CURRENT

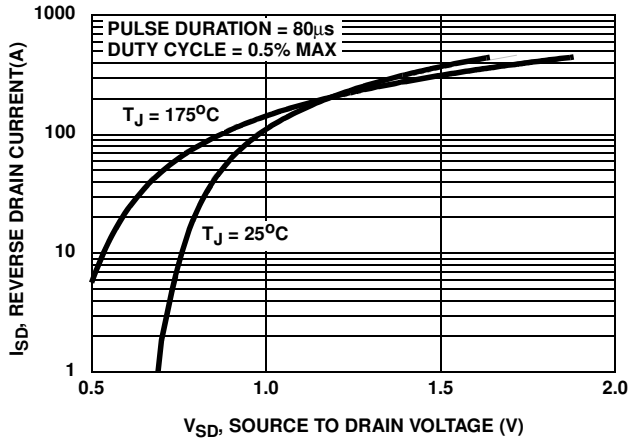

FIGURE 7. SOURCE TO DRAIN DIODE FORWARD VOLTAGE

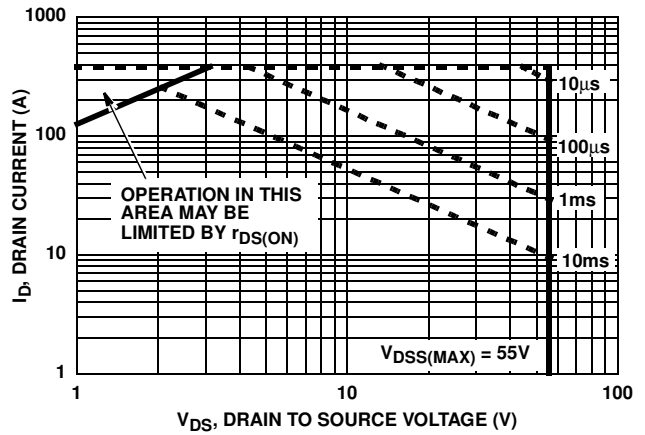

FIGURE 8. FORWARD BIAS SAFE OPERATING AREA

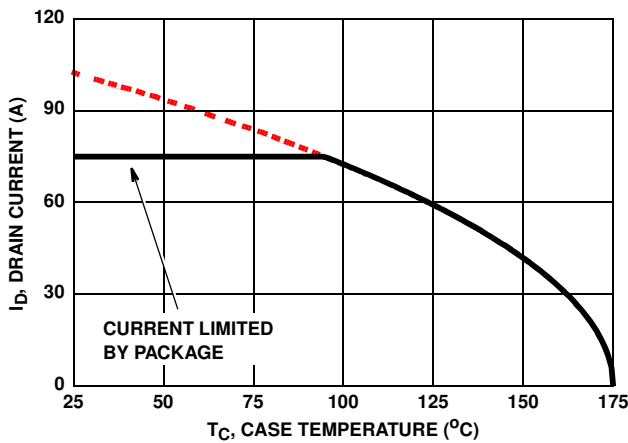

FIGURE 9. MAXIMUM CONTINUOUS DRAIN CURRENT vs CASE TEMPERATURE

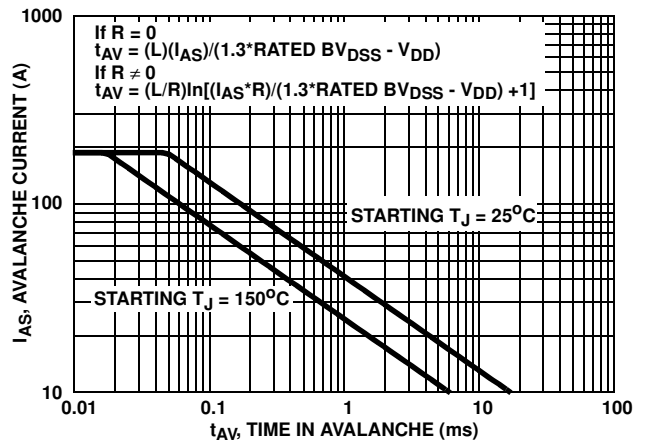

FIGURE 10. UNCLAMPED INDUCTIVE SWITCHING CAPABILITY

Typical Performance Curves (Continued)

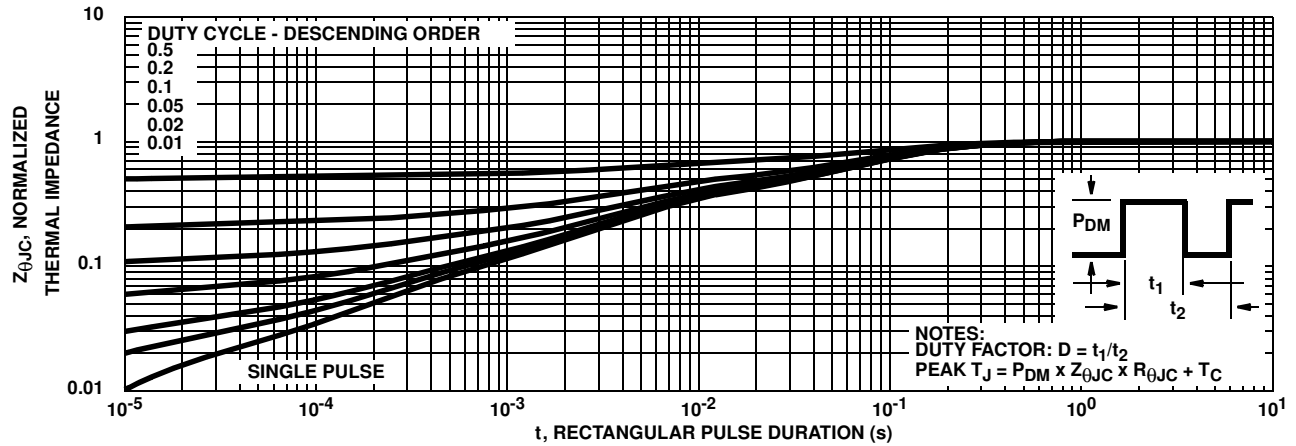

FIGURE 11. NORMALIZED MAXIMUM TRANSIENT THERMAL IMPEDANCE

Test Circuits and Waveforms

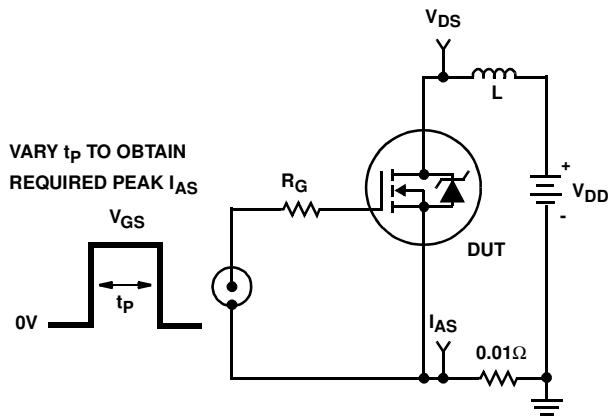

FIGURE 12. UNCLAMPED ENERGY TEST CIRCUIT

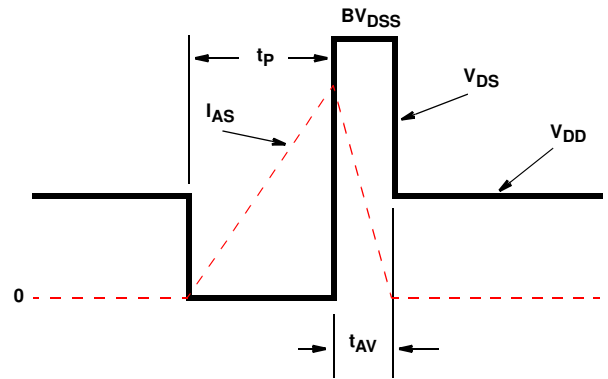

FIGURE 13. UNCLAMPED ENERGY WAVEFORMS

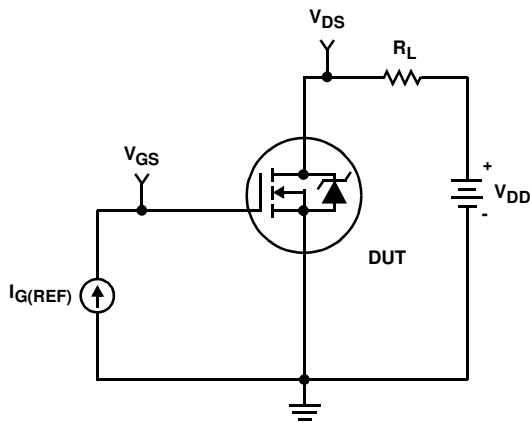

FIGURE 14. GATE CHARGE TEST CIRCUIT

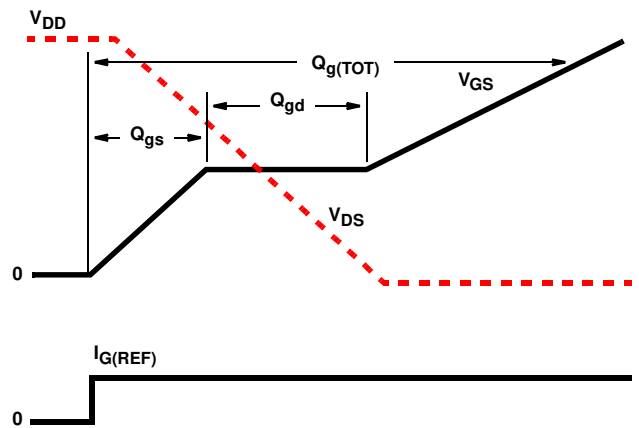

FIGURE 15. GATE CHARGE WAVEFORM

Test Circuits and Waveforms (Continued)

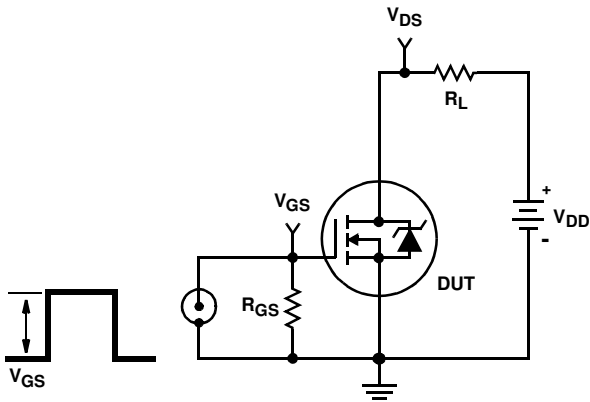

FIGURE 16. SWITCHING TIME TEST CIRCUIT

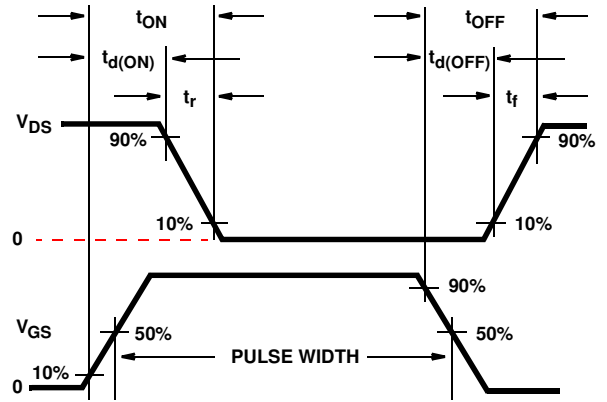

FIGURE 17. RESISTIVE SWITCHING WAVEFORMS

# HRF3205, HRF3205S

## PSPICE Electrical Model

SUBCKT HRF3205P3 2 1 3 ; rev 7/25/97

CA 12 8 4.9e-9  
 CB 15 14 4.9e-9  
 CIN 6 8 3.45e-9

DBODY 7 5 DBODYMOD  
 DBREAK 5 11 DBREAKMOD  
 DPLCAP 10 5 DPLCAPMOD

EBREAK 11 7 17 18 57  
 EDS 14 8 5 8 1  
 EGS 13 8 6 8 1  
 ESG 6 10 6 8 1  
 EVTHRES 6 21 19 8 1  
 EVTEMP 20 6 18 22 1

IT 8 17 1

LDRAIN 2 5 1e-9  
 LGATE 1 9 2.6e-9  
 LSOURCE 3 7 1.1e-9  
 K1 LGATE LSOURCE 0.0085

MMED 16 6 8 8 MMEDMOD  
 MSTRO 16 6 8 8 MSTROMOD  
 MWEAK 16 21 8 8 MWEAKMOD

RBREAK 17 18 RBREAKMOD 1  
 RDRAIN 50 16 RDRAINMOD 3.5e-4  
 RGATE 9 20 0.36  
 RLDRAIN 2 5 10  
 RLGATE 1 9 26  
 RLSOURCE 3 7 11  
 RSLC1 5 51 RSLCMOD 1e-6  
 RSLC2 5 50 1e3  
 RSOURCE 8 7 RSOURCEMOD 4.5e-3  
 RVTHRES 22 8 RVTHRESMOD 1  
 RVTEMP 18 19 RVTEMPMOD 1

S1A 6 12 13 8 S1AMOD  
 S1B 13 12 13 8 S1BMOD  
 S2A 6 15 14 13 S2AMOD  
 S2B 13 15 14 13 S2BMOD

VBAT 22 19 DC 1

ESLC 51 50 VALUE={(V(5,51)/ABS(V(5,51)))\*(PWR(V(5,51))/(1e-6\*550),3))}

.MODEL DBODYMOD D (IS = 4.25e-12 RS = 1.8e-3 TRS1 = 2.75e-3 TRS2 = 5e-6 CJO = 5.95e-9 TT = 4e-7 M = 0.55)  
 .MODEL DBREAKMOD D (RS = 0.0 6IKF = 30 TRS1 = -3e-3 TRS2 = 3e-6)  
 .MODEL DPLCAPMOD D (CJO = 4.45e-9 IS = 1e-3 ON = 1 M = 0.88 VJ = 1.45)  
 .MODEL MMEDMOD NMOS (VTO = 2.93 KP = 9.5 IS = 1e-30 N = 10 TOX = 1 L = 1u W = 1u RG = 1)  
 .MODEL MSTROMOD NMOS (VTO = 3.23 KP = 150 IS = 1e-30 N = 10 TOX = 1 L = 1u W = 1u)  
 .MODEL MWEAKMOD NMOS (VTO = 2.35 KP = 0.02 IS = 1e-30 N = 10 TOX = 1 L = 1u W = 1u RG = 10)  
 .MODEL RBREAKMOD RES (TC1 = 8e-4 TC2 = 4e-6)  
 .MODEL RDRAINMOD RES (TC1 = 8e-2 TC2 = 5e-6)  
 .MODEL RSLCMOD RES (TC1 = 1e-4 TC2 = 1.05e-6)  
 .MODEL RSOURCEMOD RES (TC1 = 1e-4 TC2 = 1.5e-5)  
 .MODEL RVTHRESMOD RES (TC1 = -2.3e-3 TC2 = -1.2e-5)  
 .MODEL RVTEMPMOD RES (TC1 = -2.2e-3 TC2 = -7e-6)

.MODEL S1AMOD VSWITCH (RON = 1e-5 ROFF = 0.1 VON = -9 VOFF = -4)  
 .MODEL S1BMOD VSWITCH (RON = 1e-5 ROFF = 0.1 VON = -4 VOFF = -9)  
 .MODEL S2AMOD VSWITCH (RON = 1e-5 ROFF = 0.1 VON = 0 VOFF = 2.5)  
 .MODEL S2BMOD VSWITCH (RON = 1e-5 ROFF = 0.1 VON = 2.5 VOFF = 0)

.ENDS

NOTE: For further discussion of the PSPICE model, consult **A New PSPICE Sub-Circuit for the Power MOSFET Featuring Global Temperature Options**; IEEE Power Electronics Specialist Conference Records, 1991, written by William J. Hepp and C. Frank Wheatley.

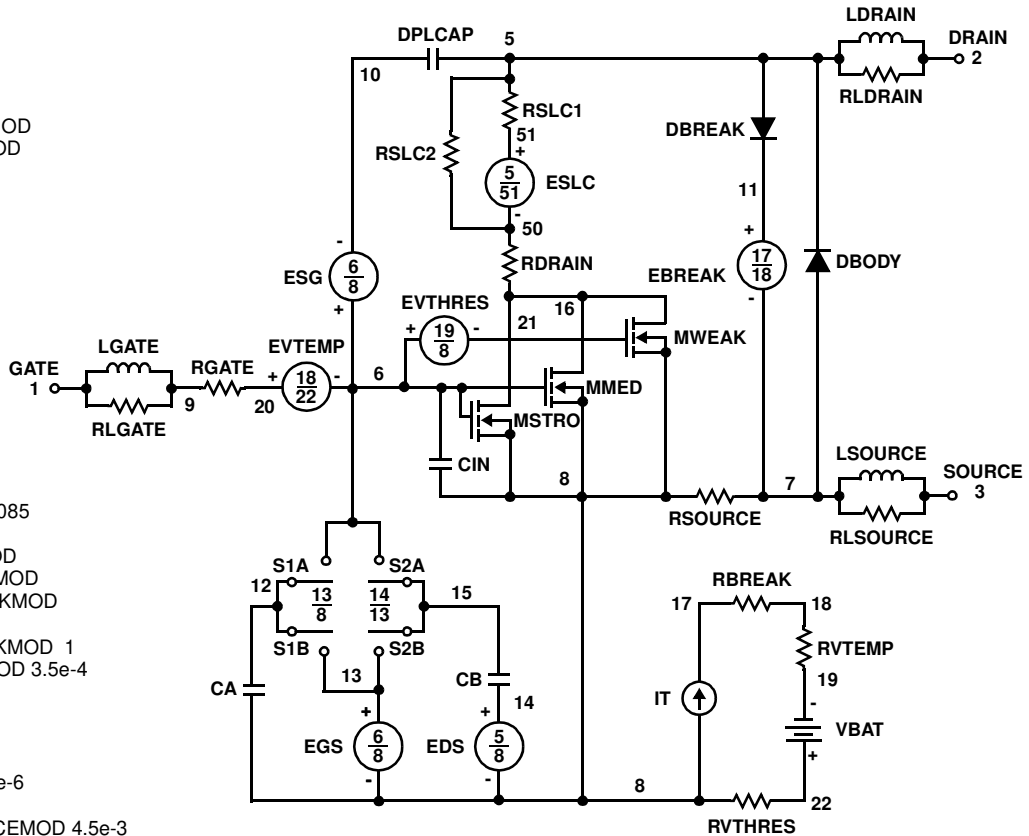

**SPICE Thermal Model**

REV 25 July 97

HRF3205

CTHERM1 7 6 2.53e-5  
 CHERM2 6 5 1.38e-3  
 CHERM3 5 4 7.00e-3  
 CHERM4 4 3 2.50e-2  
 CHERM5 3 2 1.33e-1  
 CHERM6 2 1 5.75e-1

RHERM1 7 6 7.78e-4  
 RHERM2 6 5 8.55e-3  
 RHERM3 5 4 3.00e-2  
 RHERM4 4 3 1.42e-1  
 RHERM5 3 2 2.65e-1  
 RHERM6 2 1 2.33e-1

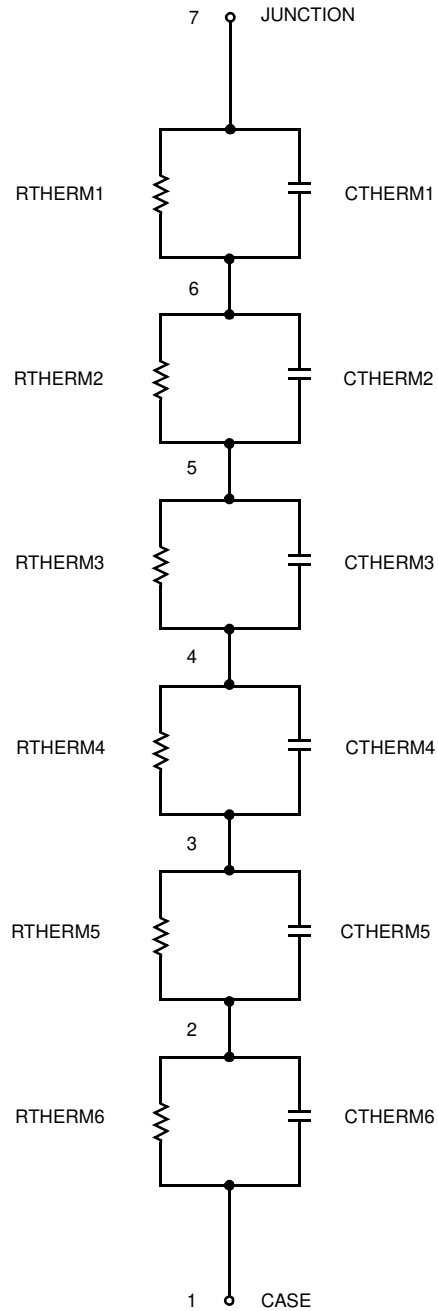

## TRADEMARKS

The following are registered and unregistered trademarks Fairchild Semiconductor owns or is authorized to use and is not intended to be an exhaustive list of all such trademarks.

ACE <sub>x</sub> <sup>™</sup>	FAST <sup>®</sup>	OPTOLOGIC <sup>™</sup>	SMART START <sup>™</sup>	VCX <sup>™</sup>
Bottomless <sup>™</sup>	FAST <sub>r</sub> <sup>™</sup>	OPTOPLANAR <sup>™</sup>	STAR*POWER <sup>™</sup>	
CoolFET <sup>™</sup>	FRFET <sup>™</sup>	PACMAN <sup>™</sup>	Stealth <sup>™</sup>	
CROSSVOLT <sup>™</sup>	GlobalOptoisolator <sup>™</sup>	POP <sup>™</sup>	SuperSOT <sup>™</sup> -3	
DenseTrench <sup>™</sup>	GTO <sup>™</sup>	Power247 <sup>™</sup>	SuperSOT <sup>™</sup> -6	
DOMET <sup>™</sup>	HiSeC <sup>™</sup>	PowerTrench <sup>®</sup>	SuperSOT <sup>™</sup> -8	
EcoSPARK <sup>™</sup>	ISOPLANAR <sup>™</sup>	QFET <sup>™</sup>	SyncFET <sup>™</sup>	
E <sup>2</sup> CMOS <sup>™</sup>	LittleFET <sup>™</sup>	QS <sup>™</sup>	TinyLogic <sup>™</sup>	
EnSigna <sup>™</sup>	MicroFET <sup>™</sup>	QT Optoelectronics <sup>™</sup>	TruTranslation <sup>™</sup>	
FACT <sup>™</sup>	MicroPak <sup>™</sup>	Quiet Series <sup>™</sup>	UHC <sup>™</sup>	
FACT Quiet Series <sup>™</sup>	MICROWIRE <sup>™</sup>	SILENT SWITCHER <sup>®</sup>	UltraFET <sup>®</sup>	

STAR\*POWER is used under license

## DISCLAIMER

FAIRCHILD SEMICONDUCTOR RESERVES THE RIGHT TO MAKE CHANGES WITHOUT FURTHER NOTICE TO ANY PRODUCTS HEREIN TO IMPROVE RELIABILITY, FUNCTION OR DESIGN. FAIRCHILD DOES NOT ASSUME ANY LIABILITY ARISING OUT OF THE APPLICATION OR USE OF ANY PRODUCT OR CIRCUIT DESCRIBED HEREIN; NEITHER DOES IT CONVEY ANY LICENSE UNDER ITS PATENT RIGHTS, NOR THE RIGHTS OF OTHERS.

## LIFE SUPPORT POLICY

FAIRCHILD'S PRODUCTS ARE NOT AUTHORIZED FOR USE AS CRITICAL COMPONENTS IN LIFE SUPPORT DEVICES OR SYSTEMS WITHOUT THE EXPRESS WRITTEN APPROVAL OF FAIRCHILD SEMICONDUCTOR CORPORATION.

As used herein:

1. Life support devices or systems are devices or systems which, (a) are intended for surgical implant into the body, or (b) support or sustain life, or (c) whose failure to perform when properly used in accordance with instructions for use provided in the labeling, can be reasonably expected to result in significant injury to the user.
2. A critical component is any component of a life support device or system whose failure to perform can be reasonably expected to cause the failure of the life support device or system, or to affect its safety or effectiveness.

## PRODUCT STATUS DEFINITIONS

### Definition of Terms

Datasheet Identification	Product Status	Definition
Advance Information	Formative or In Design	This datasheet contains the design specifications for product development. Specifications may change in any manner without notice.
Preliminary	First Production	This datasheet contains preliminary data, and supplementary data will be published at a later date. Fairchild Semiconductor reserves the right to make changes at any time without notice in order to improve design.
No Identification Needed	Full Production	This datasheet contains final specifications. Fairchild Semiconductor reserves the right to make changes at any time without notice in order to improve design.
Obsolete	Not In Production	This datasheet contains specifications on a product that has been discontinued by Fairchild semiconductor. The datasheet is printed for reference information only.