



Chipsmall Limited consists of a professional team with an average of over 10 year of expertise in the distribution of electronic components. Based in Hongkong, we have already established firm and mutual-benefit business relationships with customers from,Europe,America and south Asia,supplying obsolete and hard-to-find components to meet their specific needs.

With the principle of “Quality Parts,Customers Priority,Honest Operation,and Considerate Service”,our business mainly focus on the distribution of electronic components. Line cards we deal with include Microchip,ALPS,ROHM,Xilinx,Pulse,ON,Everlight and Freescale. Main products comprise IC,Modules,Potentiometer,IC Socket,Relay,Connector.Our parts cover such applications as commercial,industrial, and automotives areas.

We are looking forward to setting up business relationship with you and hope to provide you with the best service and solution. Let us make a better world for our industry!



Contact us

Tel: +86-755-8981 8866 Fax: +86-755-8427 6832

Email & Skype: info@chipsmall.com Web: www.chipsmall.com

Address: A1208, Overseas Decoration Building, #122 Zhenhua RD., Futian, Shenzhen, China



HSBP/HSIP - SERIES

BUL10413

REV. A

ASSEMBLY INSTRUCTIONS FOR HSBP/HSIP SIDE INNER PANELS

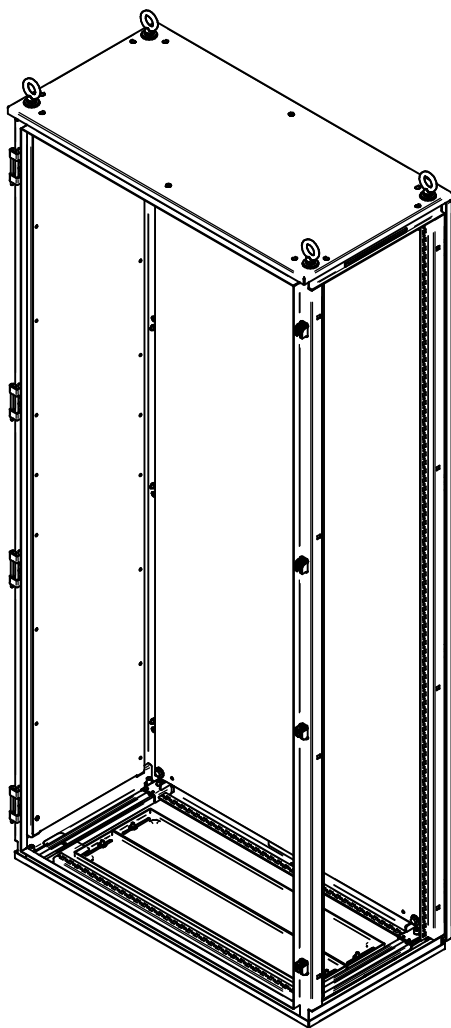

FIG 1. SIDE MTG BARRIER PANEL

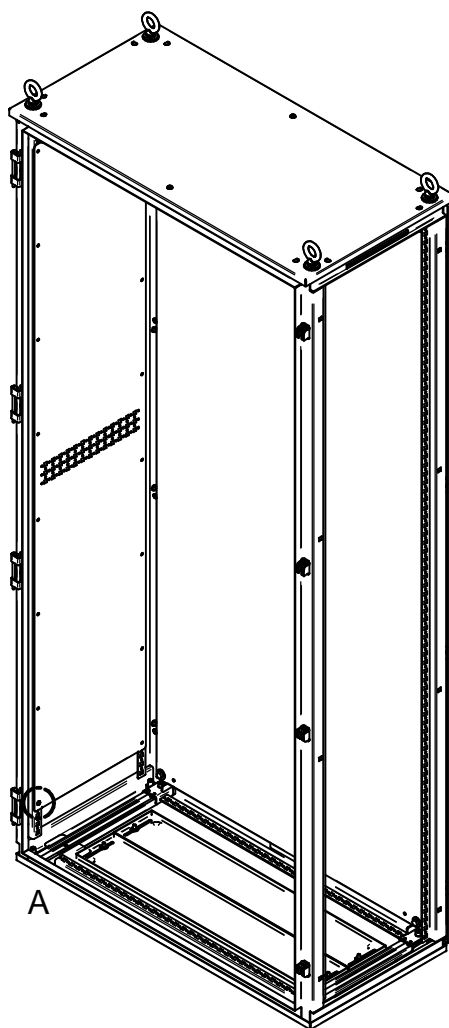

FIG 2. SIDE MTG INNER PANEL

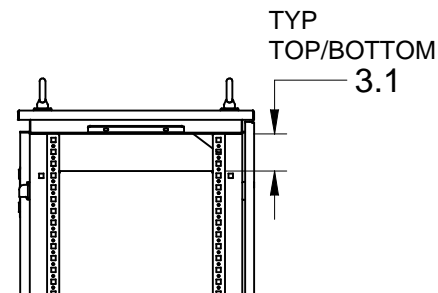
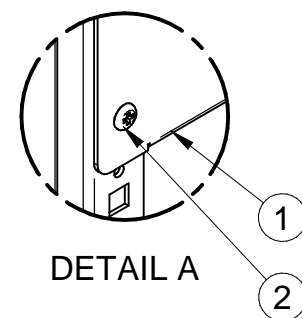

FIG 3. SIDE VIEW



DETAIL A

INSTRUCTIONS:

A) Center panel inside of cabinet frame with the flanges facing outward. Align holes and fasten using supplied self tapping screws. To center Side Mtg Inner Panel see FIG.3.

ITEM	DESCRIPTION	QTY
1	Side Mtg. Inner/Barrier Panel	1
2	Screw #12X1/2 Pan Head Phillips	-

TOOL BOX	Phillips Screw Driver

**HAMMOND
MANUFACTURING™**
www.hammondmfg.com