



Chipsmall Limited consists of a professional team with an average of over 10 year of expertise in the distribution of electronic components. Based in Hongkong, we have already established firm and mutual-benefit business relationships with customers from,Europe,America and south Asia,supplying obsolete and hard-to-find components to meet their specific needs.

With the principle of “Quality Parts,Customers Priority,Honest Operation,and Considerate Service”,our business mainly focus on the distribution of electronic components. Line cards we deal with include Microchip,ALPS,ROHM,Xilinx,Pulse,ON,Everlight and Freescale. Main products comprise IC,Modules,Potentiometer,IC Socket,Relay,Connector.Our parts cover such applications as commercial,industrial, and automotives areas.

We are looking forward to setting up business relationship with you and hope to provide you with the best service and solution. Let us make a better world for our industry!



Contact us

Tel: +86-755-8981 8866 Fax: +86-755-8427 6832

Email & Skype: info@chipsmall.com Web: www.chipsmall.com

Address: A1208, Overseas Decoration Building, #122 Zhenhua RD., Futian, Shenzhen, China



Agilent HSDL-9000 Miniature Surface-Mount Ambient Light Photo Sensor Data Sheet

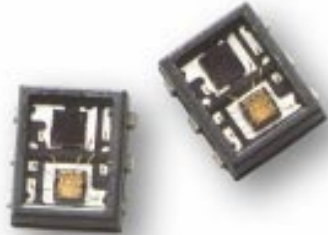
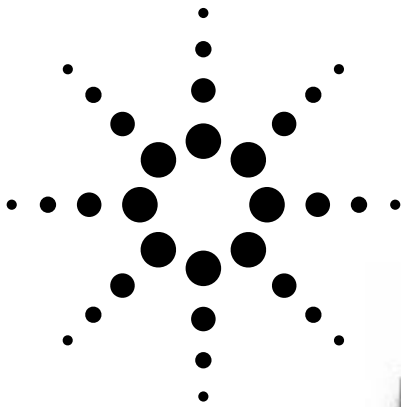

Description

The HSDL-9000 is a low cost, digital-output ambient light photo sensor in miniature industry-standard PLCC lead-free surface-mount package. It incorporates a photodiode, which peaks in human luminosity curve at 550 nm. Hence, it provides an excellent responsivity that is close to the response of human eyes, as shown in Figure 2.

With the options of three digital levels and an analog Gain Control pin to fine tune the three threshold levels to achieve better sensitivity control, the HSDL-9000 is ideal for applications in which the measurement of ambient light is used to control display backlighting. Mobile appliances such as mobile phones and PDAs that draw heavy current from the display backlighting will benefit from incorporating the HSDL-9000 in their designs to reduce the power consumption significantly.

Features

- **Excellent responsivity which peaks in the human luminosity curve at 550 nm**
Close responsivity to the human eye
- **Miniature PLCC surface-mount package**
Height – 1.1 mm
Width – 4.0 mm
Depth – 3.2 mm
- **Ease of design with digital output**
Integrated photodiode and analog to digital output circuitry
- **Enable fine control of the backlight intensity with adjustable sensitivity control**
3 digital levels
An Analog Gain Control
- **Minimum power consumption**
30 μ A typical idle (standby) current
<10 nA typical shutdown current
- **Guaranteed temperature performance**
–25°C to 85°C
- **2.7 \leq V_{CC} \leq 3.6 V**
- **Lead-free package**
- **Low cost**

Applications

- **Detection of ambient light to control display backlighting**
Mobile devices – mobile phones, PDAs
Automotive – dashboard
Consumer appliances – audio sets
- **Daylight and artificial light exposed devices**



Ordering Information

Part Number	Packaging Type	Package	Quantity
HSDL-9000	Tape and Reel	6-lead PLCC with Top Transparent Epoxy Surface	1500

Application Circuit For HSDL-9000 Ambient Light Photo Sensor

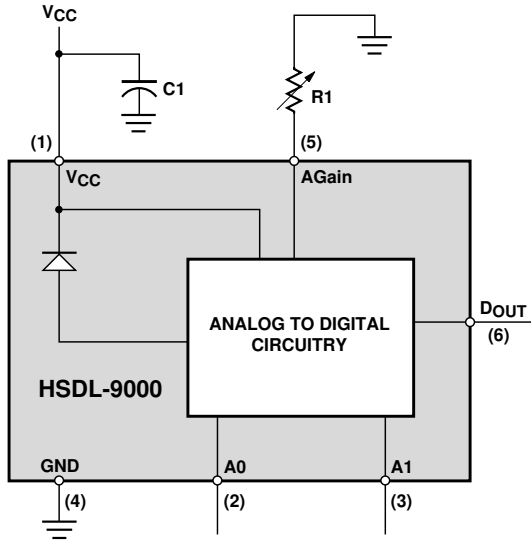

Figure 1. Functional block diagram of HSDL-9000.

I/O Pins Configuration Table

Pin	Symbol	I/O	Description	Notes
1	Vcc	I	Supply Voltage	Regulated, 2.7 to 3.6 Volt
2	A0	I	Digital Gain Level Control_0	This pin needs to be driven high or low and not left floating.
3	A1	I	Digital Gain Level Control_1	This pin needs to be driven high or low and not left floating.
4	GND	I	Ground	Connect to System Ground
5	AGain	I	Analog Gain Constant Control	If not used, leave this pin unconnected.
6	DOUT	O	Digital Output	Tri-State ^[1]

Note:

1. The HSDL-9000 is in tri-state when it is in shut down mode.

I/O Truth Table^[2]

Logic Level

A1	A0	Description	Incidence Light Threshold (Lux) ^[3]
0	0	High Gain	30
1	0	Medium Gain	81
0	1	Low Gain	164
1	1	Shut down	–

Notes:

2. AGain pin is left floating.
3. Measurements are carried out using incandescent light source.

Recommended Application Circuit Components

Component	Recommended Value
C1	1.0 μ F \pm 20%, Tantalum

Recommended R1 Values^[4]

R1	Incidence Light Threshold (Lux)		
	High Gain	Medium Gain	Low Gain
220 k Ω \pm 5%, 0.25 W	23	50	81
430 k Ω \pm 5%, 0.25 W	25	63	108
910 k Ω \pm 5%, 0.25 W	28	71	133

Note:

4. Measurements are carried out using incandescent light source.

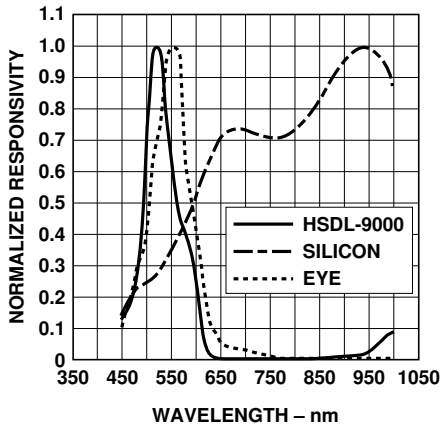

Figure 2. Relative spectral responsivity vs. wavelength.

Caution: The BiCMOS inherent to this design of this component increases the component’s susceptibility to damage from Electrostatic Discharge (ESD). It is advised that normal static precautions be taken in handling and assembly of this component to prevent damage and/or degradation, which may be induced by the ESD.

Absolute Maximum Ratings

For implementations where case to ambient thermal resistance is $\leq 50^{\circ}\text{C}/\text{W}$

Parameter	Symbol	Min.	Max.	Units	Conditions
Storage Temperature	T_S	-25	+85	$^{\circ}\text{C}$	
Operating Temperature	T_A	-25	+85	$^{\circ}\text{C}$	
Supply Voltage	V_{CC}	0	6	V	
Output Voltage: RxD	V_O	-0.5	6	V	

Recommended Operating Conditions

Parameter	Symbol	Min.	Max.	Units	Conditions
Operating Temperature	T_A	-25	+85	$^{\circ}\text{C}$	
Supply Voltage	V_{CC}	2.7	3.6	V	
Logic Input	Logic High	V_{IH}	$V_{CC} - 0.2$	V_{CC}	V
	Logic Low	V_{IL}	0	0.2	V

Electrical & Optical Specifications

Specifications (Min. & Max. values) hold over the recommended operating conditions unless otherwise noted.

Unspecified test conditions may be anywhere in their operating range.

All typical values (Typ.) are at 25°C with V_{CC} at 3.0 V unless otherwise noted.

Parameter	Symbol	Min.	Typ.	Max.	Units	Conditions
Peak Sensitivity Wavelength	λ_P		550		nm	
Viewing Angle			120		$^{\circ}$	
Logic Input	Logic High	V_{IH}	$V_{CC} - 0.2$	V_{CC}	V	
	Logic Low	V_{IL}	0	0.2	V	
Output Voltage	Logic High	V_{OH}	$V_{CC} - 0.2$	V_{CC}	V	$I_{OH} = -200 \mu\text{A}$
	Logic Low	V_{OL}	0	0.2	V	$I_{OL} = 200 \mu\text{A}$
Supply Current	I_{CC}		33	100	μA	
Shutdown Current	$I_{CC} (SD)$		10	100	nA	

HSDL-9000 Package Outline

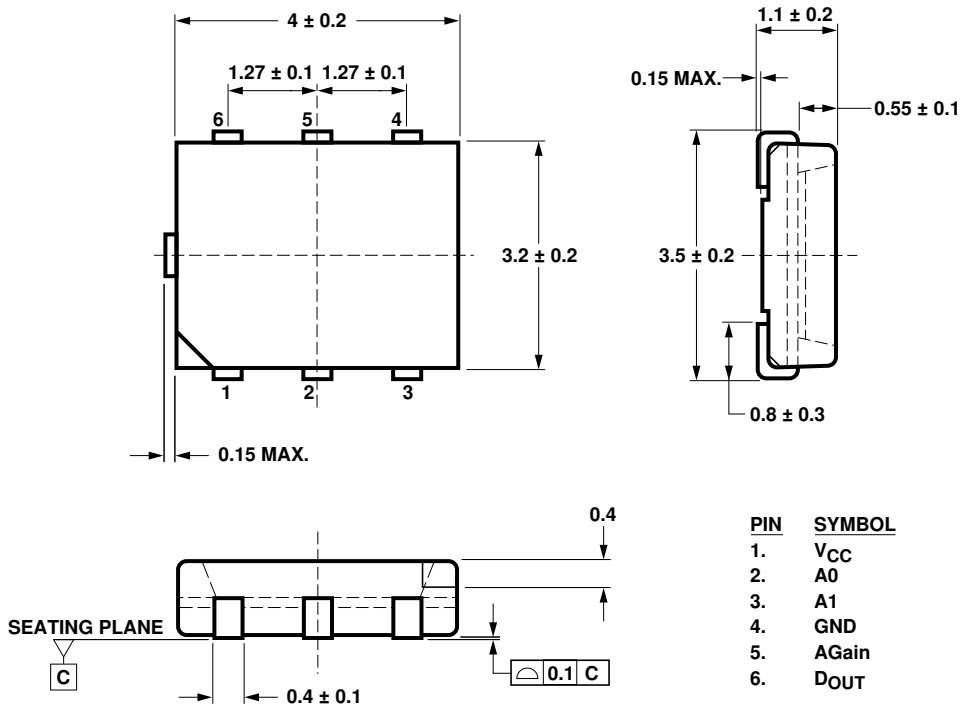

Figure 3. Package outline dimensions.

Tape and Reel Dimensions

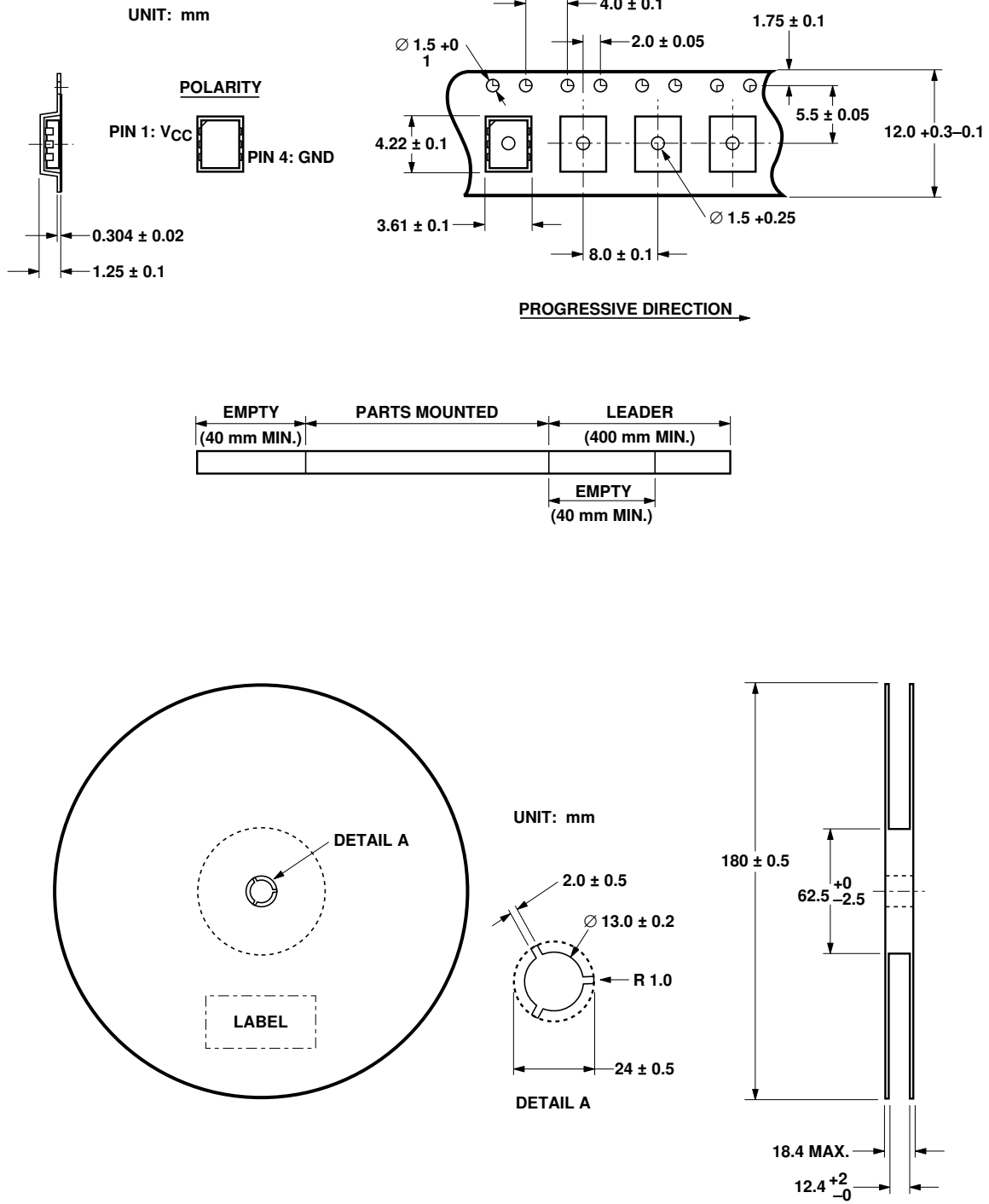

Figure 4. Tape and reel dimensions.

Moisture Proof Packaging

All HSDL-9000 options are shipped in moisture proof package. Once opened, moisture absorption begins.

This part is compliant to JEDEC Level 2a.

Baking Conditions

If the parts are not stored in dry conditions, they must be baked before reflow to prevent damage to the parts.

Package	Temp.	Time
In reels	60°C	20 hours
In bulk	125°C	5 hours

Baking should only be done once.

Recommended Storage Conditions

Storage Temperature	10°C to 30°C
Relative Humidity	below 60% RH

Time from Unsealing to Soldering

After removal from the bag, the parts should be soldered within twenty-eight days if stored at the recommended storage conditions. If times longer than 28 days are needed, the parts must be stored in a dry box.

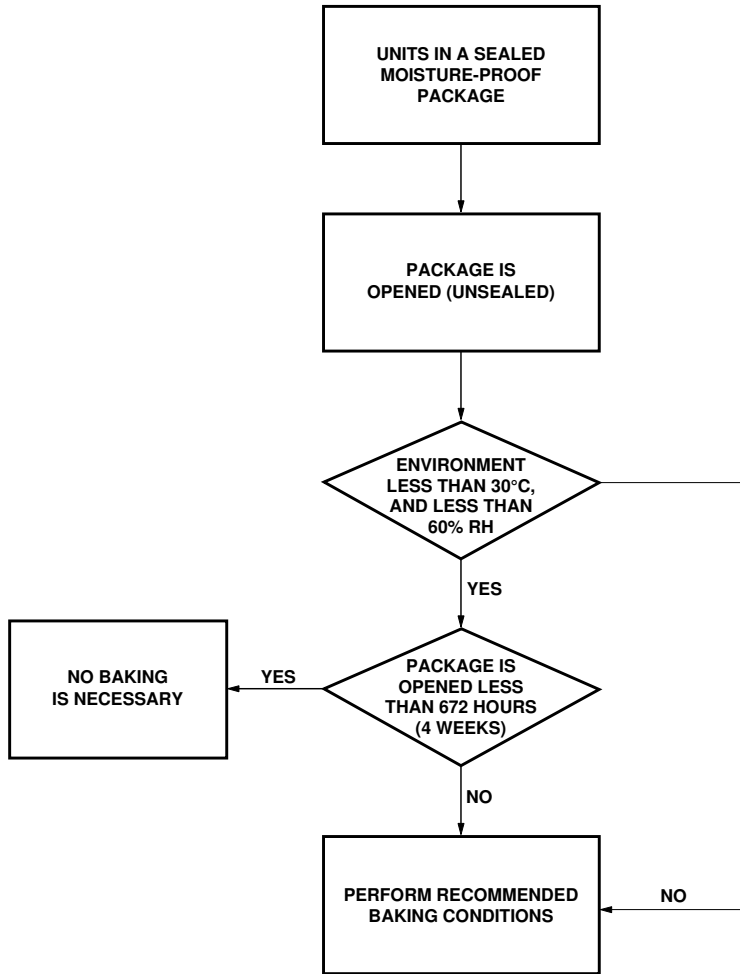

Figure 5. Baking conditions chart.

Reflow Profile

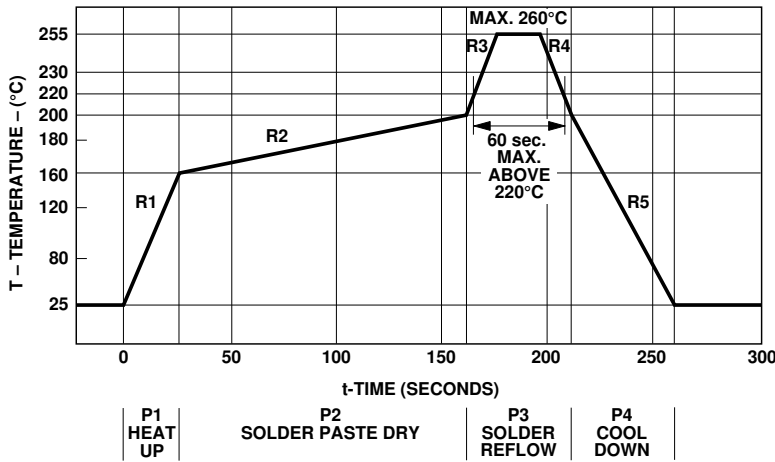

Figure 6. Reflow graph.

Process	Symbol	ΔT	Maximum $\Delta T/\Delta \text{time}$
Heat Up	P1, R1	25°C to 160°C	4°C/s
Solder Paste Dry	P2, R2	160°C to 200°C	0.5°C/s
Solder Reflow	P3, R3	200°C to 255°C (260°C at 10 seconds max.)	4°C/s
	P3, R4	255°C to 200°C	-6°C/s
Cool Down	P4, R5	200°C to 25°C	-6°C/s

The reflow profile is a straight-line representation of a nominal temperature profile for a convective reflow solder process. The temperature profile is divided into four process zones, each with different $\Delta T/\Delta \text{time}$ temperature change rates. The $\Delta T/\Delta \text{time}$ rates are detailed in the table above. The temperatures are measured at the component to printed circuit board connections.

In **process zone P1**, the PC board and I/O pins are heated to a temperature of 160°C to activate the flux in the solder paste. The temperature ramp up rate, R1, is limited to 4°C per second to allow for even heating of both the PC board and ALPS I/O pins.

Process zone P2 should be of sufficient time duration (60 to 120 seconds) to dry the solder paste. The temperature is raised to a level just below the liquidus point of the solder, usually 200°C (392°F).

Process zone P3 is the solder reflow zone. In zone P3, the temperature is quickly raised above the liquidus point of solder to 255°C (491°F) for optimum results. The dwell time above the liquidus point of solder should be between 20 and 60 seconds. It usually takes about 20 seconds to assure proper coalescence of the solder balls into liquid solder and the formation of good solder connections. Beyond a dwell time of 60 seconds, the intermetallic

growth within the solder connections becomes excessive, resulting in the formation of weak and unreliable connections. The temperature is then rapidly reduced to a point below the solidus temperature of the solder, usually 200°C (392°F), to allow the solder within the connections to freeze solid.

Process zone P4 is the cool down after solder freeze. The cool down rate, R5, from the liquidus point of the solder to 25°C (77°F) should not exceed -6°C per second maximum. This limitation is necessary to allow the PC board and transceiver's castellation I/O pins to change dimensions evenly, putting minimal stresses on the ALPS.

Appendix A : SMT Assembly Application Note

1.0 Solder Pad, Mask and Metal Stencil Aperture

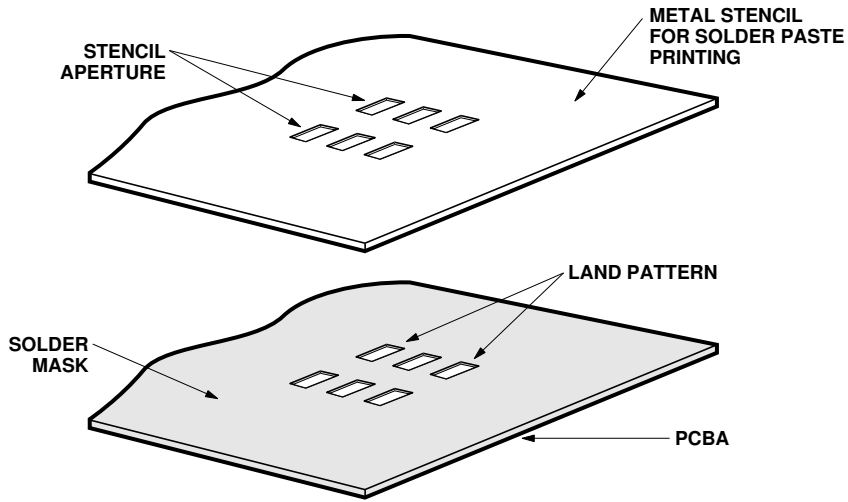

Figure 7. Stencil and PCBA.

1.1 Recommended Land Pattern

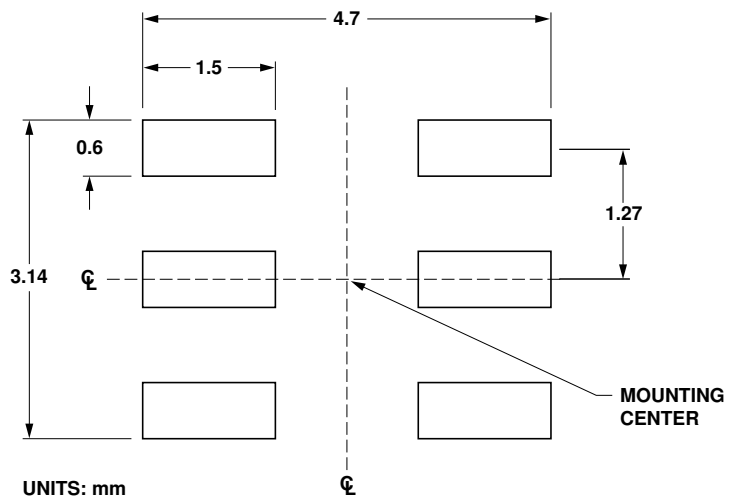

Figure 8. Stencil and PCBA.

1.2 Recommended Metal Solder Stencil Aperture

It is recommended that only a 0.152 mm (0.006 inches) thick stencil be used for solder paste printing. This is to ensure adequate printed solder paste volume and no shorting.

Aperture opening for shield pad is 1.5 mm x 0.6 mm as per land pattern.

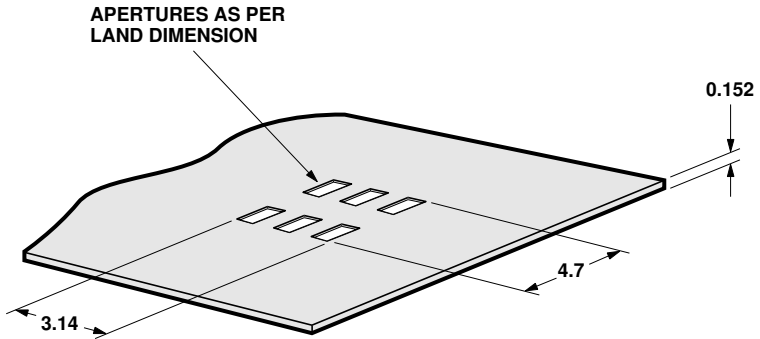

Figure 9. Solder stencil aperture.

1.3 Adjacent Land Keepout and Solder Mask Areas

Adjacent land keep-out is the **maximum space** occupied by the unit relative to the land pattern. There should be no other SMD components within this area.

The minimum solder resist strip width required to avoid solder bridging adjacent pads is **0.2 mm**.

Note: Wet/Liquid Photo-Imageable solder resist/mask is recommended.

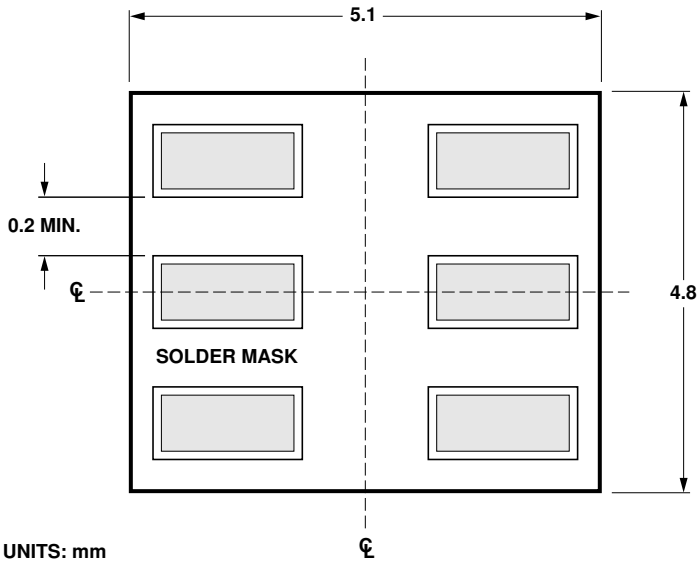

Figure 10. Adjacent land keepout and solder mask areas.

Appendix B: PCB Layout Suggestion

The following PCB layout shows a recommended layout that should result in good electrical and EMI performance. Things to note:

1. The ground plane should be continuous under the part, but should not extend under the shield trace.
2. The shield trace is a wide, low inductance trace back to the system ground.

3. C1 and C2 are optional V_{CC} filter capacitors. They may be left out if the V_{CC} is clean.

A reference layout of a 2-layer Agilent evaluation board for HSDL-9000 based on the guidelines stated above is shown below. For more details, please refer to Agilent Application Note 1114, *Infrared Transceiver PCB Board Layout for Noise Immunity*.

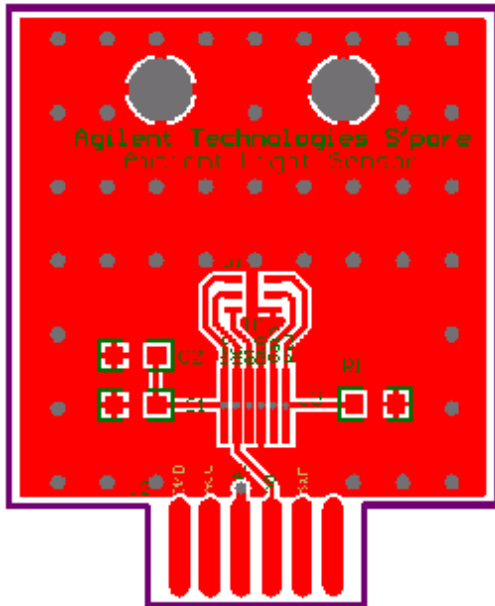

Top Layer

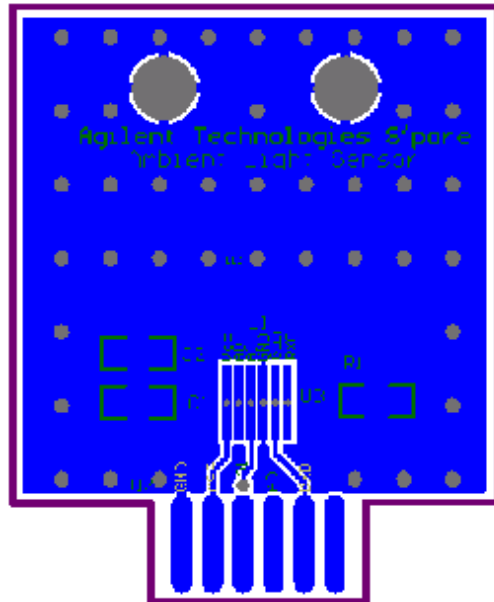

Bottom Layer

Figure 11. PCB layout suggestions.

Appendix C: Optical Window Design for HSDL-9000

Optical Window Dimensions

To ensure that the performance of the HSDL-9000 will not be affected by improper window design, there are some constraints on the dimensions and design of the window. There is a constraint on the minimum size of the window, which is placed in front of the photodiode, so that it will not affect the angular response of the HSDL-9000. This minimum dimension that is recommended will ensure at least a $\pm 35^\circ$ light reception cone.

If a smaller window is required, a light pipe or light guide can be used. A light pipe or light guide

is a cylindrical piece of transparent plastic which makes use of total internal reflection to focus the light.

The thickness of the window should be kept as minimum as possible because there is a loss of power in every optical window of about 8% due to reflection (4% on each side) and an additional loss of energy in the plastic material.

Figure 12 illustrates the two types of window that we have recommended which could either be a flat window or a flat window with light pipe.

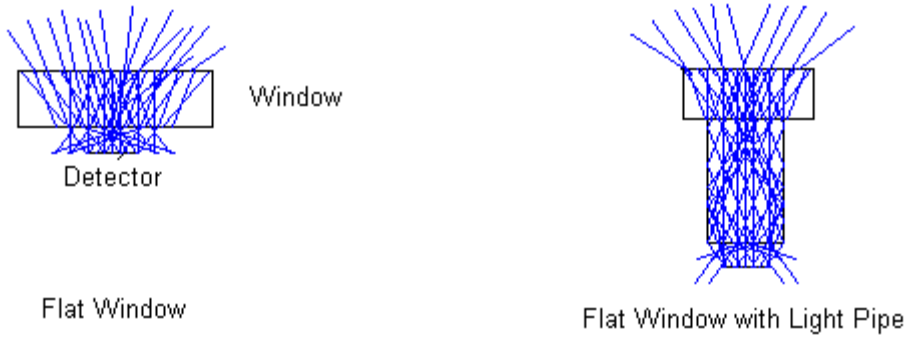

Figure 12. Recommended window design.

The table and figure below show the recommended dimensions of the window. These dimension values are based on a window thickness of 1.0 mm with a refractive index 1.585.

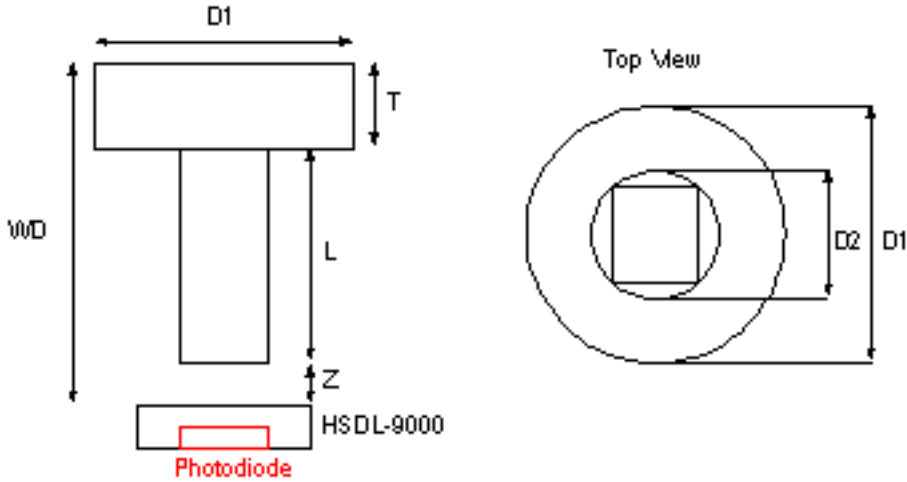

Figure 13. Recommended window dimensions.

- WD: Working Distance between window front panel & HSDL-9000
- D1: Window Diameter
- T: Thickness
- L: Length of Light Pipe
- D2: Light Pipe Diameter
- Z: Distance between window rear panel and HSDL-9000

Table 4. Recommended Dimension for Optical Window

WD (T+L+Z)	Flat Window (L = 0.0)		Flat Window with Light Pipe (D2 = 1.5; z = 0.5)	
	Z	D1	D1	L
1.5	0.5	2.25	–	–
2.0	1.0	3.25	–	–
2.5	1.5	4.25	–	–
3.0	5.00	5.00	2.5	1.5

All Dimensions are in mm.

The window should be placed directly on top of the photodiode to achieve better performance and if a flat window with a light pipe is used, dimension D2 should be 1.5 mm (same size as

the PIN) to optimize the performance of HSDL-9000. Please refer to Figure 14 for the top view of the placement of the window.

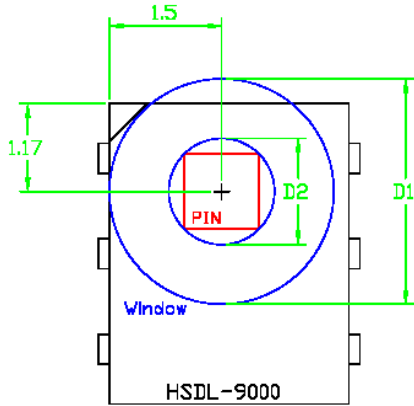

Figure 14. Placement of the window.

Optical Window Material

The material of the window is recommended to be polycarbonate. The surface finish of the plastic should be smooth, without any texture.

The recommended plastic material for use as a window is available from Bayer AG and Bayer Antwerp N. V. (Europe), Bayer Corp.(USA) and Bayer Polymers Co., Ltd. (Thailand).

Table 5. Recommended Plastic Material

Material Number	Visible Light Transmission	Refractive Index
Makrolon LQ2647	87%	1.587
Makrolon LQ3147	87%	1.587
Makrolon LQ3187	85%	1.587

www.agilent.com/semiconductors

For product information and a complete list of distributors, please go to our web site.

For technical assistance call:

Americas/Canada: +1 (800) 235-0312 or
(408) 654-8675

Europe: +49 (0) 6441 92460

China: 10800 650 0017

Hong Kong: (+65) 6756 2394

India, Australia, New Zealand: (+65) 6755 1939

Japan: (+81 3) 3335-8152 (Domestic/International),
or 0120-61-1280 (Domestic Only)

Korea: (+65) 6755 1989

Singapore, Malaysia, Vietnam, Thailand,
Philippines, Indonesia: (+65) 6755 2044

Taiwan: (+65) 6755 1843

Data subject to change.

Copyright © 2003 Agilent Technologies, Inc.

May 5, 2003

5988-9204EN



Agilent Technologies