



Chipsmall Limited consists of a professional team with an average of over 10 year of expertise in the distribution of electronic components. Based in Hongkong, we have already established firm and mutual-benefit business relationships with customers from,Europe,America and south Asia,supplying obsolete and hard-to-find components to meet their specific needs.

With the principle of "Quality Parts,Customers Priority,Honest Operation,and Considerate Service",our business mainly focus on the distribution of electronic components. Line cards we deal with include Microchip,ALPS,ROHM,Xilinx,Pulse,ON,Everlight and Freescale. Main products comprise IC,Modules,Potentiometer,IC Socket,Relay,Connector.Our parts cover such applications as commercial,industrial, and automotives areas.

We are looking forward to setting up business relationship with you and hope to provide you with the best service and solution. Let us make a better world for our industry!



Contact us

Tel: +86-755-8981 8866 Fax: +86-755-8427 6832

Email & Skype: info@chipsmall.com Web: www.chipsmall.com

Address: A1208, Overseas Decoration Building, #122 Zhenhua RD., Futian, Shenzhen, China



High Performance Surface Mount Chip LEDs

Technical Data

SunPower Series

HSMx-S660 Series
HSMx-S670 Series
HSMx-S690 Series

Features

- **High Brightness AlInGaP Material**
- **Industry Standard 2.00 x 1.25 mm Package**
- **Industry Standard 1.6 x 0.8 mm (Low Profile) Package**
- **Right Angle Package**
- **Three Colors Available**
- **Diffused Optics**
- **Compatible with IR Solder Process**
- **Available in 8 mm Tape on 7" (178 mm) Diameter Reels**

Applications

- **Keypad Backlighting**
- **LCD Backlighting**
- **Symbol Backlighting**
- **Front Panel Indicator**

Description

These chip-type LEDs utilize aluminum indium gallium phosphide (AlInGaP) material technology. The AlInGaP material has a very high luminous efficiency, capable of producing high light output over a wide range of drive currents. The 590 nm amber, 605 nm orange, and 626 nm red colors are available in three compact, low profile packages.

The HSMx-S670 is the industry standard 2.0 x 1.25 mm package, and is an excellent all around package. The HSMx-S690 is the industry standard 1.6 x 0.8 mm package. Its low 0.7 mm profile and wide viewing angle make this LED excellent for backlighting



applications. The HSMx-S660 right angle, 3.0 x 2.0 x 1.0 mm LED is optimum for side lighting applications where direct back-lighting is not practical.

All packages are compatible with IR and convective reflow soldering processes.

Device Selection Guide

Footprint (mm) [1][2]	Amber 590 nm	Orange 605 nm	Red 626 nm
1.6 x 0.8 x 0.7	HSMA-S690	HSMD-S690	HSMC-S690
2.0 x 1.25 x 0.8	HSMA-S670	HSMD-S670	HSMC-S670
3.0 x 2.0 x 1.0	HSMA-S660	HSMD-S660	HSMC-S660

Notes:

1. Dimensions in mm.
2. Tolerance ± 0.1 mm unless otherwise noted.

Package Dimensions

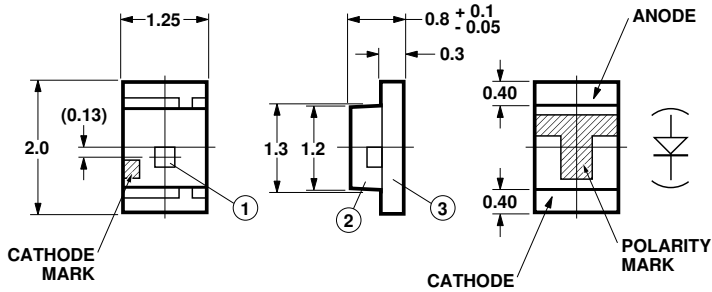

HSMx-S670 Series

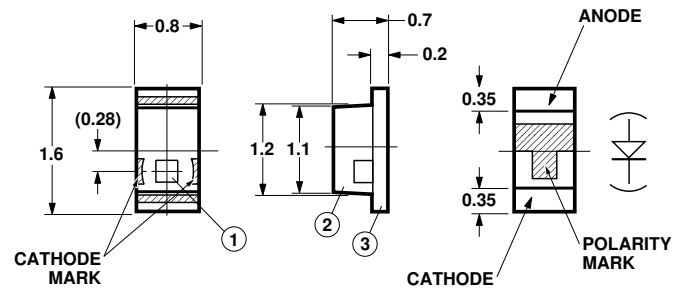

HSMx-S690 Series

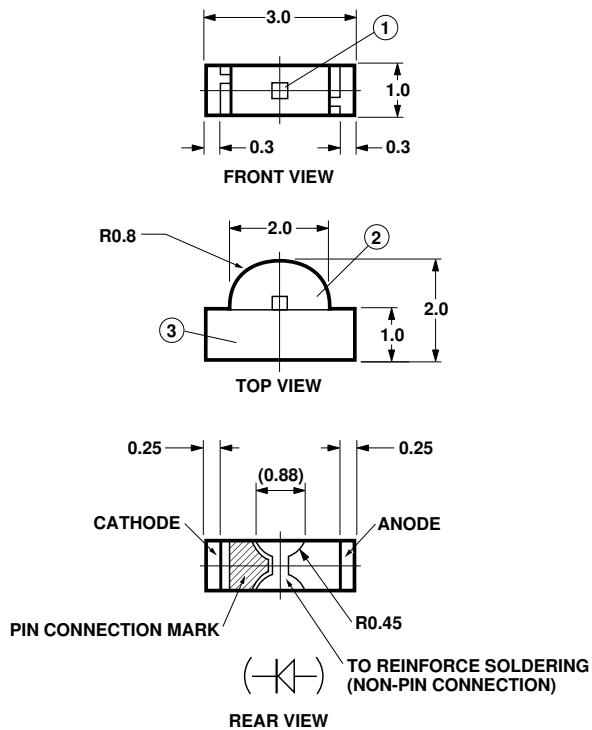

HSMx-S660 Series

Absolute Maximum Ratings at $T_A = 25^\circ\text{C}$

Parameter	HSMx-S660	HSMx-S670	HSMx-S690	Units
DC Forward Current [1][2][3][4]	30	30	30	mA
Power Dissipation	81	81	81	mW
Reverse Voltage ($I_R = 100 \mu\text{A}$)	5	5	5	V
Operating Temperature Range	-40 to +85	-40 to +85	-40 to +85	$^\circ\text{C}$
Storage Temperature Range	-40 to +100	-40 to +100	-40 to +100	$^\circ\text{C}$

Notes:

- Derate linearly as shown in Figure 4.
- Drive currents between 1 mA and 30 mA are recommended for best long term performance.
- Operating at currents below 1 mA is not recommended. Please contact your Agilent representative for further information.
- Maximum temperature for tape and reel packaging is 60°C .

Notes:

- Dimensions are in millimeters (inches).
- Tolerance, unless otherwise specified, $\pm 0.1 \text{ mm}$ ($\pm 0.004 \text{ inch}$).

Optical Characteristics at $T_A = 25^\circ\text{C}$

Part Number	Color	Luminous Intensity I_V (mcd) @ $I_F = 20 \text{ mA}^{[1]}$		Peak Wavelength λ_{peak} (nm) Typ.	Color, Dominant Wavelength $\lambda_d^{[2]}$ (nm) Typ.	Viewing Angle $2\theta_{1/2}$ Degrees $^{[3]}$ Typ.	Luminous Efficacy η_V (lm/W)
		Min.	Typ.				
HSMA-S660	Amber	16.0	65.0	592	590	155	480
HSMA-S670	Amber	16.0	65.0	592	590	165	480
HSMA-S690	Amber	16.0	65.0	592	590	165	480
HSMD-S660	Orange	16.0	65.0	609	605	155	370
HSMD-S670	Orange	16.0	65.0	609	605	165	370
HSMD-S690	Orange	16.0	65.0	609	605	165	370
HSMC-S660	Red	16.0	50.0	630	626	155	197
HSMC-S670	Red	16.0	50.0	630	626	165	197
HSMC-S690	Red	16.0	50.0	630	626	165	197

Notes:

1. The luminous intensity I_V is measured at the peak of the spatial radiation pattern which may not be aligned with the mechanical axis of the lamp package.
2. The dominate wavelength λ_d is derived from the CIE Chromaticity Diagram and represents the perceived color of the device.
3. $\theta_{1/2}$ is the off-axis angle where the luminous intensity is 1/2 the peak intensity.

Electrical Characteristics at $T_A = 25^\circ\text{C}$

Part Number	Color	Forward Voltage V_F (Volts) @ $I_F = 20 \text{ mA}$		Reverse Breakdown V_R (Volts) @ $I_R = 100 \mu\text{A}$ Min.	Capacitance C (pF), $V_F = 0$, $f = 1 \text{ MHz}$ Typ.	Thermal Resistance $R_{\theta_{J-PIN}}$ ($^\circ\text{C}/\text{W}$)
		Typ.	Max.			
HSMA-S660	Amber	1.9	2.4	5	45	600
HSMA-S670	Amber	1.9	2.4	5	45	300
HSMA-S690	Amber	1.9	2.4	5	45	300
HSMD-S660	Orange	1.9	2.4	5	45	600
HSMD-S670	Orange	1.9	2.4	5	45	300
HSMD-S690	Orange	1.9	2.4	5	45	300
HSMC-S660	Red	1.9	2.4	5	45	600
HSMC-S670	Red	1.9	2.4	5	45	300
HSMC-S690	Red	1.9	2.4	5	45	300

Yellow/Amber Color Bins^[1]		
Dom. Wavelength (nm)		
Bin ID	Min.	Max.
A	582.0	584.5
B	584.5	587.0
C	587.0	589.5
D	589.5	592.0
E	592.0	594.5
F	594.5	597.0

Tolerance: ± 0.5 nm.

Orange Color Bins^[1]		
Dom. Wavelength (nm)		
Bin ID	Min.	Max.
A	597.0	600.0
B	600.0	603.0
C	603.0	606.0
D	606.0	609.0
E	609.0	612.0
F	612.0	615.0

Tolerance: ± 1 nm.

Note:

1. Bin categories are established for classification of products. Products may not be available in all bin categories. Please contact your Agilent representative for information on currently available bins.

Light Intensity (Iv) Bin Limits^[1]		
Intensity (mcd)		
Bin ID	Min.	Max.
A	0.11	0.18
B	0.18	0.29
C	0.29	0.45
D	0.45	0.72
E	0.72	1.10
F	1.10	1.80
G	1.80	2.80
H	2.80	4.50
J	4.50	7.20
K	7.20	11.20
L	11.20	18.00
M	18.00	28.50
N	28.50	45.00
P	45.00	71.50
Q	71.50	112.50
R	112.50	180.00
S	180.00	285.00
T	285.00	450.00
U	450.00	715.00
V	715.00	1125.00
W	1125.00	1800.00
X	1800.00	2850.00
Y	2850.00	4500.00

Tolerance \pm 15%

Note:

1. Bin categories are established for classification of products. Products may not be available in all bin categories. Please contact your Agilent representative for information on currently available bins.

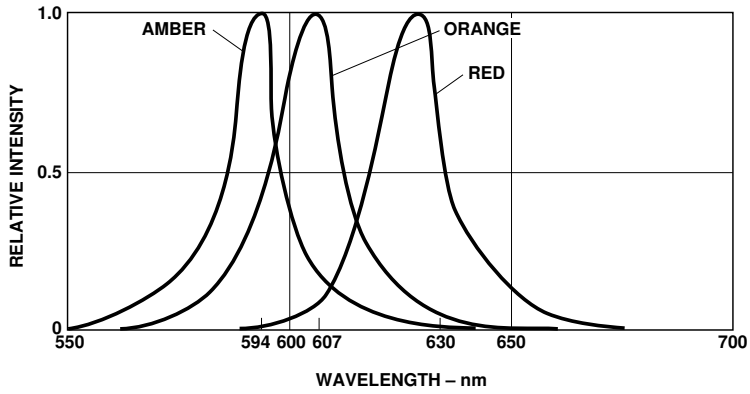

Figure 1. Relative Intensity vs. Wavelength.

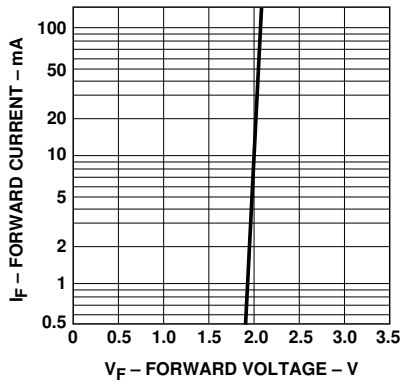

Figure 2. Forward Current vs. Forward Voltage.

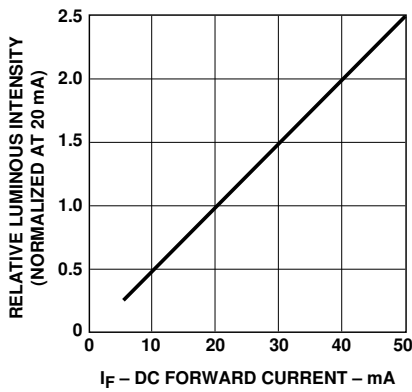

Figure 3. Relative Luminous Intensity vs. Forward Current.

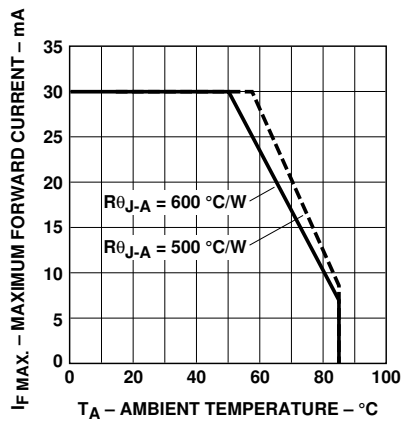

Figure 4. Maximum Forward Current vs. Ambient Temperature.

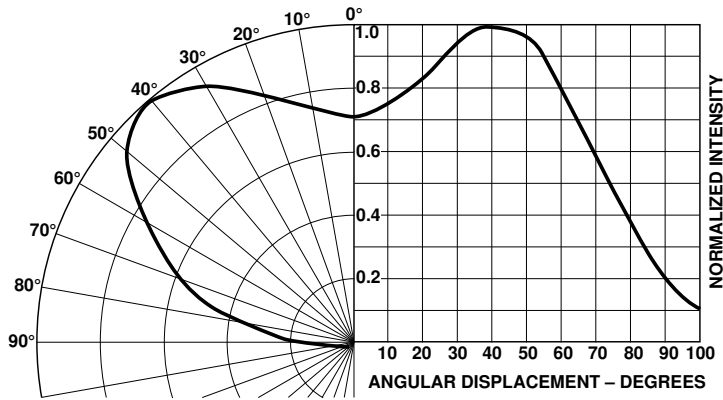

Figure 5. Relative Luminous Intensity vs. Angular Displacement for HSMx-S660.

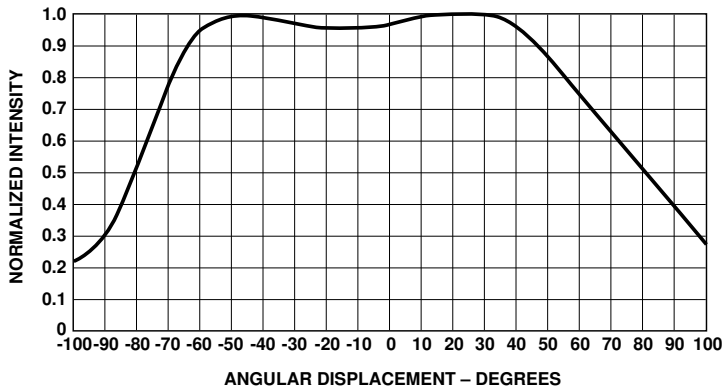

Figure 6. Relative Luminous Intensity vs. Angular Displacement for HSMx-S670.

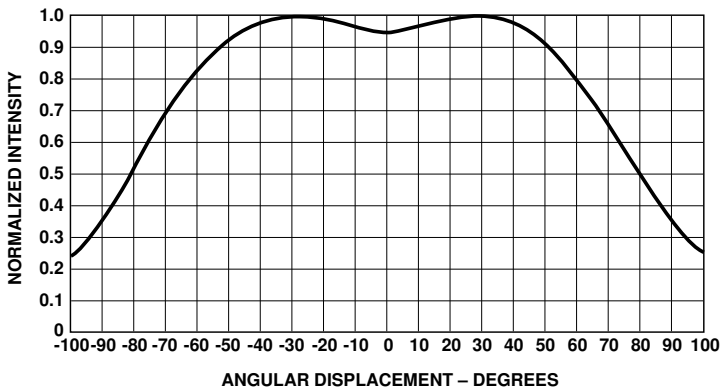

Figure 7. Relative Luminous Intensity vs. Angular Displacement for HSMx-S690.

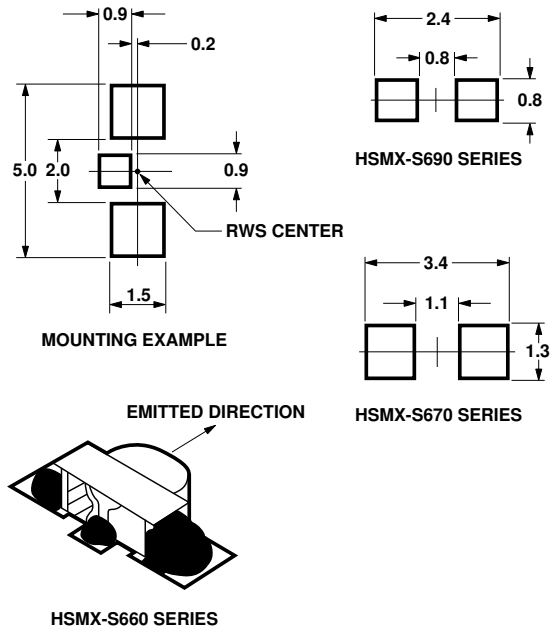

Figure 8. Recommended Solder Patterns.

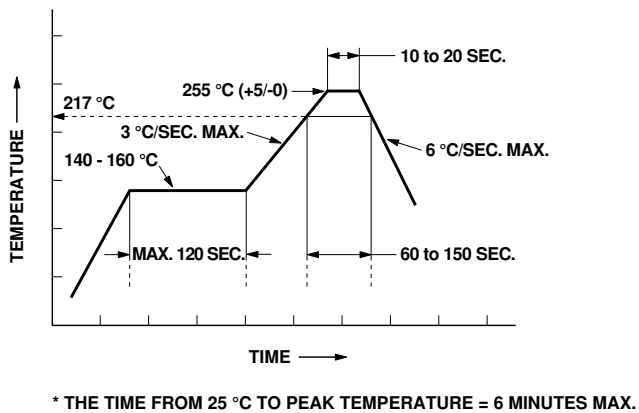

Figure 9. Recommended Pb-Free IR Reflow Profile.

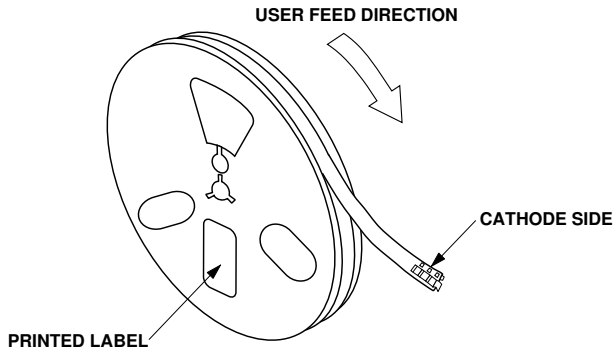

Figure 10. Reeling Orientation.

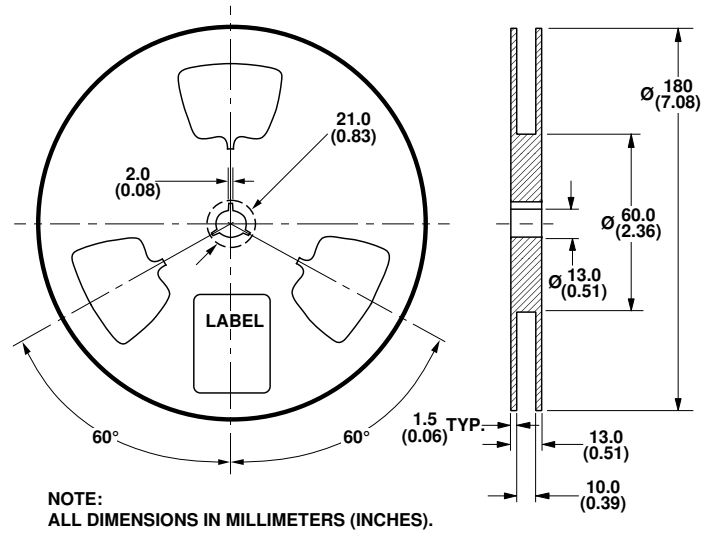

Figure 11. Reel Dimensions.

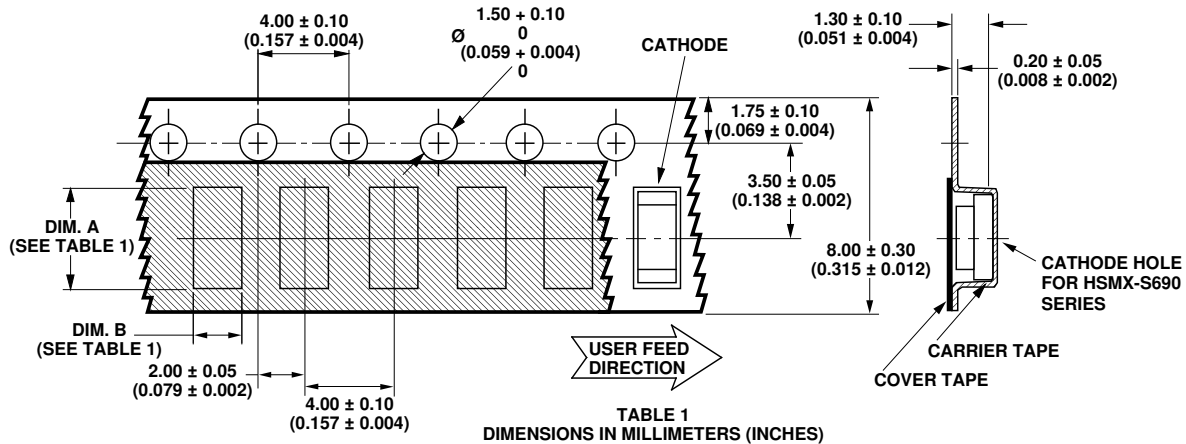

TABLE 1
DIMENSIONS IN MILLIMETERS (INCHES)

PART NUMBER	DIM. A ± 0.10 (0.004)	DIM. B ± 0.10 (0.004)
HSMX-S670 SERIES	2.25 (0.089)	1.45 (0.057)
HSMX-S690 SERIES	1.85 (0.073)	1.00 (0.039)

Figure 12. Tape Dimensions HSMx-S670, HSMx-S690.

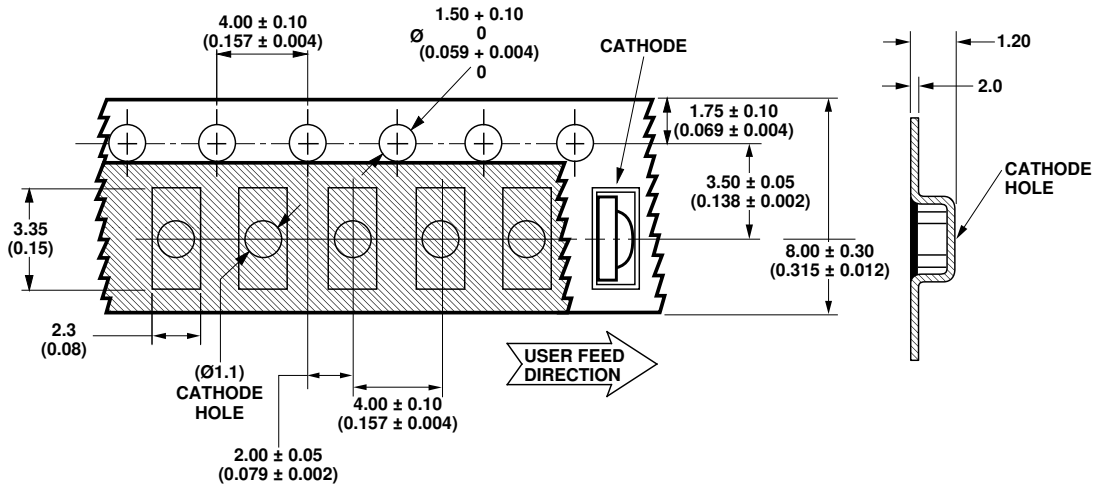

Figure 13. Tape Dimensions HSMx-S660.

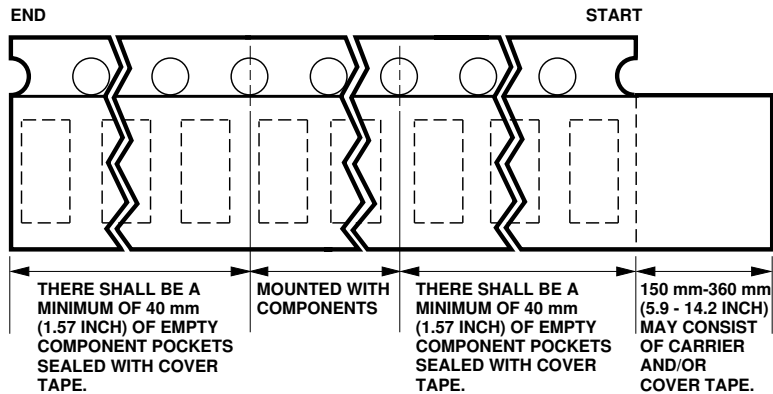

Figure 14. Tape Leader and Trailer Dimensions.

Storage Condition: 5 to 30° C @ 60% RH max.

Baking is required under the condition:

- the blue silica gel indicator becoming white/transparent color
- the pack has been opened for more than 1 week

Baking recommended condition: 60 +/- 5° C for 20 hours.

www.agilent.com/semiconductors

For product information and a complete list of distributors, please go to our web site.

For technical assistance call:

Americas/Canada: +1 (800) 235-0312 or
(916) 788-6763

Europe: +49 (0) 6441 92460

China: 10800 650 0017

Hong Kong: (+65) 6756 2394

India, Australia, New Zealand: (+65) 6755 1939

Japan: (+81 3) 3335-8152 (Domestic/International), or 0120-61-1280 (Domestic Only)

Korea: (+65) 6755 1989

Singapore, Malaysia, Vietnam, Thailand,
Philippines, Indonesia: (+65) 6755 2044

Taiwan: (+65) 6755 1843

Data subject to change.

Copyright © 2003 Agilent Technologies, Inc.

Obsoletes 5988-7964EN

October 2, 2003

5989-0164EN