



Chipsmall Limited consists of a professional team with an average of over 10 year of expertise in the distribution of electronic components. Based in Hongkong, we have already established firm and mutual-benefit business relationships with customers from,Europe,America and south Asia,supplying obsolete and hard-to-find components to meet their specific needs.

With the principle of “Quality Parts,Customers Priority,Honest Operation,and Considerate Service”,our business mainly focus on the distribution of electronic components. Line cards we deal with include Microchip,ALPS,ROHM,Xilinx,Pulse,ON,Everlight and Freescale. Main products comprise IC,Modules,Potentiometer,IC Socket,Relay,Connector.Our parts cover such applications as commercial,industrial, and automotives areas.

We are looking forward to setting up business relationship with you and hope to provide you with the best service and solution. Let us make a better world for our industry!



Contact us

Tel: +86-755-8981 8866 Fax: +86-755-8427 6832

Email & Skype: info@chipsmall.com Web: www.chipsmall.com

Address: A1208, Overseas Decoration Building, #122 Zhenhua RD., Futian, Shenzhen, China





**MINITEK HAND-TOOL
HT-151 and HT-152**

FCI MANUAL P/N 166647-001





Table of Contents

<u>INTRODUCTION</u>	4
General Description.....	4
Part Names	4
Terminal and Applicable Wire Range	5
<u>OPERATION</u>	6
Wire Stripping	6
Crimping Procedure	6
<u>SERVICE</u>	7
Service	7
Parts Replacement.....	7
HT-151 MINITEK (AWG 26-30).....	9
HT-152 MINITEK (AWG 32-36).....	10

REFERENCE DOCUMENTS

FORM # E-3246- - Hand Tool Warranty

FORM # E-3247- - FCI Electronics Address List

Introduction

General Description

This instruction manual covers application and maintenance for HT-151 and HT-152 designed for strip version of MINITEK Terminal.

Please read these instructions thoroughly before using the Hand-Tool.

Part Names

See Figure 1 for part names of the Hand-Tool

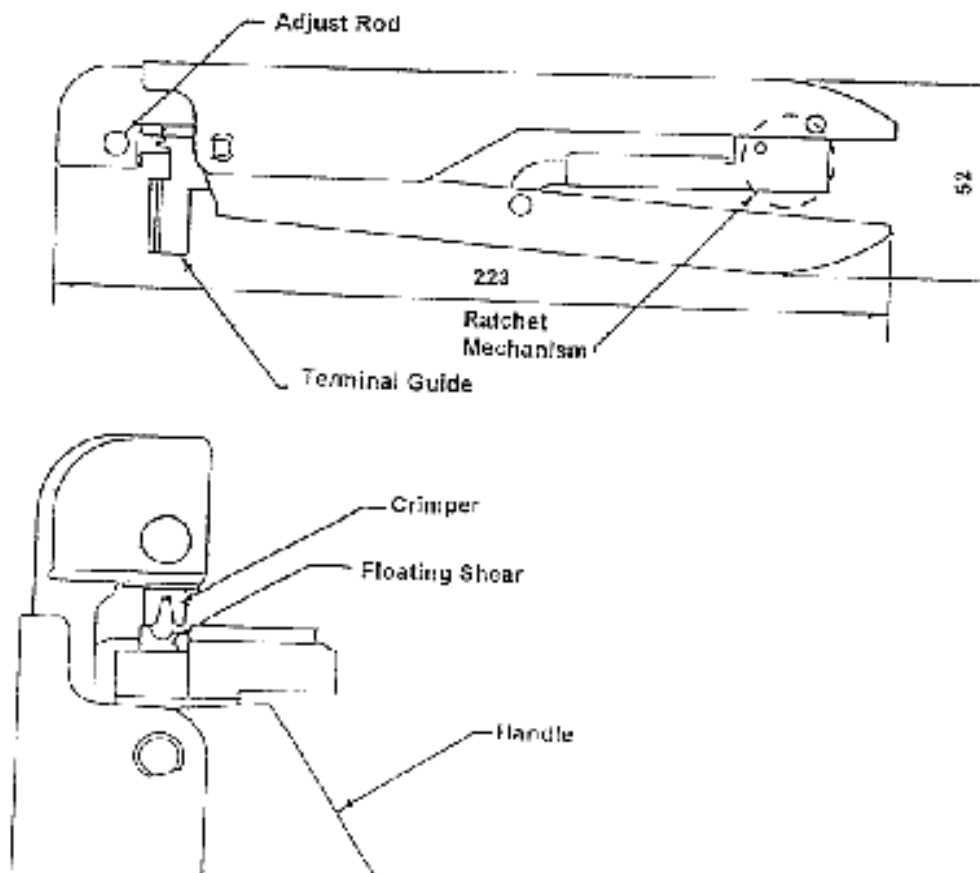

Figure 1

Terminal and Applicable Wire Range

HT-151 is used to crimp the terminal with wires consisting of conductor ranging from 0.05 to 0.13mm² (AWG 30-26) and insulation of 1.4 mm Max. diameter in nominal size. HT-152 is used to crimp the terminal with wires having conductor from 0.01 to 0.03 mm² (AWG #36-32) and insulation of 0.6 mm Max diameter.

The crimping conditions of each hand-tool are as shown in Table 1.

The crimper of this hand-tool has two crimping areas each of which is applicable to a different range of wire.

The crimper can be easily changed by pulling off the adjust rod shown in Figure 1. Figure 2 shows the crimpers removed from the hand-tool.

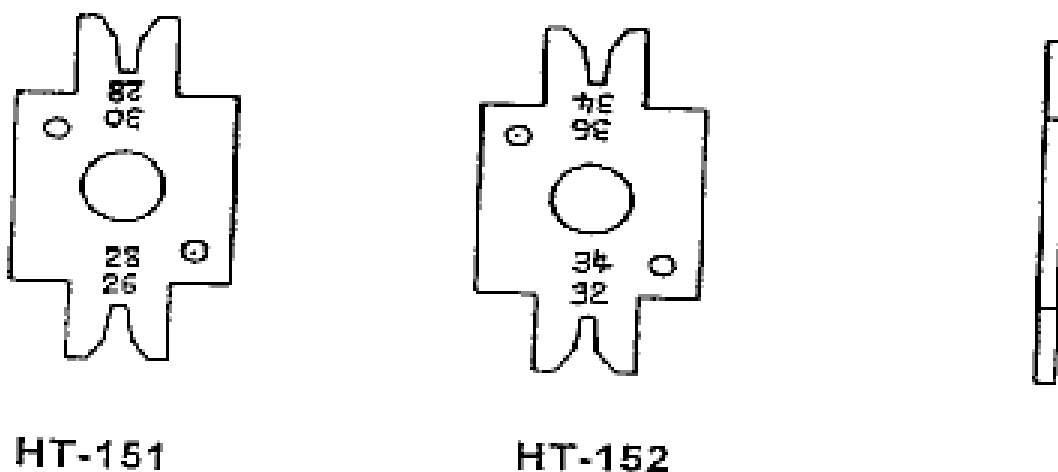

Figure 2

The crimper has marks showing AWG wire size applicable to each crimping area. Refer to the marks in Figure 2 and Table 1, including Terminal P/N, Applicable Wire Size and Insulation Diameter when crimping.

TABLE 1

CRIMP SPEC				
Terminal	Hand-tool	Wire Range AWG#	Wire Barrel Height (mm.)	Ins. Barrel Height (mm.)
77138-001	HT-151	26 – 28	0.60 - 0.65	1.4 Max.
		28 - 30	0.57 - 0.62	
77139-001	HT-152	32 - 34	0.43 - 0.48	1.35 Ref.
		34 - 36	0.42 - 0.47	

Operation

Wire Stripping

Make sure stripped length of the wire is in the range of 1.2 to 2.2 mm.

Be careful not to make cuts or nicks in the strands during the stripping operation.

The use of improperly prepared wire may cause insufficient crimp performance.

Crimping Procedure

- (1) Hold handles with the stamp of wire size (shown in Figure 2) facing the operator. Close the handles until ratchet releases to open handles.
- (2) Feed terminals one at a time (cut to proper length) into the crimping area of hand-tool through terminal guide (see Figure 3) by hand.
- (3) Insert stripped wire into wire barrel of terminal as (shown in Figure 3). Straighten wire before placing in hand-tool.
- (4) Close handles with wire held in crimping area until ratchet releases. This hand-tool is provided with a ratchet mechanism on its handles in order to obtain an appropriate crimp condition. Close the handle fully to reach the proper crimp condition.
- (5) Remove terminal after crimping.
- (6) Lightly oil every third to fourth wire and insulation terminal barrels using terminal lubrication (IE Stoner E805).

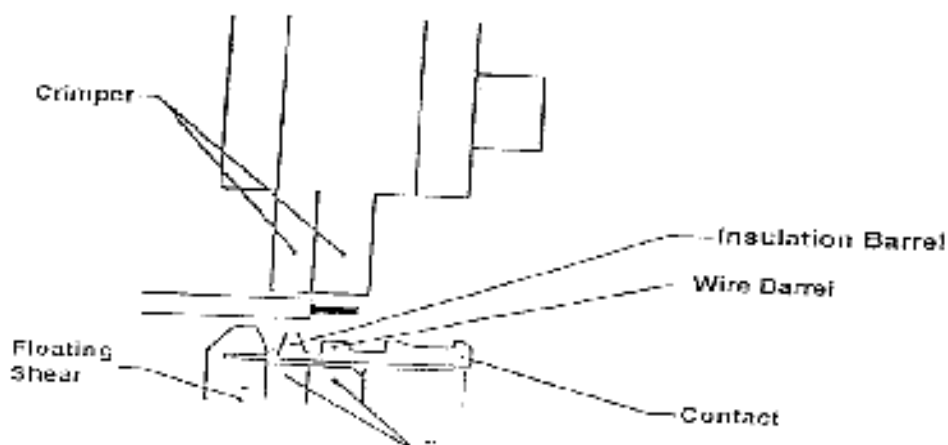

Figure 3

Service

Service

- In order to assure that continued use of the hand-tool can be made under the proper conditions, pay attention to following:
 - (1) Don't drop, throw or use the hand-tool as a hammer.
 - (2) Periodically lubricate bearing surfaces to prevent rust build-up.
 - (3) After use of the hand-tool, wipe the tool particularly the crimping area to prevent rust, scratches or dents. Keep the handles closed to prevent crimping area from dirt and foreign particles when the hand-tool is not in use.
- **WHAT TO DO IF YOU NEED SERVICE:**
In the event service or technical help is needed FCI Electronics provides a toll free number. For service or technical help call 1-800-843-6911.

Parts Replacement

- **PARTS REPLACEMENT:**
When calling for spare parts, have part number(s) ready for the customer service person. Number(s) can be obtained from the reference drawings located in the back of this manual. Spare part orders call 1-800-222-2194 and ask for CUSTOMER SERVICE.

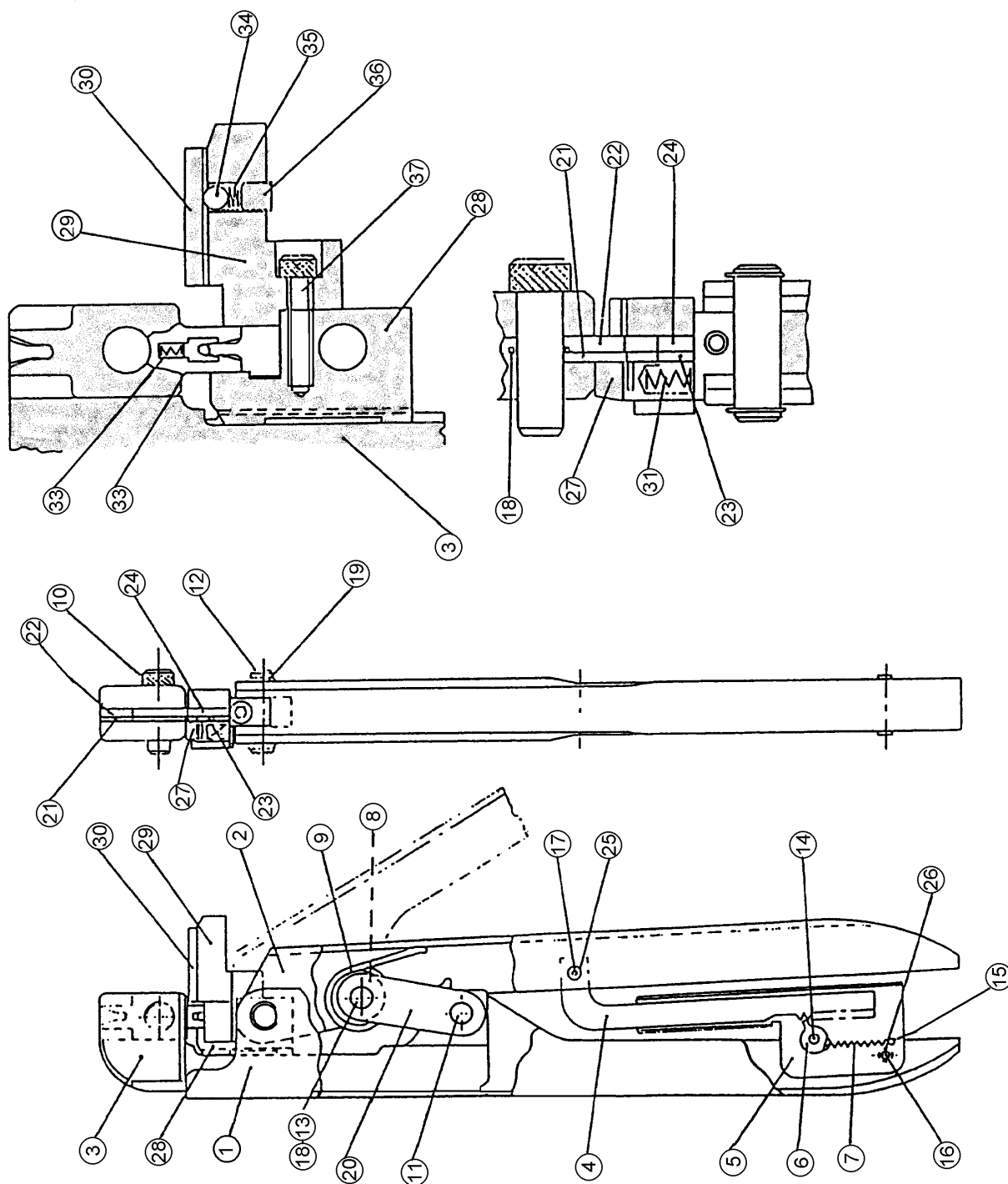

Figure 4



HT-151 MINITEK (AWG 26-30)

	DWG NO.	DESCRIPTION			DWG NO.	DESCRIPTION	
1	HT-02-001	HANDLE-A	1	20	HT-02-020	LINK	2
2	HT-02-002	HANDLE-B	1	21	411219	INS CRIMPER	1
3	HT-03-003	SLIDE BLOCK	1	22	411217	WIRE CRIMPER	1
4	HT-02-004	RATCHET ROD	1	23	411220	INS ANVIL	1
5	HT-02-005	HOUSING	1	24	411218	WIRE ANVIL	1
6	HT-02-006	RATCHET	1	25	HT-02-025	RING RATCHET ROD	2
7	HT-02-007	SPRING RATCHET	1	26	HT-02-026	SPACER HOUSING	2
8	JT-02-008	SPACER COLLAR	1	27	HT-03-027	FLOATING SHEAR	1
9	HT-03-009	SPRING RELEASE	1	28	HT-03-028	ANVIL HOLDER	1
10	HT-02-010	ADJUST ROD	1	29	HT-03-029 HT-03-01D	TERMINAL GUIDE	1
11	HT-03-011	LINK PIN-A	1	30	HT-03-030 HT-03-01D	STRIP GUIDE	1
12	HT-02-012	CENTER PIN	1	31	HT-03-031	SPRING FLOATING SHEAR	1
13	HT-02-013	LINK PIN-B	1	32	HT-03-032	WIRE STRIPPER	2
14	HT-02-014	SHOULDER PIN	1	33	HT-03-033	SPRING STRIPPER	2
15	HT-02-015	SPRING HANGER	1	34	HT-03-034	ADJUST BALL	1
16	HT-02-016	SEM TUBULAR RIVET-A	1	35	HT-03-035	SPRING ADJUST	1
17	HT-02-017	SEM TUBULAR RIVET-B	1	36	HT-03-036	SCREW SOC SET (M 4x4)	1
18	HT-02-018	STOP RING	2	37	HT-03-037	SCREW SOC HD. CAP (M 3x15)	1
19	HT-02-019	E-C RING	2				

HT-152 MINITEK (AWG 32-36)

	DWG NO.	DESCRIPTION	QTY		DWG NO.	DESCRIPTION	QTY
1	HT-02-001	HANDLE-A	1	20	HT-02-020	LINK	2
2	HT-02-002	HANDLE-B	1	21	411223	INS CRIMPER	1
3	HT-03-003	SLIDE BLOCK	1	22	411221	WIRE CRIMPER	1
4	HT-02-004	RATCHET ROD	1	23	411224	INS ANVIL	1
5	HT-02-005	HOUSING	1	24	411222	WIRE ANVIL	1
6	HT-02-006	RATCHET	1	25	HT-02-025	RING RATCHET ROD	2
7	HT-02-007	SPRING RATCHET	1	26	HT-02-026	SPACER HOUSING	2
8	HT-02-008	SPACER COLLAR	1	27	HT-03-027	FLOATING SHEAR	1
9	HT-03-009	SPRING RELEASE	1	28	HT-03-028	ANVIL HOLDER	1
10	HT-02-010	ADJUST ROD	1	29	HT-03-029 HT-03-01D	TERMINAL GUIDE	1
11	HT-03-011	LINK PIN-A	1	30	HT-03-030 HT-03-01D	STRIP GUIDE	1
12	HT-02-012	CENTER PIN	1	31	HT-03-031	SPRING FLOATING SHEAR	1
13	HT-02-013	LINK PIN-B	1	32	HT-03-032	WIRE STRIPPER	2
14	HT-02-014	SHOULDER PIN	1	33	HT-03-033	SPRING STRIPPER	2
15	HT-02-015	SPRING HANGER	1	34	HT-03-034	ADJUST BALL	1
16	HT-02-016	SEM TUBULAR RIVET-A	1	35	HT-03-035	SPRING ADJUST	1
17	HT-02-017	SEM TUBULAR RIVET-B	1	36	HT-03-036	SCREW SOC SET (M 4X4)	1
18	HT-02-018	STOP RING	2	37	HT-03-037	SCREW SOC HD. CAP (M 3X15)	1
19	HT-02-019	E-C RING	2				