



Chipsmall Limited consists of a professional team with an average of over 10 year of expertise in the distribution of electronic components. Based in Hongkong, we have already established firm and mutual-benefit business relationships with customers from,Europe,America and south Asia,supplying obsolete and hard-to-find components to meet their specific needs.

With the principle of “Quality Parts,Customers Priority,Honest Operation,and Considerate Service”,our business mainly focus on the distribution of electronic components. Line cards we deal with include Microchip,ALPS,ROHM,Xilinx,Pulse,ON,Everlight and Freescale. Main products comprise IC,Modules,Potentiometer,IC Socket,Relay,Connector.Our parts cover such applications as commercial,industrial, and automotives areas.

We are looking forward to setting up business relationship with you and hope to provide you with the best service and solution. Let us make a better world for our industry!



Contact us

Tel: +86-755-8981 8866 Fax: +86-755-8427 6832

Email & Skype: info@chipsmall.com Web: www.chipsmall.com

Address: A1208, Overseas Decoration Building, #122 Zhenhua RD., Futian, Shenzhen, China



REVISION R

DO NOT SCALE FROM THIS PRINT

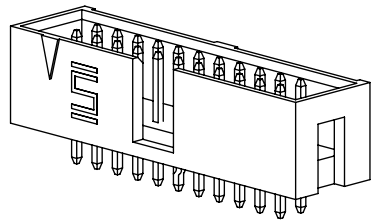

HTST-1XX-XX-XX-D-XX-XX

No OF POSITIONS
 -02 (STRAIGHT ONLY)
 -03 THRU -18, -20, -24,
 -25, -28, -30, -32 & -36

POLARIZATION OPTION
 -XX: INDICATES POSITION OMITTED

OPTION
 BLANK: STRAIGHT (STYLES -04 & -05 N/A)
 -RA: RIGHT ANGLE (STYLES -01, -02 & -03 N/A)
 -LL: LOCKING LEAD (STRAIGHT ONLY)
 -LA: -RA OPTION WITH -LL OPTION

ROW SPECIFICATION
 -D: DOUBLE ROW
 (USE HTST-XX-D)

LEAD STYLE
 SEE TABLE 1
 & TABLE 2

PLATING SPECIFICATION

-G: GOLD, 10 Au / 50 Ni MIN ON CONTACT, 3 Au / 50 Ni MIN ON TAIL
 -T: MATTE TIN, CONTACT AND TAIL
 -S: SELECTIVE, 30 Au / 50 Ni MIN ON CONTACT, MATTE TIN TAIL
 -L: LIGHT SELECTIVE, 10 Au / 50 Ni MIN ON CONTACT, MATTE TIN TAIL
 -H: HEAVY GOLD, 30 Au / 50 Ni MIN ON CONTACT, 3Au / 50 Ni MIN ON TAIL
 -F: FLASH SELECTIVE, 3 Au / 50 Ni ON CONTACT, MATTE TIN TAIL
 -TM: MATTE TIN CONTACT AND TAIL
 -SM: SELECTIVE, 30 Au / 50 Ni ON CONTACT, MATTE TIN TAIL
 -FM: FLASH SELECTIVE, 3 Au / 50 Ni MIN ON CONTACT, MATTE TIN TAIL
 -LM: LIGHT SELECTIVE, 10 Au / 50 Ni MIN, MATTE TIN TAIL

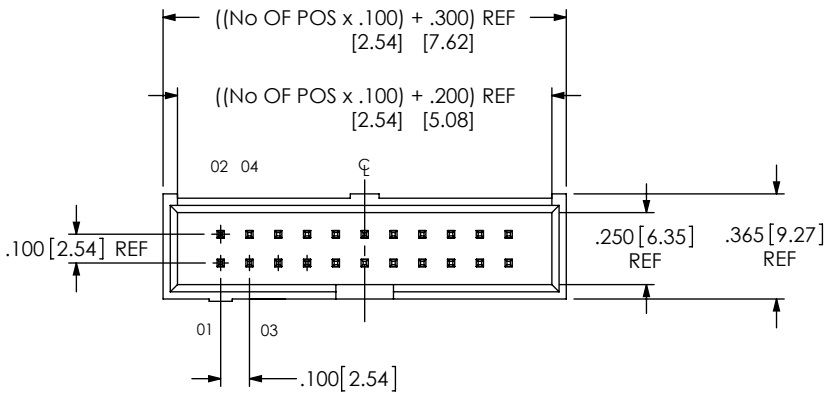

TABLE 1

LEAD STYLE	"A"	TERMINAL
-01	.480 [12.19]	T-1S6-17-XX-2
-02	.530 [13.46]	T-1S6-08-XX-2
-03	.930 [23.62]	T-1S6-11-XX-2

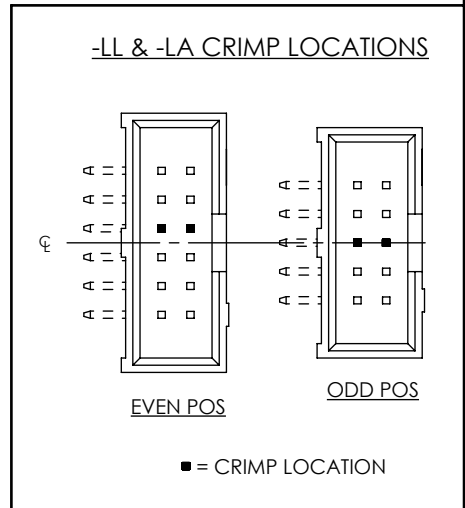
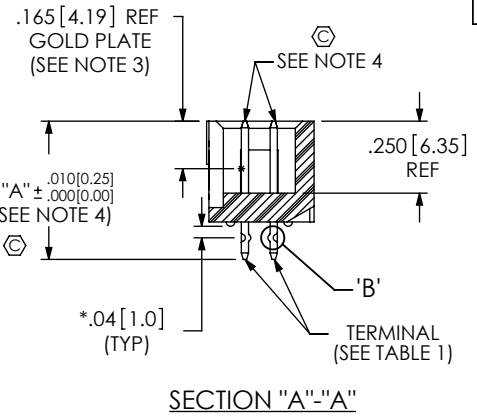
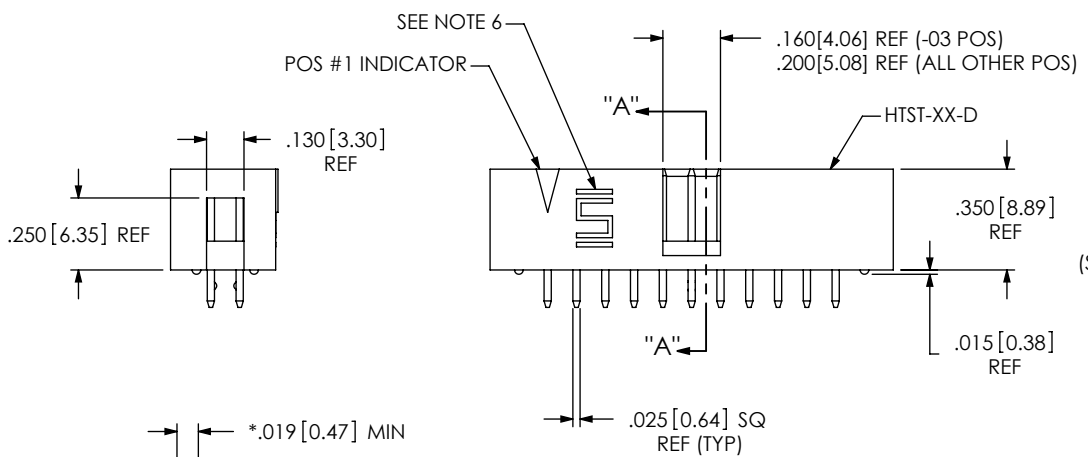

FIG 1
 HTST-111-01-XX-D-LL SHOWN
 * DIMENSIONS APPLY WHEN USING -LL OPTION ONLY

DETAIL 'B'
 SCALE 6:1

NOTES:

- $\text{\textcircled{C}}$ REPRESENTS A CRITICAL DIMENSION.
- TERMINAL PUSHOUT FORCE: 3 lbs.
- ASSEMBLE GOLD PLATED END AS SHOWN.
- TERMINALS TO BE FLUSH TO .010 [.25] BELOW TOP OF SHROUD.

UNLESS OTHERWISE SPECIFIED, DIMENSIONS ARE IN INCHES. TOLERANCES ARE:
 DECIMALS ANGLES
 .XX: \pm .01 [.3] 2°
 .XXX: \pm .005 [.13]
 .XXXX: \pm .0020 [.051]

PROPRIETARY NOTE
 THIS DOCUMENT CONTAINS INFORMATION CONFIDENTIAL AND PROPRIETARY TO SAMTEC, INC. AND SHALL NOT BE REPRODUCED OR TRANSFERRED TO OTHER DOCUMENTS OR DISCLOSED TO OTHERS OR USED FOR ANY PURPOSE OTHER THAN THAT WHICH IT WAS OBTAINED WITHOUT THE EXPRESSED WRITTEN CONSENT OF SAMTEC, INC.



520 PARK EAST BLVD, NEW ALBANY, IN 47150
 PHONE: 812-944-6733 FAX: 812-948-5047
 e-Mail: info@SAMTEC.com code: 55322

MATERIAL: DO NOT SCALE DRAWING SHEET SCALE: 1.5:1
INSULATOR: LCP, UL 94 VO
 COLOR: NATURAL
TERMINAL: PHOS BRONZE
 F:\DWG\MISC\MKTG\HTST-1XX-XX-XX-D-XX-XX-MKT.SLDDRW

DESCRIPTION: HIGH TEMP TOP SHROUD TERMINAL STRIP
DWG. NO. HTST-1XX-XX-XX-D-XX-XX
BY: BRATCHER 01/16/04 **SHEET 1 OF 2**

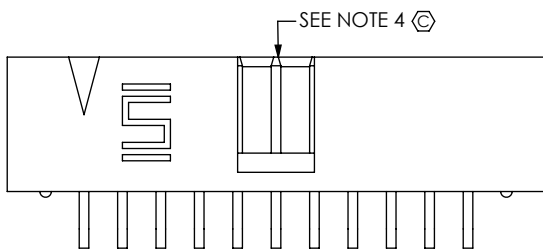
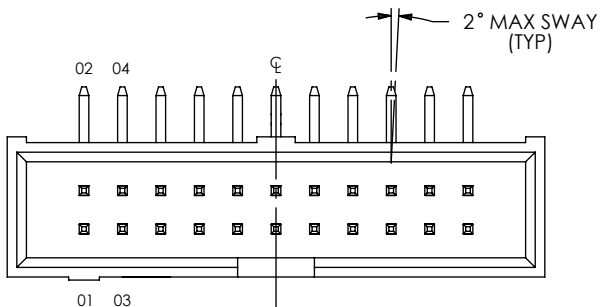
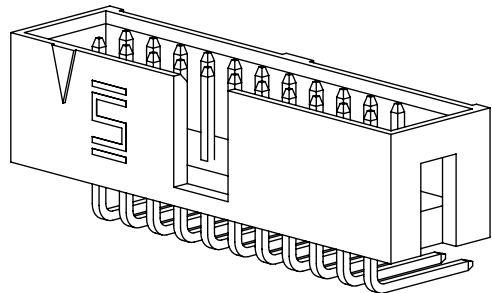

.035±.010 [0.89±0.25]
(TYP)

⊙*.0080 [0.203]
(TYP)

LEAD STYLE	"B"	"C"	"D"	TERMINAL #1	TERMINAL #2
-04	.130[3.30]	.280[7.11]	.830[21.08]	T-1S6-15-XX-2	T-1S6-10-XX-2
-05	.230[5.84]	.380[9.65]	.930[23.62]	T-1S6-09-XX-2	T-1S6-11-XX-2

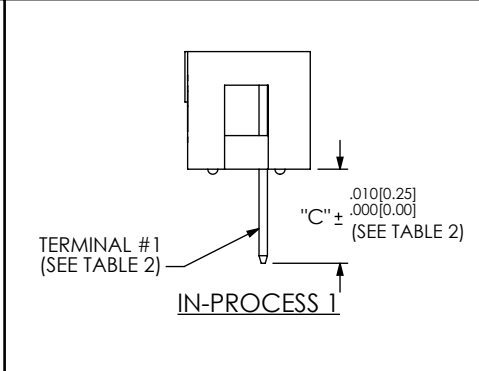
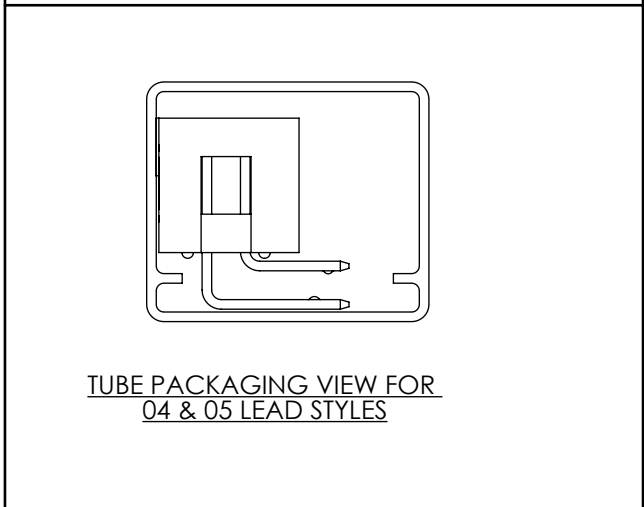
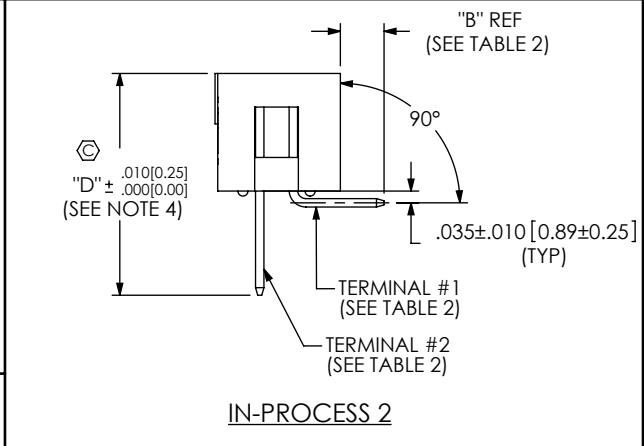
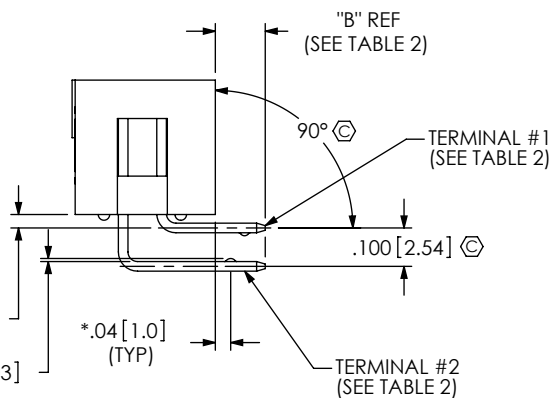

FIG 2
-RA & -LA OPTIONS
(HTST-111-04-XX-D-LA SHOWN)
(SAME AS FIG 1, UNLESS OTHERWISE STATED)
* DIMENSIONS APPLY WHEN USING -LA OPTION ONLY



Lead Style	Packaging	TUBES	PLUG
-01	Bulk	N/A	N/A
-02	Bulk	N/A	N/A
-03	Bulk	N/A	N/A
-04	Tube	PT-1-24-12T-109	TP-28
-05	Tube	PT-1-24-12T-109	TP-28

PROPRIETARY NOTE
THIS DOCUMENT CONTAINS INFORMATION CONFIDENTIAL AND PROPRIETARY TO SAMTEC, INC. AND SHALL NOT BE REPRODUCED OR TRANSFERRED TO OTHER DOCUMENTS OR DISCLOSED TO OTHERS OR USED FOR ANY PURPOSE OTHER THAN THAT WHICH IT WAS OBTAINED WITHOUT THE EXPRESSED WRITTEN CONSENT OF SAMTEC, INC.

DO NOT SCALE DRAWING
SHEET SCALE: 2:1

samtec
520 PARK EAST BLVD, NEW ALBANY, IN 47150
PHONE: 812-944-6733 FAX: 812-948-5047
e-Mail: info@SAMTEC.com code: 55322

DESCRIPTION:
HIGH TEMP TOP SHROUD TERMINAL STRIP
DWG. NO.
HTST-1XX-XX-XX-D-XX-XX
BY: BRATCHER 01/16/04 SHEET 2 OF 2