



Chipsmall Limited consists of a professional team with an average of over 10 year of expertise in the distribution of electronic components. Based in Hongkong, we have already established firm and mutual-benefit business relationships with customers from,Europe,America and south Asia,supplying obsolete and hard-to-find components to meet their specific needs.

With the principle of "Quality Parts,Customers Priority,Honest Operation,and Considerate Service",our business mainly focus on the distribution of electronic components. Line cards we deal with include Microchip,ALPS,ROHM,Xilinx,Pulse,ON,Everlight and Freescale. Main products comprise IC,Modules,Potentiometer,IC Socket,Relay,Connector.Our parts cover such applications as commercial,industrial, and automotives areas.

We are looking forward to setting up business relationship with you and hope to provide you with the best service and solution. Let us make a better world for our industry!



Contact us

Tel: +86-755-8981 8866 Fax: +86-755-8427 6832

Email & Skype: info@chipsmall.com Web: www.chipsmall.com

Address: A1208, Overseas Decoration Building, #122 Zhenhua RD., Futian, Shenzhen, China



40-Channel Symmetric Row Driver

Features

- ▶ HVCMOS® technology
- ▶ Symmetric row drive (reduces latent imaging in ACTFEL displays)
- ▶ Output voltage up to +240V
- ▶ Low power level shifting
- ▶ Source/sink current minimum 70mA
- ▶ Shift register speed 3.0MHz
- ▶ Pin-programmable shift direction (DIR, SHIFT)

General Description

The HV7224 is a low-voltage serial to high-voltage parallel converter with push-pull outputs. It is especially suitable for use as a symmetric row driver in AC thin-film electroluminescent (ACTFEL) displays.

When the data reset pin ($DR_{IO}A/DR_{IO}B$) is at logic high, it will reset all the outputs of the internal shift register to zero. At the same time, the output of the shift register will start shifting a logic high from the least significant bit to the most significant bit. The $DR_{IO}A/DR_{IO}B$ can be triggered at any time. The DIR and SHIFT pins control the direction of data shift through the device. When DIR is at logic high, $DR_{IO}A$ is the input and $DR_{IO}B$ is the output. When DIR is grounded, $DR_{IO}B$ is the input and the $DR_{IO}A$ is the output. See the Output Sequence Operation Table for output sequence. The \overline{POL} and \overline{OE} pins perform the polarity select and output enable function respectively. Data is loaded on the low to high transition of the clock. A logic high will cause the output to swing to V_{PP} if \overline{POL} is high, or to GND if \overline{POL} is low. All outputs will be in High-Z state if OE is at logic high. Data output buffers are provided for cascading devices.

Functional Block Diagram

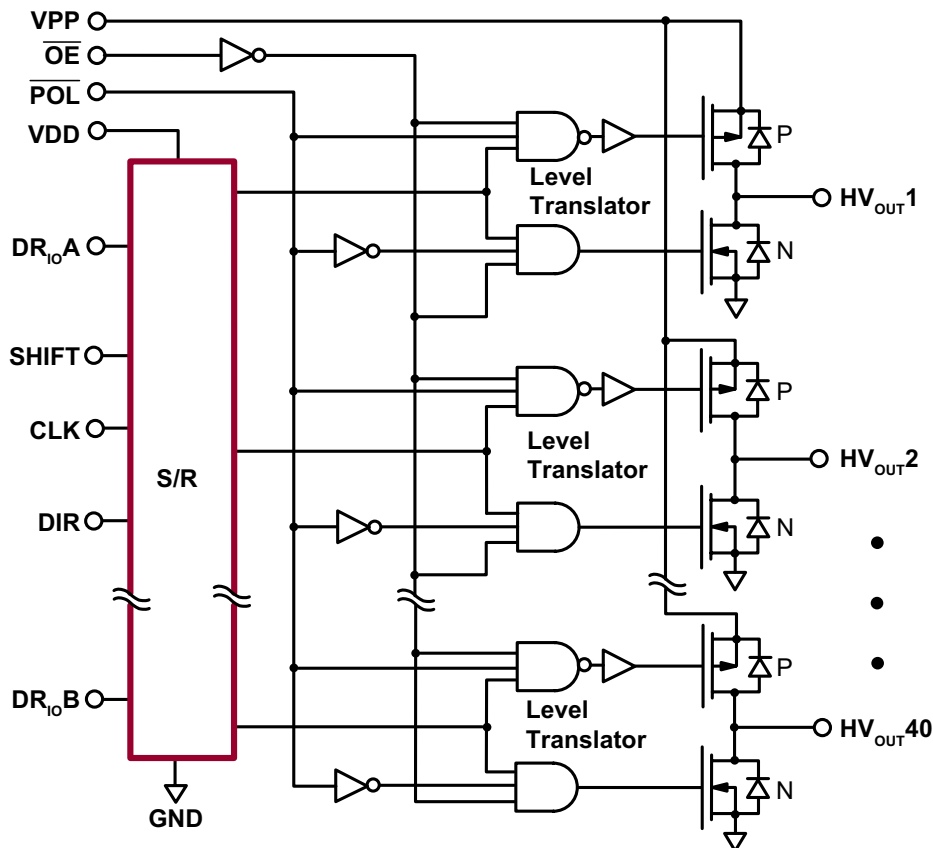

Ordering Information

Part Number	Package	Packing
HV7224PG-G	64-Lead PQFP	66/Tray

-G denotes a lead (Pb)-free / RoHS compliant package

Absolute Maximum Ratings

Parameter	Value
Supply voltage, V_{DD}	-0.5V to +7.0V
Supply voltage, V_{PP}	-0.5V to +260V
Logic input levels	-0.5V to $V_{DD} + 0.5V$
Continuous total power dissipation ¹	1200mW
Operating temperature range	-40°C to +85°C
Storage temperature range	-65°C to +150°C

Absolute Maximum Ratings are those values beyond which damage to the device may occur. Functional operation under these conditions is not implied. Continuous operation of the device at the absolute rating level may affect device reliability. All voltages are referenced to device ground.

Note:

- For operation above 25°C ambient derate linearly to maximum operating temperature at 20mW/°C.

Pin Configuration

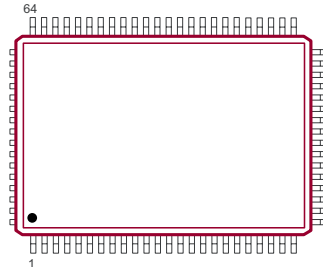

64-Lead PQFP (3-sided)
(top view)

Product Marking



Top Marking
 L = Lot Number
 YY = Year Sealed
 WW = Week Sealed
 C = Country of Origin
 A = Assembler ID
 — = "Green" Packaging

Package may or may not include the following marks: Si or

64-Lead PQFP (3-sided)

Typical Thermal Resistance

Package	θ_{ja}
44-Lead PLCC	37°C/W

Recommended Operating Conditions

Sym	Parameter	Min	Max	Units
V_{DD}	Logic supply voltage	4.5	5.5	V
V_{PP}	High voltage supply ¹	0	240	V
V_{IH}	High-level input voltage	0.7 V_{DD}	V_{DD}	V
V_{IL}	Low-level input voltage	0	0.2 V_{DD}	V
f_{CLK}	Clock frequency	-	3.0	MHz
T_A	Operating free-air temperature	-40	+85	°C
I_O	High voltage output current	-	±70	mA
I_{OD}	Allowable pulsed current through output diode	-	±300	mA

Note:

- Output will not switch at $V_{PP} = 0V$.

Power-up sequence should be the following:

- Connect ground.
- Apply V_{DD} .
- Set all inputs (Data, CLK, Enable, etc.) to a known state.
- Apply V_{PP} .

The V_{PP} should not drop below V_{DD} or float during operation.

Power-down sequence should be the reverse of the above.

DC Electrical Characteristics

(over recommended operating conditions of $V_{DD} = 5.0V$, $V_{PP} = 240V$, and $T_A = 25^\circ C$ unless noted)

Sym	Parameter	Min	Max	Units	Conditions	
I_{DD}	V_{DD} supply current	-	10	mA	$f_{CLK} = 3.0MHz$, $V_{DD} = 5.5V$	
I_{PP}	V_{PP} supply current	-	2.0	mA	All outputs low or High-Z	
		-	4.0	mA	One output high ¹	
I_{DDQ}	Quiescent V_{DD} supply current	-	100	μA	All $V_{IN} = GND$ or V_{DD}	
V_{OH}	High-level output	HV _{OUT}	190	-	V	$I_O = -70mA$
		DATA OUT	4.5	-	V	$I_O = -100\mu A$
V_{OL}	Low-level output	HV _{OUT}	-	50	V	$I_O = +70mA$
		DATA OUT	-	0.5	V	$I_O = +100\mu A$
I_{IH}	High-level logic input current	-	1.0	μA	$V_{IH} = V_{DD}$	
I_{IL}	Low-level logic input current	-	-1.0	μA	$V_{IL} = 0V$	
I_{SAT}	HV _{OUT} saturation current	P-channel	-80	-	mA	---
		N-channel	75	-	mA	---

Note:

1. Only one output can be turned on at a time.

AC Electrical Characteristics

($V_{DD} = 5.0V$ and $T_A = 25^\circ C$)

Sym	Parameter	Min	Max	Units	Conditions
f_{CLK}	Clock frequency	-	3.0	MHz	Per register, $C_L = 15pF$
t_{WH} , t_{WL}	Clock width high or low	150	-	ns	---
t_{SUD}	Data set-up time before clock rises	50	-	ns	---
t_{HD}	Data hold time after clock rises	50	-	ns	---
t_{SUC}	HV _{OUT} delay from clock rises (Hi-Z to H or L)	-	1.0	μs	$C_L = 330pF // R_L = 10k\Omega$
t_{SUE}	HV _{OUT} delay from Output Enable falls	-	600	ns	$C_L = 330pF // R_L = 10k\Omega$
t_{HC}	HV _{OUT} delay from clock rises (H or L to Hi-Z)	-	2.0	μs	$C_L = 330pF // R_L = 10k\Omega$
t_{HE}	HV _{OUT} delay from Output Enable rises	-	600	ns	$C_L = 330pF // R_L = 10k\Omega$
t_{DHL}	Delay time clock to data output falls*	-	250	ns	$C_L = 15pF$
t_{DLH}	Delay time clock to data output rises*	-	250	ns	$C_L = 15pF$
t_{ONF}	HV _{OUT} fall time	-	2.0	μs	$C_L = 330pF // R_L = 10k\Omega$
t_{ONR}	HV _{OUT} rise time	-	2.0	μs	$C_L = 330pF // R_L = 10k\Omega$
t_{POW}	POL pulse width	3.0	-	μs	---
t_{OEW}	Output Enable pulse width	3.0	-	μs	---
SR	Slew rate, V_{PP}	-	45	V/ μs	One active output driving 4.7nF load

Note:

* The delay is measured from the trailing edge of the clock but the data is triggered by the rising edge of the clock. There is an internal delay for the data output which is equal to t_{WH} .

Input and Output Equivalent Circuits

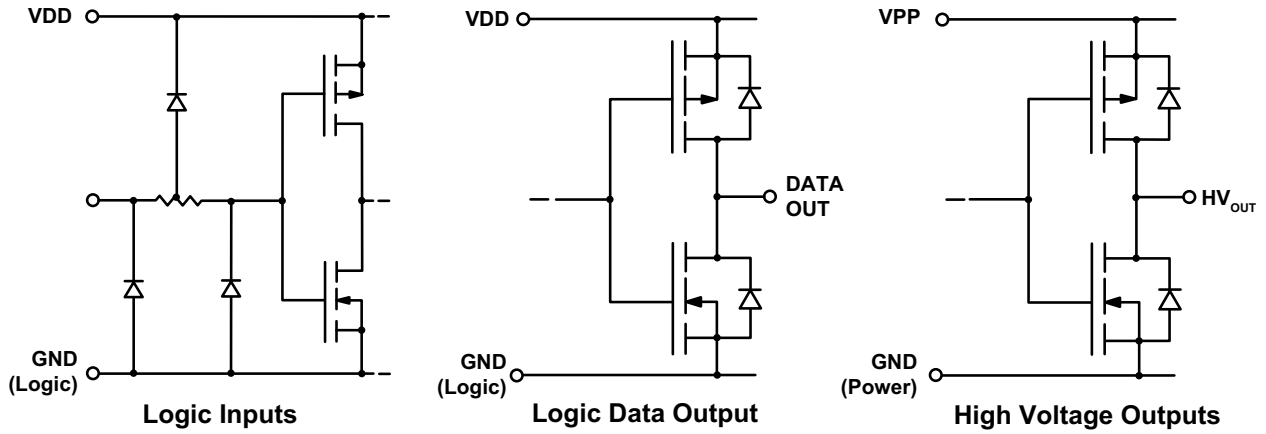

Switching Waveforms

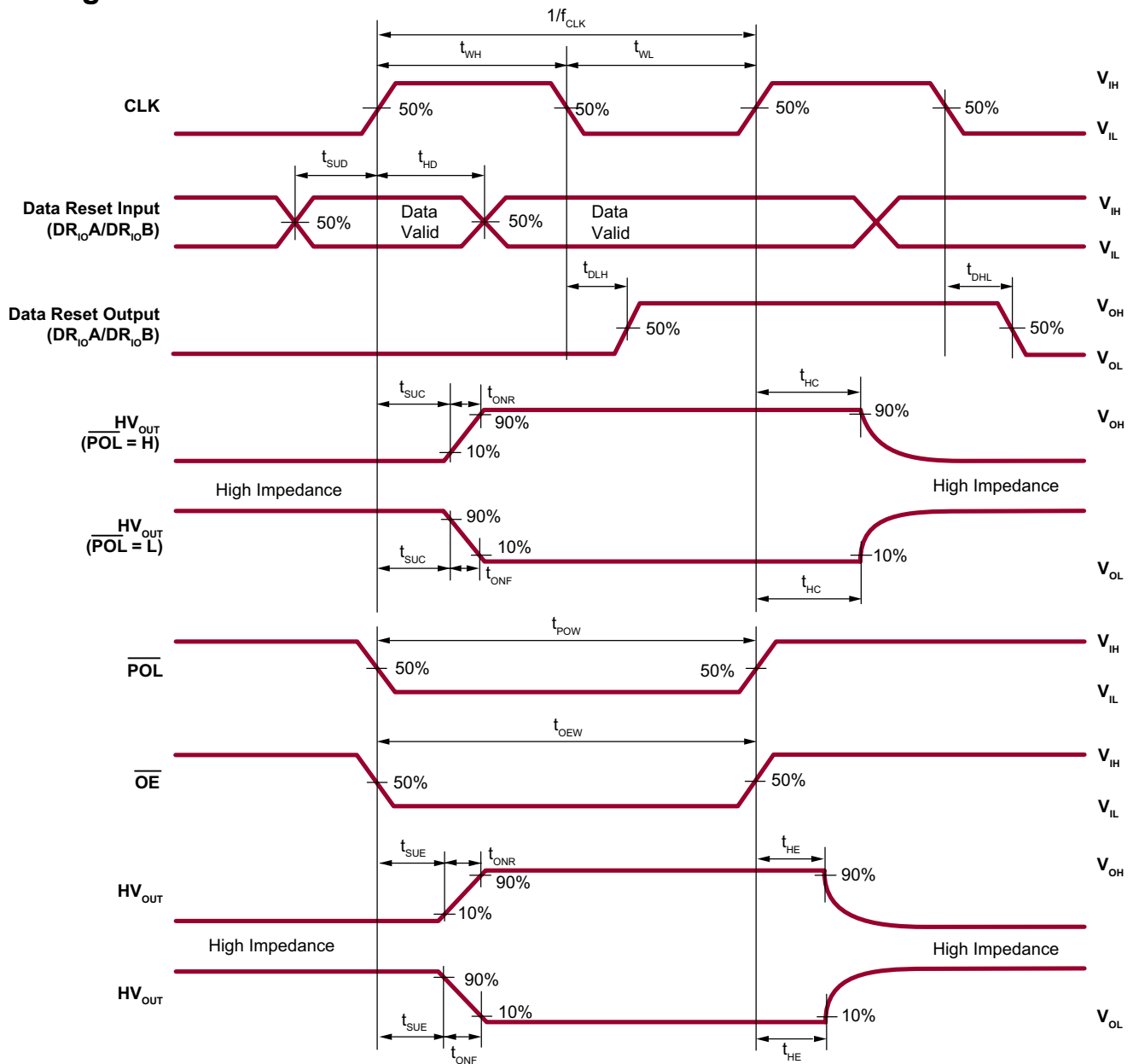





Function Table

I/O Relations	Inputs					HV Outputs
	CLK	DIR	S/R DATA	$\overline{\text{POL}}$	$\overline{\text{OE}}$	
O/P HIGH	X	X	H	H	L	H
O/P OFF	X	X	L	X	L	HIGH-Z
O/P LOW	X	X	H	L	L	L
O/P OFF	X	X	X	X	H	All O/P HIGH-Z

Notes:

H = logic high level, L = logic low level, X = irrelevant
 Data input (DR_{IO}) loaded on the low-to-high transition of the clock.
 Only one active output can be set at a time.

Output Sequence Operation Table

DIR	SHIFT	Data Reset In	Data Reset Out	HV _{OUT} # Sequence	Direction*
L	L	$DR_{IO}B$	$DR_{IO}A^1$	40 → 1	
H	L	$DR_{IO}A$	$DR_{IO}B^2$	1 → 40	
L	H	$DR_{IO}B$	$DR_{IO}A^1$	20 → 1 → 40 → 21	
H	H	$DR_{IO}A$	$DR_{IO}B^2$	21 → 40 → 1 → 20	

Notes:

- * Reference to package outline or chip layout drawing.
 1. $DR_{IO}A$ is $DR_{IO}B$ delayed by 40 clock pulses.
 2. $DR_{IO}B$ is $DR_{IO}A$ delayed by 40 clock pulses.

Pin Description - 64-Lead PQFP (3-sided) (PG) Option A

Pin #	Function	Pin #	Function	Pin #	Function	Pin #	Function
1	HV _{OUT} 1/40	17	HV _{OUT} 17/24	33	N/C	49	HV _{OUT} 25/16
2	HV _{OUT} 2/39	18	HV _{OUT} 18/23	34	DR _{IO} B	50	HV _{OUT} 26/15
3	HV _{OUT} 3/38	19	HV _{OUT} 19/22	35	\overline{OE}	51	HV _{OUT} 27/14
4	HV _{OUT} 4/37	20	HV _{OUT} 20/21	36	N/C	52	HV _{OUT} 28/13
5	HV _{OUT} 5/36	21	VPP	37	\overline{POL}	53	HV _{OUT} 29/12
6	HV _{OUT} 6/35	22	N/C	38	N/C	54	HV _{OUT} 30/11
7	HV _{OUT} 7/34	23	GND (Power)	39	VDD	55	HV _{OUT} 31/10
8	HV _{OUT} 8/33	24	GND (Logic)	40	N/C	56	HV _{OUT} 32/9
9	HV _{OUT} 9/32	25	DIR	41	GND (Logic)	57	HV _{OUT} 33/8
10	HV _{OUT} 10/31	26	VDD	42	GND (Power)	58	HV _{OUT} 34/7
11	HV _{OUT} 11/30	27	CLK	43	N/C	59	HV _{OUT} 35/6
12	HV _{OUT} 12/29	28	N/C	44	VPP	60	HV _{OUT} 36/5
13	HV _{OUT} 13/28	29	SHIFT	45	HV _{OUT} 21/20	61	HV _{OUT} 37/4
14	HV _{OUT} 14/27	30	N/C	46	HV _{OUT} 22/19	62	HV _{OUT} 38/3
15	HV _{OUT} 15/26	31	DR _{IO} A	47	HV _{OUT} 23/18	63	HV _{OUT} 39/2
16	HV _{OUT} 16/25	32	N/C	48	HV _{OUT} 24/17	64	HV _{OUT} 40/1

Note:

Pin designation for DIR H/L, Shift = L

Example: For DIR = H, pin 1 is HV_{OUT}1

For DIR = L, pin 1 is HV_{OUT}40

Pin Description - 64-Lead PQFP (3-sided) (PG) Option B

Pin #	Function	Pin #	Function	Pin #	Function	Pin #	Function
1	HV _{OUT} 20/21	17	HV _{OUT} 4/37	33	N/C	49	HV _{OUT} 36/5
2	HV _{OUT} 19/22	18	HV _{OUT} 3/38	34	DR _{IO} B	50	HV _{OUT} 35/6
3	HV _{OUT} 18/23	19	HV _{OUT} 2/39	35	\overline{OE}	51	HV _{OUT} 34/7
4	HV _{OUT} 17/24	20	HV _{OUT} 1/40	36	N/C	52	HV _{OUT} 33/8
5	HV _{OUT} 16/25	21	VPP	37	\overline{POL}	53	HV _{OUT} 32/9
6	HV _{OUT} 15/26	22	N/C	38	N/C	54	HV _{OUT} 31/10
7	HV _{OUT} 14/27	23	GND (Power)	39	VDD	55	HV _{OUT} 30/11
8	HV _{OUT} 13/28	24	GND (Logic)	40	N/C	56	HV _{OUT} 29/12
9	HV _{OUT} 12/29	25	DIR	41	GND (Logic)	57	HV _{OUT} 28/13
10	HV _{OUT} 11/30	26	VDD	42	GND (Power)	58	HV _{OUT} 27/14
11	HV _{OUT} 10/31	27	CLK	43	N/C	59	HV _{OUT} 26/15
12	HV _{OUT} 9/32	28	N/C	44	VPP	60	HV _{OUT} 25/16
13	HV _{OUT} 8/33	29	SHIFT	45	HV _{OUT} 40/1	61	HV _{OUT} 24/17
14	HV _{OUT} 7/34	30	N/C	46	HV _{OUT} 39/2	62	HV _{OUT} 23/18
15	HV _{OUT} 6/35	31	DR _{IO} A	47	HV _{OUT} 38/3	63	HV _{OUT} 22/19
16	HV _{OUT} 5/36	32	N/C	48	HV _{OUT} 37/4	64	HV _{OUT} 21/20

Note:

Pin designation for DIR H/L, Shift = H

Example: For DIR = H, pin 1 is HV_{OUT}20

For DIR = L, pin 1 is HV_{OUT}21

64-Lead PQFP (3-sided) Package Outline (PG)

20.00x14.00mm body, 3.40mm height (max), 0.80mm pitch, 3.90mm footprint

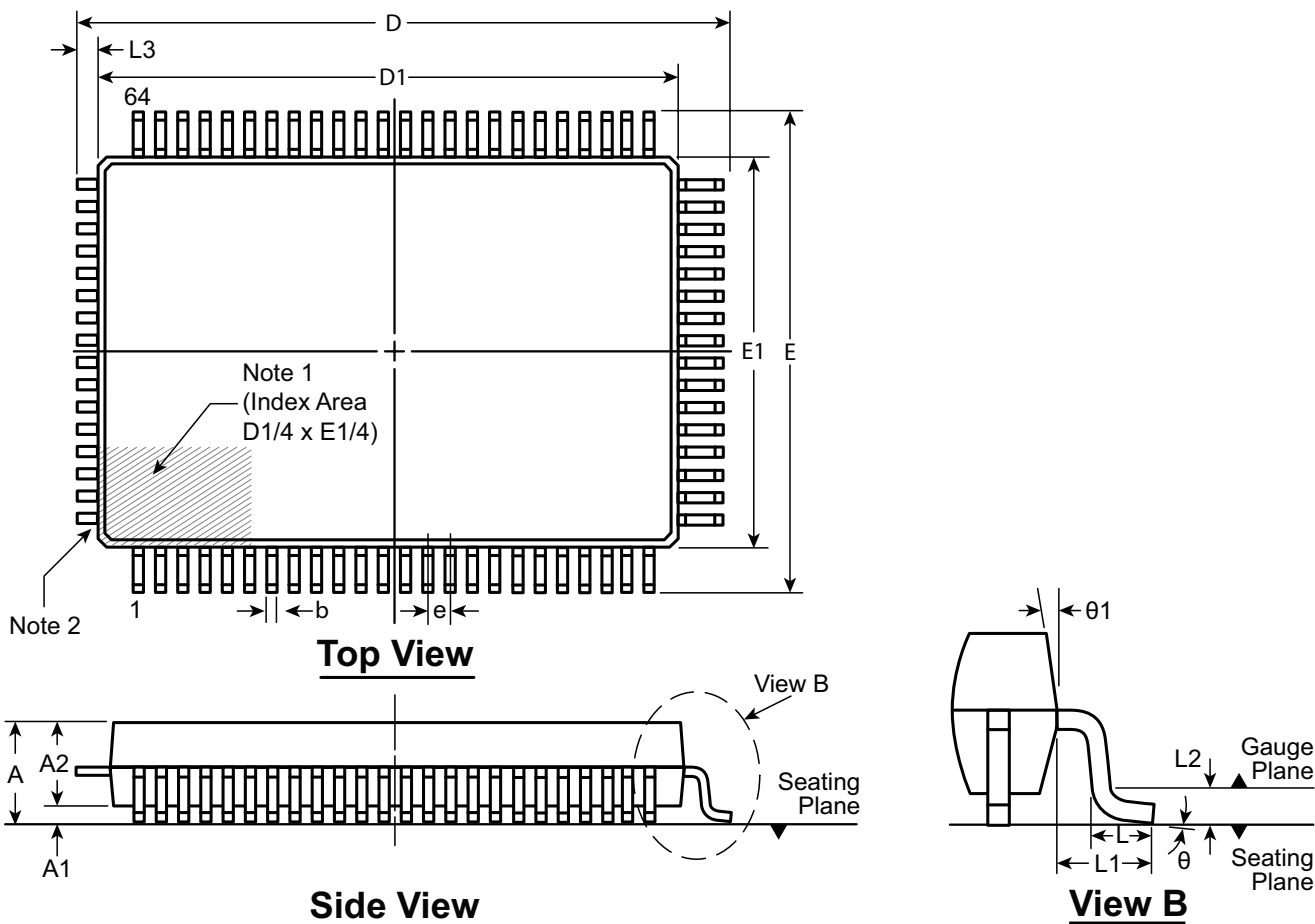

- Note:**
1. A Pin 1 identifier must be located in the index area indicated. The Pin 1 Identifier can be: a molded mark/identifier; an embedded metal marker; or a printed indicator.
 2. The leads on this side are trimmed.

Symbol	A	A1	A2	b	D	D1	E	E1	e	L	L1	L2	L3	θ	θ1	
Dimension (mm)	MIN	2.80	0.25	2.55	0.30	22.25	19.80	17.65	13.80	0.80 BSC	0.73	1.95 REF	0.25 BSC	0.55 REF	0°	5°
	NOM	-	-	2.80	-	22.50	20.00	17.90	14.00		0.88				3.5°	-
	MAX	3.40	0.50	3.05	0.45	22.75	20.20	18.15	14.20		1.03				7°	16°

Drawings not to scale.
Supertex Doc. #: DSPD-64PQFP, Version NR090608.

(The package drawing(s) in this data sheet may not reflect the most current specifications. For the latest package outline information go to <http://www.supertex.com/packaging.html>.)

Supertex inc. does not recommend the use of its products in life support applications, and will not knowingly sell them for use in such applications unless it receives an adequate "product liability indemnification insurance agreement." **Supertex inc.** does not assume responsibility for use of devices described, and limits its liability to the replacement of the devices determined defective due to workmanship. No responsibility is assumed for possible omissions and inaccuracies. Circuitry and specifications are subject to change without notice. For the latest product specifications refer to the **Supertex inc.** (website: <http://www.supertex.com>)