



Chipsmall Limited consists of a professional team with an average of over 10 year of expertise in the distribution of electronic components. Based in Hongkong, we have already established firm and mutual-benefit business relationships with customers from,Europe,America and south Asia,supplying obsolete and hard-to-find components to meet their specific needs.

With the principle of “Quality Parts,Customers Priority,Honest Operation,and Considerate Service”,our business mainly focus on the distribution of electronic components. Line cards we deal with include Microchip,ALPS,ROHM,Xilinx,Pulse,ON,Everlight and Freescale. Main products comprise IC,Modules,Potentiometer,IC Socket,Relay,Connector.Our parts cover such applications as commercial,industrial, and automotives areas.

We are looking forward to setting up business relationship with you and hope to provide you with the best service and solution. Let us make a better world for our industry!



Contact us

Tel: +86-755-8981 8866 Fax: +86-755-8427 6832

Email & Skype: info@chipsmall.com Web: www.chipsmall.com

Address: A1208, Overseas Decoration Building, #122 Zhenhua RD., Futian, Shenzhen, China



High Side Current Monitor 8.0 to 450V Voltage Gain of 5

Features

- ▶ Supply voltage 8V to 450V
- ▶ Voltage output device
- ▶ Typical gain 5.0±1%
- ▶ Max V_{SENSE} 500mV
- ▶ Fast rise and fall time, 700ns to 2.0µs
- ▶ Maximum quiescent current 50µA

Applications

- ▶ SMPS current monitor
- ▶ Battery current monitor
- ▶ Motor control

General Description

The HV7801 high side current monitor IC transfers a high-side current measurement voltage to its ground referenced output with a voltage gain of five. The measurement voltage typically originates at a current sense resistor which is located in a “high side” circuit, such as the positive supply line.

This monitor IC features a very wide input voltage range, high accuracy of transfer ratio, small size, low component count, low power consumption, ease of use, and low cost. Offline, battery, and portable applications can be served equally well due to the wide input voltage range and the low quiescent current.

Typical Application Circuit

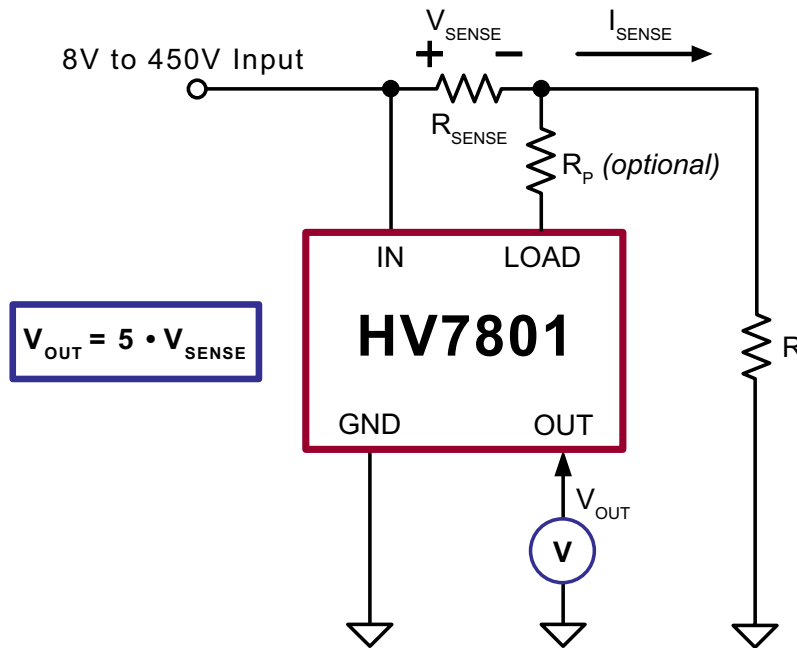

Ordering Information

Part Number	Package Option	Packing
HV7801K1-G	5-Lead SOT-23	2500/Reel

-G denotes a lead (Pb)-free / RoHS compliant package

Absolute Maximum Ratings

Parameter	Value
V_{IN}, V_{LOAD}	-0.5V to +460V
V_{OUT}	-0.5V to +10V
V_{SENSE}	-0.5V to +5.0V
I_{LOAD}	±10mA
Operating ambient temperature	-40°C to +85°C
Operating junction temperature	-40°C to +125°C
Storage temperature	-65°C to +150°C

Absolute maximum ratings are those values beyond which damage to the device may occur. Functional operation under these conditions is not implied. Continuous operation of the device at the absolute rating level may affect device reliability. All voltages are referenced to device ground.

Notes:

1. Referenced to GND
2. $V_{SENSE} = V_{IN} - V_{LOAD}$

Pin Configuration

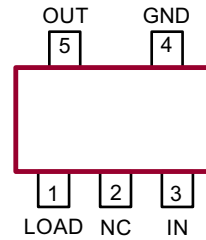

5-Lead SOT-23
(top view)

Product Marking



Y = Last Digit of Year Sealed
W = Code for Week Sealed
— = "Green" Packaging

Package may or may not include the following marks: Si or

5-Lead SOT-23

Typical Thermal Resistance

Package	θ_{ja}
5-Lead SOT-23	253°C/W

Note:

Thermal testboard per JEDEC JESD51-7

Electrical Characteristics ($T_A = 25^\circ\text{C}$ unless otherwise specified, $V_{IN} = 8\text{V}$ to 450V)

Sym	Parameter	Min	Typ	Max	Units	Conditions
-----	-----------	-----	-----	-----	-------	------------

Supply

V_{IN}	Supply voltage	8.0	-	450	V	* ---
I_Q	Quiescent supply current	-	-	50	μA	- $V_{IN} = 8\text{V}$ to 450V , $V_{SENSE} = 0\text{mV}$

Input and Output

R_{OUT}	OUT pin output resistance	-	16.5	-	kΩ	- ---	
V_{OUT}	Output voltage	0	-	65	mV	-	$V_{SENSE} = 0\text{mV}$
		420	-	580			$V_{SENSE} = 100\text{mV}$
		913	-	1087			$V_{SENSE} = 200\text{mV}$
		2395	-	2605			$V_{SENSE} = 500\text{mV}$

Dynamic Characteristics

t_{RISE}	Output rise time, 10% to 90%	-	0.7	-	μs	-	V_{SENSE} step 5.0mV to 500mV
		-	-	2.0			V_{SENSE} step 0mV to 500mV
t_{FALL}	Output fall time, 90% to 10%	-	0.7	2.0	μs	-	V_{SENSE} step 500mV to 0mV

* Values apply over the full temperature range.

Block Diagram

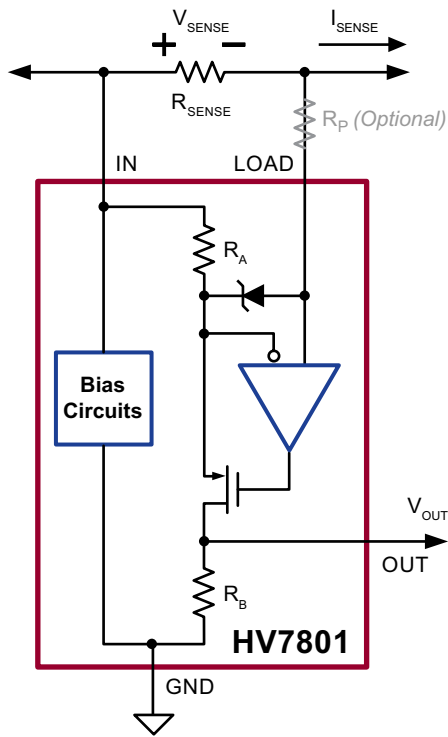

Application Information

General

The HV7801 high side current monitor IC features accurate current sensing, small size, low component count, low power consumption, exceptional input voltage range, ease of use and low cost.

Typical use is measurement of line or load current for purpose of overcurrent protection, metering and current regulation.

High side current sensing, as opposed to ground referenced or low side current sensing, is desirable or required when:

- ▶ The current to be measured does not flow in a circuit associated with ground.
- ▶ The measurement at ground level can lead to ambiguity due to changes in the grounding arrangement during field use.
- ▶ Introduction of a sense resistor in the system ground is undesirable due to issues with safety, EMI, or signal degradation caused by common impedance coupling.

Principle of Operation

The operational amplifier and MOSFET force the voltage across R_A to track V_{SENSE} within the limit of the offset voltage of the opamp, i.e. $V_{RA} = V_{SENSE}$.

The current through R_A returns to ground through R_B . R_A and R_B are integrated, exhibiting tight matching and excellent tracking. By design, R_B is five times larger than R_A . Consequently, V_{RB} is five times larger than V_{RA} , thus resulting in a voltage gain of 5.

OUT Pin Loading Effects

Note that the OUT pin has a typical output resistance of 16.5kΩ. Loading the output causes the voltage gain to drop and rise/fall time to increase.

For example, assuming output resistance is 16.5kΩ, the load resistance should exceed 16.5MΩ in order to limit the drop in gain to 1 part in 1000.

Again assuming output resistance is 16.5kΩ, capacitive loading of 6pF results in a response pole with a time constant of 100ns, not high enough to materially affect the output rise and fall time (about 700ns).

Sense Resistor Considerations

Limit the sense resistor voltage to 500mV during normal operating conditions. Limit the power dissipation in the sense resistor to suit the application; a high sense voltage benefits accuracy, but increases power dissipation.

Consider the use of Kelvin connections for applications where considerable voltage drops may occur in the PCB traces. A layout pattern which minimizes voltage across the sense lines is shown below.

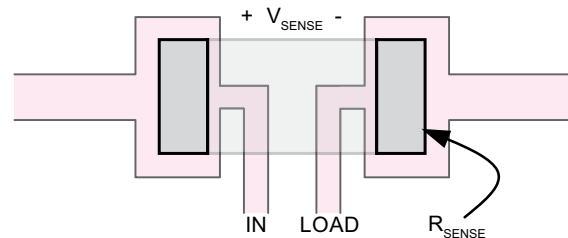

Choose a low inductance type sense resistor if preservation of bandwidth is important. The use of Kelvin connections helps by excluding the inductive voltage drop across the traces leading to the sense resistor. The inductive voltage drop may be substantial when operating at high frequencies. A trace or component inductance of just 10nH contributes an impedance of 6.2mΩ at 100kHz, which constitutes a 6% error when using a 100mΩ sense resistor.

Transient Protection

Add a protection resistor (R_p) in series with the LOAD pin if V_{SENSE} can exceed 5V in a positive sense or 600mV in a negative sense, whether in a steady state or in transient conditions.

A large V_{SENSE} may occur during system startup or shutdown due to the charging and discharging of bulk storage capacitors. V_{SENSE} may be large due to fault conditions, such as a short circuit condition, or a broken or missing sense resistor.

An internal 5.0V Zener diode with a current rating of 10mA protects the sense amplifier inputs. The block diagram shows the orientation of this diode. The Zener diode provides clamping at 5V for a positive V_{SENSE} and at 600mV for a negative V_{SENSE} .

Under worst case conditions, limit the Zener current to 10mA. A 100k Ω resistor limits the maximum Zener diode current to 4.5mA when V_{SENSE} is 450V, whether positive or negative. Note that the protection resistor may affect the bandwidth. The resistor forms a RC network with the trace and pin capacitance at the LOAD pin. A capacitance of 5.0pF results in a time constant of 500ns.

The protection resistor may cause an offset voltage due to bias current at the LOAD input. Under worst case bias current (1.0nA), a 100k Ω protection resistor could cause an offset of 100 μ V or 0.2% of full scale. Note that the bias current is nominally zero as the LOAD is a high impedance CMOS input.

Pin Description

Pin #	Pin Name	Description
1	LOAD	Sense amplifier input. High impedance input with Zener diode protection. Add an external protection resistor in series with LOAD if V_{SENSE} exceeds the range of -600mV to +5.0V.
2	NC	No connect. This pin must be left floating for proper operation.
3	IN	Sense amplifier input and supply.
4	GND	Supply return.
5	OUT	Output with a nominal output resistance of 16.5k Ω . Preservation of accuracy may require an external buffer amplifier to prevent excessive loading.

5-Lead SOT-23 Package Outline (K1)

2.90x1.60mm body, 1.45mm height (max), 0.95mm pitch

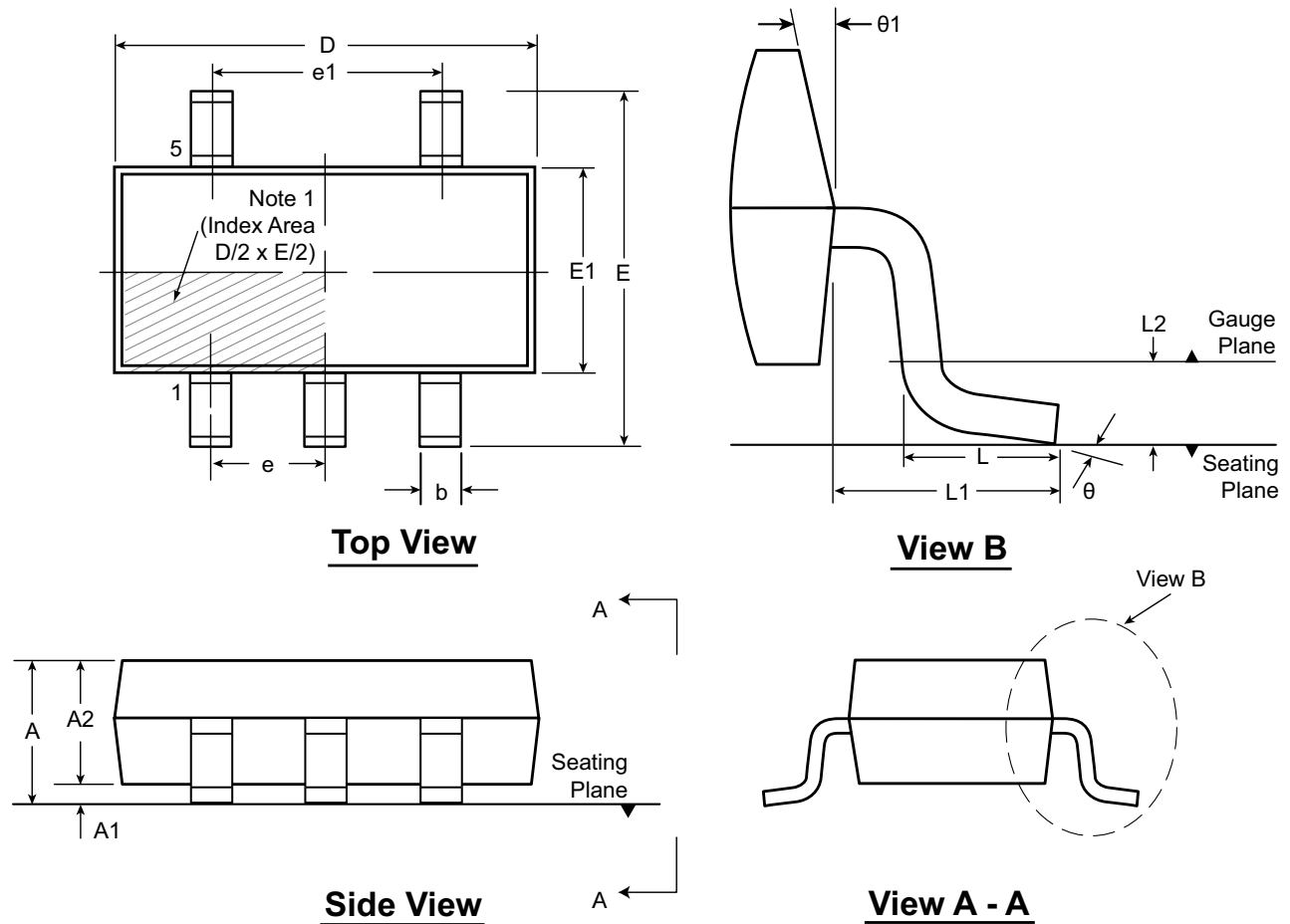

Note:
 1. A Pin 1 identifier must be located in the index area indicated. The Pin 1 identifier can be: a molded mark/identifier; an embedded metal marker; or a printed indicator.

Symbol	A	A1	A2	b	D	E	E1	e	e1	L	L1	L2	θ	θ_1	
Dimension (mm)	MIN	0.90*	0.00	0.90	0.30	2.75*	2.60*	1.45*	0.95 BSC	1.90 BSC	0.30	0.60 REF	0.25 BSC	0°	5°
	NOM	-	-	1.15	-	2.90	2.80	1.60			0.45			4°	10°
	MAX	1.45	0.15	1.30	0.50	3.05*	3.00*	1.75*			0.60			8°	15°

JEDEC Registration MO-178, Variation AA, Issue C, Feb. 2000.

* This dimension is not specified in the JEDEC drawing.

Drawings not to scale.

Supertex Doc. #: DSPD-5SOT23K1, Version A041309.

(The package drawing(s) in this data sheet may not reflect the most current specifications. For the latest package outline information go to <http://www.supertex.com/packaging.html>.)

Supertex inc. does not recommend the use of its products in life support applications, and will not knowingly sell them for use in such applications unless it receives an adequate "product liability indemnification insurance agreement." **Supertex inc.** does not assume responsibility for use of devices described, and limits its liability to the replacement of the devices determined defective due to workmanship. No responsibility is assumed for possible omissions and inaccuracies. Circuitry and specifications are subject to change without notice. For the latest product specifications refer to the **Supertex inc.** (website: <http://www.supertex.com>)