



Chipsmall Limited consists of a professional team with an average of over 10 year of expertise in the distribution of electronic components. Based in Hongkong, we have already established firm and mutual-benefit business relationships with customers from,Europe,America and south Asia,supplying obsolete and hard-to-find components to meet their specific needs.

With the principle of “Quality Parts,Customers Priority,Honest Operation,and Considerate Service”,our business mainly focus on the distribution of electronic components. Line cards we deal with include Microchip,ALPS,ROHM,Xilinx,Pulse,ON,Everlight and Freescale. Main products comprise IC,Modules,Potentiometer,IC Socket,Relay,Connector.Our parts cover such applications as commercial,industrial, and automotives areas.

We are looking forward to setting up business relationship with you and hope to provide you with the best service and solution. Let us make a better world for our industry!



## Contact us

Tel: +86-755-8981 8866 Fax: +86-755-8427 6832

Email & Skype: info@chipsmall.com Web: www.chipsmall.com

Address: A1208, Overseas Decoration Building, #122 Zhenhua RD., Futian, Shenzhen, China



# High Voltage EL Lamp Driver IC

## Features

- ▶ Processed with HVCMOS® technology
- ▶ 1.0 to 1.6V operating supply voltage
- ▶ DC to AC conversion
- ▶ Output load of typically up to 6.0nF
- ▶ Adjustable output lamp frequency
- ▶ Adjustable converter frequency
- ▶ Enable function

## Applications

- ▶ Pagers
- ▶ Portable transceivers
- ▶ Cellular phones
- ▶ Remote control units
- ▶ Calculators

## General Description

The Supertex HV825 is a high voltage driver designed for driving EL lamps typically up to 6.0nF. The input supply voltage range is from 1.0V to 1.6V. The device uses a single inductor and a minimum number of passive components. The typical output voltage that can be applied to the EL lamp is  $\pm 56V$ .

The HV825 can be enabled/disabled by connecting the  $R_{SW-Osc}$  resistor to VDD/GND.

The HV825 has two internal oscillators, a switching bipolar junction transistor (BJT), and a high voltage EL lamp driver. The frequency for the switching BJT is set by an external resistor connected between the RSW-Osc pin and the VDD supply pin. The EL lamp driver frequency is set by an external resistor connected between REL-Osc pin and the VDD pin. An external inductor is connected between the LX and VDD pins. A 0.01 to 0.1 $\mu$ F, 100V capacitor is connected between the CS pin and the GND pin. The EL lamp is connected between the VA pin and the VB pin.

The switching BJT charges the external inductor and discharges it into the 0.01 to 0.1 $\mu$ F, 100V capacitor at the CS pin. The voltage at the CS pin will start to increase. The outputs VA and VB are configured as an H-bridge and are switching in opposite states to achieve a peak-to-peak voltage of two times the  $V_{CS}$  voltage across the EL lamp.

**For additional information, see Application Notes AN-H33 and AN-H34.**

## Block Diagram

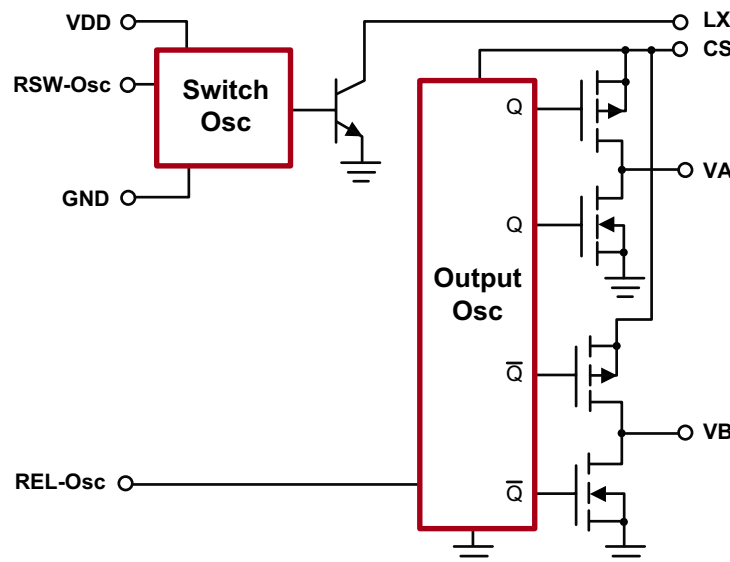

## Ordering Information

| Part Number | Package     | Packing   |
|-------------|-------------|-----------|
| HV833LG-G   | 8-Lead SOIC | 2500/Reel |
| HV833MG-G   | 8-Lead MSOP | 2500/Reel |

-G denotes a lead (Pb)-free / RoHS compliant package

## Absolute Maximum Ratings

| Parameter                   | Value           |
|-----------------------------|-----------------|
| Supply voltage, $V_{DD}$    | 0.5V to +2.5V   |
| Operating Temperature Range | -25°C to +85°C  |
| Storage Temperature Range   | -65°C to +150°C |
| MSOP-8 Power Dissipation    | 300mW           |
| SO-8 Power Dissipation      | 400mW           |

Absolute Maximum Ratings are those values beyond which damage to the device may occur. Functional operation under these conditions is not implied. Continuous operation of the device at the absolute rating level may affect device reliability. All voltages are referenced to device ground.

## Typical Thermal Resistance

| Package     | $\theta_{ja}$ |
|-------------|---------------|
| 8-Lead SOIC | 101°C/W       |
| 8-Lead MSOP | 216°C/W       |

## Electrical Characteristics

**DC Characteristics** (Over recommended operating conditions unless otherwise specified -  $T_A = 25^\circ\text{C}$ )

| Sym          | Parameter  | Min | Typ | Max | Units         | Conditions                                |
|--------------|--|-----|-----|-----|---------------|---|
| $R_{DS(ON)}$ | On-resistance of switching transistor                | -   | -   | 15  | $\Omega$      | $I = 50\text{mA}$                         |
| $I_{IN}$     | $V_{DD}$ supply current (including inductor current) | -   | 30  | 38  | mA            | $V_{DD} = 1.5\text{V}$ . See test circuit |
| $I_{DDQ}$    | Quiescent $V_{DD}$ supply current                    | -   | -   | 1.0 | $\mu\text{A}$ | $R_{SW-osc} = \text{GND}$                 |
| $V_{CS}$     | Output voltage on $V_{CS}$                           | 52  | 56  | 62  | V             | $V_{DD} = 1.5\text{V}$ . See test circuit |
| $V_{A-B}$    | Differential output voltage across lamp              | 104 | 112 | 124 | V             | $V_{DD} = 1.5\text{V}$ . See test circuit |
| $f_{EL}$     | $V_{A-B}$ output drive frequency                     | 400 | -   | -   | Hz            | $V_{DD} = 1.5\text{V}$ . See test circuit |
| $f_{SW}$     | Switching transistor frequency                       | -   | 30  | -   | KHz           | $V_{DD} = 1.5\text{V}$ . See test circuit |
| D            | Switching transistor duty cycle                      | -   | 88  | -   | %             | ---                                       |

### Recommended Operating Conditions

|          |                       |     |     |     |                  |     |
|----------|-----------------------|-----|-----|-----|------------------|-----|
| $V_{DD}$ | Supply voltage        | 1.0 | -   | 1.6 | V                | --- |
| $C_L$    | Load Capacitance      | 0   | 6.0 | -   | nF               | --- |
| $T_A$    | Operating temperature | -25 | -   | +85 | $^\circ\text{C}$ | --- |

### Enable/Disable Table

|          |   |                |   |          |   |                              |
|----------|---|----------------|---|----------|---|------------------------------|
| $V_{IL}$ | Low level input voltage to $R_{SW-osc}$ resistor  | 0              | - | 0.2      | V | $V_{DD} = 1.0 - 1.6\text{V}$ |
| $V_{IH}$ | High level input voltage to $R_{SW-osc}$ resistor | $V_{DD} - 0.5$ | - | $V_{DD}$ | V | $V_{DD} = 1.0 - 1.6\text{V}$ |

## Pin Configuration

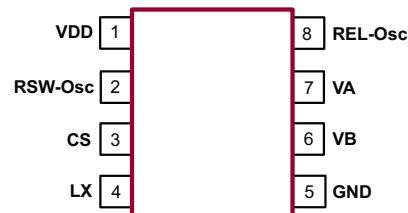

8-Lead SOIC / 8-Lead MSOP

## Product Marking



Y = Last Digit of Year Sealed  
 WW = Week Sealed  
 L = Lot Number  
 — = "Green" Packaging

Package may or may not include the following marks: Si or

### 8-Lead SOIC

Top Marking



L = Lot Number  
 YY = Year Sealed  
 WW = Week Sealed  
 — = "Green" Packaging

Bottom Marking



Package may or may not include the following marks: Si or

### 8-Lead MSOP

## Test Circuit

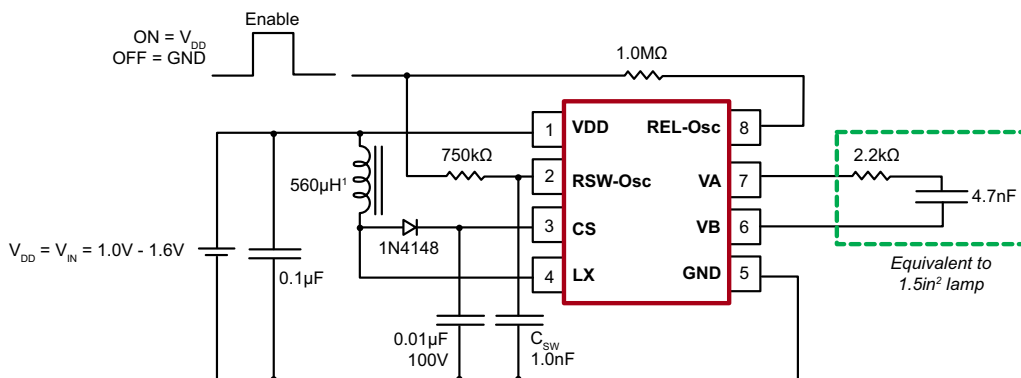

For additional information, see Application Notes AN-H33 and AN-H34.

## Typical Performance

| Lamp Size          | V <sub>IN</sub> | I <sub>DD</sub> | V <sub>CS</sub> | f <sub>EL</sub> | Brightness |
|--------------------|-----------------|-----------------|-----------------|-----------------|------------|
| 1.5in <sup>2</sup> | 1.5V            | 30mA            | 56V             | 450Hz           | 3.65ft-lm  |

### Notes:

- Murata part # LQH4N561K04 (Max DC resistance = 14.5Ω)

## External Component Description

| External Component           | Selection Guide Line  |
|------------------------------|---|
| Diode                        | Fast reverse recovery, 1N4148 or equivalent.  |
| C <sub>S</sub> Capacitor     | 0.01 to 0.1μF, 100V capacitor to GND is used to store the energy transferred from the inductor.   |
| R <sub>EL-Osc</sub> Resistor | <p>The lamp frequency is controlled via the R<sub>EL-Osc</sub>. The lamp frequency increases as the R<sub>EL-Osc</sub> decreases. As the lamp frequency increases, the amount of current drawn from the battery will increase and the output voltage V<sub>CS</sub> will decrease. This is because the lamp will draw more current from V<sub>CS</sub> when driven at higher frequencies.</p> <p>In general, as the lamp size increases, a larger R<sub>EL-Osc</sub> is recommended to provide higher V<sub>CS</sub>. However, the color of the lamp is dependent upon its frequency and the shade of the color will change slightly with different frequencies.</p>  |
| R <sub>SW-Osc</sub> Resistor | The switching frequency of the inductor is controlled via the R <sub>SW-Osc</sub> . The switching frequency increases as the R <sub>SW-Osc</sub> decreases. As the switching frequency increases, the amount of current drawn from the battery will decrease and the output voltage V <sub>CS</sub> will also decrease.   |
| L <sub>X</sub> Inductor      | <p>The inductor L<sub>X</sub> is used to boost up the low input voltage. When the internal switch is on, the inductor is being charged. When the internal switch is off, the charge in the inductor will be transferred to the high voltage capacitor C<sub>S</sub>. The energy stored in the capacitor is connected to the internal H-bridge and therefore to the lamp. In general smaller value inductors, which can handle more current, are more suitable to drive larger size lamps. As the inductor value decreases, the switching frequency of the inductor (controlled by R<sub>SW-Osc</sub>) should be increased to avoid saturation.</p> <p>The test circuit uses a Murata (LQH4N561) 560μH inductor. Using different inductor values or inductors from different manufacturers will affect the performance.</p> <p>As the inductor value decreases, smaller R<sub>SW-Osc</sub> values should be used. This will prevent inductor saturation. An inductor with the same inductance value, (560μH), but lower series resistance, will charge faster.</p> <p>The R<sub>SW-Osc</sub> resistor value needs to be decreased to prevent inductor saturation and high current consumption.</p> |
| C <sub>SW</sub> Capacitor    | A 1nF capacitor is recommended from the RSW-Osc pin to GND. This capacitor is used to shunt any switching noise that may couple into the RSW-Osc pin. A C <sub>SW</sub> larger than 1.0nF is not recommended.   |

# 8-Lead SOIC (Narrow Body) Package Outline (LG)

4.90x3.90mm body, 1.75mm height (max), 1.27mm pitch

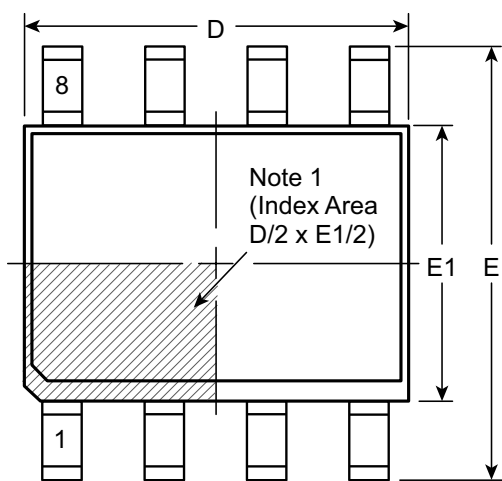

**Top View**

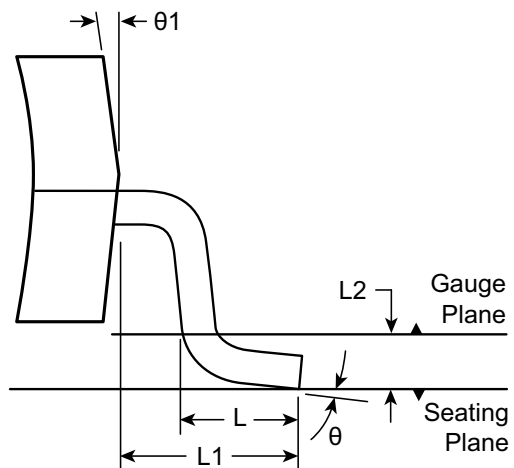

**View B**

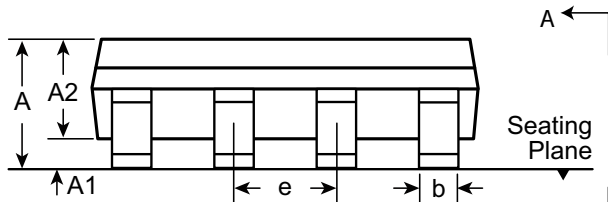

**Side View**

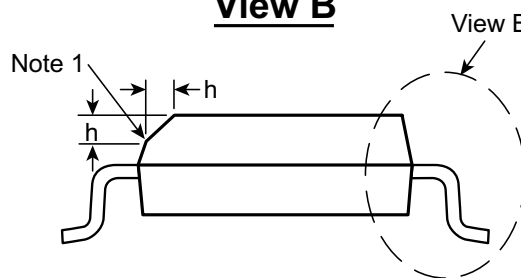

**View A-A**

**Note:**  
 1. This chamfer feature is optional. A Pin 1 identifier must be located in the index area indicated. The Pin 1 identifier can be: a molded mark/identifier; an embedded metal marker; or a printed indicator.

| Symbol         | A   | A1    | A2   | b     | D    | E     | E1    | e     | h        | L    | L1   | L2       | θ        | θ1 |     |
|----------------|-----|-------|------|-------|------|-------|-------|-------|----------|------|------|----------|----------|----|-----|
| Dimension (mm) | MIN | 1.35* | 0.10 | 1.25  | 0.31 | 4.80* | 5.80* | 3.80* | 1.27 BSC | 0.25 | 0.40 | 1.04 REF | 0.25 BSC | 0° | 5°  |
|                | NOM | -     | -    | -     | -    | 4.90  | 6.00  | 3.90  |          | -    | -    |          |          | -  | -   |
|                | MAX | 1.75  | 0.25 | 1.65* | 0.51 | 5.00* | 6.20* | 4.00* |          | 0.50 | 1.27 |          |          | 8° | 15° |

JEDEC Registration MS-012, Variation AA, Issue E, Sept. 2005.

\* This dimension is not specified in the JEDEC drawing.

Drawings are not to scale.

Supertex Doc. #: DSPD-8SOLGTG, Version 041309.

# 8-Lead MSOP Package Outline (MG)

3.00x3.00mm body, 1.10mm height (max), 0.65mm pitch

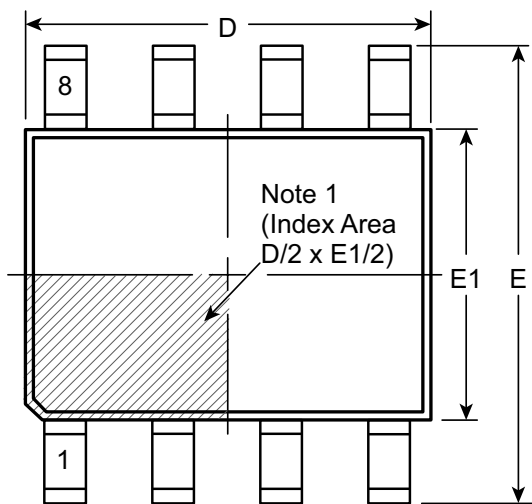

**Top View**

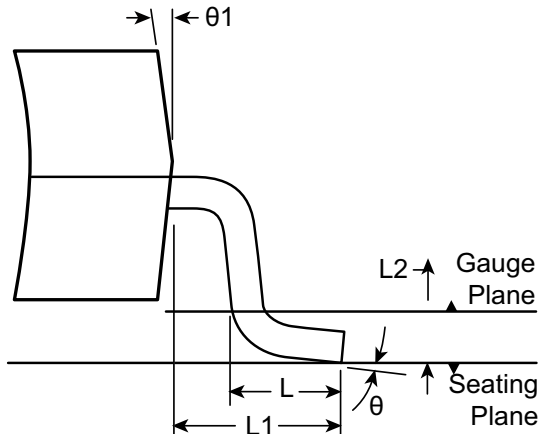

**View B**

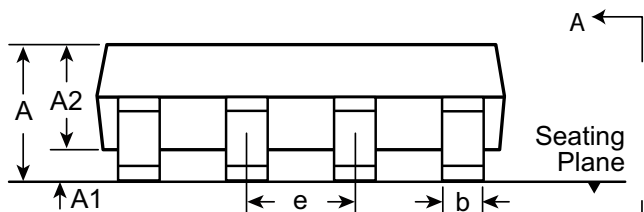

**Side View**

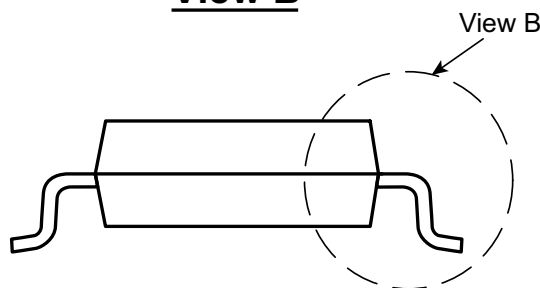

**View A-A**

**Note:**  
 1. A Pin 1 identifier must be located in the index area indicated. The Pin 1 identifier can be: a molded mark/identifier; an embedded metal marker; or a printed indicator.

| Symbol         | A   | A1    | A2   | b    | D    | E     | E1    | e     | L        | L1   | L2       | θ        | θ1 |     |
|----------------|-----|-------|------|------|------|-------|-------|-------|----------|------|----------|----------|----|-----|
| Dimension (mm) | MIN | 0.75* | 0.00 | 0.75 | 0.22 | 2.80* | 4.65* | 2.80* | 0.65 BSC | 0.40 | 0.95 REF | 0.25 BSC | 0° | 5°  |
|                | NOM | -     | -    | 0.85 | -    | 3.00  | 4.90  | 3.00  |          | 0.60 |          |          | -  | -   |
|                | MAX | 1.10  | 0.15 | 0.95 | 0.38 | 3.20* | 5.15* | 3.20* |          | 0.80 |          |          | 8° | 15° |

JEDEC Registration MO-187, Variation AA, Issue E, Dec. 2004.

\* This dimension is not specified in the JEDEC drawing.

**Drawings are not to scale.**

Supertex Doc. #: DSPD-8MSOPMG, Version I041309.

(The package drawing(s) in this data sheet may not reflect the most current specifications. For the latest package outline information go to <http://www.supertex.com/packaging.html>.)

**Supertex inc.** does not recommend the use of its products in life support applications, and will not knowingly sell them for use in such applications unless it receives an adequate "product liability indemnification insurance agreement." **Supertex inc.** does not assume responsibility for use of devices described, and limits its liability to the replacement of the devices determined defective due to workmanship. No responsibility is assumed for possible omissions and inaccuracies. Circuitry and specifications are subject to change without notice. For the latest product specifications refer to the **Supertex inc.** (website: <http://www.supertex.com>)