



Chipsmall Limited consists of a professional team with an average of over 10 year of expertise in the distribution of electronic components. Based in Hongkong, we have already established firm and mutual-benefit business relationships with customers from,Europe,America and south Asia,supplying obsolete and hard-to-find components to meet their specific needs.

With the principle of “Quality Parts,Customers Priority,Honest Operation,and Considerate Service”,our business mainly focus on the distribution of electronic components. Line cards we deal with include Microchip,ALPS,ROHM,Xilinx,Pulse,ON,Everlight and Freescale. Main products comprise IC,Modules,Potentiometer,IC Socket,Relay,Connector.Our parts cover such applications as commercial,industrial, and automotives areas.

We are looking forward to setting up business relationship with you and hope to provide you with the best service and solution. Let us make a better world for our industry!



Contact us

Tel: +86-755-8981 8866 Fax: +86-755-8427 6832

Email & Skype: info@chipsmall.com Web: www.chipsmall.com

Address: A1208, Overseas Decoration Building, #122 Zhenhua RD., Futian, Shenzhen, China



Universal High-Brightness LED Driver

Features

- Switch mode controller for single switch LED drivers
- Enhanced drop-in replacement to the HV9910B
- Open loop peak current controller
- Internal 15 to 450V linear regulator
- Constant frequency or constant off-time operation
- Linear and PWM dimming capability
- Requires few external components for operation
- Over-temperature protection

Applications

- DC/DC or AC/DC LED driver applications
- RGB back-lighting LED driver
- Back lighting of flat panel displays
- General purpose constant current source
- Signage and decorative LED lighting
- Chargers

Description

HV9910C is an open-loop, current-mode control, LED driver IC. This IC can be programmed to operate in either a constant frequency or constant off-time mode. It includes a 15 – 450V linear regulator which allows it to work with a wide range of input voltages without the need for an external low voltage supply. HV9910C includes a TTL-compatible, PWM-dimming input that can accept an external control signal with a duty ratio of 0 – 100% and a frequency of up to a few kilohertz. It also includes a 0 – 250mV linear-dimming input which can be used for linear dimming of the LED current. Unlike the HV9910B, the HV9910C is equipped with built-in thermal-shutdown protection.

HV9910C is ideally suited for buck LED drivers. Since the HV9910C operates in open-loop current mode control, the controller achieves good output current regulation without the need for any loop compensation. Also, being an open-loop controller, PWM-dimming response is limited only by the rate of rise of the inductor current, enabling a very fast rise and fall times of the LED current. HV9910C requires only three external components (apart from the power stage) to produce a controlled LED current. This makes HV9910C an ideal solution for low-cost LED drivers.

TO OUR VALUED CUSTOMERS

It is our intention to provide our valued customers with the best documentation possible to ensure successful use of your Microchip products. To this end, we will continue to improve our publications to better suit your needs. Our publications will be refined and enhanced as new volumes and updates are introduced.

If you have any questions or comments regarding this publication, please contact the Marketing Communications Department via E-mail at docerrors@microchip.com. We welcome your feedback.

Most Current Data Sheet

To obtain the most up-to-date version of this data sheet, please register at our Worldwide Web site at:

<http://www.microchip.com>

You can determine the version of a data sheet by examining its literature number found on the bottom outside corner of any page. The last character of the literature number is the version number, (e.g., DS30000000A is version A of document DS30000000).

Errata

An errata sheet, describing minor operational differences from the data sheet and recommended workarounds, may exist for current devices. As device/documentation issues become known to us, we will publish an errata sheet. The errata will specify the revision of silicon and revision of document to which it applies.

To determine if an errata sheet exists for a particular device, please check with one of the following:

- Microchip's Worldwide Web site; <http://www.microchip.com>
- Your local Microchip sales office (see last page)

When contacting a sales office, please specify which device, revision of silicon and data sheet (include literature number) you are using.

Customer Notification System

Register on our web site at www.microchip.com to receive the most current information on all of our products.

Pin Diagram

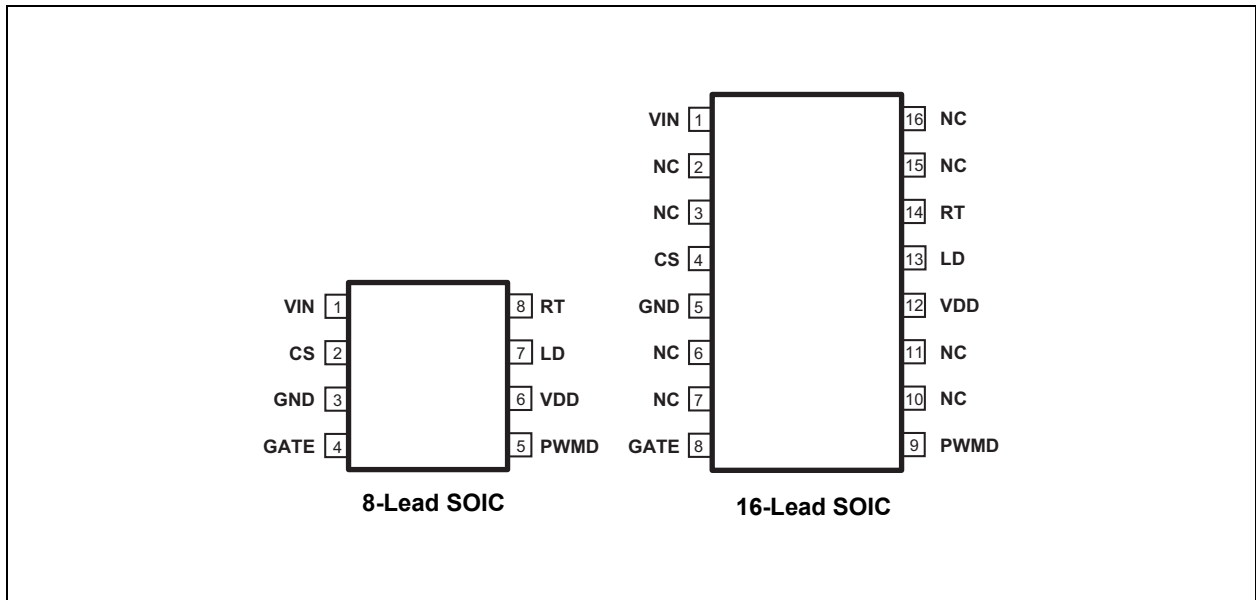

Typical Application Circuit

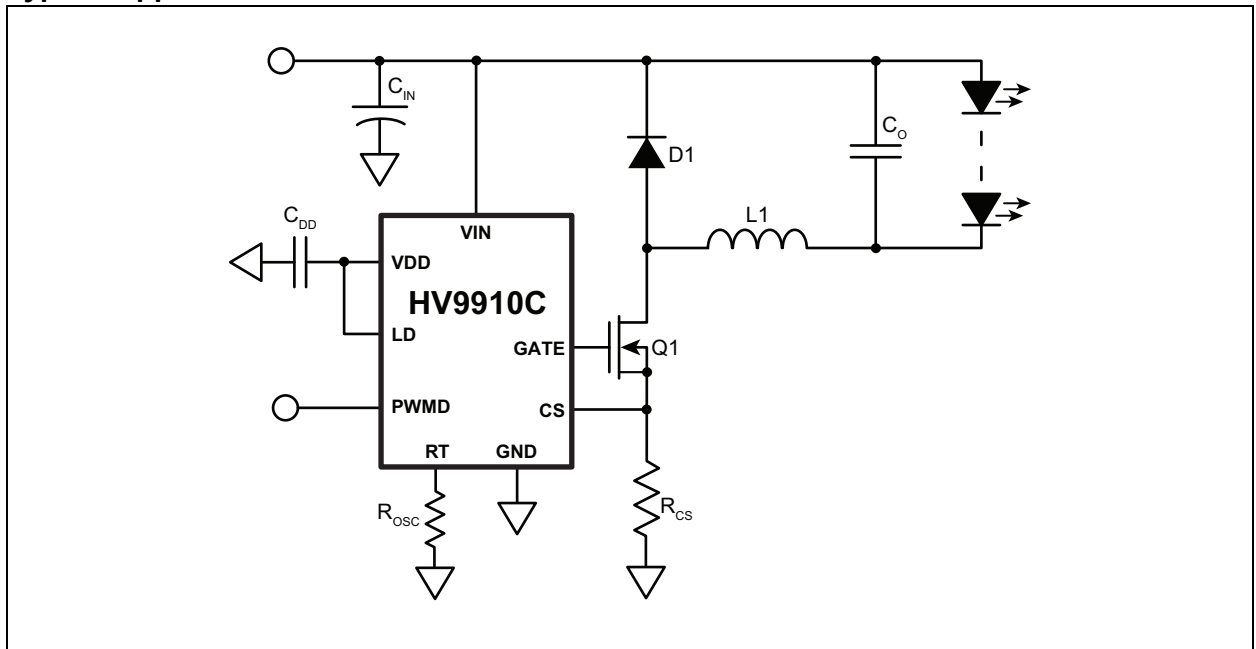

HV9910C

1.0 ELECTRICAL CHARACTERISTICS

ABSOLUTE MAXIMUM RATINGS

V_{IN} to GND	-0.5V to +470V
V_{DD} to GND.....	12V
CS, LD, PWM, GATE.....	-0.3V to ($V_{DD} + 0.3V$)
Junction temperature	-40°C to +125°C
Storage temperature	-65°C to +150°C
Continuous power dissipation ($T_A = +25^\circ\text{C}$)	
8-lead SOIC	650 mW
16-lead SOIC	1300 mW
8-lead SOIC with heat slug	1300 mW

Note: Stresses above those listed under “Absolute Maximum Ratings” may cause permanent damage to the device. This is a stress rating only and functional operation of the device at those or any other conditions, above those indicated in the operational listings of this specification, is not implied. Exposure to maximum rating conditions for extended periods may affect device reliability.

1.1 ELECTRICAL SPECIFICATIONS

TABLE 1-1: ELECTRICAL CHARACTERISTICS (SHEET 1 OF 2)¹

Symbol	Parameter	Note	Min	Typ	Max	Units	Conditions
Input							
V_{INDC}	Input DC supply voltage range ²	3	15	-	450	V	DC input voltage
$I_{IN(MAX)}$	Supply current	-	-	0.8	1.5	mA	Pin PWM to V_{DD} , no capacitance at GATE
I_{INSD}	Shut-down mode supply current	-	-	0.5	1.0	mA	Pin PWM to GND
Internal Regulator							
V_{DD}	Internally regulated voltage	-	7.25	7.50	7.75	V	$V_{IN} = 15V$, $I_{DD(ext)} = 0$, PWM = V_{DD} , 500pF at GATE; $R_{OSC} = 249k\Omega$
$\Delta V_{DD, \text{line}}$	Line regulation of V_{DD}	-	0	-	1.0	V	$V_{IN} = 15 - 450V$, $I_{DD(ext)} = 0$, PWM = V_{DD} , 500pF at GATE; $R_{OSC} = 249k\Omega$
$\Delta V_{DD, \text{load}}$	Load regulation of V_{DD}	-	0	-	0.1	V	$I_{DD(ext)} = 0 - 1.0mA$, PWM = V_{DD} , 500pF at GATE; $R_{OSC} = 249k\Omega$
UVLO	V_{DD} under voltage lockout threshold	3	6.45	6.70	6.95	V	V_{DD} rising
$\Delta UVLO$	V_{DD} under voltage lockout hysteresis	-	-	500	-	mV	V_{DD} falling
$I_{IN(MAX)}$	Maximum regulator current	4	5.0	-	-	mA	$V_{DD} = UVLO - \Delta UVLO$
PWM Dimming							
$V_{EN(lo)}$	PWM input low voltage	3	-	-	1.0	V	$V_{IN} = 15 - 450V$
$V_{EN(hi)}$	PWM input high voltage	3	2.4	-	-	V	$V_{IN} = 15 - 450V$
R_{EN}	Internal pull-down resistance at PWM	-	50	100	150	k Ω	$V_{PWM} = 5.0V$

TABLE 1-1: ELECTRICAL CHARACTERISTICS (CONTINUED) (SHEET 2 OF 2)¹

Symbol	Parameter	Note	Min	Typ	Max	Units	Conditions
Current Sense Comparator							
V _{CS}	Current sense pull-in threshold voltage	-	225	250	275	mV	-40°C < T _A < +125°C
V _{OFFSET}	Offset voltage for LD comparator	3	-12	-	+12	mV	
T _{BLANK}	Current sense blanking interval	-	150	215	280	ns	0 < T _A < +85°C, V _{LD} = V _{DD} , V _{CS} = V _{CS,TH} + 50mV after T _{BLANK}
		-	145	215	315		-40 < T _A < +125°C, V _{LD} = V _{DD} , V _{CS} = V _{CS,TH} + 50mV after T _{BLANK}
t _{DELAY}	Delay to output	-	-	80	150	ns	V _{IN} = 15V, V _{LD} = 0.15, V _{CS} = 0 to 0.22V after t _{BLANK}
Oscillator							
f _{OSC}	Oscillator frequency	-	20	25	30	kHz	R _{OSC} = 1.00MΩ
		-	80	100	120		R _{OSC} = 249kΩ
Gate Driver							
I _{SOURCE}	Maximum GATE sourcing current	-	0.165	-	-	A	V _{GATE} = 0V
I _{SINK}	Maximum GATE sinking current	-	0.165	-	-	A	V _{GATE} = V _{DD}
t _{RISE}	GATE output rise time	4	-	30	50	ns	C _{GATE} = 500pF
t _{FALL}	GATE output fall time	4	-	30	50	ns	C _{GATE} = 500pF
Over-Temperature Protection							
T _{SD}	Shut-down temperature	-	128	-	150	°C	
ΔT _{SD}	Hysteresis	-	10	-	30	°C	
I _{SD}	T _{SD} -mode V _{IN} current	-	-	-	350	μA	

- 1 Specifications are T_A = 25°C, V_{IN} = 15V unless otherwise noted.
- 2 Also limited by package-power dissipation limit; Whichever is lower.
- 3 Applies over the full operating ambient temperature range of -40°C < T_A < +125°C.
- 4 For design guidance only.

TABLE 1-2: THERMAL RESISTANCE

Package	θ _{ja}
8-Lead SOIC	101°C/W
16-Lead SOIC	83°C/W
8-Lead SOIC (with heat slug)	84°C/W

HV9910C

2.0 PIN DESCRIPTION

The descriptions of the pins are listed in [Table 2-1](#).

TABLE 2-1: PIN DESCRIPTION

Pin #		Function	Description
8-Lead SOIC	16-Lead SOIC		
1	1	VIN	Input of an 15 - 450V linear regulator.
2	4	CS	Current sense pin used to sense the FET current by means of an external sense resistor. When this pin exceeds the lower of either the internal 250mV or the voltage at the LD pin, the GATE output goes low.
3	5	GND	Ground return for all internal circuitry. Must be electrically connected to the power ground.
4	8	GATE	Output GATE driver for an external N-channel power MOSFET.
5	9	PWMD	TTL-compatible, PWM-dimming input of the IC. When this pin is pulled to GND or left open, the GATE driver is turned off. When the pin is pulled high, the GATE driver operates normally.
6	12	VDD	Power supply pin for all internal circuits. It must be bypassed with a low ESR capacitor to GND ($\geq 0.1\mu\text{F}$).
7	13	LD	Linear-dimming input and sets the current sense threshold as long as the voltage at the pin is less than 250mV (typ).
8	14	RT	Sets the oscillator frequency. When a resistor is connected between RT and GND, the HV9910C operates in constant frequency mode. When the resistor is connected between RT and GATE, the IC operates in constant off-time mode.
-	2, 3, 6, 7, 10, 11, 15, 16	NC	No connection

3.0 APPLICATION INFORMATION

HV9910C is optimized to drive buck LED drivers using open-loop, peak-current mode control. This method of control enables fairly accurate LED current control without the need for high side current sensing or the design of any closed loop controllers. The IC uses very few external components and enables both Linear and PWM-dimming of the LED current.

A resistor connected to the RT pin programs the frequency of operation (or the off-time). The oscillator produces pulses at regular intervals. These pulses set the SR flip-flop in the HV9910C which causes the GATE driver to turn on. The same pulses also start the blanking timer, which inhibits the reset input of the SR flip flop and prevents false turn-offs due to the turn-on spike. When the FET turns on, the current through the inductor starts ramping up. This current flows through the external sense resistor, R_{CS} , and produces a ramp voltage at the CS pin. The comparators are constantly comparing the CS pin voltage to both the voltage at the LD pin and the internal 250mV. Once the blanking timer is complete, the output of these comparators is allowed to reset the flip-flop. When the output of either one of the two comparators goes high, the flip-flop is reset and the GATE output goes low. The GATE goes low until the SR flip-flop is set by the oscillator. Assuming a 30% ripple in the inductor, the current sense resistor R_{CS} can be set using:

$$R_{CS} = \frac{0.25V(\text{or } V_{LD})}{1.15 \cdot I_{LED}}$$

Constant frequency peak current mode control has an inherent disadvantage – at duty cycles greater than 0.5, the control scheme goes into subharmonic oscillations. To prevent this, an artificial slope is typically added to the current sense waveform. This slope compensation scheme will affect the accuracy of the LED current in the present form. However, a constant off-time peak current control scheme does not have this problem and can easily operate at duty cycles greater than 0.5. This control scheme also gives inherent input voltage rejection, making the LED current almost insensitive to input voltage variations. However, this scheme leads to variable frequency operation and the frequency range depends greatly on the input and output voltage variation. Using HV9910C, it is easy to switch between the two modes of operation by changing one connection (see [Section 3.3 “Oscillator”](#)).

3.1 Input Voltage Regulator

HV9910C can be powered directly from its V_{IN} pin and can work from 15 - 450VDC at its V_{IN} pin. When a voltage is applied at the V_{IN} pin, HV9910C maintains a constant 7.5V at the V_{DD} pin. This voltage is used to power the IC and any external-resistor dividers needed

to control the IC. The V_{DD} pin must be bypassed by a low-ESR capacitor to provide a low impedance path for the high frequency current of the output GATE driver.

HV9910C can also be operated by supplying a voltage at the V_{DD} pin greater than the internally regulated voltage. This will turn off the internal linear regulator of the IC and the HV9910C will operate directly off the voltage supplied at the V_{DD} pin. This external voltage at the V_{DD} pin should not exceed 12V.

Although the V_{IN} pin of the HV9910C is rated up to 450V, the actual maximum voltage that can be applied is limited by the power dissipation in the IC. For example, if an 8-lead SOIC HV9910C (junction to ambient thermal resistance $R_{\theta j-a} = 101^{\circ}\text{C/W}$) draws about $I_{IN} = 2.0\text{mA}$ from the V_{IN} pin, and has a maximum allowable temperature rise of the junction temperature limited to $\Delta T = 75^{\circ}\text{C}$, the maximum voltage at the V_{IN} pin would be:

$$\begin{aligned} V_{IN(\text{MAX})} &= \frac{\Delta T}{R_{\theta j-a}} \cdot \frac{1}{I_{IN}} \\ &= \frac{75^{\circ}\text{C}}{101^{\circ}\text{C/W}} \cdot \frac{1}{2\text{mA}} \\ &= 371\text{V} \end{aligned}$$

In these cases, to operate HV9910C from higher input voltages, a Zener diode can be added in series with the V_{IN} pin to divert some of the power loss from HV9910C to the Zener diode. In the above example, using a 100V Zener diode will allow the circuit to easily work up to 450V.

Note: The Zener diode will increase the minimum input voltage required to turn on the HV9910C to 115V.

The input current drawn from the V_{IN} pin is a sum of the 1.5mA (maximum) current drawn by the internal circuit and the current drawn by the GATE driver. The GATE driver depends on the switching frequency and the GATE charge of the external FET.

$$I_{IN} = 1.5\text{mA} + Q_g \cdot f_s$$

In the above equation, f_s is the switching frequency and Q_g is the GATE charge of the external FET, which can be obtained from the data sheet of the FET.

3.2 Current Sense

The current sense input of HV9910C goes to the non-inverting inputs of two comparators. The inverting terminal of one comparator is tied to an internal 250mV reference, whereas the inverting terminal of the other comparator is connected to the LD pin. The outputs of both these comparators are fed into an OR GATE and

HV9910C

the output of the OR GATE is fed into the reset pin of the flip-flop. Thus, the comparator which has the lowest voltage at the inverting terminal determines when the GATE output is turned off.

The outputs of the comparators also include a 150-280ns blanking time which prevents spurious turn-offs of the external FET due to the turn-on spike normally present in peak-current mode control. In rare cases, this internal blanking might not be enough to filter out the turn-on spike. In these instances, an external RC filter needs to be added between the external sense resistor (RCS) and the CS pin.

Please note that the comparators are fast (with a typical 80ns response time). A proper layout minimizing external inductances will prevent false triggering of these comparators.

3.3 Oscillator

The oscillator in HV9910C is controlled by a single resistor connected at the RT pin. The equation governing the oscillator time period T_{osc} is given by:

$$T_{osc}(\mu s) = \frac{R_{osc}(k\Omega)}{25}$$

If the resistor is connected between RT and GND, HV9910C operates in a constant frequency mode and the above equation determines the time period. If the resistor is connected between RT and GATE, HV9910C operates in a constant off-time mode and the above equation determines the off-time.

3.4 Gate Output

The gate output of the HV9910C is used to drive an external FET. It is recommended that the GATE charge of the external FET be less than 25nC for switching frequencies ≤ 100 kHz and less than 15nC for switching frequencies > 100 kHz.

3.5 Linear Dimming

The Linear Dimming pin is used to control the LED current. There are two cases when it may be necessary to use the Linear Dimming pin.

1. In some cases, when using the internal 250mV, it may not be possible to find the exact R_{CS} value required to obtain the LED current. In these cases, an external voltage divider from the V_{DD} pin can be connected to the LD pin to obtain a voltage (less than 250mV) corresponding to the desired voltage across RCS.
2. Linear dimming may be desired to adjust the current level to reduce the intensity of the LEDs. In these cases, an external 0-250mV voltage

can be connected to the LD pin to adjust the LED current during operation.

To use the internal 250mV, the LD pin can be connected to V_{DD} .

Note: Although the LD pin can be pulled to GND, the output current will not go to zero. This is due to the presence of a minimum on-time, which is equal to the sum of the blanking time and the delay to output time, or about 450ns. This minimum on-time causes the FET to be on for a minimum of 450ns, and thus the LED current when LD = GND is not zero. This current is also dependent on the input voltage, inductance value, forward voltage of the LEDs, and circuit parasitics. To get zero LED current, the PWMD pin has to be used.

3.6 PWM Dimming

PWM Dimming can be achieved by driving the PWMD pin with a low frequency square wave signal. When the PWM signal is zero, the GATE driver is turned off; when the PWM signal is high, the GATE driver is enabled. The PWMD signal does not turn off the other parts of the IC, therefore, the response of HV9910C to the PWMD signal is almost instantaneous. The rate of rise and fall of the LED current is thus determined solely by the rise and fall times of the inductor current.

To disable PWM Dimming and enable the HV9910C permanently, connect the PWMD pin to V_{DD} .

3.7 Over-Temperature Protection

The auto-recoverable thermal shutdown at 140°C (typ.) junction temperature with 20°C hysteresis is featured to avoid thermal runaway. When the junction temperature reaches $T_{SD} = 140^\circ\text{C}$ (typ.), HV9910C enters a low power consumption shut-down mode with $I_{IN} < 350\mu\text{A}$.

FIGURE 3-1: INTERNAL BLOCK DIAGRAM

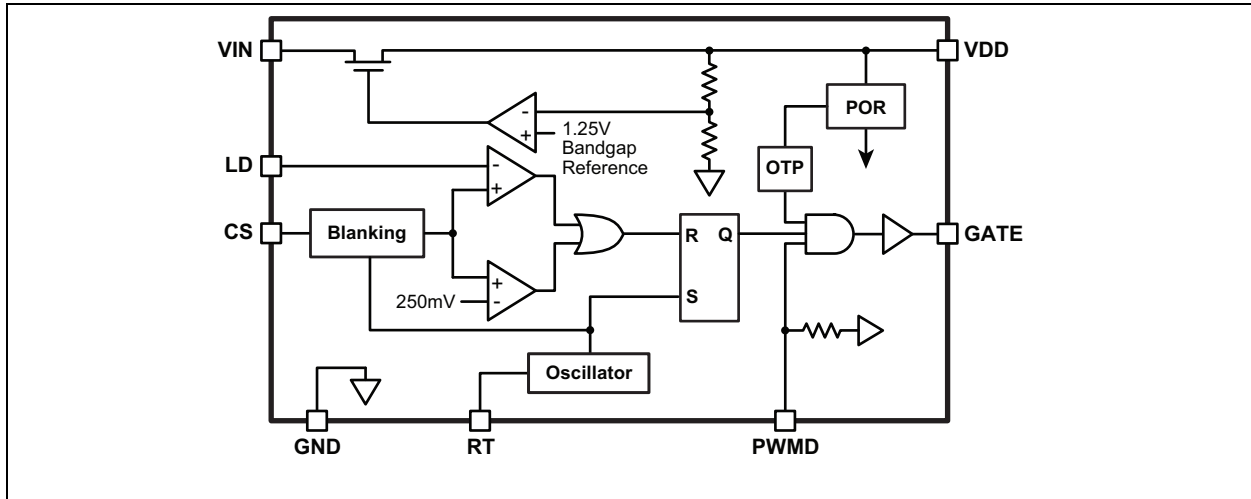

HV9910C

4.0 PACKAGING INFORMATION

4.1 Package Marking Information

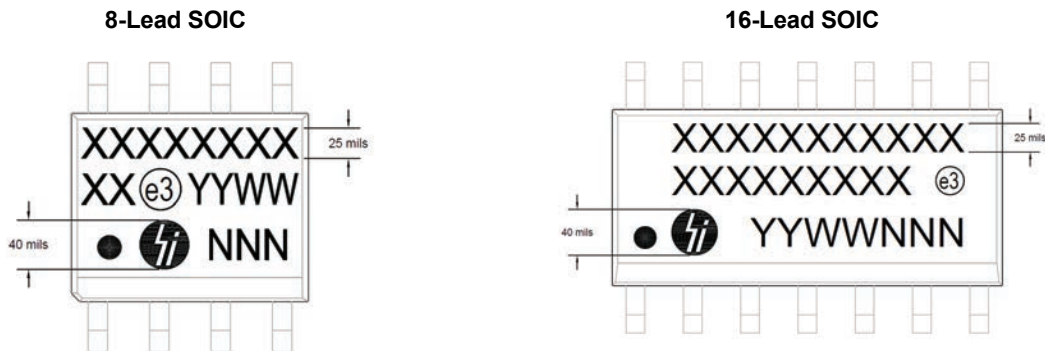

- X = Product Code
- YY = Year Sealed
- WW = Week Sealed
- NNN = Traceability Code
- e# = JEDEC Symbol
- = Pin 1 Indicator

Note: The JEDEC environmental marking symbols (e#) illustrated are examples only, and might not reflect the actual value for the listed package code.

FIGURE 4-1: 8-LEAD SOIC (NARROW BODY) PACKAGE OUTLINE (LG)

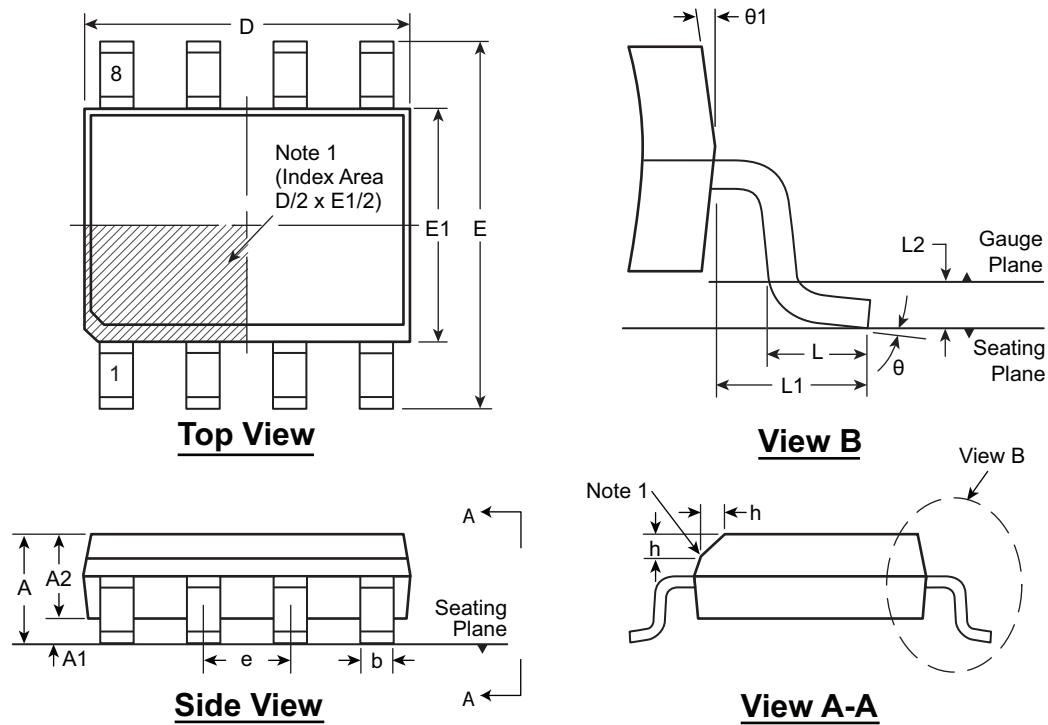

Notes:

1. This chamfer feature is optional. A Pin 1 identifier must be located in the index area indicated. The Pin 1 identifier can be: a molded mark/identifier; an embedded metal marker; or a printed indicator.

Symbol		A	A1	A2	b	D	E	E1	e	h	L	L1	L2	θ	θ_1
Dimension (mm)	MIN	1.35*	0.10	1.25	0.31	4.80*	5.80*	3.80*	1.27 BSC	0.25	0.40	1.04 REF	0.25 BSC	0°	5°
	NOM	-	-	-	-	4.90	6.00	3.90		-	-			-	-
	MAX	1.75	0.25	1.65*	0.51	5.00*	6.20*	4.00*		0.50	1.27			8°	15°

JEDEC Registration MS-012, Variation AA, Issue E, Sep 2005.

* This dimension is not specified in the JEDEC drawing.

† This dimension differs from the JEDEC drawing.

Drawings not to scale.

HV9910C

FIGURE 4-2: 16-LEAD SOIC (NARROW BODY) PACKAGE OUTLINE (NG)

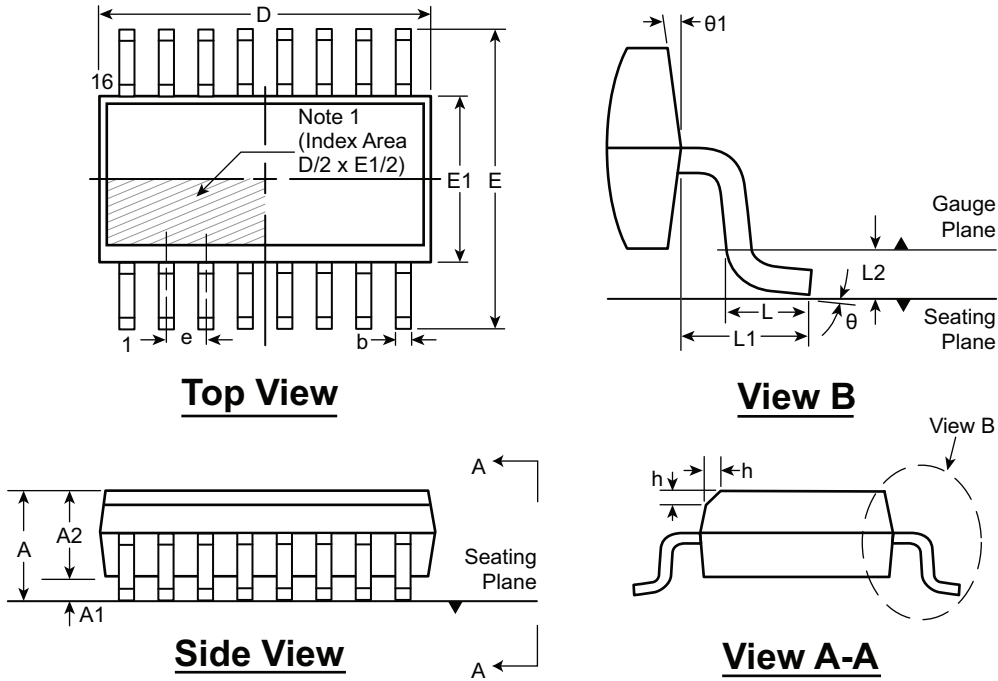

Notes:

1. This chamfer feature is optional. A Pin 1 identifier must be located in the index area indicated. The Pin 1 identifier can be: a molded mark/identifier; an embedded metal marker; or a printed indicator.

Symbol		A	A1	A2	b	D	E	E1	e	h	L	L1	L2	θ	θ1
Dimension (mm)	MIN	1.35*	0.10	1.25	0.31	9.80*	5.80*	3.80*	1.27 BSC	0.25	0.40	1.04 REF	0.25 BSC	0°	5°
	NOM	-	-	-	-	9.90	6.00	3.90		-	-			-	-
	MAX	1.75	0.25	1.65*	0.51	10.00*	6.20*	4.00*		0.50	1.27			8°	15°

JEDEC Registration MS-012, Variation AC, Issue E, Sep 2005.

* This dimension is not specified in the JEDEC drawing.

† This dimension differs from the JEDEC drawing.

Drawings not to scale.

FIGURE 4-3: 8-LEAD SOIC (NARROW BODY) PACKAGE OUTLINE (SG)

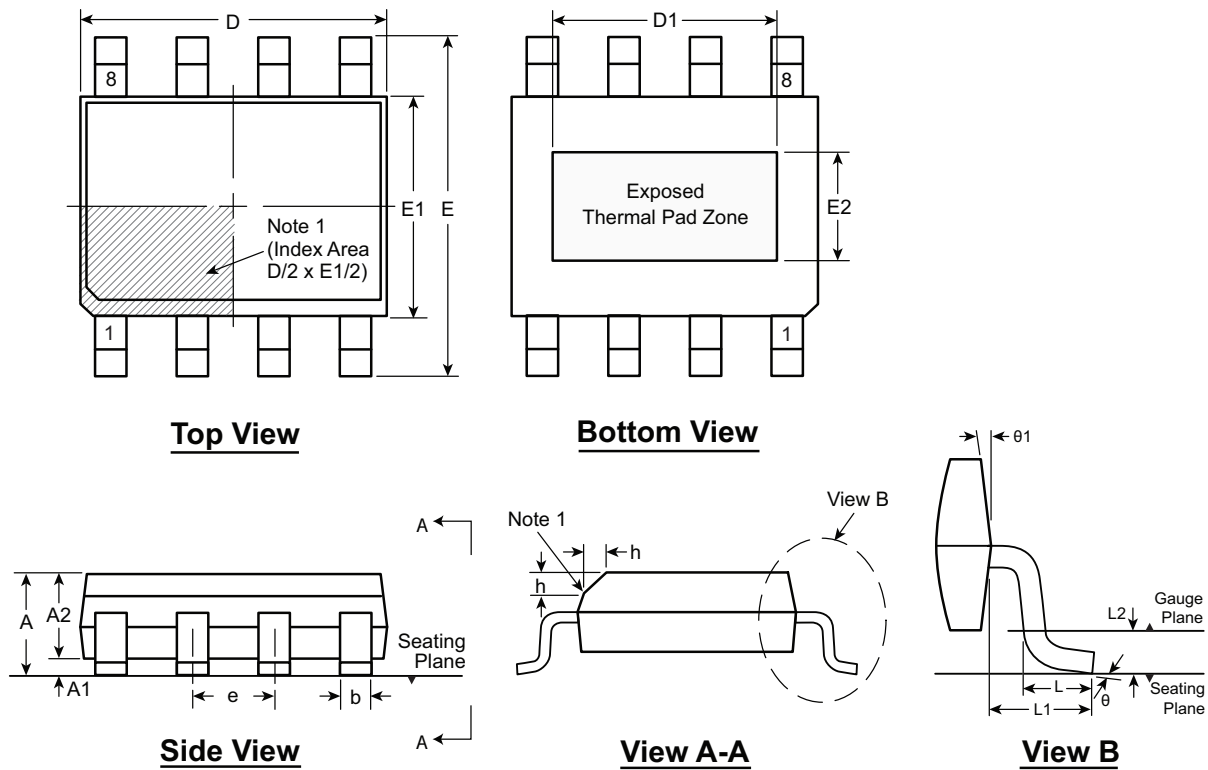

Notes:

1. This chamfer feature is optional. A Pin 1 identifier must be located in the index area indicated. The Pin 1 identifier can be: a molded mark/identifier; an embedded metal marker; or a printed indicator.

Symbol	A	A1	A2	b	D	D1	E	E1	E2	e	h	L	L1	L2	θ	θ1					
Dimension (mm)	MIN	1.25*	0.00	1.25	0.31	4.80*	3.30†	5.80*	3.80*	2.29†	1.27 BSC	0.25	0.40	1.04 REF	0.25	BSC	0°	5°			
	NOM	-	-	-	-	4.90	-	6.00	3.90	-		-	-		-		-	-	-	-	-
	MAX	1.70	0.15	1.55*	0.51	5.00*	3.81†	6.20*	4.00*	2.79†		0.50	1.27		8°		15°				

JEDEC Registration MS-012, Variation BA, Issue E, Sep 2005.

* This dimension is not specified in the JEDEC drawing.

† This dimension differs from the JEDEC drawing.

Drawings not to scale.

HV9910C

APPENDIX A: REVISION HISTORY

Revision A (August 2014)

- Original Release of this Document.

THE MICROCHIP WEB SITE

Microchip provides online support via our WWW site at www.microchip.com. This web site is used as a means to make files and information easily available to customers. Accessible by using your favorite Internet browser, the web site contains the following information:

- **Product Support** – Data sheets and errata, application notes and sample programs, design resources, user's guides and hardware support documents, latest software releases and archived software
- **General Technical Support** – Frequently Asked Questions (FAQ), technical support requests, online discussion groups, Microchip consultant program member listing
- **Business of Microchip** – Product selector and ordering guides, latest Microchip press releases, listing of seminars and events, listings of Microchip sales offices, distributors and factory representatives

CUSTOMER CHANGE NOTIFICATION SERVICE

Microchip's customer notification service helps keep customers current on Microchip products. Subscribers will receive e-mail notification whenever there are changes, updates, revisions or errata related to a specified product family or development tool of interest.

To register, access the Microchip web site at www.microchip.com. Under "Support", click on "Customer Change Notification" and follow the registration instructions.

CUSTOMER SUPPORT

Users of Microchip products can receive assistance through several channels:

- Distributor or Representative
- Local Sales Office
- Field Application Engineer (FAE)
- Technical Support

Customers should contact their distributor, representative or Field Application Engineer (FAE) for support. Local sales offices are also available to help customers. A listing of sales offices and locations is included in the back of this document.

Technical support is available through the web site at: <http://microchip.com/support>

HV9910C

PRODUCT IDENTIFICATION SYSTEM

To order or obtain information, e.g., on pricing or delivery, refer to the factory or the listed sales office.

<u>PART NO.</u>	XX	-	X	-	X
Device	Package Options		Environmental		Reel
Device: HV9910C= Universal High-Brightness LED Driver Package: LG = 8-lead SOIC NG = 16-lead SOIC SG = 8-lead SOIC with head slug Environmental G = Lead (Pb)-free/ROHS-compliant package Reel: (nothing) = Reel for LG and SG packages, Tube for NG package M934 = Reel for NG package	Examples: a) HV9910CLG-G: 8-lead SOIC package, 2500/Reel. b) HV9910CNG-G 16-lead SOIC package, 45/Tube c) HV9910CNG-G-M934: 16-lead SOIC package, 2500/Reel. d) HV9910CSG-G: 8-lead SOIC package with heat slug, 2500/Reel.				

Note the following details of the code protection feature on Microchip devices:

- Microchip products meet the specification contained in their particular Microchip Data Sheet.
- Microchip believes that its family of products is one of the most secure families of its kind on the market today, when used in the intended manner and under normal conditions.
- There are dishonest and possibly illegal methods used to breach the code protection feature. All of these methods, to our knowledge, require using the Microchip products in a manner outside the operating specifications contained in Microchip's Data Sheets. Most likely, the person doing so is engaged in theft of intellectual property.
- Microchip is willing to work with the customer who is concerned about the integrity of their code.
- Neither Microchip nor any other semiconductor manufacturer can guarantee the security of their code. Code protection does not mean that we are guaranteeing the product as “unbreakable.”

Code protection is constantly evolving. We at Microchip are committed to continuously improving the code protection features of our products. Attempts to break Microchip's code protection feature may be a violation of the Digital Millennium Copyright Act. If such acts allow unauthorized access to your software or other copyrighted work, you may have a right to sue for relief under that Act.

Information contained in this publication regarding device applications and the like is provided only for your convenience and may be superseded by updates. It is your responsibility to ensure that your application meets with your specifications. MICROCHIP MAKES NO REPRESENTATIONS OR WARRANTIES OF ANY KIND WHETHER EXPRESS OR IMPLIED, WRITTEN OR ORAL, STATUTORY OR OTHERWISE, RELATED TO THE INFORMATION, INCLUDING BUT NOT LIMITED TO ITS CONDITION, QUALITY, PERFORMANCE, MERCHANTABILITY OR FITNESS FOR PURPOSE. Microchip disclaims all liability arising from this information and its use. Use of Microchip devices in life support and/or safety applications is entirely at the buyer's risk, and the buyer agrees to defend, indemnify and hold harmless Microchip from any and all damages, claims, suits, or expenses resulting from such use. No licenses are conveyed, implicitly or otherwise, under any Microchip intellectual property rights.

Trademarks

The Microchip name and logo, the Microchip logo, dsPIC, FlashFlex, KEELOQ, KEELOQ logo, MPLAB, PIC, PICmicro, PICSTART, PIC³² logo, rPIC, SST, SST Logo, SuperFlash and UNI/O are registered trademarks of Microchip Technology Incorporated in the U.S.A. and other countries.

FilterLab, Hampshire, HI-TECH C, Linear Active Thermistor, MTP, SEEVAL and The Embedded Control Solutions Company are registered trademarks of Microchip Technology Incorporated in the U.S.A.

Silicon Storage Technology is a registered trademark of Microchip Technology Inc. in other countries.

Analog-for-the-Digital Age, Application Maestro, BodyCom, chipKIT, chipKIT logo, CodeGuard, dsPICDEM, dsPICDEM.net, dsPICworks, dsSPEAK, ECAN, ECONOMONITOR, FanSense, HI-TIDE, In-Circuit Serial Programming, ICSP, Mindi, MiWi, MPASM, MPF, MPLAB Certified logo, MPLIB, MPLINK, mTouch, Omniclient Code Generation, PICC, PICC-18, PICDEM, PICDEM.net, PICkit, PICTail, REAL ICE, rLAB, Select Mode, SQI, Serial Quad I/O, Total Endurance, TSHARC, UniWinDriver, WiperLock, ZENA and Z-Scale are trademarks of Microchip Technology Incorporated in the U.S.A. and other countries.

SQTP is a service mark of Microchip Technology Incorporated in the U.S.A.

GestIC and ULPP are registered trademarks of Microchip Technology Germany II GmbH & Co. KG, a subsidiary of Microchip Technology Inc., in other countries.

All other trademarks mentioned herein are property of their respective companies.

© 2014, Microchip Technology Incorporated, Printed in the U.S.A., All Rights Reserved.

 Printed on recycled paper.

ISBN: 978-1-63276-529-1

QUALITY MANAGEMENT SYSTEM
CERTIFIED BY DNV
== ISO/TS 16949 ==

Microchip received ISO/TS-16949:2009 certification for its worldwide headquarters, design and wafer fabrication facilities in Chandler and Tempe, Arizona; Gresham, Oregon and design centers in California and India. The Company's quality system processes and procedures are for its PIC[®] MCUs and dsPIC[®] DSCs, KEELOQ[®] code hopping devices, Serial EEPROMs, microperipherals, nonvolatile memory and analog products. In addition, Microchip's quality system for the design and manufacture of development systems is ISO 9001:2000 certified.



MICROCHIP

Worldwide Sales and Service

AMERICAS

Corporate Office

2355 West Chandler Blvd.
Chandler, AZ 85224-6199
Tel: 480-792-7200
Fax: 480-792-7277
Technical Support:
<http://www.microchip.com/support>

Web Address:
www.microchip.com

Atlanta

Duluth, GA
Tel: 678-957-9614
Fax: 678-957-1455

Austin, TX

Tel: 512-257-3370

Boston

Westborough, MA
Tel: 774-760-0087
Fax: 774-760-0088

Chicago

Itasca, IL
Tel: 630-285-0071
Fax: 630-285-0075

Cleveland

Independence, OH
Tel: 216-447-0464
Fax: 216-447-0643

Dallas

Addison, TX
Tel: 972-818-7423
Fax: 972-818-2924

Detroit

Novi, MI
Tel: 248-848-4000

Houston, TX

Tel: 281-894-5983

Indianapolis

Noblesville, IN
Tel: 317-773-8323
Fax: 317-773-5453

Los Angeles

Mission Viejo, CA
Tel: 949-462-9523
Fax: 949-462-9608

New York, NY

Tel: 631-435-6000

San Jose, CA

Tel: 408-735-9110

Canada - Toronto

Tel: 905-673-0699
Fax: 905-673-6509

ASIA/PACIFIC

Asia Pacific Office

Suites 3707-14, 37th Floor
Tower 6, The Gateway
Harbour City, Kowloon
Hong Kong
Tel: 852-2943-5100
Fax: 852-2401-3431

Australia - Sydney

Tel: 61-2-9868-6733
Fax: 61-2-9868-6755

China - Beijing

Tel: 86-10-8569-7000
Fax: 86-10-8528-2104

China - Chengdu

Tel: 86-28-8665-5511
Fax: 86-28-8665-7889

China - Chongqing

Tel: 86-23-8980-9588
Fax: 86-23-8980-9500

China - Hangzhou

Tel: 86-571-8792-8115
Fax: 86-571-8792-8116

China - Hong Kong SAR

Tel: 852-2943-5100
Fax: 852-2401-3431

China - Nanjing

Tel: 86-25-8473-2460
Fax: 86-25-8473-2470

China - Qingdao

Tel: 86-532-8502-7355
Fax: 86-532-8502-7205

China - Shanghai

Tel: 86-21-5407-5533
Fax: 86-21-5407-5066

China - Shenyang

Tel: 86-24-2334-2829
Fax: 86-24-2334-2393

China - Shenzhen

Tel: 86-755-8864-2200
Fax: 86-755-8203-1760

China - Wuhan

Tel: 86-27-5980-5300
Fax: 86-27-5980-5118

China - Xian

Tel: 86-29-8833-7252
Fax: 86-29-8833-7256

China - Xiamen

Tel: 86-592-2388138
Fax: 86-592-2388130

China - Zhuhai

Tel: 86-756-3210040
Fax: 86-756-3210049

ASIA/PACIFIC

India - Bangalore

Tel: 91-80-3090-4444
Fax: 91-80-3090-4123

India - New Delhi

Tel: 91-11-4160-8631
Fax: 91-11-4160-8632

India - Pune

Tel: 91-20-3019-1500

Japan - Osaka

Tel: 81-6-6152-7160
Fax: 81-6-6152-9310

Japan - Tokyo

Tel: 81-3-6880-3770
Fax: 81-3-6880-3771

Korea - Daegu

Tel: 82-53-744-4301
Fax: 82-53-744-4302

Korea - Seoul

Tel: 82-2-554-7200
Fax: 82-2-558-5932 or
82-2-558-5934

Malaysia - Kuala Lumpur

Tel: 60-3-6201-9857
Fax: 60-3-6201-9859

Malaysia - Penang

Tel: 60-4-227-8870
Fax: 60-4-227-4068

Philippines - Manila

Tel: 63-2-634-9065
Fax: 63-2-634-9069

Singapore

Tel: 65-6334-8870
Fax: 65-6334-8850

Taiwan - Hsin Chu

Tel: 886-3-5778-366
Fax: 886-3-5770-955

Taiwan - Kaohsiung

Tel: 886-7-213-7830

Taiwan - Taipei

Tel: 886-2-2508-8600
Fax: 886-2-2508-0102

Thailand - Bangkok

Tel: 66-2-694-1351
Fax: 66-2-694-1350

EUROPE

Austria - Wels

Tel: 43-7242-2244-39
Fax: 43-7242-2244-393

Denmark - Copenhagen

Tel: 45-4450-2828
Fax: 45-4485-2829

France - Paris

Tel: 33-1-69-53-63-20
Fax: 33-1-69-30-90-79

Germany - Dusseldorf

Tel: 49-2129-3766400

Germany - Munich

Tel: 49-89-627-144-0
Fax: 49-89-627-144-44

Germany - Pforzheim

Tel: 49-7231-424750

Italy - Milan

Tel: 39-0331-742611
Fax: 39-0331-466781

Italy - Venice

Tel: 39-049-7625286

Netherlands - Drunen

Tel: 31-416-690399
Fax: 31-416-690340

Poland - Warsaw

Tel: 48-22-3325737

Spain - Madrid

Tel: 34-91-708-08-90
Fax: 34-91-708-08-91

Sweden - Stockholm

Tel: 46-8-5090-4654

UK - Wokingham

Tel: 44-118-921-5800
Fax: 44-118-921-5820

03/25/14