



Chipsmall Limited consists of a professional team with an average of over 10 year of expertise in the distribution of electronic components. Based in Hongkong, we have already established firm and mutual-benefit business relationships with customers from,Europe,America and south Asia,supplying obsolete and hard-to-find components to meet their specific needs.

With the principle of “Quality Parts,Customers Priority,Honest Operation,and Considerate Service”,our business mainly focus on the distribution of electronic components. Line cards we deal with include Microchip,ALPS,ROHM,Xilinx,Pulse,ON,Everlight and Freescale. Main products comprise IC,Modules,Potentiometer,IC Socket,Relay,Connector.Our parts cover such applications as commercial,industrial, and automotives areas.

We are looking forward to setting up business relationship with you and hope to provide you with the best service and solution. Let us make a better world for our industry!



Contact us

Tel: +86-755-8981 8866 Fax: +86-755-8427 6832

Email & Skype: info@chipsmall.com Web: www.chipsmall.com

Address: A1208, Overseas Decoration Building, #122 Zhenhua RD., Futian, Shenzhen, China



High Voltage Differential Probes

HVD3605A, HVD3206A
HVD310xA



Key Features

- 1 kV, 2 kV, 6 kV CAT safety rated models
- Widest differential voltage ranges available
- Exceptional common-mode rejection ratio (CMRR) across a broad frequency range
- 1% gain accuracy
- High offset capability at both high and low attenuation
- AC and DC coupling
- ProBus active probe interface with automatic scaling
- AutoZero with auto disconnect switch
- Wide oscilloscope compatibility

The HVD3000A series high voltage differential probes provide high CMRR over a broad frequency range to simplify the measurement challenges found in noisy, high common-mode power electronics environments. The probe's design is easy-to-use and enables safe, precise high voltage floating measurements.

Exceptional Common-Mode Rejection Ratio

The CMRR for the probes is exceptional out to very high frequencies, greatly improving measurement capability in the noisy, high common-mode environments found in power electronics. The high CMRR combined with low probe noise and high offset capability provides superior measurement capabilities compared to other HV differential probes.

High Precision Measurements

HVD3000A series probes provide 1% gain accuracy enabling precise voltage measurements. AutoZero capability ensures further measurement precision by allowing small offset drifts to be calibrated out of the measurement. This feature can be applied without removing the HVD3000A leads from the device under test.

Widest Application Coverage

The HVD3000A series cover the fullest range of applications, from 120/240 V switch-mode power supplies through 600 V class and 5 kV class electrical apparatus. Each model has the best available gain accuracy, widest differential and offset voltage range, and superior CMRR.

1500 Vdc CAT III Rating

The HVD3206A supports 1500 V_{dc} solar photovoltaic (PV) measurements per the IEC/EN 61010-031:2015 standard. It has a 1500 V_{dc} CAT III and a 2000 V (DC+peakAC) CAT I rating.

Complete Probe Integration

The ProBus interface provides power and communication to the probe eliminating the need for a separate power supply or batteries. Attenuation is automatically selected based on oscilloscope gain range (V/div) setting.

WIDE APPLICATION COVERAGE - 600 V TO 5 KV APPARATUS

600 V Class, 3-phase Electrical Apparatus

The HVD310xA probes are available in a range of bandwidths from 25 to 120 MHz with standard 2 meter cable (6 meter cable model available). All probes have industry best CMRR for best noise-immunity, are guaranteed to 1% gain accuracy, and have the industry's widest differential voltage range in a 1 kV rated high voltage differential probe.

- Only 1 kV safety rated probe that serves the full 600 V class requirement
- 1500 V differential range with industry's best overshoot measurement capability (to 2000 V_{pk})
- Industry's best offset capability (1500 V) when used with HDO Series oscilloscopes
- Bandwidth rating up to 120 MHz
- 6 meter cable model available (HVD3106A-6M)
- Models available without accessories for a lower cost (HVD310xA-NOACC)

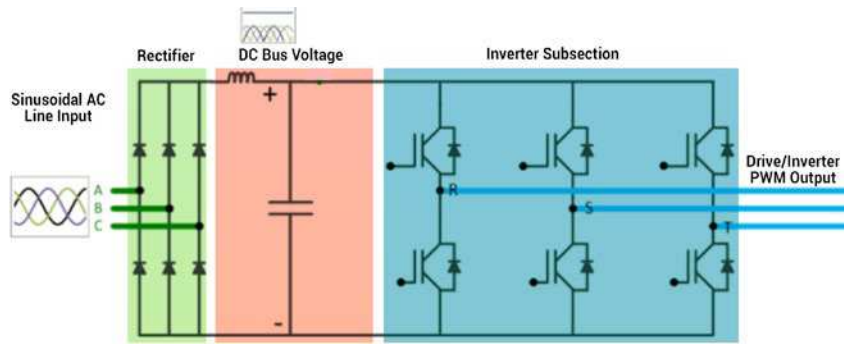

Sinusoidal AC Line Input			DC Bus Voltage V _{dc}	Drive / Inverter Pulse-Width Modulated (PWM) Output			
V _{rms} or V _{ac}	V _{pk-pk}			V _{pk} (Rated)		V _{pk} (with Overshoot)*	
	Line-Line	Line-Neutral		Line-Line	Line-Neutral	Line-Line	Line-Neutral
400	1131	653	566	566	327	849	491
480	1358	784	679	679	392	1019	588
600	1697	980	849	849	490	1274	735
690	1952	1127	976	976	563	1464	845

*Based on 50% overshoot condition

5 kV Class, 3-phase Electrical Apparatus

The HVD3605A probe is safety-rated for 6000 V_{rms} and 8485 V(DC + peak AC) for full coverage of 5 kV class apparatus. The probe has ample 100 MHz of bandwidth, is standard with a 6 meter cable, is guaranteed to 1% gain accuracy, has excellent CMRR, and has the industry's widest differential voltage range.

- Only probe that permits AC Line, DC Bus, and Drive/Inverter output voltage probing through 4160 V apparatus ratings
- Industry's best overshoot measurement capability (to 7600 V_{pk})
- Industry's best offset capability (6000 V) when used with HDO Series oscilloscopes
- Standard 6 meter cable

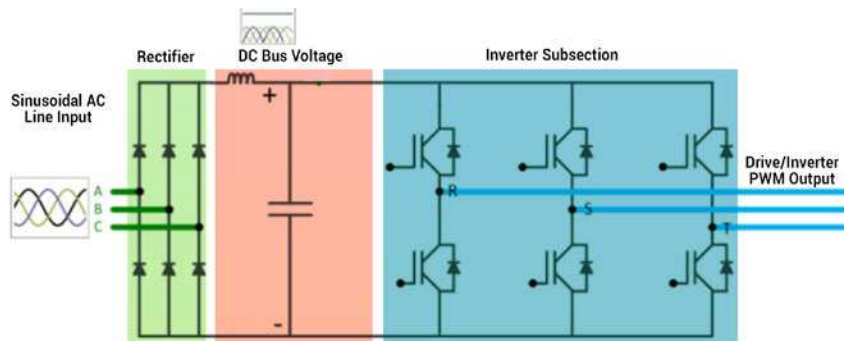

Sinusoidal AC Line Input			DC Bus Voltage V _{dc}	Drive / Inverter Pulse-Width Modulated (PWM) Output			
V _{rms} or V _{ac}	V _{pk-pk}			V _{pk} (Rated)		V _{pk} (with Overshoot)*	
	Line-Line	Line-Neutral		Line-Line	Line-Neutral	Line-Line	Line-Neutral
2400	6788	3920	3395	3395	1960	4244	2450
3300	9334	5388	4666	4666	2694	5833	3368
4160	11766	6794	5884	5884	3397	7355	4246

*Based on 25% overshoot condition

WORLD'S ONLY 2 KV SAFETY RATED MODEL

Solar PV Inverters

The HVD3206A probe is rated to 1500 V_{DC} (2000 V DC + peak AC). This makes the probe ideal for testing single-phase or three-phase inverters or newer 1500 V_{DC} rated string-inverters (per IEC/EN 61010-031:2015). The HVD3206A has the same excellent 1% gain accuracy, industry-leading CMRR, industry-best offset range, standard 2 meter cable (6 meter cable model available), and a guaranteed 2000 V_{pk} differential voltage range.

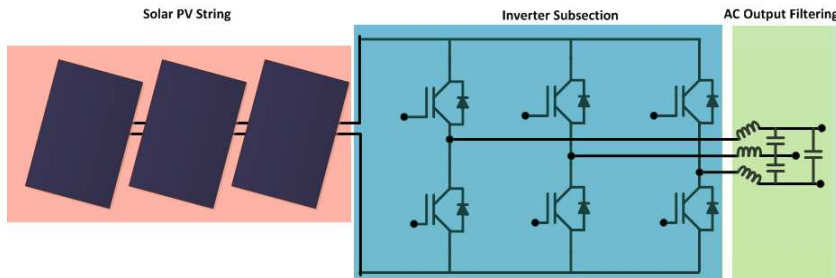

Solar String DC Bus Voltage	Sinusoidal AC Output			
	V _{pk} (Rated)		V _{pk} (with Overshoot)*	
	Line-Line	Line-Neutral	Line-Line	Line-Neutral
1000	849	490	1104	637
1500	849	490	1104	637

*Based on 30% overshoot condition

- Only 1500 V_{DC} safety rated probe per IEC/EN 61010-031:2015
- Guaranteed 2000 V_{pk} differential voltage range
- Industry's best offset capability (1500 V) when used with HDO Series oscilloscopes
- Bandwidth rating up to 120 MHz
- 6 meter cable model available (HVD3206A-6M)

DC-DC Converters

High-power DC-DC converters can operate at substantial voltages, 500 V_{DC} or higher. The HVD310xA models provide up to 1000 V_{DC} common-mode (HVD3206A models provide up to 1500 V_{DC}) and high precision (1% gain accuracy) DC voltage measurements. Automatic switchable attenuation keeps the probe in the optimum measurement range. Multiple probes can be used to understand complex device switching performance.

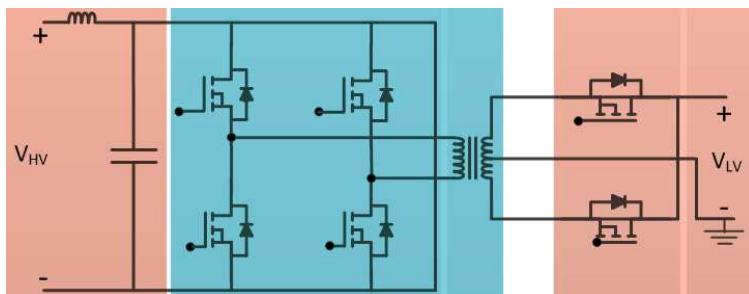

- Common mode range up to ±2000 V (DC + peak AC) with HVD3206A
- High precision - 1% accuracy
- Automatic gain switching for optimum performance

SUPERIOR PERFORMANCE AT LOWER VOLTAGES

120 V / 240 V Half-Bridge Circuit Topologies

Single-phase switch-mode power supplies and other devices utilizing half-bridge topologies need test and validation at DC bus voltages up to 340 V_{DC} with up to 680 V_{p-p} on the input voltage. HVD310xA probes are cost-effective solutions for probing the wide range of high voltage signals present in these systems. "No Accessory (NOACC)" versions of these probes permit additional cost savings. Use your existing accessories or purchase just the ones you want.

- High precision - 1% accuracy
- Automatic gain switching for optimum performance

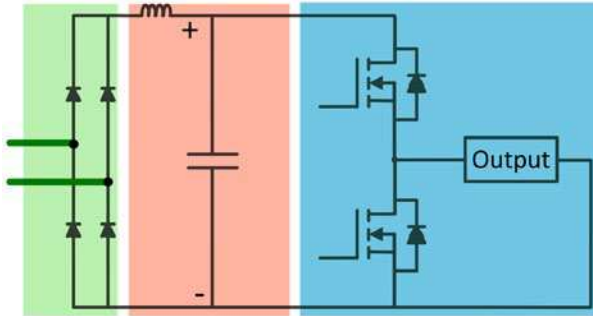

Input Voltage (V _{rms} or V _{ac})	Input Voltage (V _{pk-pk})	DC Bus Voltage (V _{dc})	Output PWM Voltage (V _{pk})
120	340	170	170
240	680	340	340

MOSFET/IGBT Devices

Upper-side Gate Drive Voltage Measurements

Typically from 3 to 20 volts and "floating" at up to the DC Bus voltage. HVD-A Series probes can provide very good results, but the HVFO High Voltage Fiber Optic probe is optimized for the best upper-side gate drive voltage measurements with 140 dB CMRR, reduced DUT loading, and better pulse response.



Device Analysis

Conduction loss or R_{ds(on)} measurements require a voltage probing solution that has high CMRR, fast overdrive recovery, voltage clamping (so the oscilloscope is not overdriven), compensation flatness, gain/amplification to see small signal details, and precise offset generation to see the switching device's turn-off performance. For this type of analysis, the Teledyne LeCroy DA1855A Differential Amplifier is the best solution. It provides 100 MHz bandwidth, excellent common mode rejection ratio (CMRR) of 100,000:1 (typical), and overdrive recovery to within 100 mV from a 400 V input signal in less than 100 ns.

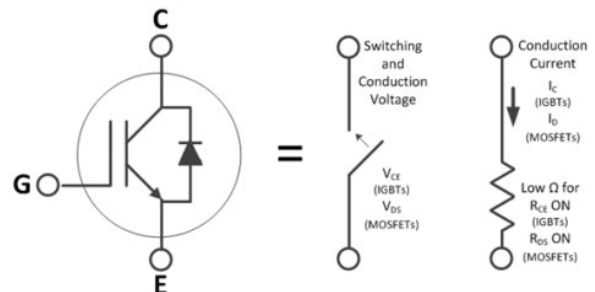

UNDERSTANDING HV DIFFERENTIAL PROBE RATINGS

AC line voltages and power electronics systems can operate at very high voltages, and all parts of the measurement circuit are not necessarily connected to ground, requiring HV safety ratings. Additionally, a variety of terms may be used to describe the same voltage. Below is a simple tutorial to help you understand the various types of voltage terms and how they relate to each other. Understanding these voltage terms is necessary to ensure the correct probe selection.

Single-phase AC Line Input

Ratings are provided in V_{RMS} (also referred to as V_{AC}) referred Line-Neutral. AC Line inputs are usually grounded and these voltages can be assumed to have a 0V reference voltage.

V_{peak} is calculated as $\sqrt{2} * V_{RMS}$ and V_{pk-pk} is calculated as $2 * V_{peak}$. The example to the right is for a 120 V_{RMS} rating.

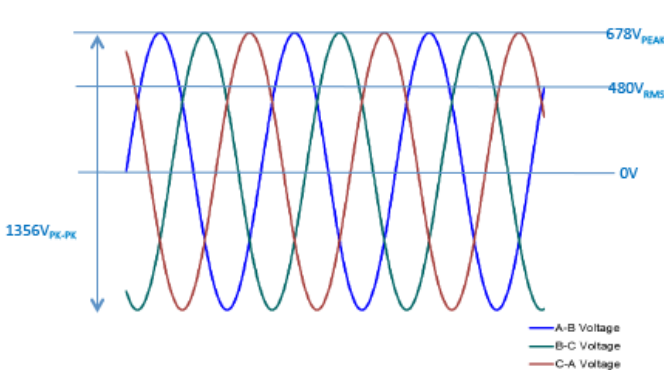
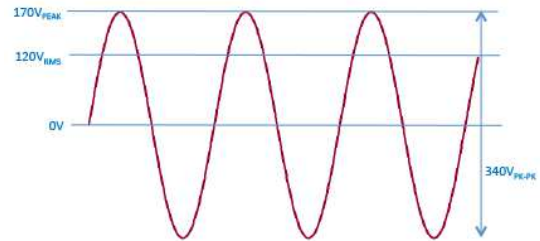

Three-phase AC Line Input

Ratings are provided in V_{RMS} (also referred to as V_{AC}) referred Line-Line (L-L), which can be converted in magnitude to a Line-Neutral basis by dividing by $\sqrt{3}$.

V_{peak} (L-L) is calculated $\sqrt{2} * V_{RMS}$ and V_{pk-pk} is calculated as $2 * V_{peak}$. The example on the left is for a 480 V_{RMS} three-phase rated system with signals shown as Line-Line.

Rectified AC (DC Bus/Link Voltage)

For three-phase inputs, the three Line-Neutral (L-N) AC Line inputs are rectified and summed to provide a "stiff" DC (bus/link) voltage for the input to an inverter subsection.

The example shown to the right is for a 600 V_{RMS} system.

The Line-Neutral RMS voltages are $600V/\sqrt{3}$, and each $V_{peak}(L-N)$ is calculated as $\sqrt{2} * V_{RMS}$. The DC bus voltage after rectification and filtering is equal to $\sqrt{3} * V_{peak}(L-N)$, or 847 V_{DC} in this case.

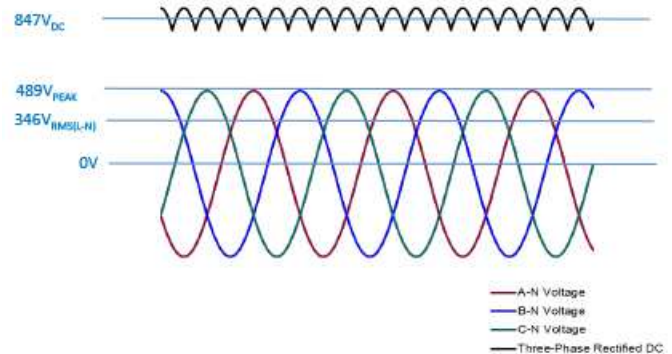

Inverter or Drive H-Bridge or Cascaded H-Bridge Outputs

The nominal peak voltage (+ or -) of the PWM signals without accounting for signal overshoot is equal to the DC bus voltage. The measured 0V differential voltage value is not ground-referenced, and therefore a differential probe suitably rated to the DC bus voltage is recommended. Note that the $+V_{peak}$ and $-V_{peak}$ plus overshoot safety margin (typically ~50%) is what the HV differential probe must measure - V_{pk-pk} ($2 * V_{peak}$) will never occur in the circuit.

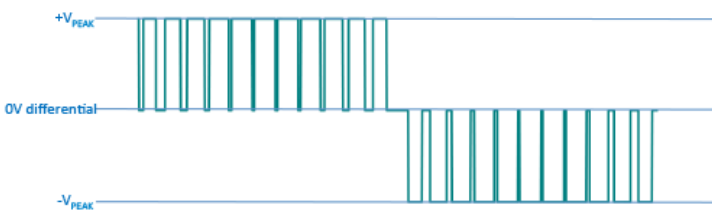

SPECIFICATIONS

	HVD3102A	HVD3106A	HVD3106A-6M
Bandwidth	25 MHz	120 MHz	80 MHz
Rise Time (10-90)	14 ns	2.9 ns	4.4 ns
Differential Voltage Range (High Attenuation)	1500 V (DC + peak AC) from 7 to 500 V/div with up to 1500 V offset. 1750 V maximum typical measurable differential voltage before saturation.	1500 V (DC + peak AC) from 7 to 500 V/div with up to 1500 V offset. 2000 V maximum typical measurable differential voltage before saturation	
Differential Voltage Range (Low Attenuation)	27.6 V (DC + peak AC) from 100 mV/div to 6.9 V/div with up to 150 V offset		
Common Mode Voltage Range	±1500 V (DC + peak AC), 1000 V _{rms}		
Maximum Input Voltage to Earth	±1500 V _{pk} (nominal, either input to ground)		
Max Safe Input Voltage	1000 V _{rms} CAT III		
Sensitivity	100 mV/div to 6.9V/div (100X) 7V/div to 500V/div (1000X)	100 mV/div to 6.9V/div (50X) 7V/div to 500V/div (500X)	100 mV/div to 6.9V/div (50X) 7V/div to 500V/div (500X)
Gain Accuracy	1% (LF, guaranteed)		
Slew Rate	100 V/ns (maximum)	400 V/ns (maximum)	270 V/ns (maximum)
Attenuation	100x / 1000x	50x / 500x	50x / 500x
Input Impedance	10 MΩ 2.5 pF (between inputs), 5 MΩ 5.0 pF (either input to ground)		
Input Coupling	DC only		
Output Coupling	AC or DC coupling		
Output Termination	1 MΩ		
Interface	ProBus		
Input Lead Length	40 cm input lead length		
Cable Length (input lead to oscilloscope connection)	2.25 m		6.8 m
Noise and Rejection			
CMRR (Typical)	DC - 60 Hz: 85 dB 1 MHz: 65 dB 5 MHz: 40 dB 20 MHz: 30 dB	DC - 60 Hz: 85 dB 1 MHz: 65 dB 5 MHz: 40 dB 20 MHz: 30 dB 100 MHz: 30 dB	DC - 60 Hz: 85 dB 1 MHz: 65 dB 5 MHz: 40 dB 20 MHz: 30 dB 80 MHz: 30 dB
Noise (Probe)	100X: <15 mV _{rms} 1000X: <85 mV _{rms} (referred to input)	50X: <30 mV _{rms} 500X: <150 mV _{rms} (referred to input)	50X: <30 mV _{rms} 500X: <150 mV _{rms} (referred to input)
Environmental			
Temperature (Operating)	0°C to 50°C		
Temperature (Non-Operating)	-40°C to 70°C		
Humidity (Operating)	5% to 80% RH (Non-Condensing) up to 30°C, decreasing linearly to 45% RH at 50°C		
Humidity (Non-Operating)	5% to 95% RH (Non-Condensing), 75% RH above 30°C, 45% RH above 40°C		
Altitude (Operating)	3000 m maximum When used with clip accessories, 2000 m maximum		
Altitude (Non-Operating)	10,000 m		
Pollution Degree	2, Indoor use only		
Certifications			
CE (LVD Directive 2006/95/EC)	IEC/EN 61010-031:2015		
CE (EMC Directive 2004/108/EC)	IEC/EN 61326-1:2013		
UL Listed	UL 61010-031 (Second Edition)		
cUL Listed	CAN/CSA-C22.2 No. 61010-031-15		

SPECIFICATIONS

	HVD3206A	HVD3206A-6M	HVD3605A
Bandwidth	120 MHz	80 MHz	100 MHz
Rise Time (10-90)	2.9 ns	4.4 ns	4.3 ns
Differential Voltage Range (High Attenuation)	2000 V (DC + peak AC) from 7 to 500 V/div with up to 1500V offset.	2000 V (DC + peak AC) from 7 to 500 V/div with up to 1500V offset.	7000 V (DC + peak AC) from 28V/div to 2000 V/div with up to 6000V offset. (7600 V maximum measurable differential voltage before saturation)
Differential Voltage Range (Low Attenuation)	27.6 V (DC + peak AC) from 100 mV/div to 6.9 V/div with up to 150V offset.	27.6 V (DC + peak AC) from 100 mV/div to 6.9 V/div with up to 150V offset.	700 V (DC + peak AC) from 300mV/div to 27.5 V/div with up to 600V offset.
Common Mode Voltage Range	±2000 V (DC + peak AC)	±2000 V (DC + peak AC)	±7600V (DC + peak AC), 6000 Vrms
Maximum Input Voltage to Earth	±2000 Vpk (nominal, either input to ground)	±2000 Vpk (nominal, either input to ground)	±7600 Vpk (nominal, either input to ground)
Max Safe Input Voltage	2000 V (DC + peak AC) CAT I * 1500 Vdc CAT III 1000 Vrms CAT III	2000 V (DC + peak AC) CAT I * 1500 Vdc CAT III 1000 Vrms CAT III	8485 V (DC + peak AC) CAT I * 6000 Vrms CAT I * 1500 Vdc CAT III 1000 Vrms CAT III
Sensitivity	100 mV/div to 6.9V/div (50X) 7V/div to 500V/div (500X)	100 mV/div to 6.9V/div (50X) 7V/div to 500V/div (500X)	300 mV/div to 27.5 V/div (200X) 28 V/div to 2000 V/div (2000X)
Gain Accuracy		1% (LF, guaranteed)	
Slew Rate	400 V/ns (maximum)	270 V/ns (maximum)	1000 V/ns (typical)
Attenuation	50x / 500x	50x / 500x	200x / 2000x
Input Impedance	10 MΩ 2.5 pF (between inputs) 5 MΩ 5.0 pF (either input to ground)	10 MΩ 2.5 pF (between inputs) 5 MΩ 5.0 pF (either input to ground)	48 MΩ 2.5 pF (between inputs) 24 MΩ 5.0 pF (either input to ground)
Input Coupling		DC only	
Output Coupling		AC or DC coupling	
Output Termination		1 MΩ	
Interface		ProBus	
Input Lead Length		40 cm input lead length	
Cable Length (input lead to oscilloscope connection)	2.25 m	6.8 m	6.8 m
Noise and Rejection			
CMRR (Typical)	DC - 60 Hz: 85 dB 1 MHz: 65 dB 5 MHz: 40 dB 20 MHz: 30 dB 100 MHz: 30 dB	DC - 60 Hz: 85 dB 1 MHz: 65 dB 5 MHz: 40 dB 20 MHz: 30 dB 100 MHz: 30 dB	DC - 60 Hz: 85 dB 10 kHz: 70 dB 1 MHz: 64 dB (200x) 1 MHz: 50 dB (2000x) 10 MHz: 40 dB (200x) 10 MHz: 30 dB (2000x) 100 MHz: 30 dB
Noise (Probe)	50X: <30 mVrms 500X: <150 mVrms (referred to input)	50X: <30 mVrms 500X: <150 mVrms (referred to input)	200x: <65 mVrms 2000x: <320 mVrms (typical, referred to input)
Environmental			
Temperature (Operating)		0°C to 50°C	
Temperature (Non-Operating)		-40°C to 70°C	
Humidity (Operating)		5% to 80% RH (Non-Condensing) up to 30°C, decreasing linearly to 45% RH at 50°C	
Humidity (Non-Operating)		5% to 95% RH (Non-Condensing), 75% RH above 30°C, 45% RH above 40°C	
Altitude (Operating)		3000 m maximum When used with clip accessories, 2000 m maximum	
Altitude (Non-Operating)		10,000 m	
Pollution Degree		2, Indoor use only	
Certifications			
CE (LVD Directive 2006/95/EC)		IEC/EN 61010-031:2015	
CE (EMC Directive 2004/108/EC)		IEC/EN 61326-1:2013	
UL Listed		UL 61010-031 (Second Edition)	
cUL Listed		CAN/CSA-C22.2 No. 61010-031-15	

* CAT I per IEC/EN 61010-031/A1:2008. No Rated Measurement Category per IEC/EN 61010-031:2015.

ORDERING INFORMATION

Product Description

1 kV, 25 MHz High Voltage Differential Probe with 2 m cable
1 kV, 120 MHz High Voltage Differential Probe with 2 m cable
1 kV, 80 MHz High Voltage Differential Probe with 6 m cable
1 kV, 25 MHz High Voltage Differential Probe with 2 m cable without tip Accessories
1 kV, 120 MHz High Voltage Differential Probe with 2 m cable without tip Accessories
2 kV, 120 MHz High Voltage Differential Probe with 2 m cable
2 kV, 80 MHz High Voltage Differential Probe with 6 m cable
6 kV, 100 MHz High Voltage Differential Probe with 6 m cable
High Voltage Replacement Accessories Kit (Includes 2 each, 1 Black, 1 Red): Safety Alligator Clips, Plunger Pincer Clips, Plunger Hook Clips, Plunger Alligator Clips, Spade Terminals

Product Code

HVD3102A
HVD3106A
HVD3106A-6M
HVD3102A-NOACC
HVD3106A-NOACC
HVD3206A
HVD3206A-6M
HVD3605A
PK-HV-001

HVD310xA-NOACC

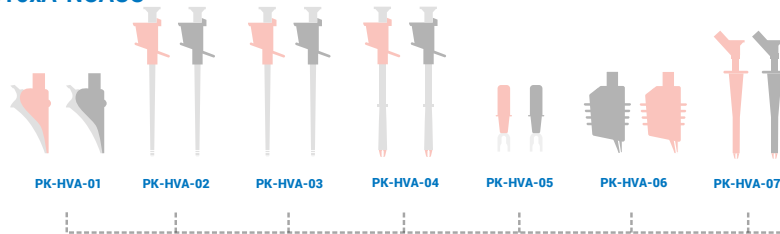

HVD310xA / 310xA-6M

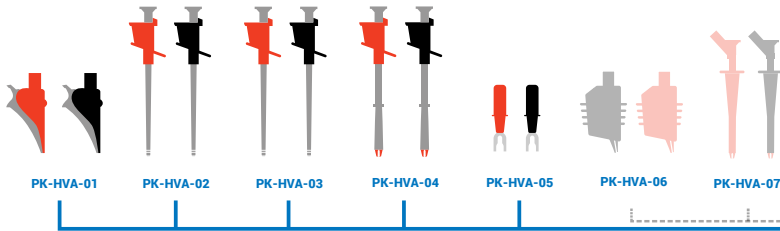

HVD3206A / 3206A-6M

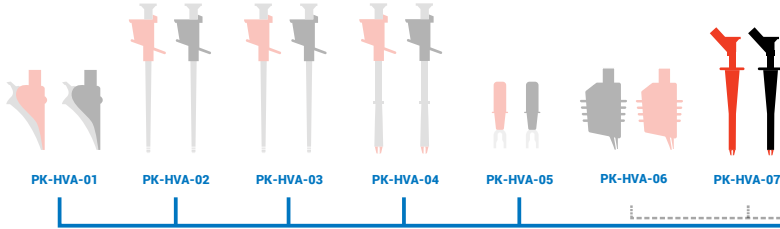

HVD3605A

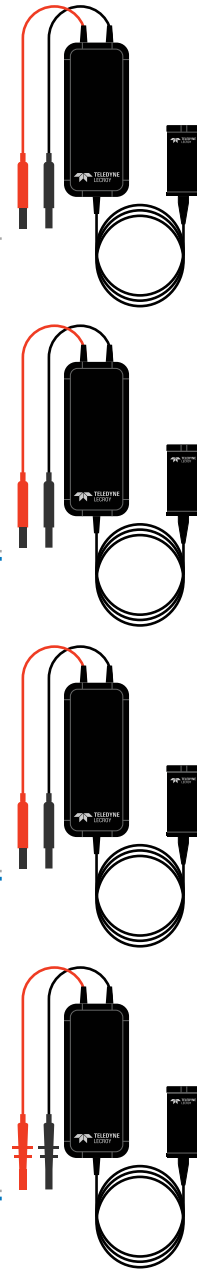
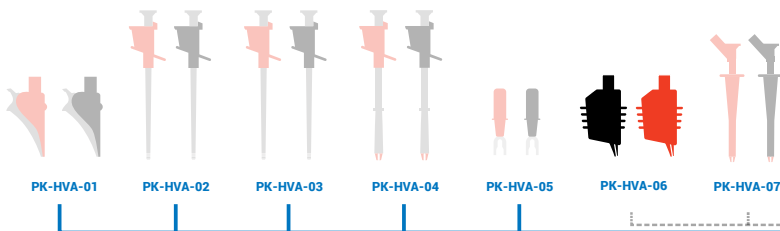

HVD-A Probe Accessories

PK-HVA-01
Safety Alligator Clips
(Red/Black)
1000 V CAT III

PK-HVA-02
Plunger Pincer Clips
(Red/Black)
1000 V CAT II

PK-HVA-03
Plunger Hook Clips
(Red/Black)
1000 V CAT II

PK-HVA-04
Plunger Alligator Clips
(Red/Black)
1000 V CAT III

PK-HVA-05
Spade Terminals
(Red/Black)
1000 V CAT III

PK-HVA-06
6 kV Safety Alligator Clips
(Red/Black)
6000 V CAT I

PK-HVA-07
2 kV Plunger Alligator Clips
(Red/Black)
2000 V CAT I

Customer Service

Teledyne LeCroy oscilloscopes and probes are designed, built, and tested to ensure high reliability. In the unlikely event you experience difficulties, our digital oscilloscopes are fully warranted for three years and our probes are warranted for one year. This warranty includes:

- No charge for return shipping
- Long-term 7-year support
- Upgrade to latest software at no charge



1-800-5-LeCroy
teledyneleeroy.com

Local sales offices are located throughout the world.
Visit our website to find the most convenient location.