



Chipsmall Limited consists of a professional team with an average of over 10 year of expertise in the distribution of electronic components. Based in Hongkong, we have already established firm and mutual-benefit business relationships with customers from,Europe,America and south Asia,supplying obsolete and hard-to-find components to meet their specific needs.

With the principle of "Quality Parts,Customers Priority,Honest Operation,and Considerate Service",our business mainly focus on the distribution of electronic components. Line cards we deal with include Microchip,ALPS,ROHM,Xilinx,Pulse,ON,Everlight and Freescale. Main products comprise IC,Modules,Potentiometer,IC Socket,Relay,Connector.Our parts cover such applications as commercial,industrial, and automotives areas.

We are looking forward to setting up business relationship with you and hope to provide you with the best service and solution. Let us make a better world for our industry!



Contact us

Tel: +86-755-8981 8866 Fax: +86-755-8427 6832

Email & Skype: info@chipsmall.com Web: www.chipsmall.com

Address: A1208, Overseas Decoration Building, #122 Zhenhua RD., Futian, Shenzhen, China



Spartan-3 Generation FPGAs



Lowest Total Cost...Period.

The World's Most Widely Adopted Low-Cost FPGAs



ONE GENERATION – MULTIPLE DOMAIN

All the Choice You Need to Solve Any Design Challenge

With the introduction of the Spartan™-3AN and Spartan-3A DSP platforms, the Spartan-3 Generation of FPGAs now offers a choice of five platforms, each delivering a unique cost-optimized balance of programmable logic, connectivity, and dedicated hard IP for your low-cost applications.

Mainstream

- Broad range of densities, general functionality and targeted specific application solutions
- Lower total system cost while increasing functionality

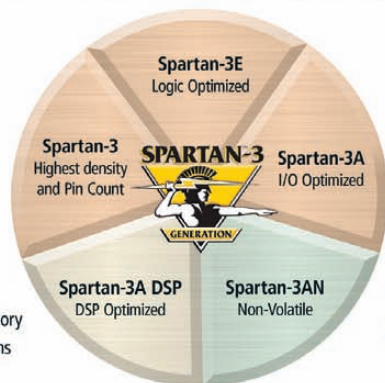

DSP

- Integrated DSP MACs and expanded memory
- Optimized for signal processing applications

Non-Volatile

- Combines leading-edge technology FPGAs & Flash technologies
- New evolution in security, protection and functionality

Mainstream FPGAs

Multiple platforms — Each optimized to a specific application domain for lowest system cost

- **Spartan-3A platform** — For applications where I/O count and capabilities matter more than logic density
 - Ideal for bridging, differential signaling and memory interfacing applications
- **Spartan-3E platform** — For applications where logic densities matter more than I/O count
 - Ideal for logic integration, DSP co-processing and embedded control
- **Spartan-3 platform** — For applications where both high logic density and high I/O count are important
 - Ideal for highly integrated data-processing applications

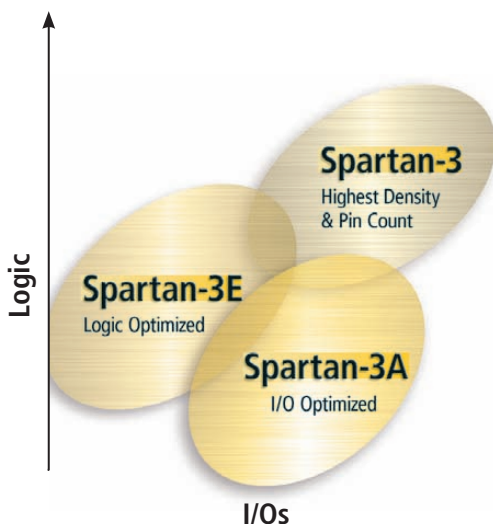

-OPTIMIZED PLATFORMS

Non-Volatile FPGAs

Non-Volatile Secure FPGAs for Highest System Integration

- **Spartan-3AN Platform** — For applications where non-volatile system integration, security or large user Flash is required
- Breakthrough marriage of uncompromised SRAM FPGA and Flash technologies
- Outperforms non-volatile FPGAs with unparalleled Flash reliability combined with performance and features previously available only in SRAM FPGAs
- Industry-leading security helps prevent reverse engineering, cloning, and unauthorized overbuilding
- Superior system flexibility with up to 11 Mb of on-chip user Flash

Digital Signal Processing FPGAs

Breakthrough Price for High Performance DSP

- **Spartan-3A DSP Platform** — For applications where integrated DSP MACs and expanded memory are required
- Supports high-density designs with up to 53K logic cells and robust on-chip memory
- Over 20 GMACS DSP performance for under \$30 utilizing cost-optimized integrated DSP48A slices
- Ideal for designs requiring low-cost FPGAs for signal processing applications such as military radio, surveillance cameras, medical imaging, etc.
- Significant gains in application efficiency using highly parallel architectures

Delivering the Best of Both Worlds

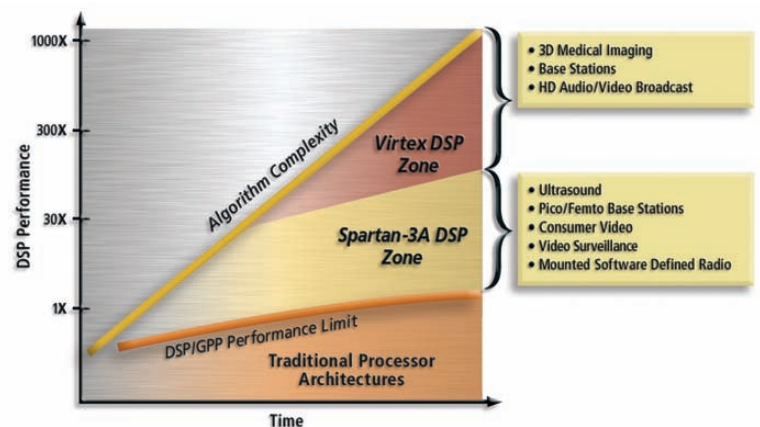
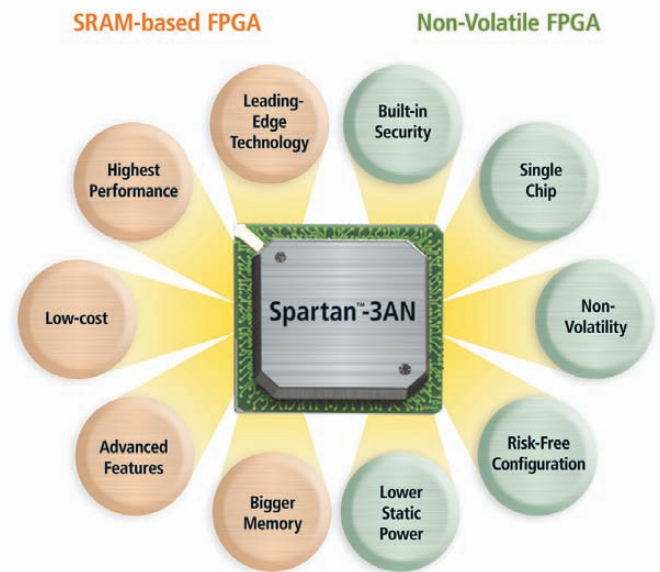

Algorithmic Complexity – As demand for processing power rapidly increases, sequential processing cannot support algorithmic complexities within required response times. To overcome these architectural limitations, the parallel processing offered by Virtex™ DSP and Spartan™ DSP FPGAs is essential.

THE LOWEST TOTAL-COST.

Up to 50% Lower Total Cost

Lowest cost devices for your application

- Industry's largest selection of low-cost devices and packages
- Allows an optimal match for any customer requirement
- Small form-factor packages for extremely cost-sensitive consumer applications

Reduced Bill of Materials cost

- High on-chip integration reduces number of external components including voltage regulators, buffers, and line drivers
- More tolerant Vcc specification allows use of inexpensive voltage regulators
- Noise-resistant circuits eliminate or minimize need for expensive filtering components such as ferrite beads and decoupling capacitors

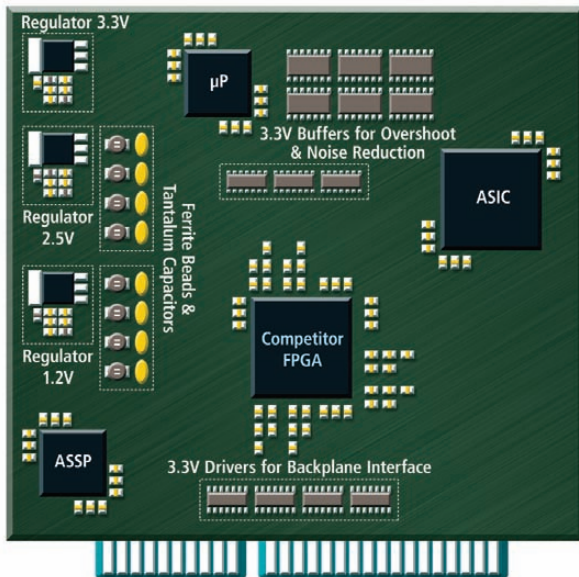

Competitive Solution

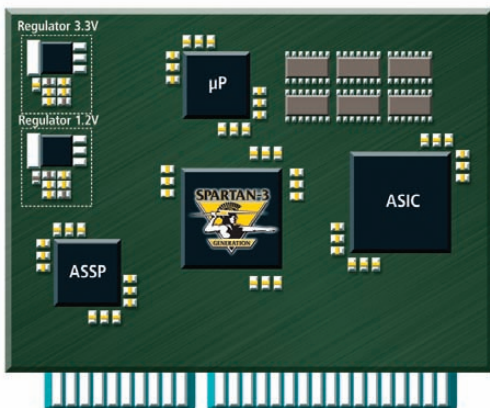

Spartan Low-cost Solution



Cost-effective engineering design

- Fewer components simplify and shrink board designs
- Comprehensive IP library (8X bigger than nearest competitor), extensive portfolio of boards/kits and software tools significantly reduce time-to-market

Lower Inventory and manufacturing costs

- Fewer components minimize ordering, reduce material holding cost, and simplify logistics
- Use of standard components allow reuse of excess inventory

Improved quality and reliability

- Decreased PCB complexity with fewer components, lower layer count and increased signal integrity
- Reduced device count significantly decreases failures from misalignment and cold solder joint failures, etc.

PERIOD.



Lower Power, Lower Cost

On-chip power management

- No complex design requirements
- Fewer external components such as heat sinks, fans, etc.
- Suspend Mode lowers static power by more than 40%
- Hibernate Mode offers maximum power savings by lowering static power by up to 99%

Industry-leading power management tools

- ISE™ 10.1 delivers automatic dynamic power reduction
- XPower analyzer tools with full environment, voltage, and worst-case evaluation

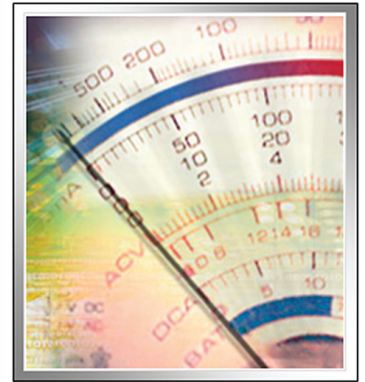

Robust, Low-cost Design Security

Helps prevent unauthorized manufacturing

- Protects revenues from cloning, overbuilding and reverse-engineering
- Design security to safeguard both hardware and software IP
- Cost-based flexible security solutions based on unique requirements
- Unique Device DNA serial number
- Customizable algorithms for security as well as responses to failures

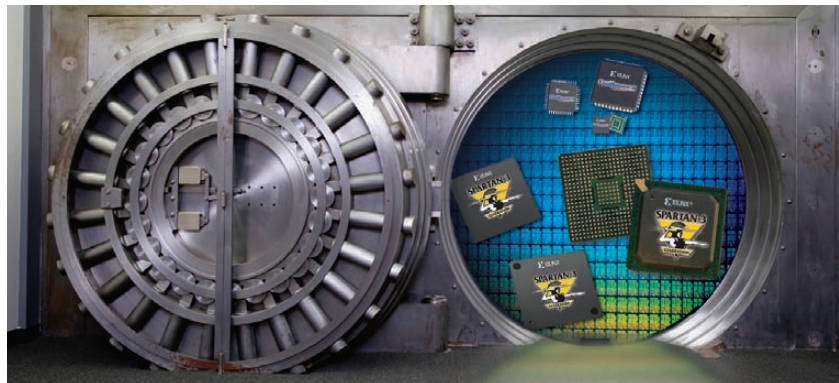

The Right Fit for the Right Application

The comprehensive portfolio of Spartan platforms allows customers to choose the best solution for their unique design requirements.

Platform	Spartan-3	Spartan-3E	Spartan-3A	Spartan-3AN	Spartan-3A DSP
Cost Optimization	High logic density and I/O count	Logic density	I/O count & Capabilities	Non-volatile Capabilities	DSP Capabilities
Ideal Applications	High logic and I/O densities—highly integrated data-processing	Lowest-cost density—logic integration, DSP co-processing, embedded control	Wide or multiple interfaces—bridging, differential signaling, memory interfaces	Space-critical or secure applications as well as low cost embedded controllers	Signal Processing applications such as military radio, cameras, medical imaging, etc.
Logic Cells	1,728 to 74,880	2,160 to 33,192	1,584 to 25,344	1,584 to 25,344	37,440 to 53,712
I/Os	63 to 633	66 to 376	108 to 502	108 to 502	309 to 519
User Flash	—	—	—	Up to 11Mb	—
Security	External with secure PROM	External with secure PROM	Internal with Device DNA	Internal with on-chip configuration, Device DNA, and Factory Flash ID	Internal with Device DNA
Power Management	<ul style="list-style-type: none"> • XPower Analyzer and Web Power Tools 	<ul style="list-style-type: none"> • XPower Estimator and XPower Analyzer Tools 	<ul style="list-style-type: none"> • Suspend—more than 40% reduction • Hibernate—up to 99% reduction • XPower Estimator and XPower Analyzer Tools 	<ul style="list-style-type: none"> • Suspend—more than 40% reduction • Hibernate—up to 99% reduction • XPower Estimator and XPower Analyzer Tools 	<ul style="list-style-type: none"> • Suspend—more than 40% reduction • Hibernate—up to 99% reduction • XPower Estimator and XPower Analyzer Tools
SelectIO™ Technology	<ul style="list-style-type: none"> • Supports 24 differential and single-ended I/O standards • Up to 24mA drive • DDR and DDR2 memory interfaces 	<ul style="list-style-type: none"> • Supports 18 differential and single-ended I/O standards • Enhanced differential signaling with on-chip termination • Up to 16mA drive • DDR memory interfaces 	<ul style="list-style-type: none"> • Supports 26 differential and single-ended I/O standards • Enhanced differential signaling with on-chip termination • TMDS, PPDS, RSDS, LVDS, DDR, DDR2 and SSTL3 class I & II • Full 3.3V and hot swap compliance 	<ul style="list-style-type: none"> • Supports 26 differential and single-ended I/O standards • Enhanced differential signaling with on-chip termination • TMDS, PPDS, RSDS, LVDS, DDR, DDR2 and SSTL3 class I & II • Full 3.3V and hot swap compliance 	<ul style="list-style-type: none"> • Supports 26 differential and single-ended I/O standards • Enhanced differential signaling with on-chip termination • TMDS, PPDS, RSDS, LVDS, DDR, DDR2 and SSTL3 class I & II • Full 3.3V and hot swap compliance
DSP Resources	<ul style="list-style-type: none"> • Embedded 18 x 18 multipliers • 18 Kbit dual-port RAM • Distributed RAM and shift registers 	<ul style="list-style-type: none"> • Pipelined, embedded 18 x 18 multipliers • 18 Kbit dual-port RAM • Distributed RAM and shift registers 	<ul style="list-style-type: none"> • Pipelined, embedded 18 x 18 multipliers • 18 Kbit dual-port RAM • Distributed RAM and shift registers 	<ul style="list-style-type: none"> • Pipelined, embedded 18 x 18 multipliers • 18 Kbit dual-port RAM • Distributed RAM and shift registers 	<ul style="list-style-type: none"> • Integrated XtremeDSP™ • DSP48A provides an 18-bit x 18-bit multiplier, 18-bit pre-adder, 48-bit post-adder/accumulator
Configuration	<ul style="list-style-type: none"> • Platform Flash, with easy in-system reprogrammability, and compression • JTAG and ISE™ tool support 	<ul style="list-style-type: none"> • Platform Flash with full support • Parallel Flash with MultiBoot • SPI Flash • JTAG and ISE tool support 	<ul style="list-style-type: none"> • Platform Flash with full support • Parallel Flash with MultiBoot plus watchdog • SPI Flash • JTAG and ISE tool support 	<ul style="list-style-type: none"> • Platform Flash with full support • Parallel Flash with MultiBoot plus watchdog • SPI Flash • JTAG and ISE tool support 	<ul style="list-style-type: none"> • Platform Flash with full support • Parallel Flash with MultiBoot plus watchdog • SPI Flash • JTAG and ISE tool support

FAST, FLEXIBLE SYSTEM

Implement Customizable Low-Cost Solutions with Pre-Engineered IP

Optimized silicon and application-specific IP enables optimized solutions with popular low-cost interface standards.

PCI Express®

- Fully-compliant to PCIe® Specification v1.1
- Starter Kit for PCI Express including development board
- LogiCORE™ PIPE Endpoint for PCI Express
- Reference Design with third-party PHY
- Bundled solution pricing

PCI™ 33 and 66MHz, fully PCI 3.0-compliant

- PCI32 and PCI64 LogiCORE IP cores
- Customizable back-end functionality

Ethernet

- Designed to the IEEE 802.3-2002 specification for 1000 Mbps, 100 Mbps, and 10 Mbps modes
- Customizable LogiCORE Tri-Mode Ethernet MAC
- Integrates with the Ethernet 1000BASE-X PCS/PMA or SGMII LogiCORE for implementation of Ethernet Link and Physical layers
- Trimode Ethernet MAC and Ethernet Lite Peripherals for Embedded Processing Applications

DSP

- FEC blocks including Viterbi, Reed Solomon, Convolution Encoder and standard specific IP blocks such as WIMAX, W-CDMA, DOCSIS
- Video Codecs: MPEG4, H.264, etc.

Embedded Processing

- Customizable 32-bit MicroBlaze™ soft processor with complete set of Peripheral IP cores
- Platform Studio tool suite simplifies embedded processing system design
- Comprehensive embedded software tools & RTOS ecosystem providers
- Small footprint PicoBlaze for 8-bit controller for assembly programmed applications

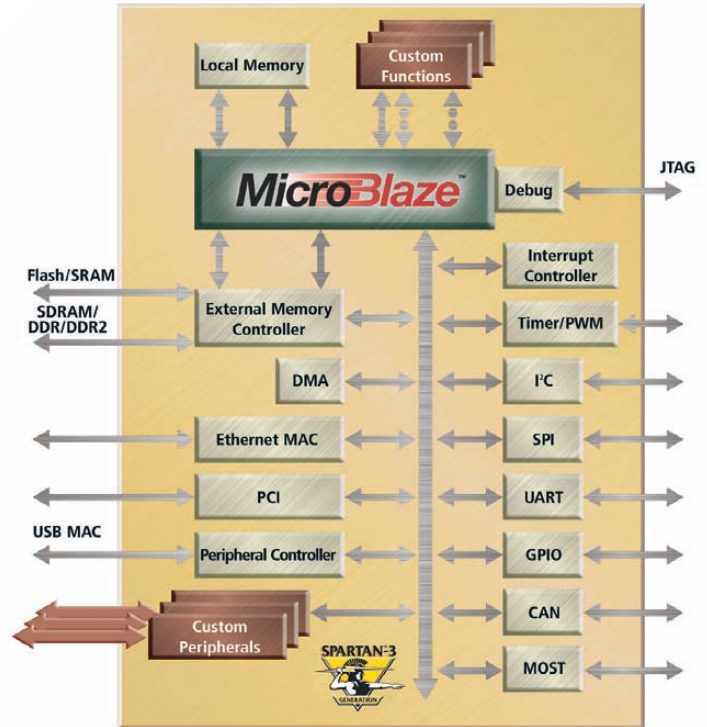

SPI-4.2, functionally compliant with OIF and SATURN® specifications

- SPI4.2(PL4) Lite LogiCORE delivers Sink and Source cores selected and configured through Xilinx CORE Generator™

CAN, designed to ISO 11898-1, CAN2.0A and CAN2.0B specifications

- User-configurable CAN LogiCORE IP
- Stand-alone mode or connected to Xilinx MicroBlaze processor

Memory Interfaces

Dynamic Input Delay Technology and the Memory Interface Generator tool make it easy to build reliable interfaces to the latest low-cost memories, including DDR2 and DDR

Memory Device	Electrical Interface	Clock Rate	Data Rate
DDR2 SDRAM	SSTL 1.8V	200 MHz	400 Mbps
DDR SDRAM	SSTL 2.5V	166 MHz	333 Mbps

Over 300 IP Blocks Available Today – www.xilinx.com/ipcenter

INTEGRATION

Accelerate Time-to-Market with Development Boards and Starter Kits

The Spartan boards and Starter Kits provide a complete development solution giving designers instant access to the capabilities of the Spartan FPGAs. The Starter Kit includes a development board, power supply with universal adaptors, and much more.

Board/Kit	Part numbers	Price
Spartan-3AN Starter Kit	HW-SPAR3AN-SK-UNI-G	\$199
Spartan-3A Starter Kit	HW-SPAR3A-SK-UNI-G	\$189
Spartan-3E Starter Kit	HW-SPAR3E-SK-UNI-G	\$149
Spartan-3 Starter Kit	HW-SPAR3-SK-UNI-G	\$149
Spartan-3A DDR2 SDRAM Interface Development Kit	HW-SPAR3ADDR2-DK-UNI-G	\$235
Spartan-3E PCI Express Starter Kit	HW-S3PCIE-DK	\$349
Automotive ECU Development Kit	HW-XA3S1600E-UNI-G	\$1495
Spartan-3E Display Development Kit	HW-SPAR3E-DISP-DK-UNI-G	\$1595
Embedded Development HW/SW Kit – MicroBlaze Processor Edition	DO-SD1800A-EDK-DK-UNI-G	\$595
XtremeDSP Starter Platform – Spartan-3A DSP 1800A Edition	HW-SD1800A-DSP-SB-UNI-G	\$295
XtremeDSP Starter Kit – Spartan-3A DSP Edition	DO-SD1800A-DSP-SK-UNI-G-PROMO	\$495
XtremeDSP Development Board – Spartan-3A DSP 3400A Edition	HW-SD3400A-DSP-DB-UNI-G	\$995
XtremeDSP Video Starter Kit — Spartan-3A DSP Edition	DO-S3ADSP-VIDEO-SK-UNI-G	\$1595

Note: For more information on development boards, please visit www.xilinx.com/spartankits



Spartan-3A Starter Kit

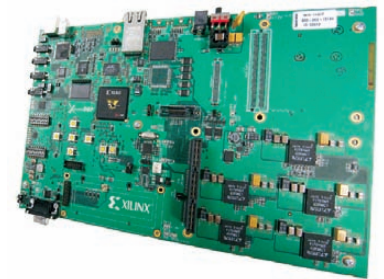

Spartan-3A DSP Development Board

Flexibility and Low Cost – The Ultimate Choice for Volume Applications

Systems designers worldwide are leveraging the unique advantages of Spartan-3 Generation FPGAs across a wide range of end applications, adapting their products to rapidly changing interface and data standards, differentiating functionality with minimum design time, and reducing risk as they ramp to higher production volumes.

Examples	Application Challenges	Spartan-3 Generation Advantages
Flat Panel Displays 	<ul style="list-style-type: none"> • Panel board and video/tuner board cost • Constantly evolving I/O requirements • Shorter product life cycles with higher amortized cost risk for new ASICs • Constantly evolving, subjective image quality requirements • Differentiating vs. competing hardware 	<ul style="list-style-type: none"> • 5 domain-optimized platforms for lowest-cost fit to each application • SelectIO Technology with on-chip differential termination and widest I/O standards compliance, including LVDS, RSDS, mini-LVDS, PPDS and TMDS • Pre- or post-processing video enhancement, LVDS TxRx (FPDLink), and peripheral interface bridging solutions • TCON (timing control) and video co-processing flexibility • Flexible peripheral interfacing and video switching • Reference designs for precise gamma correction, image dithering, color temperature correction and other video-enhancement functions
Set-Top Boxes 	<ul style="list-style-type: none"> • Evolving interface standards for memory, disks, and other components • Managing inventory with multiple product feature sets • Differentiating video processing capability at lower power and cost • Accelerating and updating algorithms for conditional access/security 	<ul style="list-style-type: none"> • SelectIO Technology with support for up to 26 different I/O standards • MultiBoot reconfigurability and density migration within a single package • XtremeDSP Technology with industry-leading price/performance for digital video decoding • Fast, compact IP cores for authentication and content encryption
Wireless Access 	<ul style="list-style-type: none"> • Low-level MAC-layer co-processing in Customer Premises Equipment • Forward Error Correction and DSP co-processing efficiency • Peripheral bridging and interfacing 	<ul style="list-style-type: none"> • IP cores for MAC, FEC, encryption, digital up/down conversion and security • XtremeDSP Technology with flexible high performance • SelectIO Technology with on-chip termination and wide I/O standards support
Industrial Ethernet and Motion Control 	<ul style="list-style-type: none"> • Bridging multiple connectivity protocols • Customizing PWM and control algorithms • Accelerating motion control algorithms 	<ul style="list-style-type: none"> • IP cores for EtherCAT, SerCOS III, CAN, Ethernet, PCI and PCI Express • Flexible Xilinx Embedded Processing Technology • Hardware acceleration with Fast Simplex Link and XtremeDSP Technology
Automotive 	<ul style="list-style-type: none"> • Full compliance to industry production process and quality standards • Interconnecting different automotive/multimedia standards 	<ul style="list-style-type: none"> • Extended Automotive temperature ranges, both Industrial and Q-Grade; full PPAP support and AEC-Q100 qualification for Spartan-3 and Spartan-3E platforms • IP cores for bridging CAN, LIN and MOST®, as well as USB 2.0 and Ethernet • XtremeDSP Technology with industry-leading price/performance/power and IP for filtering, edge detection, and codes • SelectIO Technology with on-chip termination for LVDS, RSDS and other standards
Video Surveillance 	<ul style="list-style-type: none"> • DSP performance need for object recognition, motion detection and advanced compression algorithms • Changing industry standards • Rapidly evolving technology such as automated scene analysis 	<ul style="list-style-type: none"> • XtremeDSP performance through parallelism in FPGA fabric • FPGA flexibility and scalability • Field upgradeability

TAKE THE NEXT STEP

Visit us online at www.xilinx.com/spartan

	Spartan-3 Optimized for High Density and High I/O Designs							Spartan-3E Logic optimized					Spartan-3A I/O optimized					Spartan-3AN Non-volatile					Spartan-3A DSP DSP optimized		
Part Number	XC3S50	XC3S200	XC3S400	XC3S1000	XC3S1500	XC3S2000	XC3S4000	XC3S5000	XC3S100E	XC3S250E	XC3S500E	XC3S1200E	XC3S1600E	XC3S50A	XC3S200A	XC3S400A	XC3S700A	XC3S1400A	XC3S50AN	XC3S200AN	XC3S400AN	XC3S700AN	XC3S1400AN	XC3SD1800A	XC3SD3400A
System Gates	50K	200K	400K	1000K	1500K	2000K	4000K	5000K	100K	250K	500K	1,200K	1,600K	50K	200K	400K	700K	1400K	50K	200K	400K	700K	1400K	1800K	3400K
Logic Cells	1,728	4,320	8,064	17,280	29,952	46,080	62,208	74,880	2,160	5,508	10,476	19,512	33,192	1,584	4,032	8,064	13,248	25,344	1,584	4,032	8,064	13,248	25,344	37,440	53,712
Dedicated Multipliers	4	12	16	24	32	40	96	104	4	12	20	28	36	3	16	20	20	32	3	16	20	20	32	84*	126*
Block RAM Blocks	4	12	16	24	32	40	96	104	4	12	20	28	36	3	16	20	20	32	3	16	20	20	32	84	126
Block RAM Bits	72K	216K	288K	432K	576K	720K	1,728K	1,872K	72K	216K	360K	504K	648K	54K	288K	360K	360K	576K	54K	288K	360K	360K	576K	1512K	2268K
Distributed RAM Bits	12K	30K	56K	120K	208K	320K	432K	520K	15K	38K	73K	136K	231K	11K	28K	56K	92K	176K	11K	28K	56K	92K	176K	260K	373K
DCMs	2	4	4	4	4	4	4	4	2	4	4	8	8	2	4	4	8	8	2	4	4	8	8	8	8
User Flash Bits																			627K	2M	2M	5M	11M		
Max Single Ended I/O	124	173	264	391	487	565	633	633	108	172	232	304	376	144	248	311	372	502	108	195	311	372	502	519	469
Max Diff. I/O Pairs	56	76	116	175	221	270	300	300	40	68	92	124	156	64	112	142	165	227	50	90	142	165	227	227	213
VQ100 16 x 16 mm	63	63							66	66				68	68										
CP132 8 x 8 mm	89								83	92	92														
TQ144 22 x 22 mm	97	97	97						108	108				108					108						
PQ208 30.6 x 30.6 mm	124	141	141							158	158														
FT256 17 x 17 mm		173	173	173						172	190	190		144	195	195	161	161		195					
FG320 19 x 19 mm			221	221	221						232	250	250		248	251									
FG400 21 x 21 mm												304	304			311	311				311				
FG456 23 x 23 mm			264	333	333	333																			
FG484 23 x 23 mm													376				372	375				372			
CS484 19 x 19 mm																							309	309	
FG676 27 x 27 mm				391	487	489	489	489										502					502	519	469
FG900 31 x 31 mm						565	633	633																	

Note: 1. System Gates include 20-30% of CLBs used as RAMs.

2. Numbers in table across device packages indicate maximum number of user I/Os.

3. For detailed information on device and package offerings, please check the data sheet for the specific platform at www.xilinx.com/spartan

* Integrated in the DSP48A slices (Advanced Multiply Accumulate Element)

Corporate Headquarters

Xilinx, Inc.
2100 Logic Drive
San Jose, CA 95124
USA

Tel: +1-408-559-7778
Web: www.xilinx.com

Europe

Xilinx Europe
One Logic Drive
Citywest Business Campus
Saggart, County Dublin
Ireland

Tel: +353-1-464-0311
Web: www.xilinx.com

Japan

Xilinx K.K.
Art Village Osaki Central Tower 4F
1-2-2 Osaki, Shingawa-ku
Tokyo 141-0032 Japan
Tel: +81-3-6744-7777
Web: japan.xilinx.com

Asia Pacific Pte. Ltd.

Xilinx, Asia Pacific
5 Changi Business Park
Singapore 486040
Tel: +65-6407-3000
Web: www.xilinx.com

www.xilinx.com



PB-free devices
available now

©2008 Xilinx, Inc. All rights reserved. XILINX, the Xilinx logo, are either registered trademarks or trademarks of Xilinx, Inc. All other trademarks are the property of their respective owners.