



Chipsmall Limited consists of a professional team with an average of over 10 year of expertise in the distribution of electronic components. Based in Hongkong, we have already established firm and mutual-benefit business relationships with customers from,Europe,America and south Asia,supplying obsolete and hard-to-find components to meet their specific needs.

With the principle of "Quality Parts,Customers Priority,Honest Operation,and Considerate Service",our business mainly focus on the distribution of electronic components. Line cards we deal with include Microchip,ALPS,ROHM,Xilinx,Pulse,ON,Everlight and Freescale. Main products comprise IC,Modules,Potentiometer,IC Socket,Relay,Connector.Our parts cover such applications as commercial,industrial, and automotives areas.

We are looking forward to setting up business relationship with you and hope to provide you with the best service and solution. Let us make a better world for our industry!



## Contact us

Tel: +86-755-8981 8866 Fax: +86-755-8427 6832

Email & Skype: info@chipsmall.com Web: www.chipsmall.com

Address: A1208, Overseas Decoration Building, #122 Zhenhua RD., Futian, Shenzhen, China



# LEADED CERAMIC RESONATOR

HWZT-MD

RoHS/RoHS II Compliant  
Pb in ceramic, exemption (7c-I)



## FEATURES:

- Low resonant impedance
- Small size, Light weight.
- Low cost timing solution

## APPLICATIONS:

- Clock oscillation for microcontrollers
- Telephones
- Household electric appliances

## STANDARD SPECIFICATIONS:

Parameters	Minimum	Typical	Maximum	Units	Notes
Frequency Range	2.00		6.00	MHz	
	12.51		60.00		
Resonant Impedance (Ro)			80	Ω	2.00 MHz ~ 2.99 MHz
			30		3.00 MHz ~ 6.00 MHz
			30		12.51 MHz ~ 60.00 MHz
Standard Load Capacitance for test circuit (C1=C2)	24	30	36	pF	2.00 MHz ~ 6.00 MHz
	24	30	36		12.51 MHz ~ 20.00 MHz
	12	15	18		20.01 MHz ~ 25.99 MHz
	4	5	6		26.00 MHz ~ 60.00 MHz
Frequency Tolerance	-0.5		+0.5	%	
Frequency Stability	-0.3		+0.3	%	-25°C to +85°C
Withstanding Voltage			50	Vdc	DC , 1 min
Rating Voltage	D.C. Voltage		6	Vdc	
	A.C. Voltage		15	Vp-p.	
Insulation Resistance	100			MΩ	10Vdc, 1min
Operation Temperature	-25		+85	°C	
Storage Temperature	-55		+85	°C	
Aging Rate (Fosc)	-0.3		0.3	%	From initial value

## TEST CONDITION AND TEST CIRCUIT:

## OPTIONS & PART IDENTIFICATION:

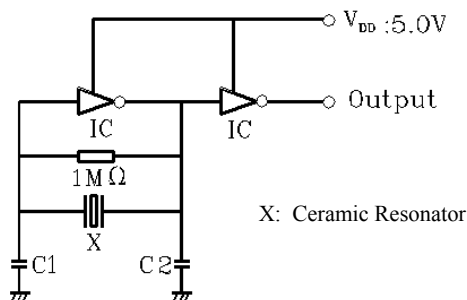

Parts shall be measured under a condition (Temp.: 20±15°C, Humidity: 65±20% R.H.) unless the standard condition (Temp.: 25±2°C, Humidity: 65±5% R.H.) is regulated to measure

HWZT - [ ] MD - [ ]

### Frequency

Frequency in MHz

### Packaging

Blank: Bulk

A: AMMO package\*

\*AMMO package  
lead length 13.5mm

# LEADED CERAMIC RESONATOR

HWZT-MD

RoHS/RoHS II Compliant  
Pb in ceramic, exemption (7c-I)



## OUTLINE DRAWING:

**Freq. Range: 2.00 ~ 6.00MHz (Low Profile)**

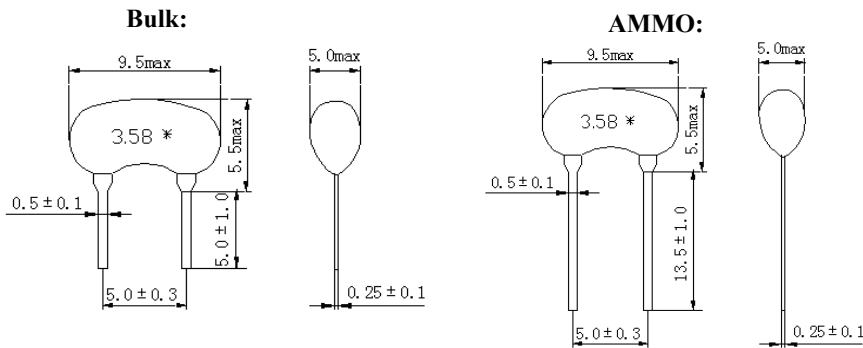

**Freq. Range: 12.51 ~ 60.00MHz**

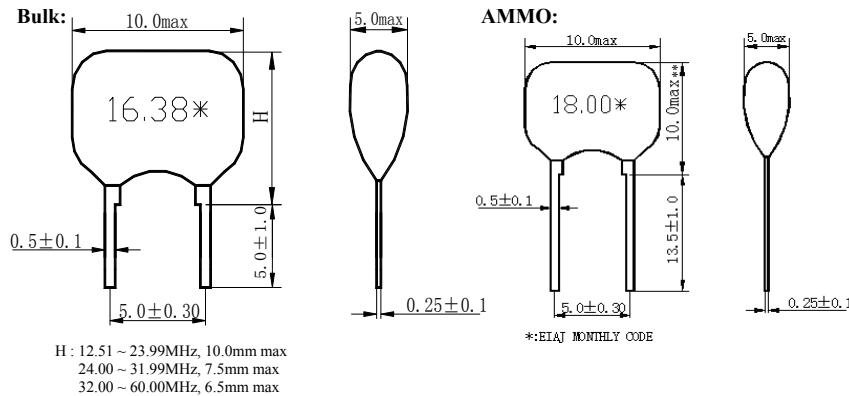

Dimension: mm

## Packaging:

**Bulk:** 500pcs/plastic bag

**AMMO:** 2000pcs/box

**Note:** upon opening the original packaging, it is recommended that the product be used within 1 year. If the product will not be used within 1 year, it is recommended that the product be re-sealed in airtight packaging according to MSL 1 requirements to maintain solderability.

## CAUTION

- (1) Do not apply excess mechanical stress to the component body or terminations. Do not attempt to re-form or bend the components as this will cause damage to the component.
- (2) This component is not hermetically sealed. Do not clean or wash the component.
- (3) Reflow Soldering: Do not use strong acidity flux, such as flux with chlorine content of greater than 0.2wt% during Reflow Soldering.
- (4) Do not expose the component to open flame.
- (5) This specification applies to the functionality of the component as a single unit.
- (6) Storage Conditions: If the product is to be stored for a period greater than 1 year after the Delivery Date, it is recommended that customers confirm the solderability and characteristics for the product prior to use.
- (7) This product is not recommended for use in the following applications: Automotive, Medical, Military, Safety, or any other high-reliability life dependant applications. Contact Abracon Corporation prior to using this product when in doubt.

**ATTENTION:** Abracon Corporation's products are COTS – Commercial-Off-The-Shelf products; suitable for Commercial, Industrial and, where designated, Automotive Applications. Abracon's products are not specifically designed for Military, Aviation, Aerospace, Life-dependant Medical applications or any application requiring high reliability where component failure could result in loss of life and/or property. For applications requiring high reliability and/or presenting an extreme operating environment, written consent and authorization from Abracon Corporation is required. Please contact Abracon Corporation for more information.

ABRACON IS  
ISO9001:2008  
CERTIFIED



Visit [www.abracon.com](http://www.abracon.com) for Terms & Conditions of Sale  
30332 Esperanza, Rancho Santa Margarita, California 92688  
tel 949-546-8000 | fax 949-546-8001 | [www.abracon.com](http://www.abracon.com)

Revised: 05.07.13