



Chipsmall Limited consists of a professional team with an average of over 10 year of expertise in the distribution of electronic components. Based in Hongkong, we have already established firm and mutual-benefit business relationships with customers from,Europe,America and south Asia,supplying obsolete and hard-to-find components to meet their specific needs.

With the principle of "Quality Parts,Customers Priority,Honest Operation,and Considerate Service",our business mainly focus on the distribution of electronic components. Line cards we deal with include Microchip,ALPS,ROHM,Xilinx,Pulse,ON,Everlight and Freescale. Main products comprise IC,Modules,Potentiometer,IC Socket,Relay,Connector.Our parts cover such applications as commercial,industrial, and automotives areas.

We are looking forward to setting up business relationship with you and hope to provide you with the best service and solution. Let us make a better world for our industry!



Contact us

Tel: +86-755-8981 8866 Fax: +86-755-8427 6832

Email & Skype: info@chipsmall.com Web: www.chipsmall.com

Address: A1208, Overseas Decoration Building, #122 Zhenhua RD., Futian, Shenzhen, China



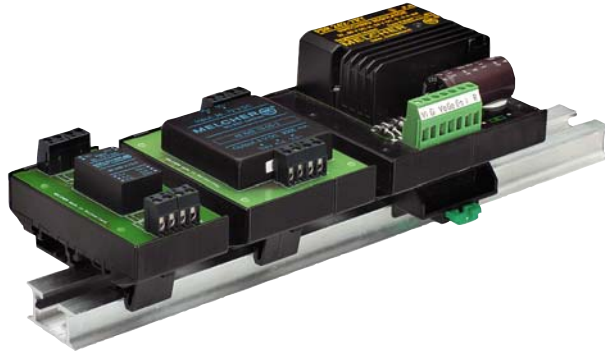

Description

Special mounting supports have been designed for the integration of power supplies into switch boards, control panels, printed circuit boards, etc., using adapters for chassis-, DIN-rail, or PCB mounting.

The 19-inch cassette type DC-DC and AC-DC converters can also be chassis mounted with frontal access by means of a special *Chassis Mounting Plate*, attached to the converters.

The *Universal Mounting Bracket* also fits to most of these cassette type converters, allowing for either vertical chassis or DIN-rail mounting.

A *Bracket Kit*, consisting of a PCB with screw terminal connectors and a bracket suitable for either chassis- or DIN-rail mounting, is available either for PCB mountable PSR and PSA Switching Regulators with option "Y" pins or for small DC-DC converters 1 – 15 Watt.

For isolation of the PCB-mountable converters from a double sided PCB, the use of *Isolation Pads* is recommended, as described below.

Note: All dimensions are in mm, unless otherwise specified.

Table of Contents

	Page		Page
Description	1	Universal Mounting Bracket	9
Chassis Mounting Plates	2	Isolation Tags for PCB Mounting	11
DIN- and Chassis Mounting Brackets	4	PCB Tags for PCB Mounting	11

Chassis Mounting Plates

For chassis mounting of 19" cassette-style converters, where only frontal access to the mounting screws is given, special chassis mounting plate adapters are available according to the following table and figures 1 to 3.

Table 1: Mounting Plate survey

Case size	Converter series	Type Item no.	Delivery content
K02	K ¹ , PSK ¹	Mounting plate K02	Mounting plate, 4 countersunk screws
S02	S ¹ , PSS ¹		
Q01	Q	Mounting plate Q	
Q03	LPC		
Q04	P		
Q01	Q	Mounting plate M	Mounting plate, 4 countersunk screws, 4 washers
Q03	LPC		
Q04	P		
M02	M		
H02	H		

¹ Option B1 necessary

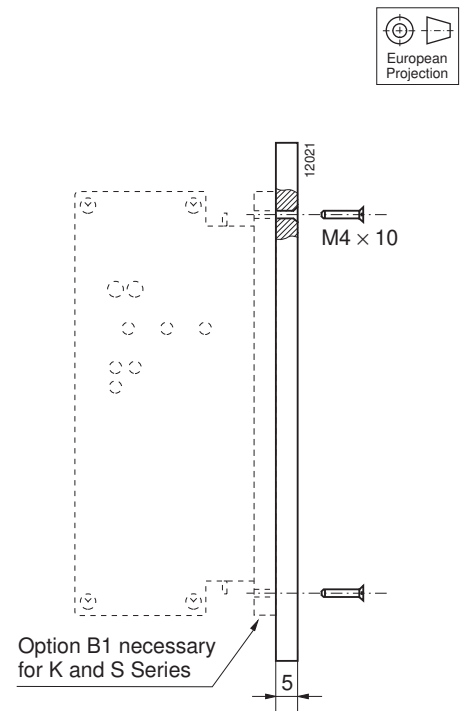
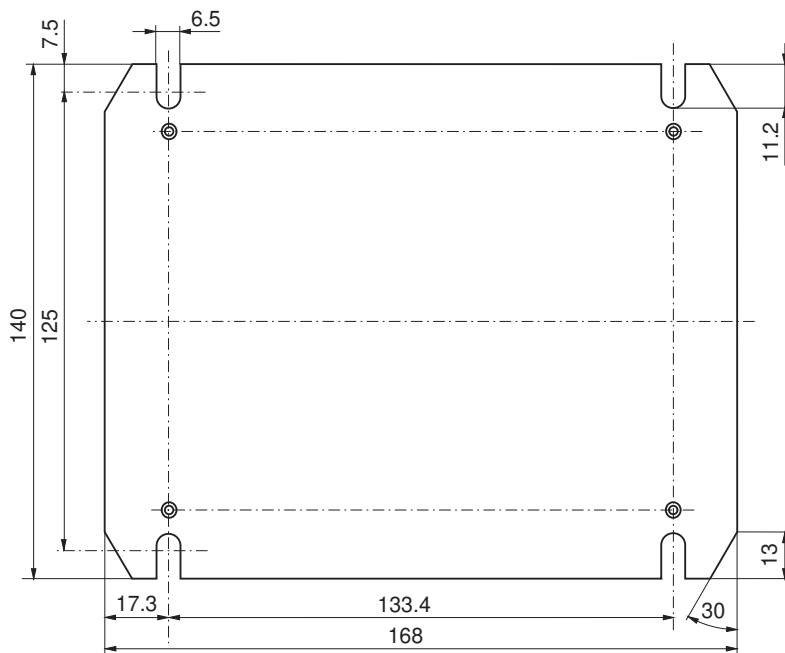

Fig. 1
Mounting plate K02
Aluminium, black finish

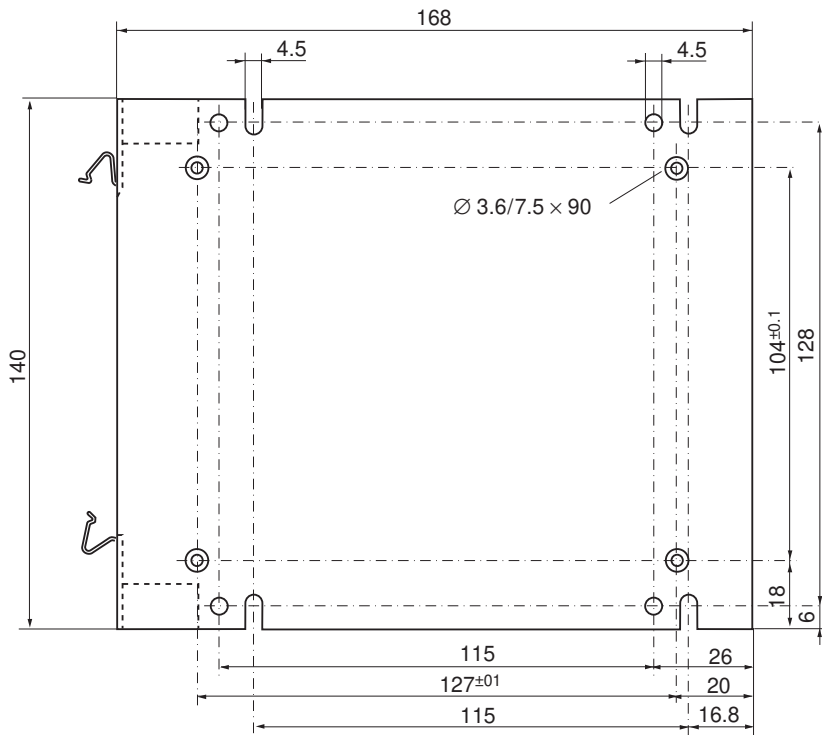

Fig. 2a
Mounting plate Q with integrated connector retention facility
using the Retention Clip [HZZ01209]
Aluminium, black finish

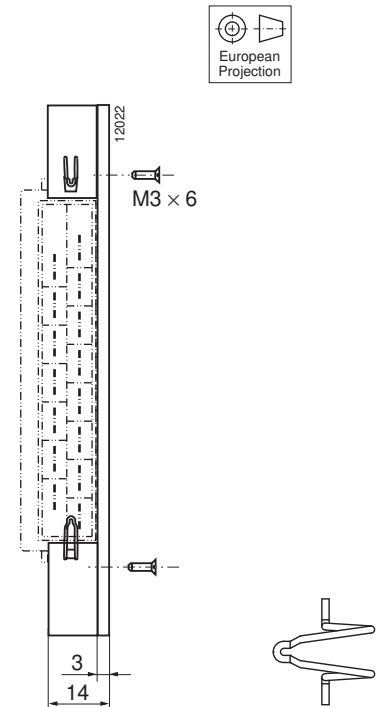

Fig. 2b
Retention Clip
[HZZ01209]

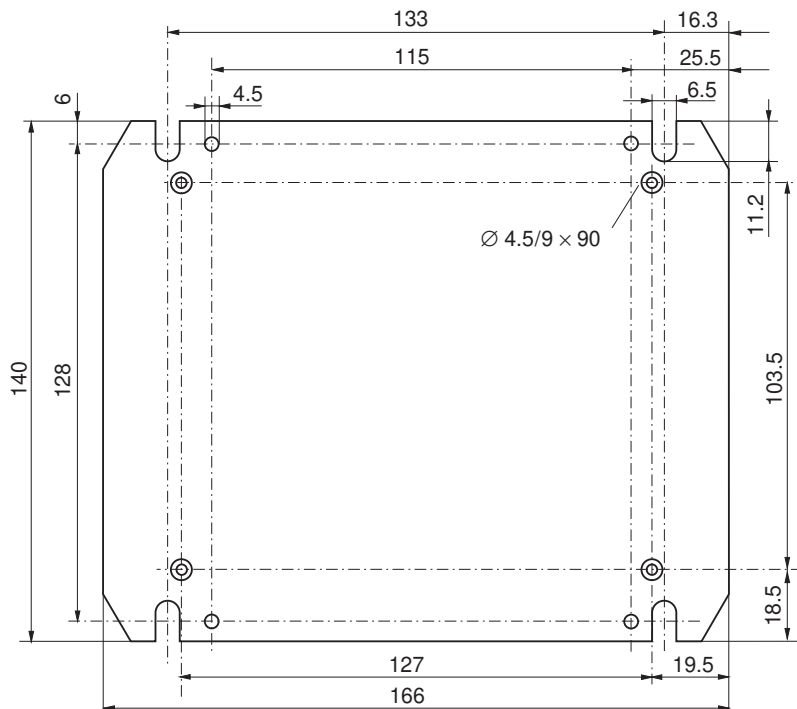
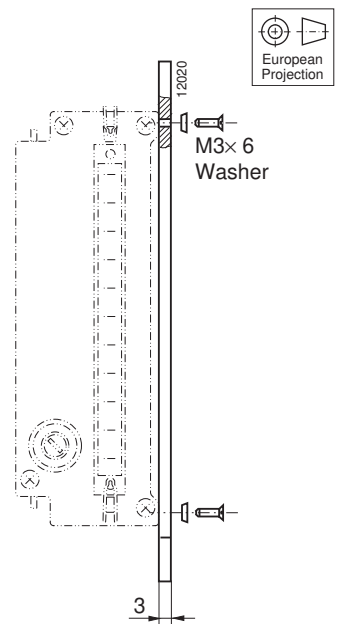

Fig. 3
Mounting plate M
Aluminium, black finish



DIN- and Chassis Mounting Brackets

PCB mounting as well as cassette style converters can be chassis- and/or DIN-Rail mounted by means of Mounting Bracket adapters. For selection and item numbers refer to table below.

Note: Customized adapters for other case sizes are available upon request.

Each item number gives a direct indication of the kind of mounting, the type of converter, i.e. the case size, or the output power as well as the possible pinnings and options according to the relevant converter data. The adapters are divided into two mechanical types: *CMB* and *DMB*.

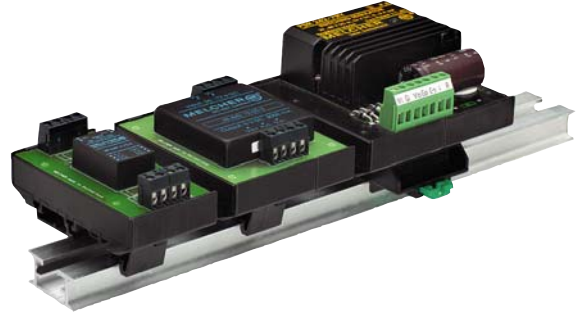

Table 2: Mounting Bracket survey

A1 [mm]	A2 [mm]	Converter case size	Converter series	Chassis-mounting Part no.	DIN-mounting Part no.	Delivery content
95.0	90.0	A01	PSR, PSA ($V_{i\max} = 40, 60, 80\text{ V}$)	CMBA01-iRY/80	DMBA01-iRY/80	PCB, screw terminal blocks, 4 diodes, capacitor C1 and C- or D-bracket with screws
			PSA ($V_{i\max} = 144\text{ V}$)	CMBA01-iRY/144	DMBA01-iRY/144	
72.5	67.5	2"×2"	IMR6, IMR15 IMP6, IMP12	CMB2×2-BCFG	DMB2×2-BCFG	PCB, screw terminal blocks, and C- or D-bracket
50.0	45.0	DIL 24	IMP1, IMP3, IXP3 IMX4 Option K	CMB3W-123	DMB3W-123	
72.5	67.5	1"×2"	IMX7, IMS7 IML10	CMB IMS/X7	DMBIMS/X7	See Basic Kit C/DMB IMX/S7

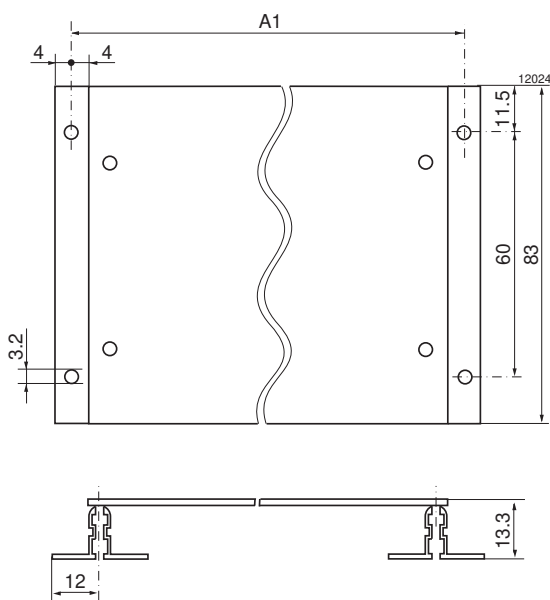

Fig. 4
CMB chassis mounting bracket dimensions
Bracket: Aluminium, black finish

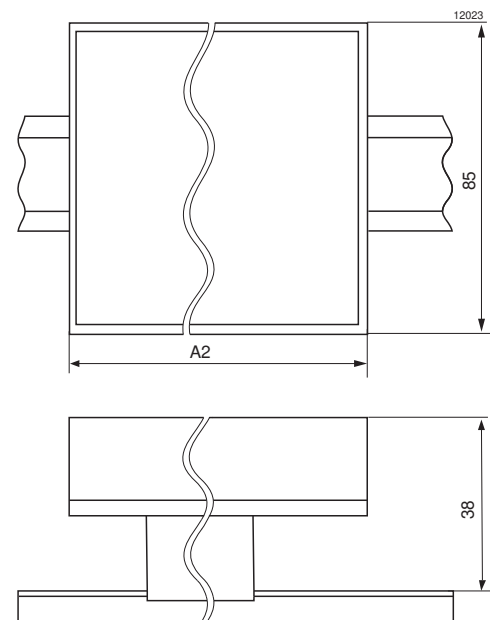

Fig. 5
DMB DIN-rail mounting bracket dimensions
Bracket: Polycarbonate, black

CMB: Chassis Mounting Bracket

The kit consists of a PCB for the converter, a set of screw terminals allowing for easy electrical connection and two aluminium profiles, attached to the PCB by means of four screws, which serve as the chassis mounting bracket. Four different versions according to table 2 are available.

Details on the layout of the PCBs and diagrams are given in the description below.

DMB: DIN-Rail Mounting Bracket

The DMB kit differs from the CMB version by a bracket suited for DIN-rail mounting (according to EN 50022). The black plastic body of the bracket holds the PCB by means of a snap-in device. Four different versions according to table 2 are available.

Details on the layout of the PCB's and diagrams are given in the description below.

C/DMBA01-.. Electrical Description

This bracket is designed for non-isolated Switching Regulators of the PSR and PSA series in the A01 case size, equipped with option Y. Technical details and further information, e.g., max. input voltage etc., are described in the PSR and PSA data sheets. The use of the optional inhibit-and-R-function (external output voltage adjustment with R1) is possible, and the device can be driven either from a DC-source or from a transformer secondary voltage.

- DC-input: Consider the forward voltage drop across the rectifier diodes (also providing reverse polarity protection). Capacitor C1 compensates the negative input impedance of the converter in case of long connection wires.
- AC-input: The recommended transformer secondary voltage is 48 VAC for PSR/PSA (with $V_{i\max} = 80\text{ V}$) and 72 VAC for PSA (with $V_{i\max} = 144\text{ V}$)

Exception: Input voltage for PSR54 (PSA55) is 20 VAC.

Note: PSR54 (PSA55) and PSR362 require an additional capacitor (C2) of at least 470 μF .

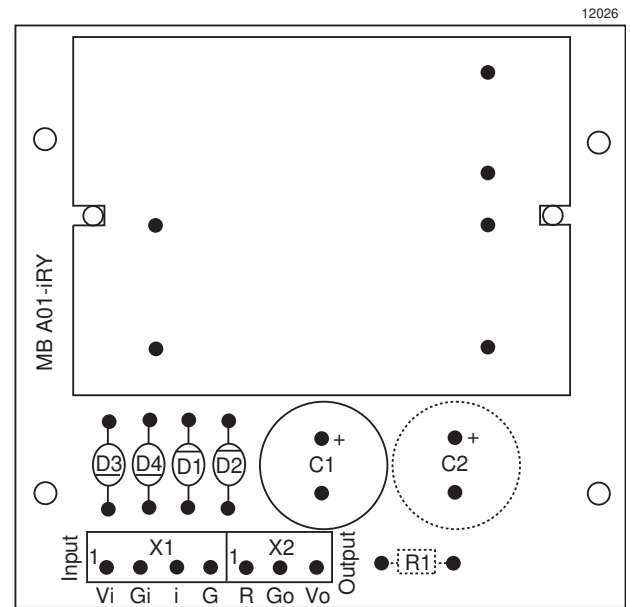
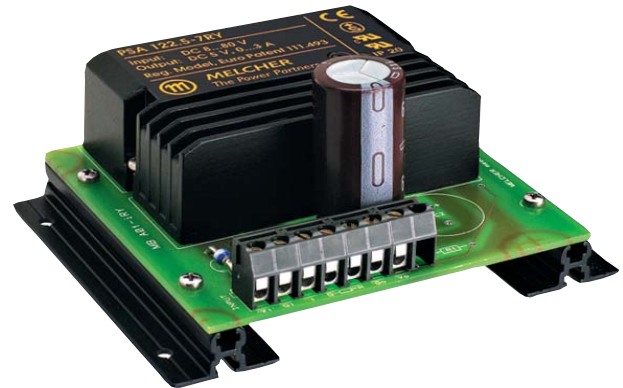

Fig. 6b
C/DMBA01- .. print layout

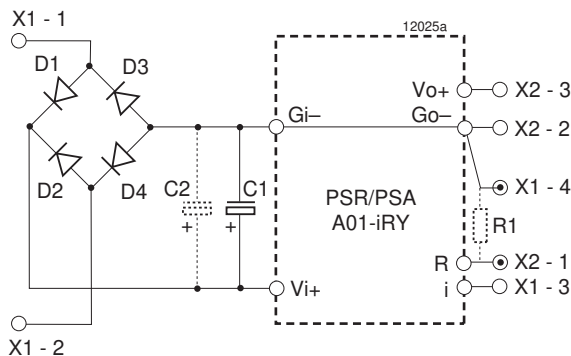

Fig. 6a
C/DMBA01- .. circuit diagram

C/DMB2x2-BCFG Electrical Description

This bracket allows the mounting of isolated DC-DC converters IMR6, IMR15, IMP6 and IMP12 in 2"x2" cases with either one or two output voltages of 5, 12 or 15 V. The technical details are given in the data sheets of IMR6, IMR15, IMP6, IMP12.

Depending on the application input transient protection may be incorporated (e.g. an appropriate Transzorb diode D1).

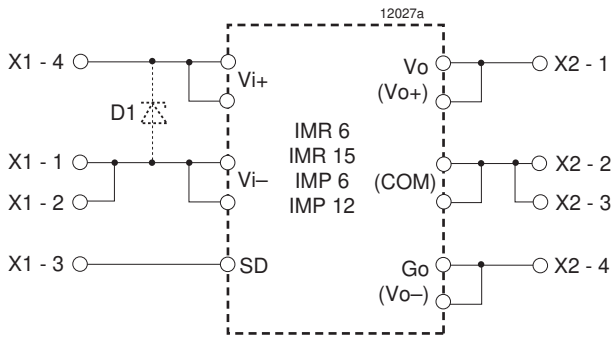

Fig. 7a
C/DMB2x2-BCFG circuit diagram

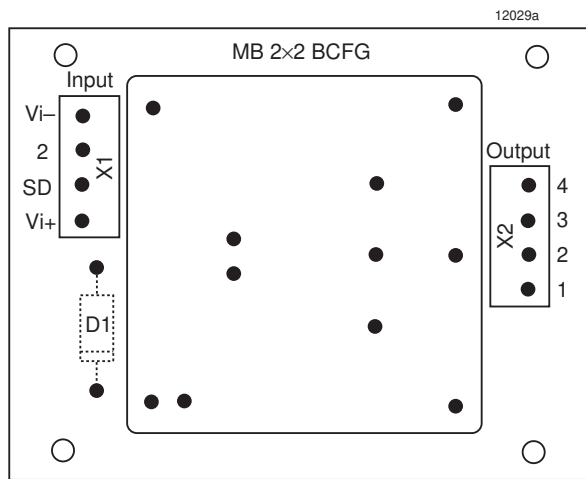

Fig. 7b
C/DMB2x2-BCFG print layout

C/DMB3W-123 Electrical Description

This bracket is designed for galvanically isolated DC-DC converters of the IMP1, IMP3 and IXP3, IMX4 and IMS6 (both with option K) series in DIL 24 cases with one or two output

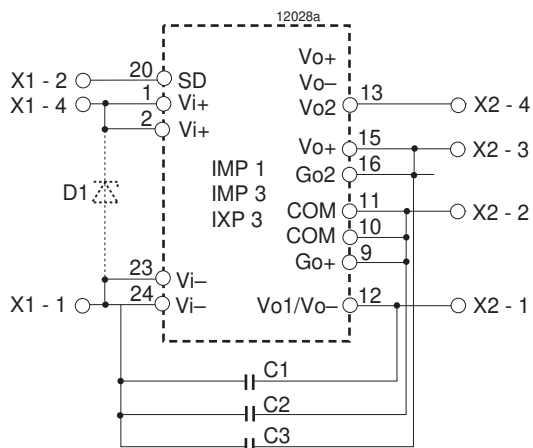

Fig. 8a
C/DMB3W-123 circuit diagram for all pin configurations

voltages. The pin configuration of the converter groups single, double, and dual, and all technical converter details are described in the data sheets.

Depending on the application input transient protection may be incorporated (e.g. an appropriate Transzorb diode D1) .

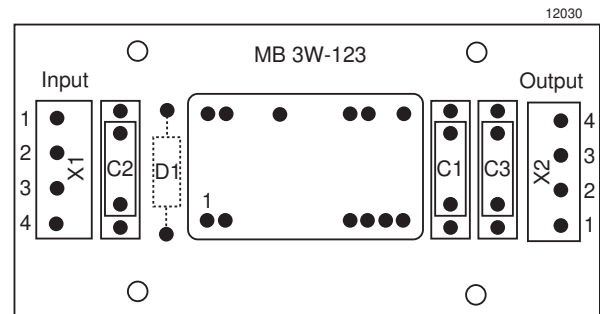

Fig. 8b
C/DMB3W-123 print layout

Basic Kit CMBIMX/S7

For use with 1"x2" DC-DC converter types:
IML10, IMS7 and IMX7

The basic kit contains the following:

- Two mounting rails, 83 mm
- Four screws M 2.5x6
- Four nuts M 2.5
- PCB ZGN 09601 A
- Three 2-pole terminal blocks (2x for X1 terminal, 1x for X3 terminal)
- One 3-pole terminal block for X2 terminal
- Three wire jumpers 5.08 mm (positions B1, B4, B5)
- One wire jumper 10.16 mm (position D1)
- Six wire jumpers 6.8 mm (positions L2, L4, L6)
- Circuit diagram no. YSK25300 S3 01

Basic Kit DMBIMX/S7

For use with 1"x2" DC-DC converter types:
IML10, IMS7 and IMX7

The basic kit contains the following:

- DIN-mounting support for 35 mm DIN-rail systems
- PCB ZGN 09601 A
- Three 2-pole terminal blocks (2x for X1 terminal, 1x for X3 terminal)
- One 3-pole terminal block for X2 terminal
- Three wire jumpers 5.08 mm (positions B1, B4, B5)
- One wire jumper 10.16 mm (position D1)
- Six wire jumpers 6.8 mm (positions L2, L4, L6)
- Circuit diagram no. YSK 25300 S3 01

Mounting Instructions for Basic Kit

Single output units IML10, IMS7, and IMX7:

- Solder the wire jumpers into positions as below:
 1. D1 (10.16 mm)
 2. B1 (5.08 mm), inhibit.
- Note:** This jumper should be fitted, if the inhibit is not actively used. An open inhibit disables the converter.
- 3. L2-A and L2-B, L6-A and L6-B (6.8 mm)
- 4. L4-A and L4-B (6.8 mm), only necessary, if the R-input is used.
- Solder terminal blocks
 5. X1: Position Vi+/ Vi–, 2-pole terminal block
 6. X1: Position i/n.c., 2-pole terminal block (only necessary in the case of remote inhibit)
 7. X3: Position Vo+/ Vo–, 2-pole terminal block
 8. X2: Position n.c., R, Vo–, 3-pole terminal block only necessary in the case of V_o adjustment by e.g. an external voltage source)
- Solder the selected DC-DC converter
- Mount PCB onto rails by using the 4 screws and nuts or snap PCB onto the DIN mounting support.
- Perform function test

Double output units IML10, IMS7, and IMX7:

- Solder the wire jumpers into positions as below:
 1. D1 (10.16 mm)
 2. B1 (5.08 mm), inhibit
- Note:** This jumper should be fitted, if the inhibit is not actively used. An open inhibit disables the converter.
- 3. L2-A and L2-B, L6-A and L6-B, L4-A and L4-B (all 6.8 mm)
- For applications with both outputs in parallel:
 4. Place/solder jumpers B4 and B5, (5.08 mm)
- Solder terminal blocks
 5. X1: Position Vi+/ Vi–, 2-pole terminal block
 6. X1: Position i/R (Trim), 2-pole terminal block (only necessary in the case of remote inhibit or output voltage trimming by an external voltage source)
 7. X3: Position Vo1+/ Vo1–, 2-pole terminal block
 8. X2: Position n.c./Vo2+/Vo2–, 3-pole terminal block
- Solder the selected DC-DC converter
- Mount PCB onto rails by using the 4 screws and nuts or snap PCB onto the DIN mounting support.
- Perform function test

Application-Specific Circuitry

The assembly C/DMB IMX/S7 offers a variety of additional external circuitries which may be implemented onto the PCB ZGN09601 A. See circuit diagram YSK 25300 S3 01. Please also consult the IMS/X7 data sheet.

Depending upon the application the following peripheral additions can be made:

- Reverse polarity protection by a series diode D1.
- Improved input transient protection according to IEC/EN 61000-4-5, level 2, by chokes L1 or L2-A, L2-B (EMC version) and capacitor C1.
- Remote inhibit.

Note: If the inhibit is not actively used the inhibit has to be connected to Vi– by jumper B1.
- External output voltage trimming/adjustment

Single output units:

- a) V_o – adjustment in the range of 70/75 – 100% of $V_{o\text{ nom}}$ by resistors RX3 or RX4 or combinations of RX3/RX4.
- b) V_o – adjustment in the range of 100 – 105% of $V_{o\text{ nom}}$ by resistors RX1 or RX2 or combinations of RX1/RX2.

Double output units:

- a) V_o – trimming by resistor R2 in the range of 100 - 105% of $V_{o\text{ nom}}$
- b) V_o – trimming in the range of 70/75 - 100% of $V_{o\text{ nom}}$ by a current diode together with a Zener diode D2 applicable for 24/48 IMS 7 and 20/40 IMX 7 types.

- Reduced output ripple (by approx. factor 5) by using chokes L3/L5 together with electrolytic capacitors C8/C9.
- Improved electromagnetic emission EN 55022, class B, lead length to load 1 m (class A for 110IMX7 types).

This requires all capacitors and output chokes as per circuit diagram YSK 25300 S3 /01 whereby the coupling capacitor C10 connected to Vi– via jumper B2 is foreseen for 24/48IMS/L types and 20/40/70IMX7 types.

For 110IMX7 types the coupling capacitor C11 or C12 should be used connected to Vo+ via jumper B3.

Notes:

- For single-output models or double-output models with both outputs in parallel, one filter set (L5 or L6-A/L6-B) together with C7 and C9 is sufficient.
- Wire jumpers B2 and B3 should not be mounted together onto the PCB as this would cause a short circuit.
- The coupling capacitors C10 or C11/12 should be Y2 ceramic types to maintain the outputs SELV.
- Application specific assemblies are available on request.

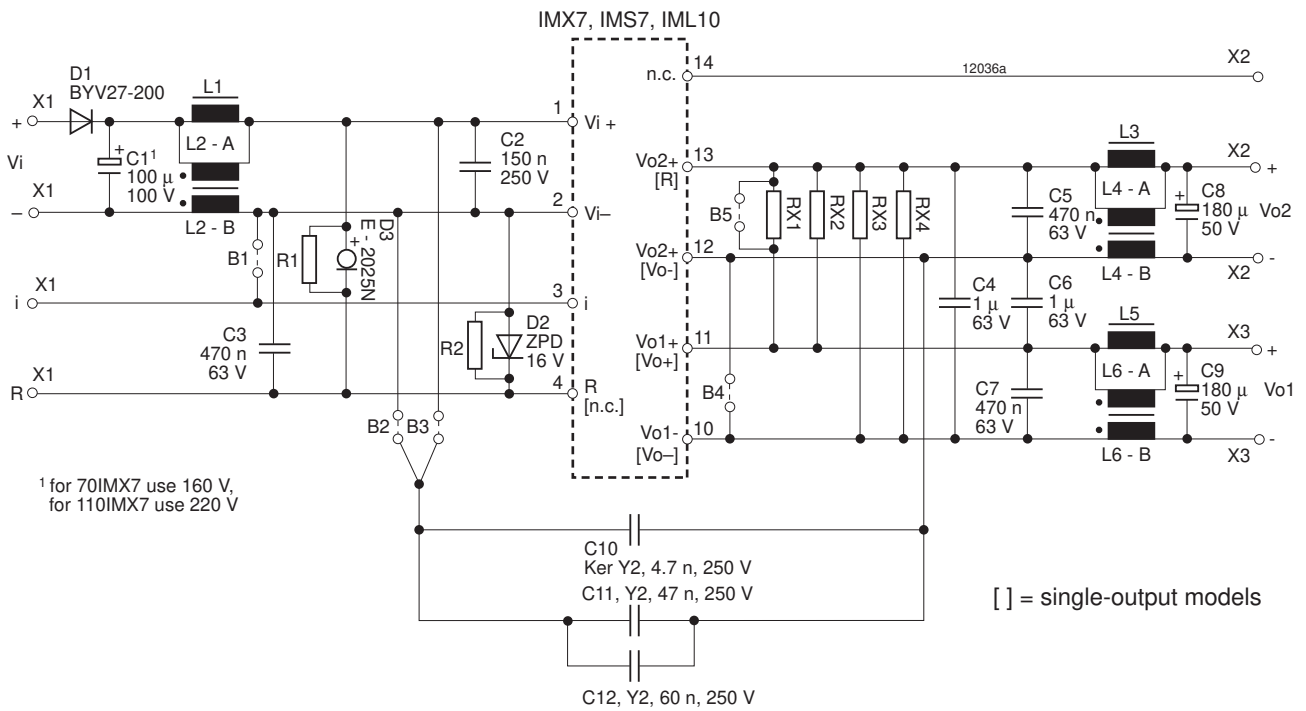

Fig. 9a
C/DMB circuit diagram with IMX7, IMS7, and IML10

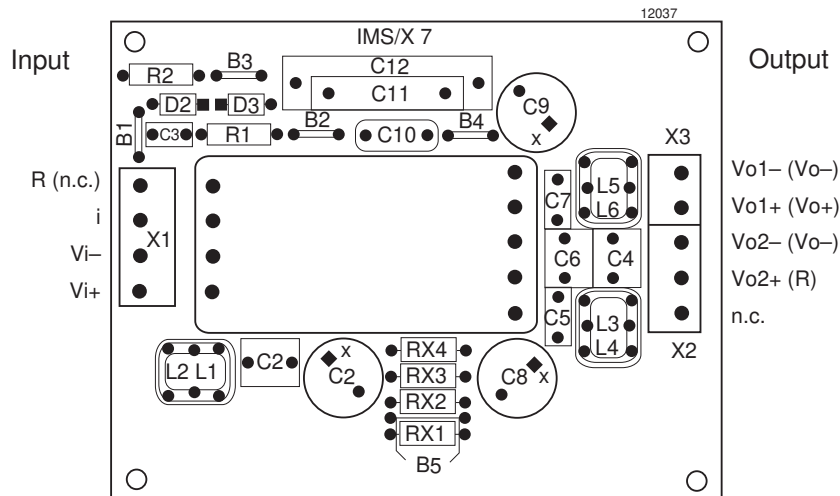

Fig. 9b
C/DMB arrangement of the terminals on the PCB for
IMX7, IMS7, and IML10

Note: Where the pin/terminal designations for single-output models deviate from double-output models, they are shown in brackets.

Universal Mounting Bracket
(DIN- and Chassis Mounting)

UMB-LHMQ

A special Universal Mounting Bracket has been designed for vertical or upright chassis- and DIN-rail mounting of the 19" cassette style converters shown in table 3.

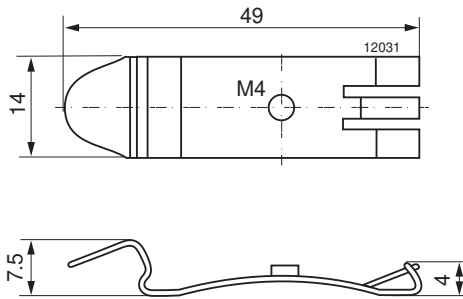

Fig. 10
DIN-rail clamp
Steel, galvanized

Table 3: Mounting bracket survey

Converter case size	Converter series	Bracket Item no.	Delivery content
L04 H02, M02 Q01, Q03, Q04	PSL H, M Q, LPC, P	UMB-LHMQ	Alu-profile, two screws and a DIN-rail clamp with screw

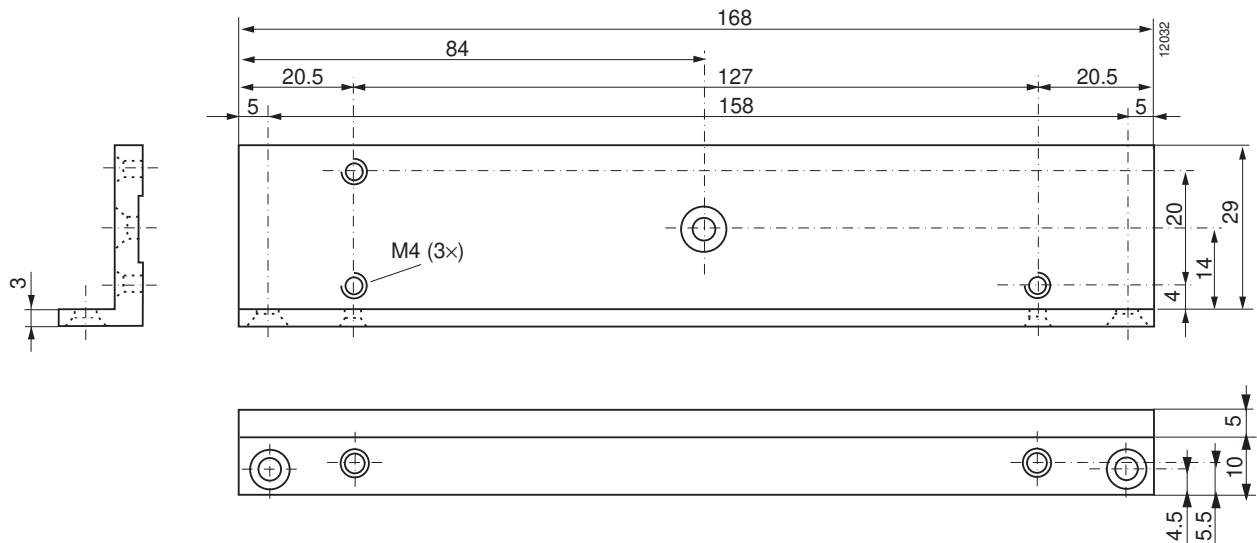

Fig. 11
VMB universal mounting bracket
Aluminium, untreated

DMB-K/S, DMB-MHQ

By means of these DMB mounting kits, the S, K, PSS, PSK (DMB-K/S) and the M, H, Q, LPC, P (DMB-MHQ) converters can be adapted to the DIN-rail. The kit consists of two aluminium brackets to be mounted on each side of the converter, including a clamp. The DMB-K/S kit contains two different sets of screws for the adaption of the brackets either to S/PSS or K/PSK converter types. The design of the kit is made such that the fixture is very tight, and as a result the assembly can also be used for mobile applications.

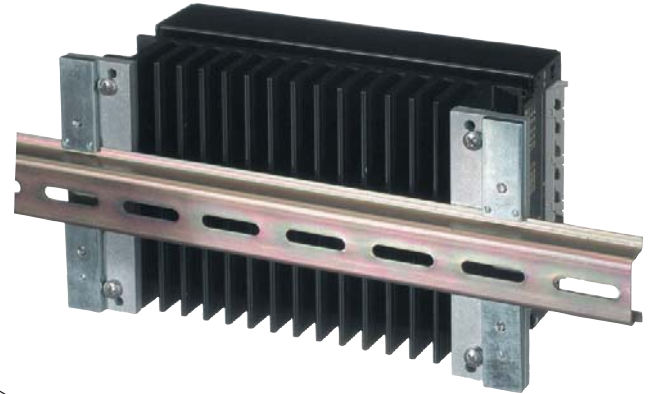

Table 4: Mounting bracket survey

Case size	Converter series	Type item no.
S01	PSS	DMB-K/S
S02	S	
K01	PSK	
K02	K	
M02	M	DMB-MHQ
H02	H	
Q01	Q ¹	
Q03	LPC ¹	
Q04	P ¹	

¹ Not together with screw-style connectors STV-H15-FSR(-G) [HZZ00107]

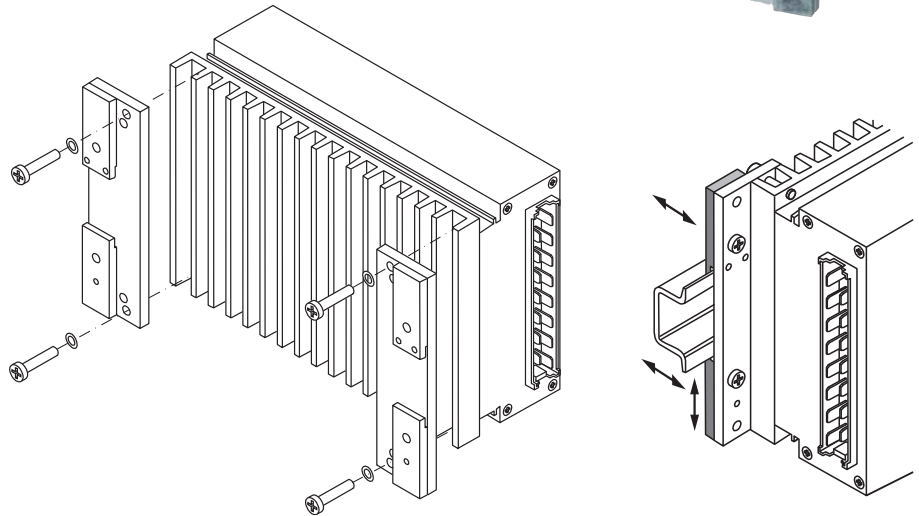

Fig. 12
Schematic view: Assembly of DMB-K/S

CMB-S

This mounting kit allows for chassis mounting of the S and PSS Series converters, if access is only possible from the front of the chassis.

Note: If space conditions are very tight, option B1 or B can be used instead of the heat sink. Refer to the data sheets of the respective converters.

This kit uses parts of the DMB-K/S kit since it consists of the same two brackets but without the clamps and fitted the other way round on the heat sink.

Table 5: Mounting bracket survey

Case size	Converter series	Type Part no.
S01	PSS	CMB-S
S02	S	



Isolation Pads for PCB Mounting

In applications, where PCB mounting converters are placed on top of double sided boards, the use of Isolation Pads is recommended. These fibre pads avoid short circuits and provide excellent protection against possible damage to tracks. For selection and item numbers refer to table below.

Table 6 : Isolation Pad survey

Case size	Converter series	Isolation pad	Dimensions [mm]	Item no.
A01	PSR, PSA	Isolation A	70 × 50 × 0.3	ISOLATIONA,A01
B02	PSB	Isolation B	107 × 71 × 0.3	ISLOATIONB,B02
C03	PSC	Isolation C	152 × 86 × 0.3	ISOLATIONC,C03
2"×2"	IMR 6/15	Isolation 2"×2"	53 × 53 × 0.3	ISOLATION2"×2"

PCB-Tags for PCB Mounting

Switching Regulators in B02 or C03 cases may also be mounted directly onto PCBs. The connection between the converters' fast-on pins and the PCB can be easily made by means of PCB-Tags.

Delivery content: 10 pieces
Part number: LOETGABEL(10x)

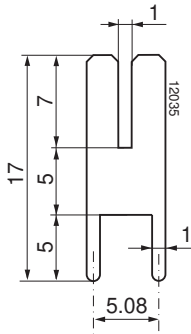

Fig. 13
PCB-Tag

NUCLEAR AND MEDICAL APPLICATIONS - Power-One products are not designed, intended for use in, or authorized for use as critical components in life support systems, equipment used in hazardous environments, or nuclear control systems without the express written consent of the respective divisional president of Power-One, Inc.

TECHNICAL REVISIONS - The appearance of products, including safety agency certifications pictured on labels, may change depending on the date manufactured. Specifications are subject to change without notice.