



Chipsmall Limited consists of a professional team with an average of over 10 year of expertise in the distribution of electronic components. Based in Hongkong, we have already established firm and mutual-benefit business relationships with customers from,Europe,America and south Asia,supplying obsolete and hard-to-find components to meet their specific needs.

With the principle of “Quality Parts,Customers Priority,Honest Operation,and Considerate Service”,our business mainly focus on the distribution of electronic components. Line cards we deal with include Microchip,ALPS,ROHM,Xilinx,Pulse,ON,Everlight and Freescale. Main products comprise IC,Modules,Potentiometer,IC Socket,Relay,Connector.Our parts cover such applications as commercial,industrial, and automotives areas.

We are looking forward to setting up business relationship with you and hope to provide you with the best service and solution. Let us make a better world for our industry!



Contact us

Tel: +86-755-8981 8866 Fax: +86-755-8427 6832

Email & Skype: info@chipsmall.com Web: www.chipsmall.com

Address: A1208, Overseas Decoration Building, #122 Zhenhua RD., Futian, Shenzhen, China



I16-COB00 User's Manual

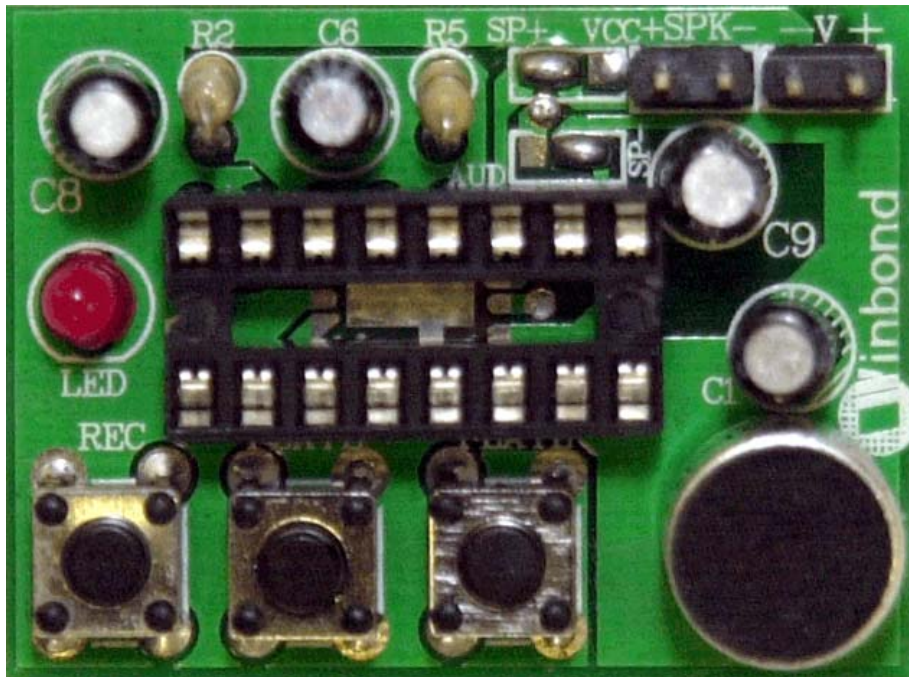

DESCRIPTION:

The I16-COB00 is used to demonstrate the voice quality of the ISD1600B ChipCorder series. This board has an empty PDIP socket, so that the desired device can be installed. It can also serve as a prototype board for your initial applications.

Product supported	Ordering Code
ISD1610B/12B/16B/20B	I16-COB00

CONTENTS OF THE KIT:

- I16-COB00 COB/Demo board
- User's manual

HARDWARE CONNECTIONS:

- Connect a speaker and a power supply to the related terminals. Please ensure the polarity of the power is correct to avoid any damages to the COB and/or the device.
- Speaker (SP)/AUD selection: Default setting is SP output. If AUD output is needed, remove the connection from center pad to Sp+ (Sp-) pad and re-connect the center pad to AUD (Vcc), respectively, per diagram below.

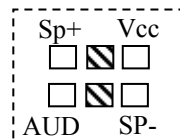

OPERATIONS:

In order to perform the recording and playback functions, just connect a speaker and a power supply to the demo board. Please ensure the polarity of the power is correct for avoiding any damages to the demo board.

To Record, simply press-and-hold the **REC** button and speak to the microphone. The LED stays on while recording. Release Record button to stop recording.

To Playback the recorded message using **PlayE**, simply pressing PlayE button once will play the message and it stops automatically when completed. During playback, pressing PlayE button again will halt the playback operation.

To Playback the recorded message using **PlayL**, simply pressing-and-holding PlayL button will play the message and it stops automatically when completed. During playback, releasing PlayL button will cease the playback operation.

To demonstrate the voice quality and various durations, one can change the Rosc to the desired value with respect to the sampling frequency, as shown in the datasheet.

SCHEMATIC:

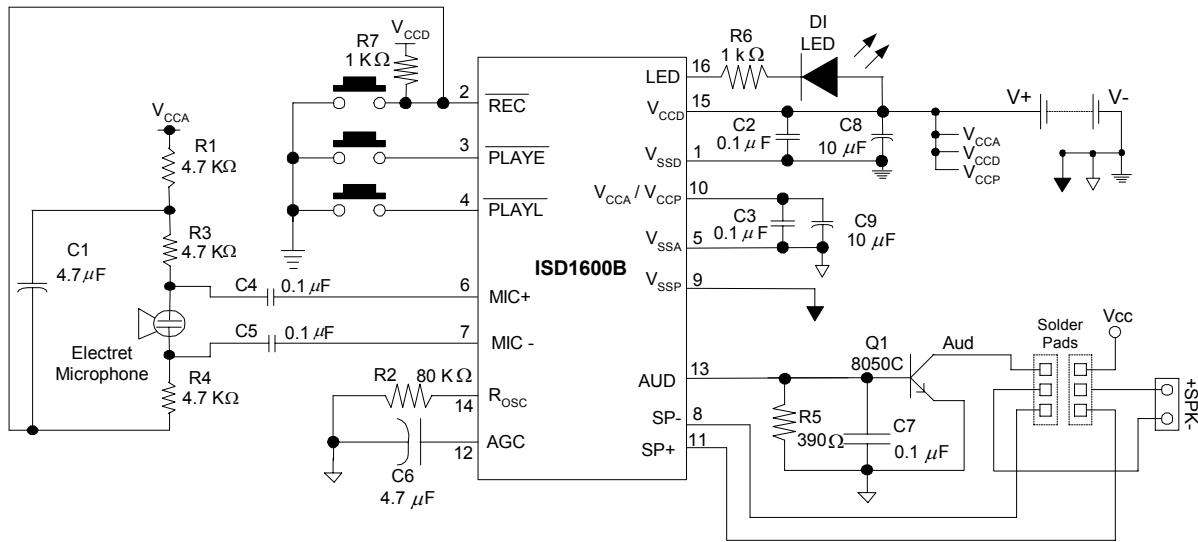

For any technical details of the ISD1600B series, please refer to the datasheet at:
<http://www.winbond-usa.com>

PCB LAYOUT PICTURES:

Dimension of PCB: 37.5 mm x 27.7 mm

