



Chipsmall Limited consists of a professional team with an average of over 10 year of expertise in the distribution of electronic components. Based in Hongkong, we have already established firm and mutual-benefit business relationships with customers from,Europe,America and south Asia,supplying obsolete and hard-to-find components to meet their specific needs.

With the principle of "Quality Parts,Customers Priority,Honest Operation,and Considerate Service",our business mainly focus on the distribution of electronic components. Line cards we deal with include Microchip,ALPS,ROHM,Xilinx,Pulse,ON,Everlight and Freescale. Main products comprise IC,Modules,Potentiometer,IC Socket,Relay,Connector.Our parts cover such applications as commercial,industrial, and automotives areas.

We are looking forward to setting up business relationship with you and hope to provide you with the best service and solution. Let us make a better world for our industry!



Contact us

Tel: +86-755-8981 8866 Fax: +86-755-8427 6832

Email & Skype: info@chipsmall.com Web: www.chipsmall.com

Address: A1208, Overseas Decoration Building, #122 Zhenhua RD., Futian, Shenzhen, China



DATA SHEET

74F657

Octal transceiver with 8-bit parity
generator/checker

Product data
Supersedes data of 1990 Jul 30

2003 Feb 04

Octal transceiver with 8-bit parity generator/checker

74F657

FEATURES

- Combines 74F245 and 74F280A functions in one package
- High impedance base input for reduced loading (70 μ A in HIGH and LOW states)
- Ideal in applications where high output drive and light bus loading are required (I_{OL} is 70 μ A versus FAST std of 600 μ A)
- 3-state buffer outputs sink 64 mA and source 15 mA
- Input diodes for termination effects
- 24-pin plastic slim DIP (300 mil) package
- Industrial temperature range available (−40 °C to +85 °C)

DESCRIPTION

The 74F657 is an octal transceiver featuring non-inverting buffers with 3-state outputs and an 8-bit parity generator/checker, and is intended for bus-oriented applications. The buffers have a guaranteed current sinking capability of 24 mA at the A ports and 64 mA at the B ports. The transmit/receive (T/R) input determines the direction of the data flow through the bidirectional transceivers.

Transmit (active HIGH) enables data from A ports to B ports; receive (active LOW) enables data from B ports to A ports.

The output enable (\overline{OE}) input disables both the A and B ports by placing them in a high impedance condition when the \overline{OE} input is HIGH.

The parity select (ODD/EVEN) input gives the user the option of odd or even parity systems.

The parity (PARITY) pin is an output from the generator/checker when transmitting from the port A to B (T/\overline{R} = HIGH) and an input when receiving from port B to A port (T/\overline{R} = LOW).

When transmitting (T/\overline{R} = HIGH) the parity select (ODD/EVEN) input is set, then the A port data is polled to determine the number of high bits. The parity (PARITY) output then goes to the logic state determined by the parity select (ODD/EVEN) setting and by the number of high bits on port A.

For example, if the parity select (ODD/EVEN) is set LOW (even parity), and the number of high bits on port A is odd, then the parity (PARITY) output will be HIGH, transmitting even parity. If the number of high bits on port A is even, then the parity (PARITY) output will be LOW, keeping even parity.

When in receive mode (T/\overline{R} = LOW) the B port is polled to determine the number of high bits. If parity select (ODD/EVEN) is LOW (even parity) and the number of highs on port B is:

(1) odd and the parity (PARITY) input is HIGH, then \overline{ERROR} will be HIGH, significantly no error.

(2) even and the parity (PARITY) input is HIGH, then \overline{ERROR} will be asserted LOW, indicating an error.

TYPE	TYPICAL PROPAGATION DELAY	TYPICAL SUPPLY CURRENT (TOTAL)
74F657	8.0ns	100 mA

ORDERING INFORMATION

DESCRIPTION	ORDER CODE		PKG DWG #
	COMMERCIAL RANGE $V_{CC} = 5V \pm 10\%$, $T_{amb} = 0\text{ }^{\circ}\text{C to } +70\text{ }^{\circ}\text{C}$	INDUSTRIAL RANGE $V_{CC} = 5V \pm 10\%$, $T_{amb} = -40\text{ }^{\circ}\text{C to } +85\text{ }^{\circ}\text{C}$	
24-pin plastic slim DIP (300 mil)	N74F657N	I74F657N	SOT222-1
24-pin plastic SOL	N74F657D	I74F657D	SOT137-1

INPUT AND OUTPUT LOADING AND FAN-OUT TABLE

PINS	DESCRIPTION	74F (U.L.) HIGH / LOW	LOAD VALUE HIGH / LOW
A0–A7	A ports 3–state inputs	3.5 / 0.117	70 μ A / 70 μ A
B0–B7	B ports 3–state inputs	3.5 / 0.117	70 μ A / 70 μ A
PARITY	Parity input	3.5 / 0.117	70 μ A / 70 μ A
T/R	Transmit/receive input	2.0 / 0.066	40 μ A / 40 μ A
ODD/EVEN	Parity select input	1.0 / 0.033	20 μ A / 20 μ A
\overline{OE}	Output enable input (active LOW)	2.0 / 0.066	40 μ A / 40 μ A
A0–A7	A ports 3–state outputs	150 / 40	3.0 mA / 24 mA
B0–B7	B ports 3–state outputs	750 / 106.7	15 mA / 64 mA
PARITY	Parity output	750 / 106.7	15 mA / 64 mA
ERROR	Error output	750 / 106.7	15 mA / 64 mA

NOTE:

1. One (1.0) FAST unit load is defined as: 20 μ A in the HIGH state and 0.6 mA in the LOW state.

Octal transceiver with 8-bit parity generator/checker

74F657

PIN CONFIGURATION

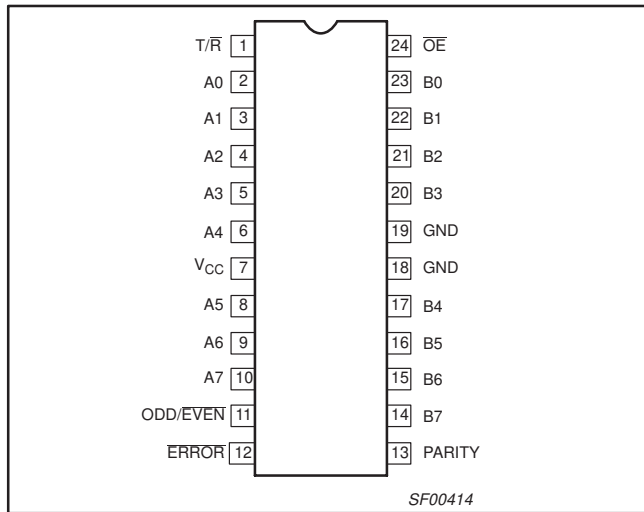

LOGIC SYMBOL

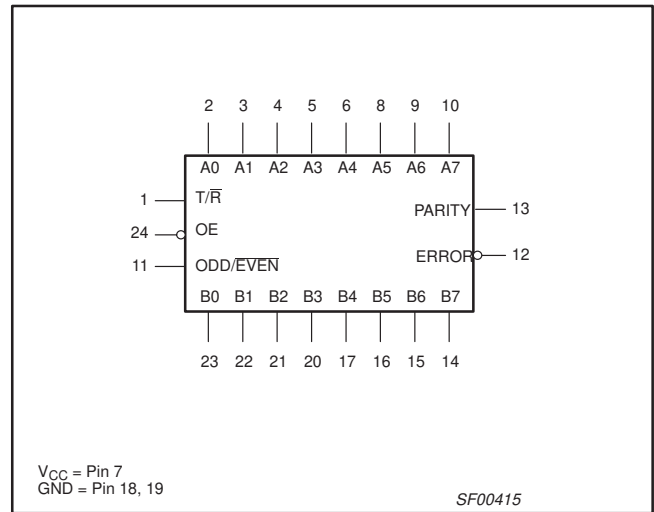

IEC/IEEE SYMBOL

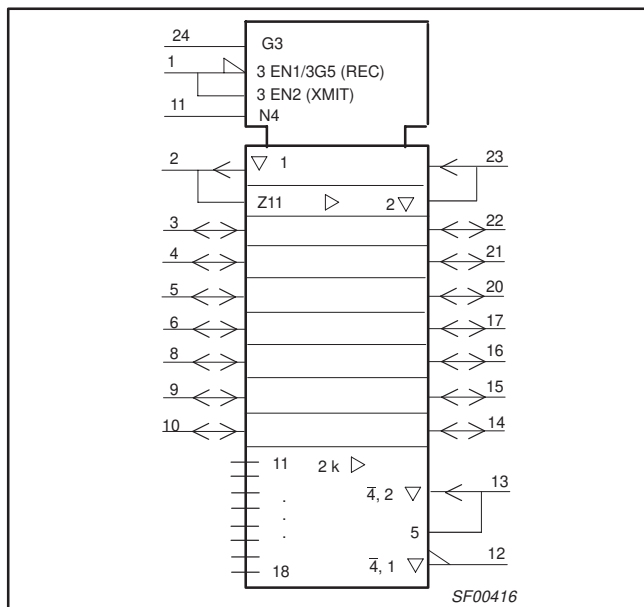

Octal transceiver with 8-bit parity generator/checker

74F657

LOGIC DIAGRAM

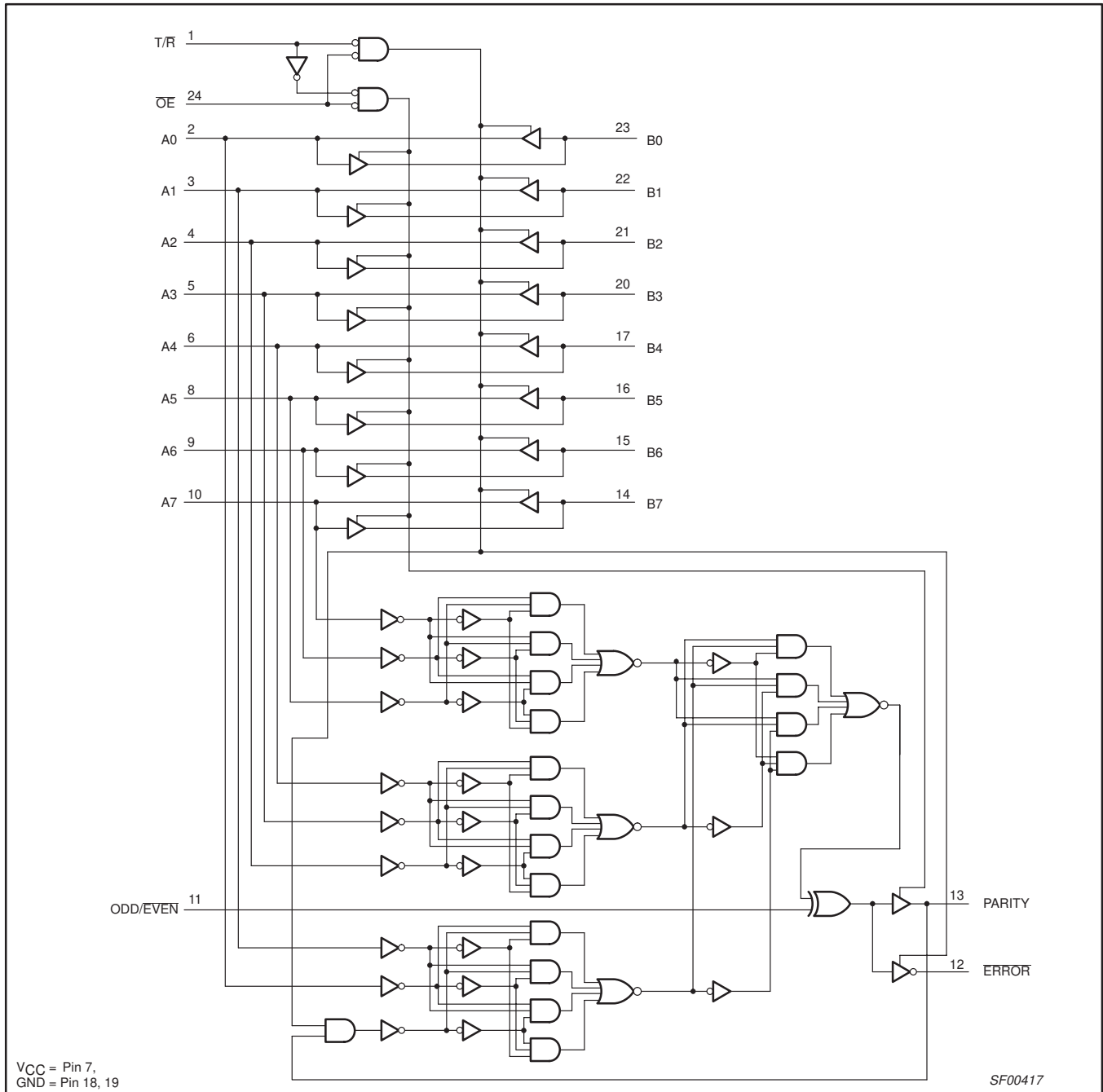

Octal transceiver with 8-bit parity generator/checker

74F657

FUNCTION TABLE

NUMBER OF INPUTS THAT ARE HIGH	INPUTS			INPUT/OUTPUT	OUTPUTS	
	OE	T/R	ODD/EVEN	PARITY	ERROR	OUTPUTS MODE
0, 2, 4, 6, 8	L	H	H	H	Z	Transmit
	L	H	L	L	Z	Transmit
	L	L	H	H	H	Receive
	L	L	H	L	L	Receive
	L	L	L	H	L	Receive
1, 3, 5, 7	L	H	H	L	Z	Transmit
	L	H	L	H	Z	Transmit
	L	L	H	H	L	Receive
	L	L	H	L	H	Receive
	L	L	L	H	H	Receive
Don't care	H	X	X	Z	Z	Z

Notes to function table

1. H = High voltage level
2. L = Low voltage level
3. X = Don't care
4. Z = High impedance "off" state

ABSOLUTE MAXIMUM RATINGS

Operation beyond the limit set forth in this table may impair the useful life of the device.

Unless otherwise noted these limits are over the operating free air temperature range.

SYMBOL	PARAMETER	RATING	UNIT
V _{CC}	Supply voltage	-0.5 to +7.0	V
V _{IN}	Input voltage	-0.5 to +7.0	V
I _{IN}	Input current	-30 to +5	mA
V _{OUT}	Voltage applied to output in HIGH output state	-0.5 to V _{CC}	V
I _{OUT}	Current applied to output in LOW output state	A0–A7	48
		B0–B7, PARITY, ERROR	128
T _{amb}	Operating free air temperature range	Commercial range	0 to +70
		Industrial range	-40 to +85
T _{stg}	Storage temperature range	-65 to +150	°C

RECOMMENDED OPERATING CONDITIONS

SYMBOL	PARAMETER	LIMITS			UNIT
		MIN	NOM	MAX	
V _{CC}	Supply voltage	4.5	5.0	5.5	V
V _{IH}	HIGH-level input voltage	2.0			V
V _{IL}	LOW-level input voltage			0.8	V
I _{Ik}	Input clamp current			-18	mA
I _{OH}	HIGH-level output current	A0–A7		-3	mA
		B0–B7, PARITY, ERROR		-15	mA
I _{OL}	LOW-level output current	A0–A7		24	mA
		B0–B7, PARITY, ERROR		64	mA
T _{amb}	Operating free air temperature range	Commercial range	0	+70	°C
		Industrial range	-40	+85	°C

Octal transceiver with 8-bit parity generator/checker

74F657

DC ELECTRICAL CHARACTERISTICS

Over recommended operating free-air temperature range unless otherwise noted.

SYMBOL	PARAMETER		TEST CONDITIONS ¹			LIMITS			UNIT	
						MIN	TYP ²	MAX		
V _{OH}	HIGH-level output voltage	All outputs	V _{CC} = MIN, V _{IL} = MAX, V _{IH} = MIN	I _{OH} = -3 mA ^{4,5}	±10%V _{CC}	2.4			V	
					±5%V _{CC}	2.7			V	
		B0-B7, PARITY, ERROR		I _{OH} = -12 mA ⁵	±10%V _{CC}	2.0			V	
					±5%V _{CC}	2.0			V	
				I _{OH} = -15 mA ⁴	±10%V _{CC}	2.0			V	
					±5%V _{CC}	2.0			V	
V _{OL}	LOW-level output voltage	A0-A7	V _{CC} = MIN, V _{IL} = MAX, V _{IH} = MIN	I _{OL} = 24 mA ^{4,5}	±10%V _{CC}		0.35	0.50	V	
					±5%V _{CC}		0.35	0.50	V	
		B0-B7, PARITY, ERROR		I _{OL} = 48 mA ⁴	±10%V _{CC}		0.38	0.55	V	
					±5%V _{CC}		0.42	0.55	V	
				I _{OL} = 48 mA ⁵	±10%V _{CC}		0.42	0.55	V	
					±5%V _{CC}		0.42	0.55	V	
V _{IK}	Input clamp voltage	V _{CC} = MIN, I _I = I _{IK}				-0.73	-1.2	V		
I _I	Input current at maximum input voltage	OE, T/R, ODD/EVEN	V _{CC} = 0.0 V, V _I = 7.0 V					100	μA	
		A0-A7	V _{CC} = 5.5 V, V _I = 5.5 V					2	mA	
		B0-B7						1	mA	
I _{IH}	HIGH-level input current	ODD/EVEN	V _{CC} = MAX, V _I = 2.7 V					20 ⁴	μA	
		OE, T/R						40 ⁵	μA	
								40 ⁴	μA	
I _{IL}	LOW-level input current	OOD/EVEN	V _{CC} = MAX, V _I = 0.5 V					-20	μA	
		OE, T/R						-40	μA	
I _{OZH} + I _{IH}	Off-state output current, HIGH-level voltage applied	A0-A7, B0-B7, PARITY	V _{CC} = MAX, V _O = 2.7 V					70	μA	
I _{OZL} + I _{IL}	Off-state output current, LOW-level voltage applied		V _{CC} = MAX, V _O = 0.5 V					-70	μA	
I _{OZH}	Off-state output current, HIGH-level voltage applied	ERROR	V _{CC} = MAX, V _O = 2.7 V					50	μA	
I _{OZL}	Off-state output current, LOW-level voltage applied		V _{CC} = MAX, V _O = 0.5 V					-50	μA	
I _{OS}	Short circuit output current ³	A0-A7	V _{CC} = MAX			-60		-150	mA	
		B0-B7				-100		-225	mA	
I _{CC}	Supply current (total)	I _{CCH}	V _{CC} = MAX				90	125 ⁴	mA	
								90	135 ⁵	mA
		I _{CCL}						106	150 ⁴	mA
								106	160 ⁵	mA
		I _{CCZ}				98	145	mA		

NOTES:

- For conditions shown as MIN or MAX, use the appropriate value specified under recommended operating conditions for the applicable type.
- All typical values are at V_{CC} = 5 V, T_{amb} = 25 °C.
- Not more than one output should be shorted at a time. For testing I_{OS}, the use of high-speed test apparatus and/or sample-and-hold techniques are preferable in order to minimize internal heating and more accurately reflect operational values. Otherwise, prolonged shorting of a high output may raise the chip temperature well above normal and thereby cause invalid readings in other parameter tests. In any sequence of parameter tests, I_{OS} tests should be performed last.
- For commercial range.
- For industrial range.

Octal transceiver with 8-bit parity generator/checker

74F657

AC ELECTRICAL CHARACTERISTICS

SYMBOL	PARAMETER	TEST CONDITION	LIMITS								UNIT
			T _{amb} = +25 °C V _{CC} = +5.0 V C _L = 50 pF, R _L = 500 Ω			T _{amb} = 0 °C to +70 °C V _{CC} = +5.0 V ± 10% C _L = 50 pF, R _L = 500 Ω		T _{amb} = -40 °C to +85 °C V _{CC} = +5.0 V ± 10% C _L = 50 pF, R _L = 500 Ω			
			MIN	TYP	MAX	MIN	MAX	MIN	MAX		
t _{PLH} t _{PHL}	Propagation delay An to Bn or Bn to An	Waveform 2	2.5 3.0	5.5 6.0	7.5 7.5	2.5 3.0	8.0 8.0	2.0 2.5	9.0 9.0	ns	
t _{PLH} t _{PHL}	Propagation delay An to PARITY	Waveform 1, 2	7.0 7.0	10.0 10.0	14.0 15.0	7.0 7.0	16.0 16.0	5.5 6.5	16.5 19.0	ns	
t _{PLH} t _{PHL}	Propagation delay ODD/EVEN to PARITY, ERROR	Waveform 1, 2	4.5 4.5	7.5 8.0	11.0 11.5	4.5 4.5	12.0 12.5	3.5 4.0	13.0 15.5	ns	
t _{PLH} t _{PHL}	Propagation delay Bn to ERROR	Waveform 1, 2	8.0 8.0	14.0 14.0	20.5 20.5	7.5 7.5	22.5 22.5	7.5 7.5	24.5 25.0	ns	
t _{PLH} t _{PHL}	Propagation delay PARITY to ERROR	Waveform 1, 2	8.0 8.0	11.5 12.0	15.5 15.5	7.5 8.0	16.5 17.0	6.5 6.5	18.5 20.0	ns	
t _{PZH} t _{PZL}	Output enable time ¹ to HIGH or LOW level	Waveform 3, 4	3.0 4.0	5.5 7.0	8.0 9.5	3.0 4.0	9.0 11.0	2.0 4.0	9.0 13.0	ns	
t _{PHZ} t _{PLZ}	Output disable time from HIGH or LOW level	Waveform 3, 4	2.0 2.0	4.5 4.0	7.5 6.0	2.0 2.0	8.0 6.5	1.0 1.0	8.0 7.5	ns	

NOTE:

1. These delay times reflect the 3-state recovery time only and not the signal through the buffers or the parity check circuitry. To assure **VALID** information at the **ERROR** pin, time must be allowed for the signal to propagate through the drivers (B to A), through the parity check circuitry (same as A to PARITY), and to the **ERROR** output. **VALID** data at the **ERROR** pin ≥ (B to A) + (A to PARITY).

AC WAVEFORMS

For all waveforms, V_M = 1.5 V.

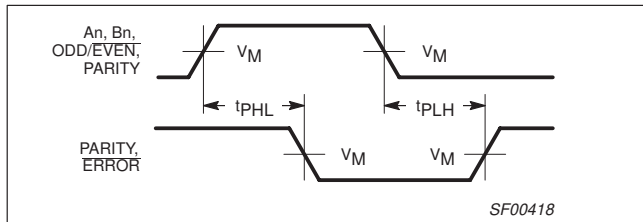

Waveform 1. Propagation delay for inverting outputs

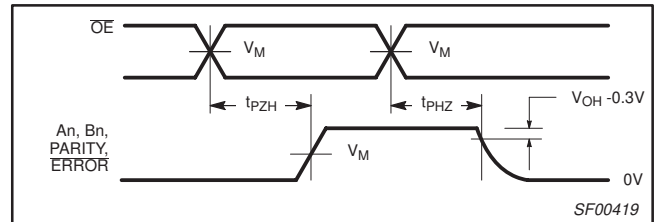

Waveform 3. 3-state output enable time to HIGH level and output disable time from HIGH level

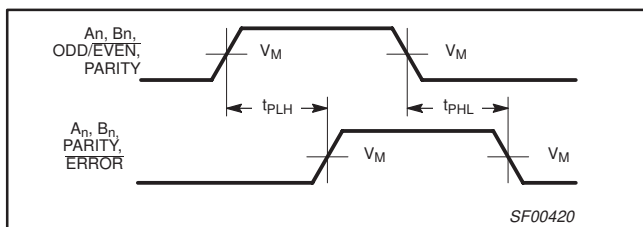

Waveform 2. Propagation delay for non-inverting outputs

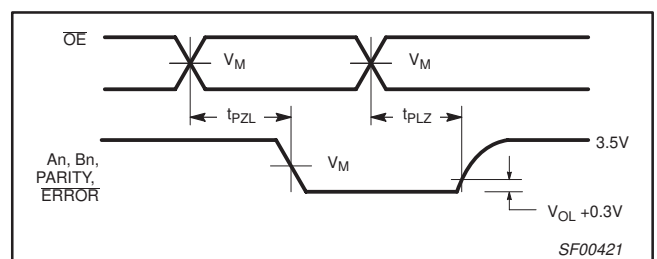

Waveform 4. 3-state output enable time to LOW level and output disable time from LOW level

Octal transceiver with 8-bit parity generator/checker

74F657

TEST CIRCUIT AND WAVEFORMS

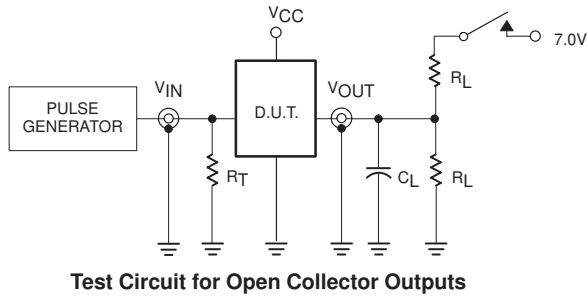

Test Circuit for Open Collector Outputs

SWITCH POSITION

TEST	SWITCH
t_{PLZ}	closed
t_{PZL}	closed
All other	open

DEFINITIONS:

- R_L = Load resistor; see AC electrical characteristics for value.
- C_L = Load capacitance includes jig and probe capacitance; see AC electrical characteristics for value.
- R_T = Termination resistance should be equal to Z_{OUT} of pulse generators.

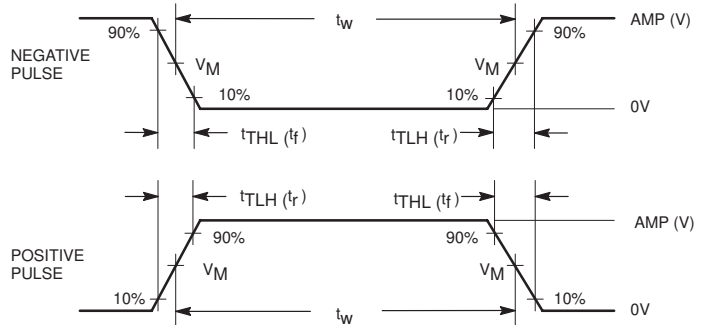

Input Pulse Definition

family	INPUT PULSE REQUIREMENTS					
	amplitude	V_M	rep. rate	t_w	t_{TLH}	t_{THL}
74F	3.0V	1.5V	1MHz	500ns	2.5ns	2.5ns

SF00128

Octal transceiver with 8-bit parity generator/checker

74F657

DIP24: plastic dual in-line package; 24 leads (300 mil)

SOT222-1

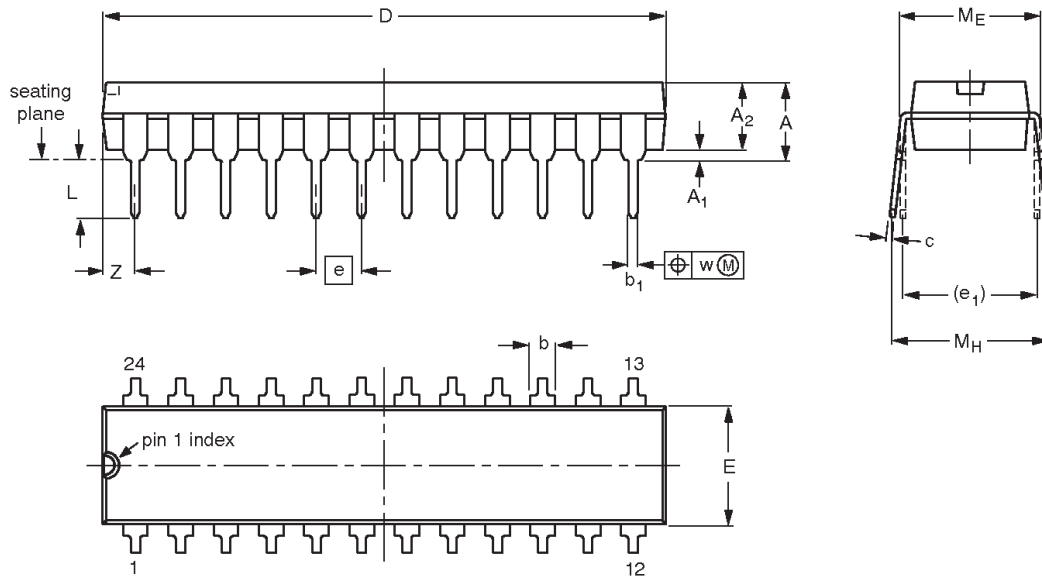

DIMENSIONS (millimetre dimensions are derived from the original inch dimensions)

UNIT	A max.	A ₁ min.	A ₂ max.	b	b ₁	c	D ⁽¹⁾	E ⁽¹⁾	e	e ₁	L	M _E	M _H	w	Z ⁽¹⁾ max.
mm	4.70	0.38	3.94	1.63 1.14	0.56 0.43	0.36 0.25	31.9 31.5	6.73 6.25	2.54	7.62	3.51 3.05	8.13 7.62	10.03 7.62	0.25	2.05
inches	0.185	0.015	0.155	0.064 0.045	0.022 0.017	0.014 0.010	1.256 1.240	0.265 0.246	0.100	0.300	0.138 0.120	0.32 0.30	0.395 0.300	0.01	0.081

Note

1. Plastic or metal protrusions of 0.01 inches maximum per side are not included.

OUTLINE VERSION	REFERENCES				EUROPEAN PROJECTION	ISSUE DATE
	IEC	JEDEC	EIAJ			
SOT222-1		MS-001				99-04-28 99-12-27

Octal transceiver with 8-bit parity generator/checker

74F657

SO24: plastic small outline package; 24 leads; body width 7.5 mm

SOT137-1

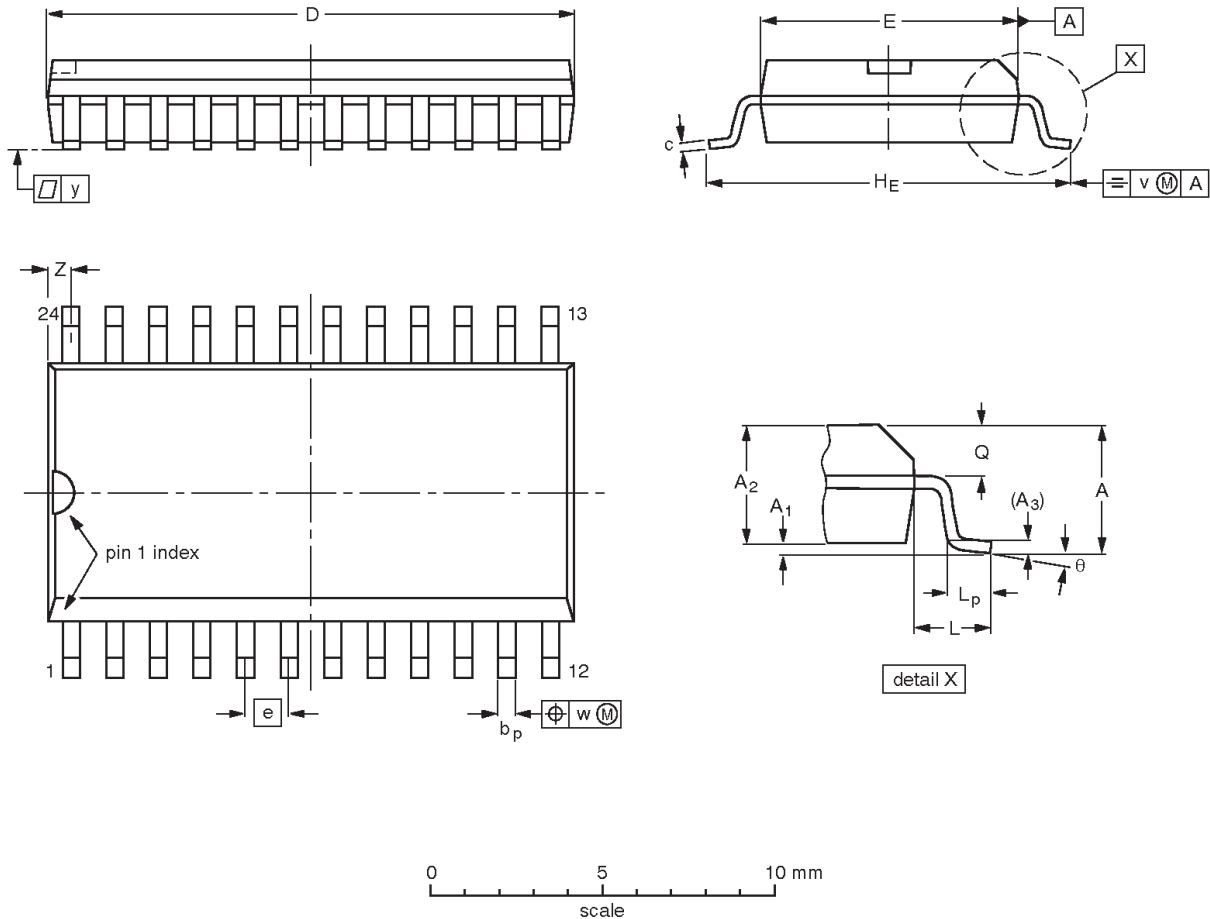

DIMENSIONS (inch dimensions are derived from the original mm dimensions)

UNIT	A max.	A ₁	A ₂	A ₃	b _p	c	D ⁽¹⁾	E ⁽¹⁾	e	H _E	L	L _p	Q	v	w	y	z ⁽¹⁾	θ
mm	2.65	0.30 0.10	2.45 2.25	0.25	0.49 0.36	0.32 0.23	15.6 15.2	7.6 7.4	1.27	10.65 10.00	1.4	1.1 0.4	1.1 1.0	0.25	0.25	0.1	0.9 0.4	8° 0°
inches	0.10	0.012 0.004	0.096 0.089	0.01	0.019 0.014	0.013 0.009	0.61 0.60	0.30 0.29	0.050	0.419 0.394	0.055	0.043 0.016	0.043 0.039	0.01	0.01	0.004	0.035 0.016	

Note

1. Plastic or metal protrusions of 0.15 mm maximum per side are not included.

OUTLINE VERSION	REFERENCES				EUROPEAN PROJECTION	ISSUE DATE
	IEC	JEDEC	EIAJ			
SOT137-1	075E05	MS-013				-97-05-22 99-12-27

Octal transceiver with 8-bit parity generator/checker

74F657

REVISION HISTORY

Rev	Date	Description
_3	20030204	Product data (9397 750 11038); ECN 853-1117 29307 of 17 December 2002. Supersedes Product specification of 1990 Jul 30. Modifications: <ul style="list-style-type: none">• Delete all references to DB (SSOP24) package; package option discontinued.
_2	19900730	Product specification (9397 750 05171); ECN 853-1117 00081 of 30 July 1990.

Octal transceiver with 8-bit parity generator/checker

74F657

Data sheet status

Level	Data sheet status ^[1]	Product status ^{[2] [3]}	Definitions
I	Objective data	Development	This data sheet contains data from the objective specification for product development. Philips Semiconductors reserves the right to change the specification in any manner without notice.
II	Preliminary data	Qualification	This data sheet contains data from the preliminary specification. Supplementary data will be published at a later date. Philips Semiconductors reserves the right to change the specification without notice, in order to improve the design and supply the best possible product.
III	Product data	Production	This data sheet contains data from the product specification. Philips Semiconductors reserves the right to make changes at any time in order to improve the design, manufacturing and supply. Relevant changes will be communicated via a Customer Product/Process Change Notification (CPCN).

[1] Please consult the most recently issued data sheet before initiating or completing a design.

[2] The product status of the device(s) described in this data sheet may have changed since this data sheet was published. The latest information is available on the Internet at URL <http://www.semiconductors.philips.com>.

[3] For data sheets describing multiple type numbers, the highest-level product status determines the data sheet status.

Definitions

Short-form specification — The data in a short-form specification is extracted from a full data sheet with the same type number and title. For detailed information see the relevant data sheet or data handbook.

Limiting values definition — Limiting values given are in accordance with the Absolute Maximum Rating System (IEC 60134). Stress above one or more of the limiting values may cause permanent damage to the device. These are stress ratings only and operation of the device at these or at any other conditions above those given in the Characteristics sections of the specification is not implied. Exposure to limiting values for extended periods may affect device reliability.

Application information — Applications that are described herein for any of these products are for illustrative purposes only. Philips Semiconductors make no representation or warranty that such applications will be suitable for the specified use without further testing or modification.

Disclaimers

Life support — These products are not designed for use in life support appliances, devices, or systems where malfunction of these products can reasonably be expected to result in personal injury. Philips Semiconductors customers using or selling these products for use in such applications do so at their own risk and agree to fully indemnify Philips Semiconductors for any damages resulting from such application.

Right to make changes — Philips Semiconductors reserves the right to make changes in the products—including circuits, standard cells, and/or software—described or contained herein in order to improve design and/or performance. When the product is in full production (status 'Production'), relevant changes will be communicated via a Customer Product/Process Change Notification (CPCN). Philips Semiconductors assumes no responsibility or liability for the use of any of these products, conveys no license or title under any patent, copyright, or mask work right to these products, and makes no representations or warranties that these products are free from patent, copyright, or mask work right infringement, unless otherwise specified.

Contact information

For additional information please visit
<http://www.semiconductors.philips.com>. Fax: +31 40 27 24825

© Koninklijke Philips Electronics N.V. 2003
 All rights reserved. Printed in U.S.A.

Date of release: 02-03

For sales offices addresses send e-mail to:
sales.addresses@www.semiconductors.philips.com.

Document order number: 9397 750 11038

Let's make things better.