



Chipsmall Limited consists of a professional team with an average of over 10 year of expertise in the distribution of electronic components. Based in Hongkong, we have already established firm and mutual-benefit business relationships with customers from,Europe,America and south Asia,supplying obsolete and hard-to-find components to meet their specific needs.

With the principle of "Quality Parts,Customers Priority,Honest Operation,and Considerate Service",our business mainly focus on the distribution of electronic components. Line cards we deal with include Microchip,ALPS,ROHM,Xilinx,Pulse,ON,Everlight and Freescale. Main products comprise IC,Modules,Potentiometer,IC Socket,Relay,Connector.Our parts cover such applications as commercial,industrial, and automotives areas.

We are looking forward to setting up business relationship with you and hope to provide you with the best service and solution. Let us make a better world for our industry!



Contact us

Tel: +86-755-8981 8866 Fax: +86-755-8427 6832

Email & Skype: info@chipsmall.com Web: www.chipsmall.com

Address: A1208, Overseas Decoration Building, #122 Zhenhua RD., Futian, Shenzhen, China



SIZE	DIMENSIONS						
	A±0.38	B±0.12	C±0.10	D ^{+0.25} ₋₀	E	F	G
14/15	30.81	24.99	16.96	16.21	7.68	8.19	2.285
26	39.14	33.32	25.18	24.54	7.02	8.01	2.285
44	53.03	47.04	39.12	38.25	7.01	8.02	2.285

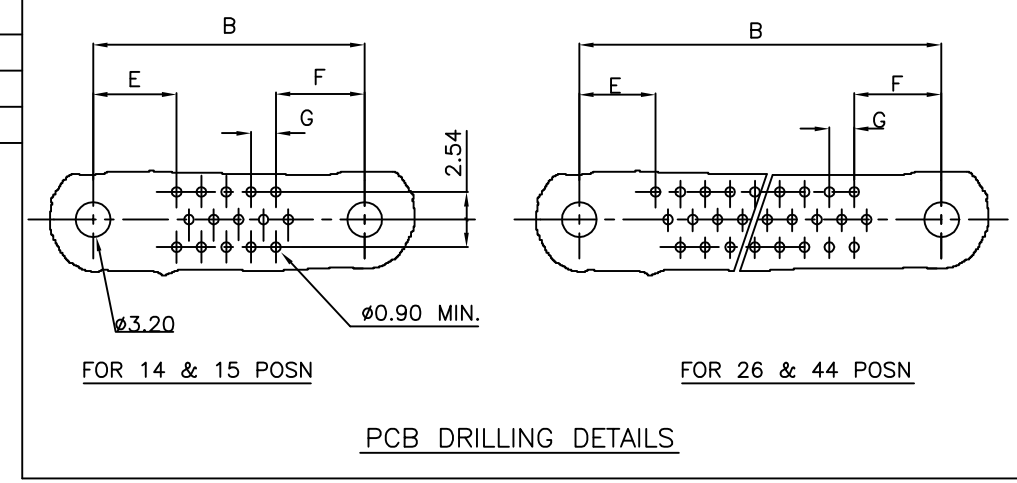
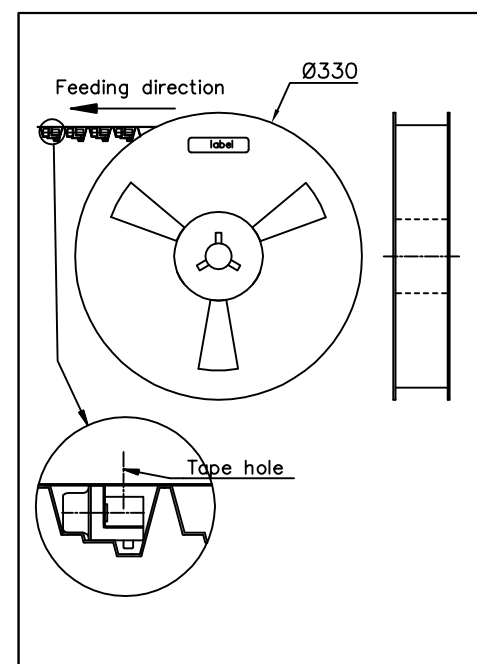
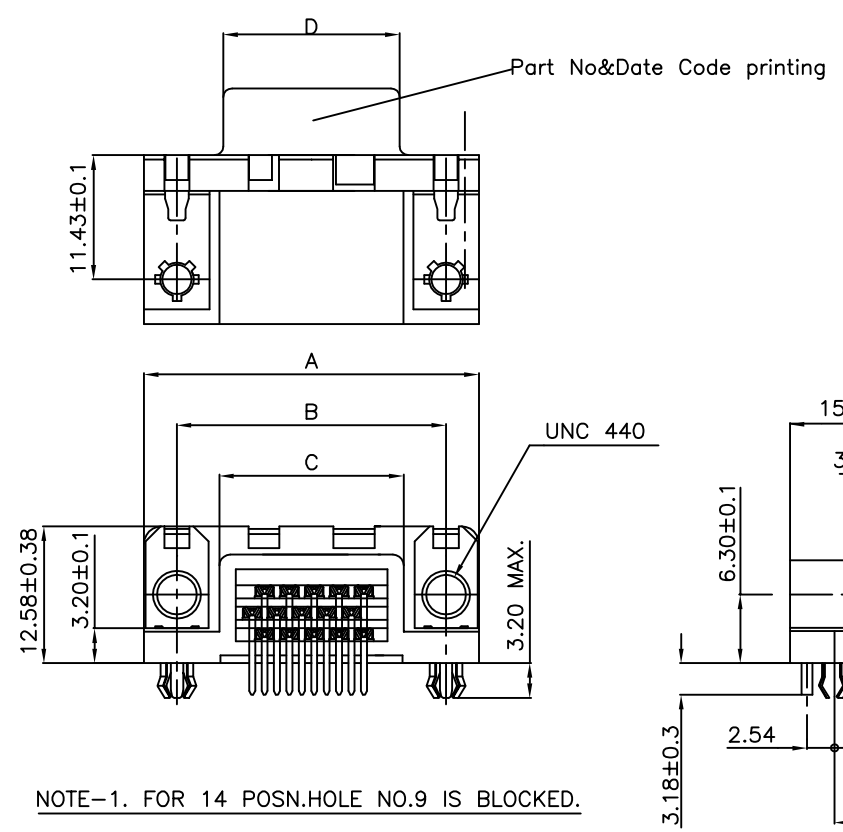

TECHNICAL SPECIFICATIONS

MATERIAL	
SHELL	: STEEL TIN/Zinc Cr 3 PLATED.
INSULATORS	: SELF EXTINGUISHING THERMOPLASTIC, UL CLASS94V0
CONTACTS	: COPPER ALLOY
PLATING	
ACTIVE ZONE	: GOLD OVER NICKEL
TERMINATION ZONE	: SnPb over Ni
FOR LEAD FREE TERMINATION	: 2 µ MIN.MATTE TIN TOP OVER 1.27 µ MIN.NICKEL UNDER PLATE
METAL BRACKET	: BRASS,TIN/Zinc Cr 3 PLATED.
SCREW LOCK	: BRASS,TIN/Zinc Cr 3 PLATED.
HARPOON	: BRASS,TIN PLATED.
CLINCH NUT	: BRASS,TIN/Zinc Cr 3 PLATED.
ELECTRICAL DATA	
MAX.CURRENT RATING	: 3A
TEST VOLTAGE	: 1000V
RATED VOLTAGE	: 300V
CONTACT RESISTANCE	: <25mΩ
SHELL RESISTANCE	: <5mΩ
INSULATION RESISTANCE	: >5000MΩ
ENVIRONMENTAL CHARACTERISTICS.	
OPERATING TEMPERATURE RANGE	: -55°C +125°C
MECHANICAL CHARACTERISTICS	
MATING/UNMATING CYCLES (Min.)	: 200 MATINGS FOR ≤0.40µ GOLD PLATING 500 MATINGS FOR >0.75µ GOLD PLATING
INSERTION/EXTRACTION FORCE PER CONTACTS: 5 N Max./0.3 N Min.	

ORDERING INFORMATION

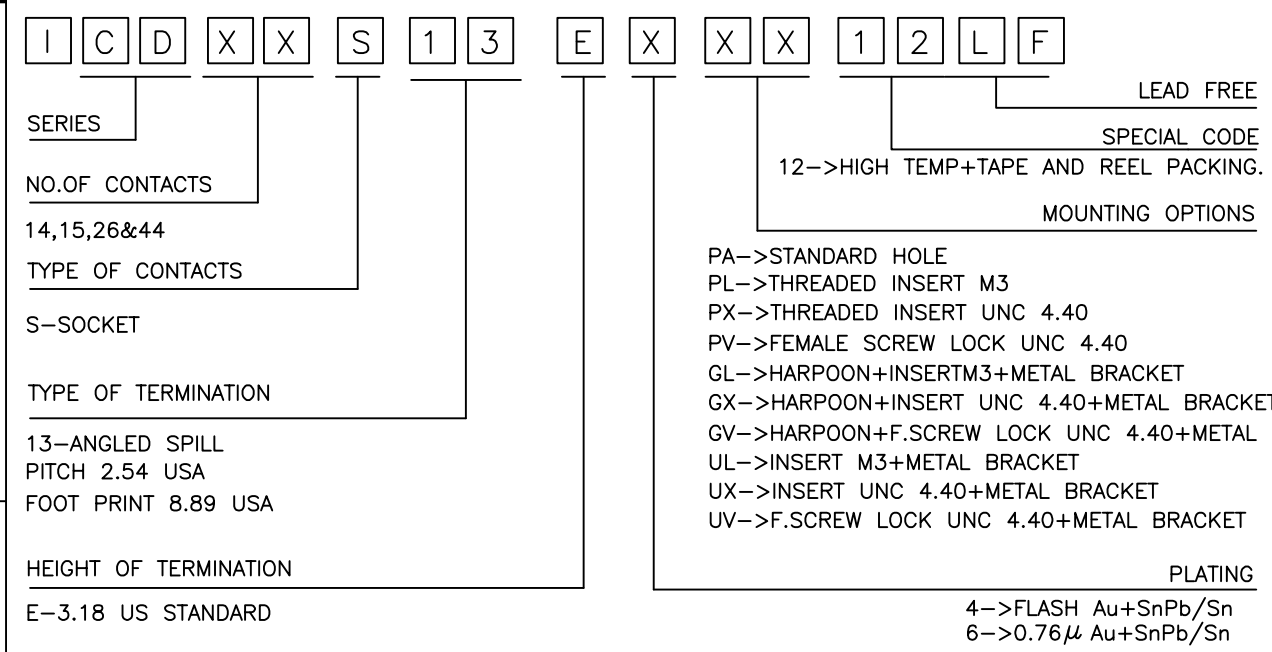

Packaging Details
Tape according to EIA-481-B
Anti static Property-
As per EIA-541
Reel ø 330mm
Qty - 75 nos/ reel
Empty Pockets
3 pockets min.and 300mm
extra cover tape at begining
and 5 pockets min. at the end.

"This LF product meets European Union Directives and other country regulations as described in GS-22-008"
The housing will withstand exposure to 260°C peak temperature for 30 seconds in a convection,infra-red or vapor reflow oven solder application.
Packaging as per GS-14-920

mat'l. code		surface	tolerance	projection	product family
		ISO 1302	ISO 406 ISO 1101		COMPACT D
litr ecn no dr date		tolerances unless otherwise specified		MM	title
D	I06-0074	GVJ	2006-06-08		
E	I09-0202	NG	2009-09-24	sheet 1 of 1	size 5
		angles	linear		
		0°±1°	.00±0.1	sheet 1 of 1	size 5
			.000±.00X		
		dr	GEORGE.V.JOSEPH	sheet 1 of 1	size 5
		engr	NIRMAL.GEORGE		
		chr	NIRMAL.GEORGE	sheet 1 of 1	size 5
		appd	SUDHIR.VARMA		
sheet index		revision sheet	D E	type Product Customer Drawing	
1 1					

FCI
FCconnect.com
Copyright FCI