



Chipsmall Limited consists of a professional team with an average of over 10 year of expertise in the distribution of electronic components. Based in Hongkong, we have already established firm and mutual-benefit business relationships with customers from,Europe,America and south Asia,supplying obsolete and hard-to-find components to meet their specific needs.

With the principle of "Quality Parts,Customers Priority,Honest Operation,and Considerate Service",our business mainly focus on the distribution of electronic components. Line cards we deal with include Microchip,ALPS,ROHM,Xilinx,Pulse,ON,Everlight and Freescale. Main products comprise IC,Modules,Potentiometer,IC Socket,Relay,Connector.Our parts cover such applications as commercial,industrial, and automotives areas.

We are looking forward to setting up business relationship with you and hope to provide you with the best service and solution. Let us make a better world for our industry!



## Contact us

Tel: +86-755-8981 8866 Fax: +86-755-8427 6832

Email & Skype: info@chipsmall.com Web: www.chipsmall.com

Address: A1208, Overseas Decoration Building, #122 Zhenhua RD., Futian, Shenzhen, China



# CoolSET<sup>®</sup>-F3R

## ICE3RBR1765JZ

Off-Line SMPS Current Mode  
Controller with integrated 650V  
CoolMOS<sup>®</sup> and Startup cell  
(frequency jitter Mode) in DIP-7

Power Management & Supply



Previous Version: 0.0

---

Page	Subjects (major changes since last revision)
3	add applications

For questions on technology, delivery and prices please contact the Infineon Technologies Offices in Germany or the Infineon Technologies Companies and Representatives worldwide: see our webpage at <http://www.infineon.com>

CoolMOS<sup>®</sup>, CoolSET<sup>®</sup> are trademarks of Infineon Technologies AG.

**Edition 2013-6-7****Published by****Infineon Technologies AG,****81726 Munich, Germany,****© 2013 Infineon Technologies AG.****All Rights Reserved.****Legal disclaimer**

The information given in this document shall in no event be regarded as a guarantee of conditions or characteristics. With respect to any examples or hints given herein, any typical values stated herein and/or any information regarding the application of the device, Infineon Technologies hereby disclaims any and all warranties and liabilities of any kind, including without limitation, warranties of non-infringement of intellectual property rights of any third party.

**Information**

For further information on technology, delivery terms and conditions and prices, please contact your nearest Infineon Technologies Office ([www.infineon.com](http://www.infineon.com)).

**Warnings**

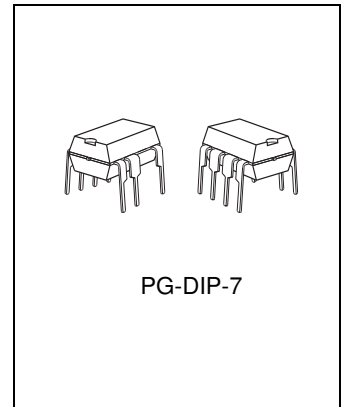
Due to technical requirements, components may contain dangerous substances. For information on the types in question, please contact your nearest Infineon Technologies Office.

Infineon Technologies Components may be used in life-support devices or systems only with the express written approval of Infineon Technologies, if a failure of such components can reasonably be expected to cause the failure of that life-support device or system or to affect the safety or effectiveness of that device or system. Life support devices or systems are intended to be implanted in the human body or to support and/or maintain and sustain and/or protect human life. If they fail, it is reasonable to assume that the health of the user or other persons may be endangered.

## Off-Line SMPS Current Mode Controller with integrated 650V CoolMOS® and Startup cell (frequency jitter Mode) in DIP-7

### Product Highlights

- Active Burst Mode to reach the lowest Standby Power Requirements < 50mW
- Auto Restart protection for overload, overtemperature, overvoltage
- External auto-restart enable function
- Built-in soft start and blanking window
- Extendable blanking Window for high load jumps
- Built-in frequency jitter and soft driving for low EMI
- Low Operating temperature down to -40°C
- Green Mould Compound
- Pb-free lead plating; RoHS compliant



### Features

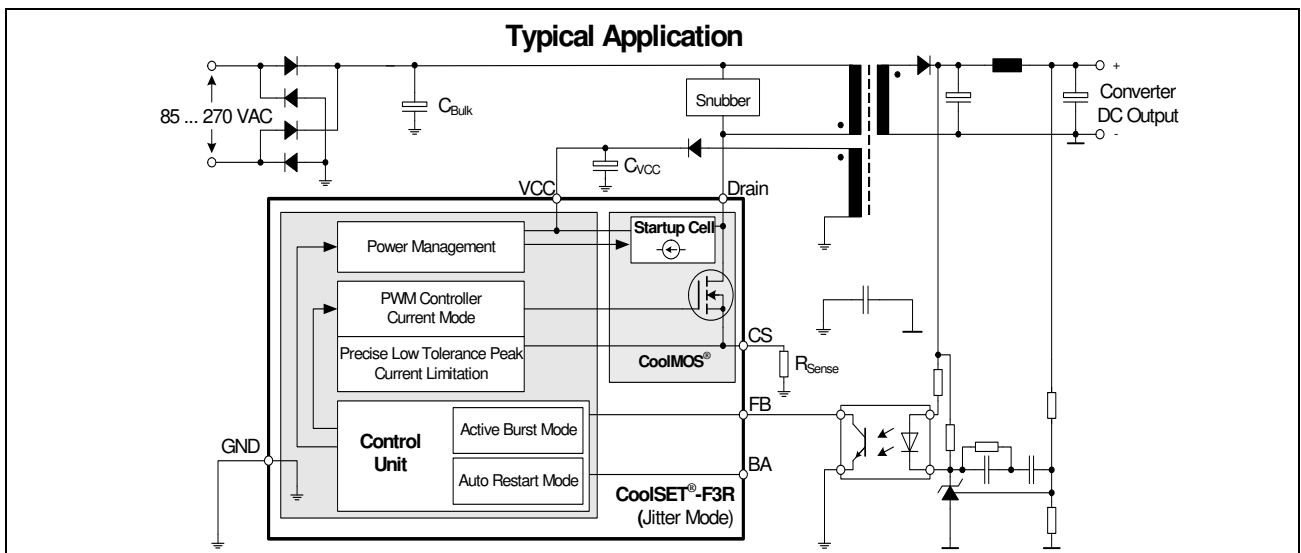
- 650V avalanche rugged CoolMOS® with built-in Startup Cell
- Active Burst Mode for lowest Standby Power
- Fast load jump response in Active Burst Mode
- 65kHz internally fixed switching frequency
- Auto Restart Protection Mode for Overload, Open Loop, VCC Undervoltage, Overtemperature & Overvoltage
- Built-in Soft Start
- Built-in blanking window with extendable blanking time for short duration high current
- External auto-restart enable pin
- Max Duty Cycle 75%
- Overall tolerance of Current Limiting < ±5%
- Internal PWM Leading Edge Blanking
- BiCMOS technology provide wide VCC range
- Built-in Frequency jitter and soft driving for low EMI

### Description

ICE3RBR1765JZ (ICE3RBRxx65JZ series) is modified from ICE3BRxx65JZ in DIP-7 package. It has more robust design and can work to -40°C. The outstanding performance includes BiCMOS technology, active burst mode, built-in frequency jitter, soft gate driving, propagation delay compensation, built-in soft start time, built-in blanking time and extendable blanking time for over load protection, external auto-restart enable feature, etc.

### Applications

- Adapter/Charger
- Blue Ray/DVD player, Set-top Box, Digital Photo Frame
- Auxiliary power supply for Server, PC, Printer, TV, Home theater/Audio System, White Goods, etc



Type	Package	Marking	V <sub>DS</sub>	F <sub>OSC</sub>	R <sub>DSon</sub> <sup>1)</sup>	230VAC ±15% <sup>2)</sup>	85-265 VAC <sup>2)</sup>
ICE3RBR1765JZ	PG-DIP-7	3RBR1765JZ	650V	65kHz	1.70	44.5W	29.5W

<sup>1)</sup> typ @ T<sub>j</sub>=25°C

<sup>2)</sup> Calculated maximum input power rating at T<sub>a</sub>=50°C, T<sub>i</sub>=125°C and without copper area as heat sink. Refer to input power curve for other T<sub>a</sub>.



<b>Table of Contents</b>		<b>Page</b>
<b>1</b>	<b>Pin Configuration and Functionality</b> .....	<b>6</b>
1.1	Pin Configuration with PG-DIP-7 .....	6
1.2	Pin Functionality .....	6
<b>2</b>	<b>Representative Blockdiagram</b> .....	<b>7</b>
<b>3</b>	<b>Functional Description</b> .....	<b>8</b>
3.1	Introduction .....	8
3.2	Power Management .....	8
3.3	Improved Current Mode .....	9
3.3.1	PWM-OP .....	10
3.3.2	PWM-Comparator .....	10
3.4	Startup Phase .....	11
3.5	PWM Section .....	12
3.5.1	Oscillator .....	12
3.5.2	PWM-Latch FF1 .....	12
3.5.3	Gate Driver .....	13
3.6	Current Limiting .....	13
3.6.1	Leading Edge Blanking .....	14
3.6.2	Propagation Delay Compensation .....	14
3.7	Control Unit .....	15
3.7.1	Basic and Extendable Blanking Mode .....	15
3.7.2	Active Burst Mode .....	15
3.7.2.1	Entering Active Burst Mode .....	15
3.7.2.2	Working in Active Burst Mode .....	16
3.7.2.3	Leaving Active Burst Mode .....	16
3.7.3	Protection Modes .....	17
3.7.3.1	Auto Restart mode with extended blanking time .....	17
3.7.3.2	Auto Restart without extended blanking time .....	18
<b>4</b>	<b>Electrical Characteristics</b> .....	<b>19</b>
4.1	Absolute Maximum Ratings .....	19
4.2	Operating Range .....	20
4.3	Characteristics .....	20
4.3.1	Supply Section .....	20
4.3.2	Internal Voltage Reference .....	21
4.3.3	PWM Section .....	21
4.3.4	Soft Start time .....	21
4.3.5	Control Unit .....	22
4.3.6	Current Limiting .....	23
4.3.7	CoolMOS <sup>®</sup> Section .....	23
<b>5</b>	<b>Typical CoolMOS<sup>®</sup> Performance Characteristic</b> .....	<b>24</b>

6	<b>Input Power Curve</b> .....	26
7	<b>Outline Dimension</b> .....	27
8	<b>Marking</b> .....	28
9	<b>Schematic for recommended PCB layout</b> .....	29

# 1 Pin Configuration and Functionality

## 1.1 Pin Configuration with PG-DIP-7

Pin	Symbol	Function
1	BA	extended Blanking & Auto-restart enable
2	FB	FeedBack
3	CS	Current Sense/ 650V <sup>1)</sup> CoolMOS <sup>®</sup> Source
4	n.c.	not connected
5	Drain	650V <sup>1)</sup> CoolMOS <sup>®</sup> Drain
6	n.c.	Not connected
7	VCC	Controller Supply Voltage
8	GND	Controller GrouND

<sup>1)</sup> at  $T_j=110^{\circ}\text{C}$

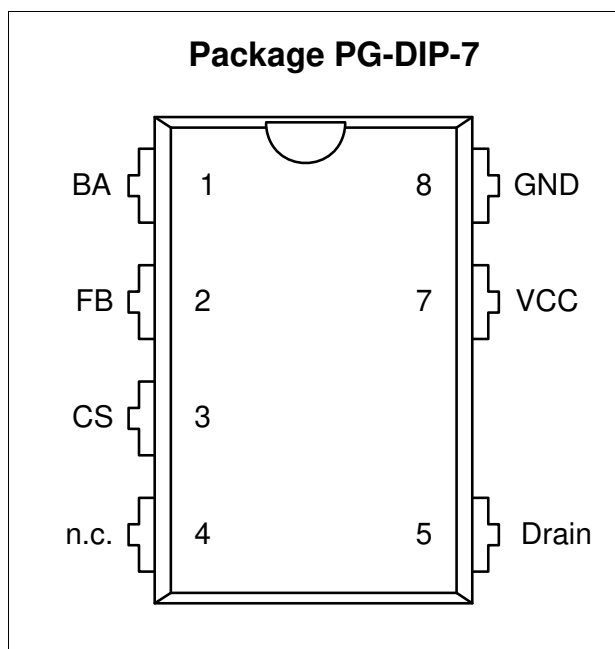


Figure 1 Pin Configuration PG-DIP-7 (top view)

## 1.2 Pin Functionality

### BA (extended Blanking & Auto-restart enable)

The BA pin combines the functions of extendable blanking time for over load protection and the external auto-restart enable. The extendable blanking time function is to extend the built-in 20 ms blanking time by adding an external capacitor at BA pin to ground. The external auto-restart enable function is an external access to stop the gate switching and force the IC enter auto-restart mode. It is triggered by pulling down the BA pin to less than 0.33V.

### FB (Feedback)

The information about the regulation is provided by the FB Pin to the internal Protection Unit and to the internal PWM-Comparator to control the duty cycle. The FB-Signal is the only control signal in case of light load at the Active Burst Mode.

### CS (Current Sense)

The Current Sense pin senses the voltage developed on the series resistor inserted in the source of the integrated CoolMOS<sup>®</sup>. If voltage in CS pin reaches the internal threshold of the Current Limit Comparator, the Driver output is immediately switched off. Furthermore the current information is provided for the PWM-Comparator to realize the Current Mode.

### Drain (Drain of integrated CoolMOS<sup>®</sup>)

Drain pin is the connection to the Drain of the integrated CoolMOS<sup>®</sup>.

### VCC (Power Supply)

VCC pin is the positive supply of the IC. The operating range is between 10.5V and 25V.

### GND (Ground)

GND pin is the ground of the controller.

Representative Blockdiagram

2 Representative Blockdiagram

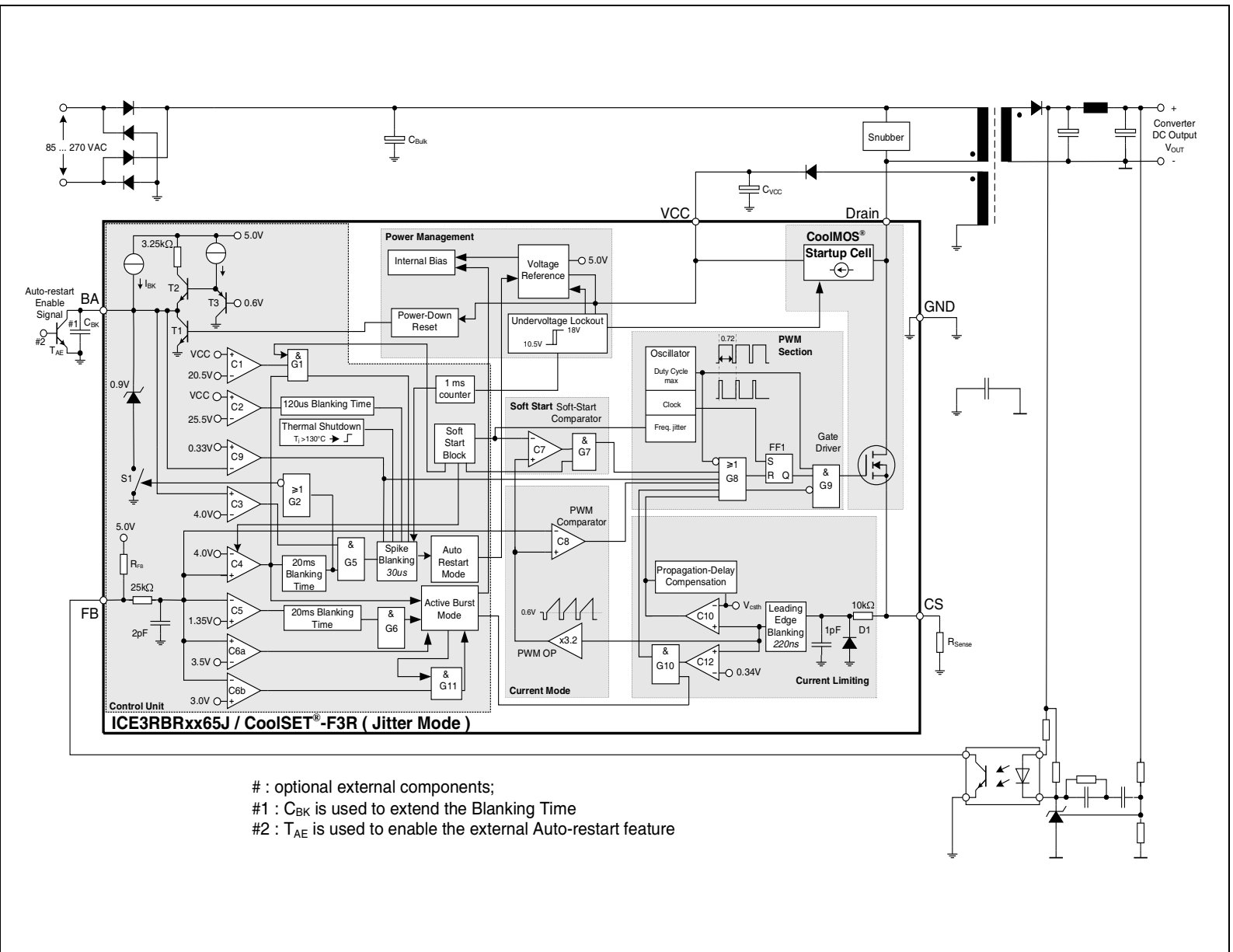


Figure 2 Representative Blockdiagram



### 3 Functional Description

All values which are used in the functional description are typical values. For calculating the worst cases the min/max values which can be found in section 4 Electrical Characteristics have to be considered.

#### 3.1 Introduction

ICE3RBR1765JZ (ICE3RBRxx65JZ series) is derived from ICE3BRxx65J in DIP-7 package. It has more robust design and can work to  $-40^{\circ}\text{C}$ .

A high voltage Startup Cell is integrated into the IC which is switched off once the Undervoltage Lockout on-threshold of 18V is exceeded. This Startup Cell is part of the integrated CoolMOS<sup>®</sup>. The external startup resistor is no longer necessary as this Startup Cell is connected to the Drain. Power losses are therefore reduced. This increases the efficiency under light load conditions drastically.

The particular features are the active burst mode, propagation delay compensation, modulated gate driving, auto-restart protection for  $V_{CC}$  overvoltage, over temperature, over load, open loop, built-in soft start, blanking window and frequency jitter. It provides the flexibility to increase the blanking window by simply addition of a capacitor in BA pin. In order to further increase the flexibility of the protection feature, an external auto-restart enable features are added.

The intelligent Active Burst Mode can effectively obtain the lowest Standby Power at light load and no load conditions. After entering the burst mode, there is still a full control of the power conversion to the output through the optocoupler, that is used for the normal PWM control. The response on load jumps is optimized and the voltage ripple on  $V_{out}$  is minimized. The  $V_{out}$  is on well controlled in this mode.

The usually external connected RC-filter in the feedback line after the optocoupler is integrated in the IC to reduce the external part count.

Adopting the BiCMOS technology, it can increase the design flexibility as the  $V_{CC}$  voltage range is increased to 25V.

It has a built-in 20ms soft start function.

There are 2 modes of blanking time for high load jumps; the basic mode and the extendable mode. The blanking time for the basic mode is set at 20ms while the extendable mode will increase the blanking time by adding an external capacitor at the BA pin in addition to the basic mode blanking time. During this blanking time window the system can give the maximum power to the loading.

In order to increase the robustness and safety of the system, the IC provides Auto Restart protection. The Auto Restart Mode reduces the average power conversion to a minimum level under unsafe operating

conditions. This is necessary for a prolonged fault condition which could otherwise lead to a destruction of the SMPS over time. Once the malfunction is removed, normal operation is automatically retained after the next Start Up Phase. To make the protection more flexible, an external auto-restart enable pin is provided. When the pin is triggered, the switching pulse at gate will stop and the IC enters the auto-restart mode after the pre-defined spike blanking time.

The internal precise peak current control reduces the costs for the transformer and the secondary diode. The influence of the change in the input voltage on the maximum power limitation can be avoided together with the integrated Propagation Delay Compensation. Therefore the maximum power is nearly independent on the input voltage, which is required for wide range SMPS. Thus there is no need for the over-sizing of the SMPS, e.g. the transformer and the output diode.

Furthermore, it implements the frequency jitter mode to the switching clock such that the EMI noise will be effectively reduced.

#### 3.2 Power Management

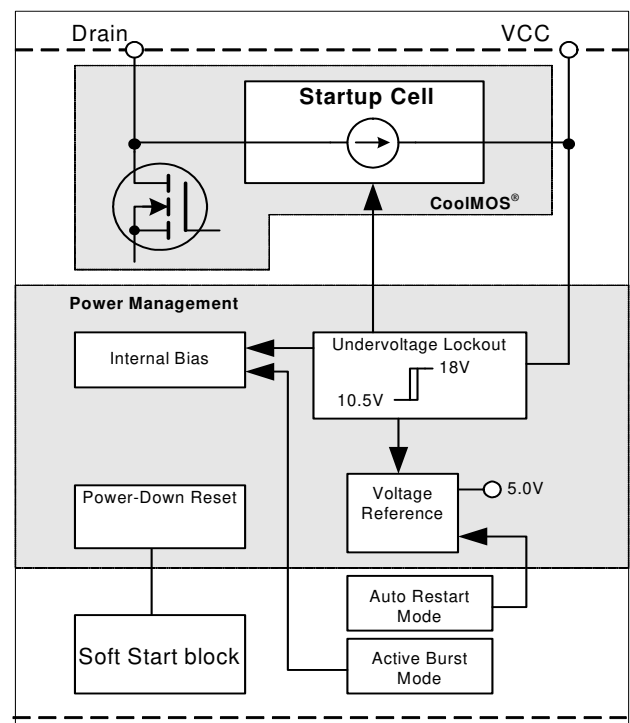


Figure 3 Power Management

The Undervoltage Lockout monitors the external supply voltage  $V_{VCC}$ . When the SMPS is plugged to the main line the internal Startup Cell is biased and starts to charge the external capacitor  $C_{VCC}$  which is connected to the VCC pin. This VCC charge current is

## Functional Description

controlled to 0.9mA by the Startup Cell. When the  $V_{VCC}$  exceeds the on-threshold  $V_{CCon}=18V$  the bias circuit are switched on. Then the Startup Cell is switched off by the Undervoltage Lockout and therefore no power losses present due to the connection of the Startup Cell to the Drain voltage. To avoid uncontrolled ringing at switch-on, a hysteresis start up voltage is implemented. The switch-off of the controller can only take place when  $V_{VCC}$  falls below 10.5V after normal operation was entered. The maximum current consumption before the controller is activated is about 150 $\mu$ A.

When  $V_{VCC}$  falls below the off-threshold  $V_{CCoff}=10.5V$ , the bias circuit is switched off and the soft start counter is reset. Thus it is ensured that at every startup cycle the soft start starts at zero.

The internal bias circuit is switched off if Auto Restart Mode is entered. The current consumption is then reduced to 150 $\mu$ A.

Once the malfunction condition is removed, this block will then turn back on. The recovery from Auto Restart Mode does not require re-cycling the AC line.

When Active Burst Mode is entered, the internal Bias is switched off most of the time but the Voltage Reference is kept alive in order to reduce the current consumption below 450 $\mu$ A.

### 3.3 Improved Current Mode

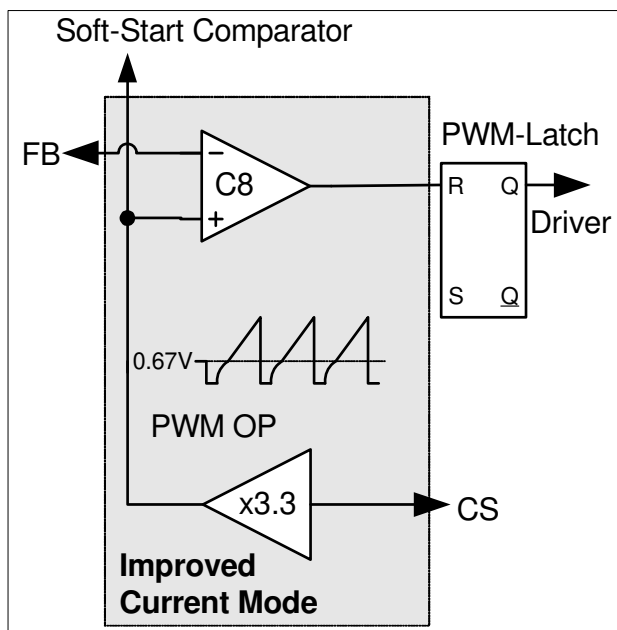


Figure 4 Current Mode

Current Mode means the duty cycle is controlled by the slope of the primary current. This is done by comparing the FB signal with the amplified current sense signal.

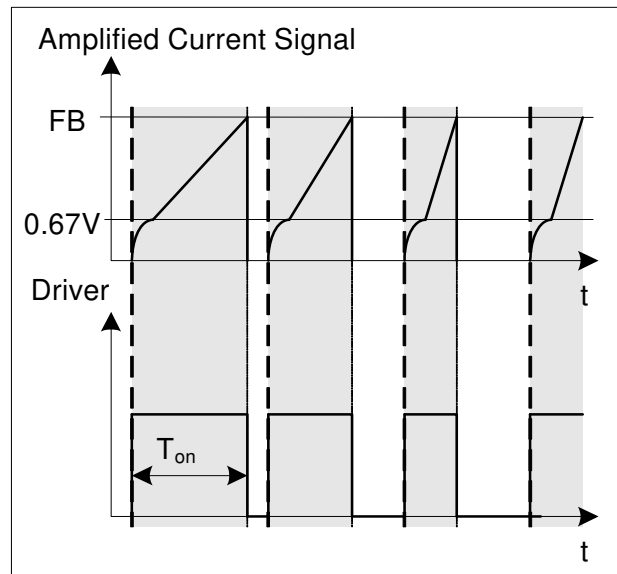


Figure 5 Pulse Width Modulation

In case the amplified current sense signal exceeds the FB signal the on-time  $T_{on}$  of the driver is finished by resetting the PWM-Latch (see Figure 5).

The primary current is sensed by the external series resistor  $R_{Sense}$  inserted in the source of the integrated CoolMOS<sup>®</sup>. By means of Current Mode regulation, the secondary output voltage is insensitive to the line variations. The current waveform slope will change with the line variation, which controls the duty cycle.

The external  $R_{Sense}$  allows an individual adjustment of the maximum source current of the integrated CoolMOS<sup>®</sup>.

To improve the Current Mode during light load conditions the amplified current ramp of the PWM-OP is superimposed on a voltage ramp, which is built by the switch T2, the voltage source V1 and a resistor R1 (see Figure 6). Every time the oscillator shuts down for maximum duty cycle limitation the switch T2 is closed by  $V_{OSC}$ . When the oscillator triggers the Gate Driver, T2 is opened so that the voltage ramp can start.

In case of light load the amplified current ramp is too small to ensure a stable regulation. In that case the Voltage Ramp is a well defined signal for the comparison with the FB-signal. The duty cycle is then controlled by the slope of the Voltage Ramp.

By means of the time delay circuit which is triggered by the inverted  $V_{OSC}$  signal, the Gate Driver is switched-off until it reaches approximately 156ns delay time (see Figure 7). It allows the duty cycle to be reduced continuously till 0% by decreasing  $V_{FB}$  below that threshold.

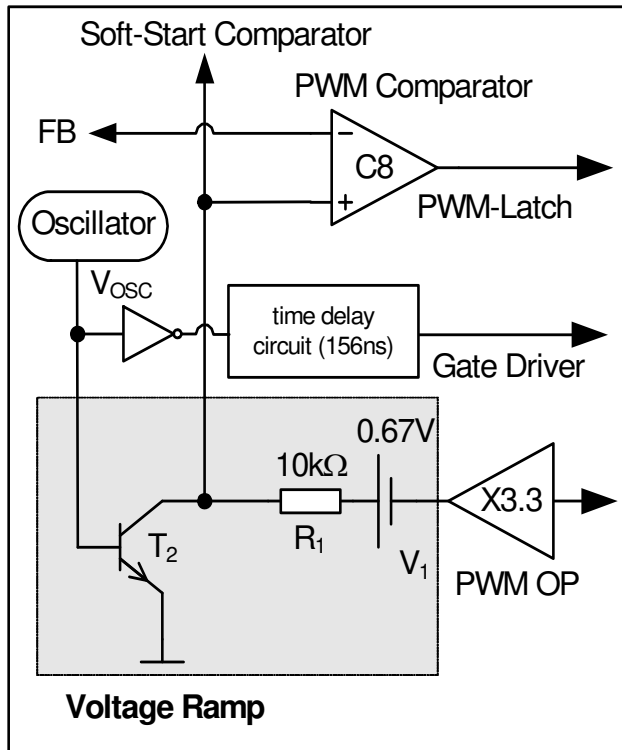
**Functional Description**


Figure 6 Improved Current Mode

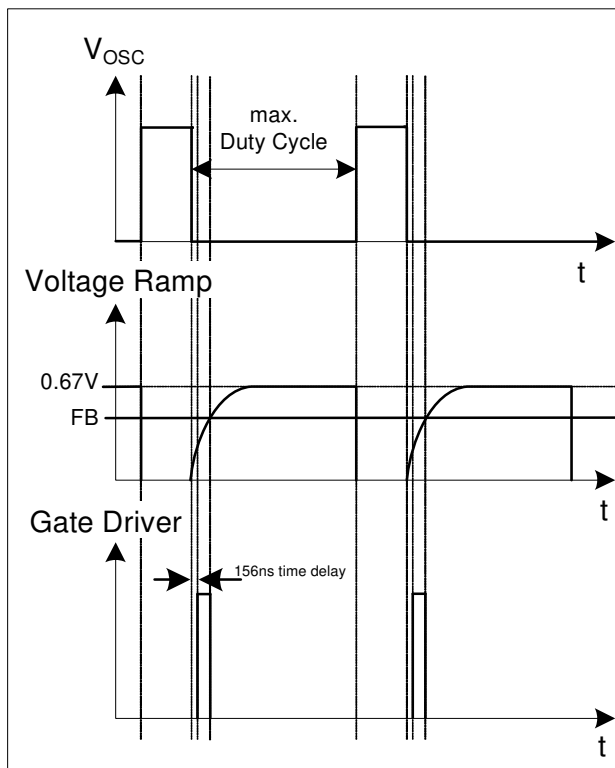


Figure 7 Light Load Conditions

**3.3.1 PWM-OP**

The input of the PWM-OP is applied over the internal leading edge blanking to the external sense resistor  $R_{Sense}$  connected to pin CS.  $R_{Sense}$  converts the source current into a sense voltage. The sense voltage is amplified with a gain of 3.3 by PWM OP. The output of the PWM-OP is connected to the voltage source  $V_1$ . The voltage ramp with the superimposed amplified current signal is fed into the positive inputs of the PWM-Comparator C8 and the Soft-Start-Comparator (see Figure 6).

**3.3.2 PWM-Comparator**

The PWM-Comparator compares the sensed current signal of the integrated CoolMOS<sup>®</sup> with the feedback signal  $V_{FB}$  (see Figure 8).  $V_{FB}$  is created by an external optocoupler or external transistor in combination with the internal pull-up resistor  $R_{FB}$  and provides the load information of the feedback circuitry. When the amplified current signal of the integrated CoolMOS<sup>®</sup> exceeds the signal  $V_{FB}$  the PWM-Comparator switches off the Gate Driver.

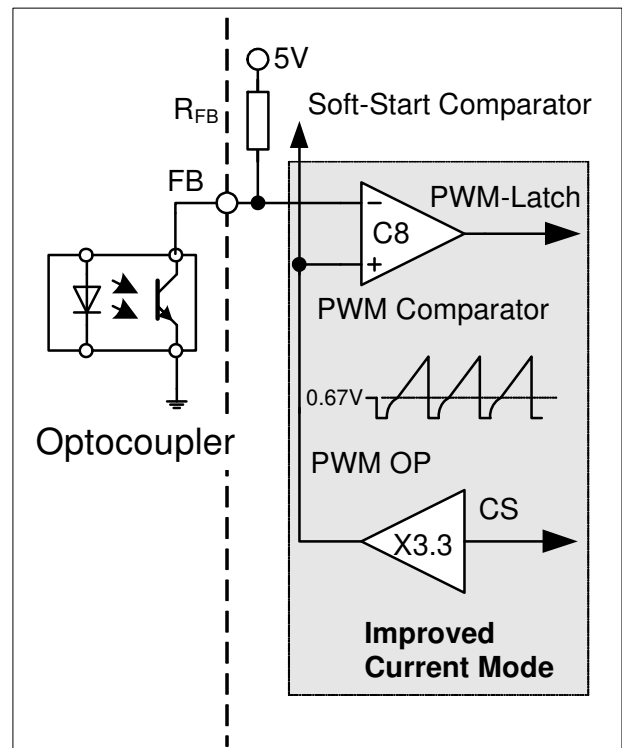


Figure 8 PWM Controlling

## Functional Description

### 3.4 Startup Phase

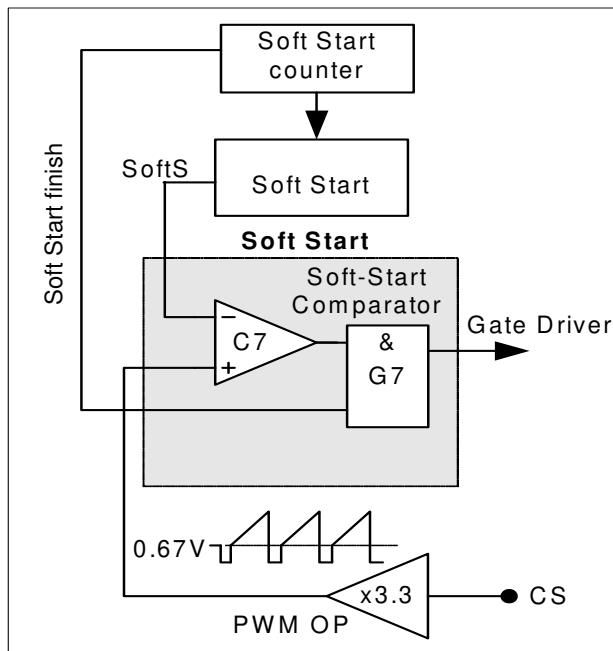


Figure 9 Soft Start

In the Startup Phase, the IC provides a Soft Start period to control the primary current by means of a duty cycle limitation. The Soft Start function is a built-in function and it is controlled by an internal counter.

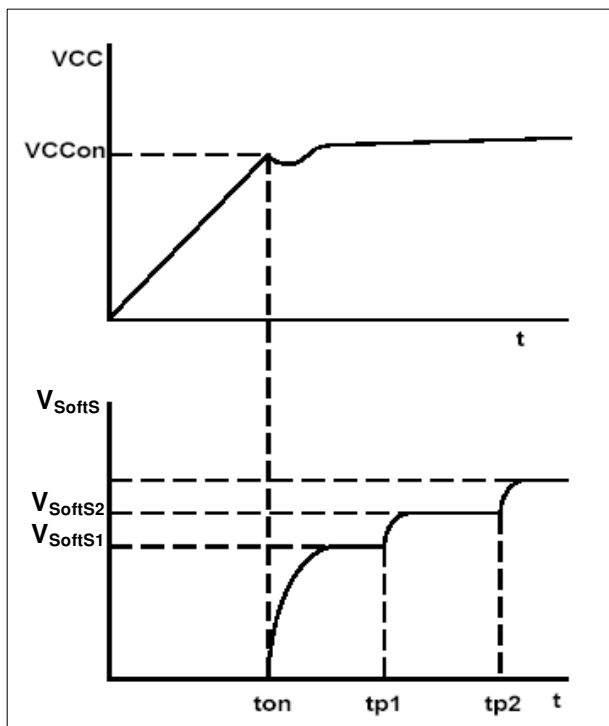


Figure 10 Soft Start Phase

When the  $V_{VCC}$  exceeds the on-threshold voltage, the IC starts the Soft Start mode (see Figure 10).

The function is realized by an internal Soft Start resistor, an current sink and a counter. And the amplitude of the current sink is controlled by the counter (see Figure 11).

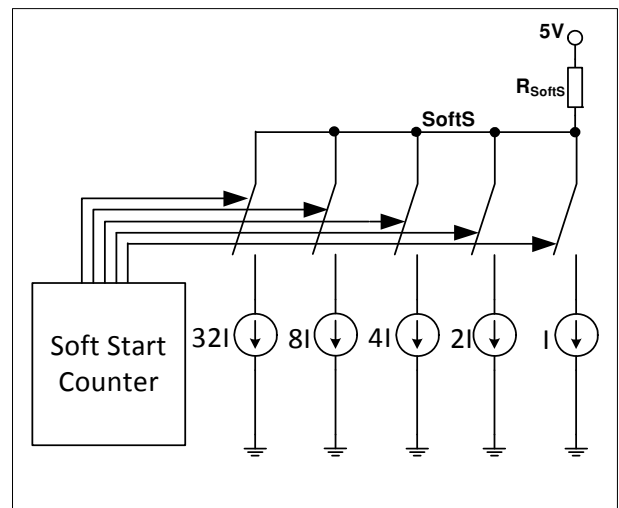


Figure 11 Soft Start Circuit

After the IC is switched on, the  $V_{SFOFTS}$  voltage is controlled such that the voltage is increased stepwisely (32 steps) with the increase of the counts. The Soft Start counter would send a signal to the current sink control in every 600us such that the current sink decrease gradually and the duty ratio of the gate drive increases gradually. The Soft Start will be finished in 20ms ( $T_{Soft-Start}$ ) after the IC is switched on. At the end of the Soft Start period, the current sink is switched off.

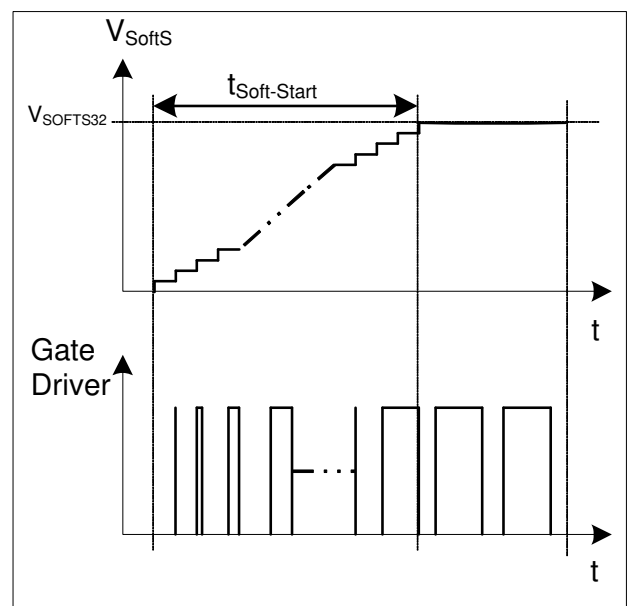


Figure 12 Gate drive signal under Soft-Start Phase

## Functional Description

Within the soft start period, the duty cycle is increasing from zero to maximum gradually (see Figure 12).

In addition to Start-Up, Soft-Start is also activated at each restart attempt during Auto Restart.

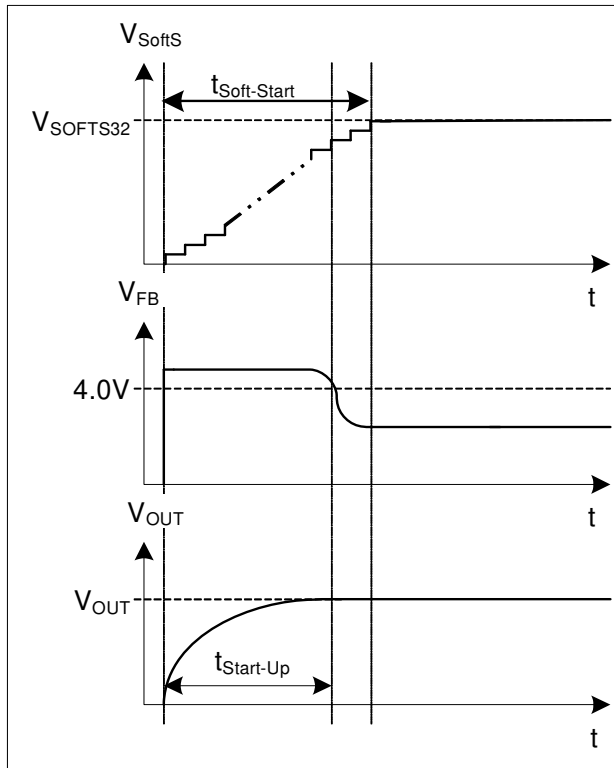


Figure 13 Start Up Phase

The Start-Up time  $T_{\text{Start-Up}}$  before the converter output voltage  $V_{\text{OUT}}$  is settled, must be shorter than the Soft-Start Phase  $T_{\text{Soft-Start}}$  (see Figure 13).

By means of Soft-Start there is an effective minimization of current and voltage stresses on the integrated CoolMOS<sup>®</sup>, the clamp circuit and the output overshoot and it helps to prevent saturation of the transformer during Start-Up.

### 3.5 PWM Section

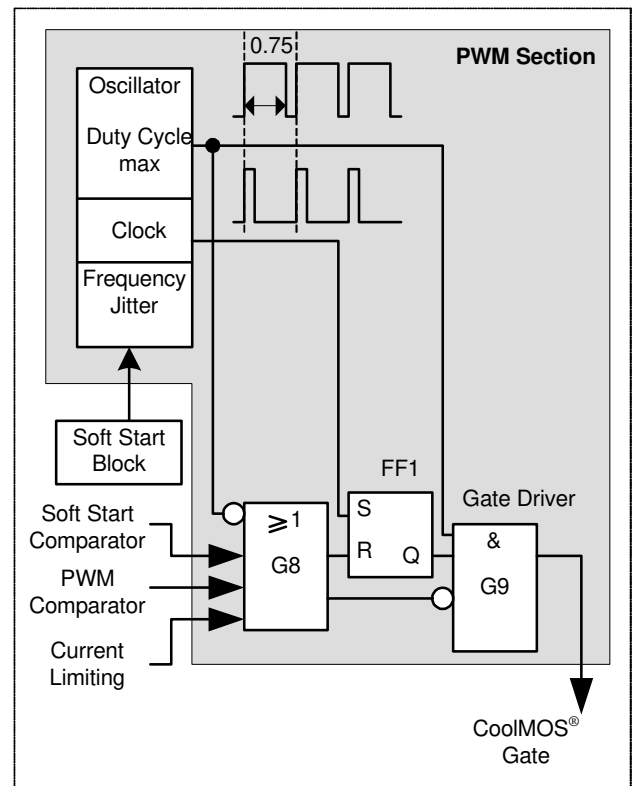


Figure 14 PWM Section Block

#### 3.5.1 Oscillator

The oscillator generates a fixed frequency of 65KHz with frequency jittering of  $\pm 4\%$  (which is  $\pm 2.6\text{KHz}$ ) at a jittering period of 4ms.

A capacitor, a current source and current sink which determine the frequency are integrated. In order to achieve a very accurate switching frequency, the charging and discharging current of the implemented oscillator capacitor are internally trimmed. The ratio of controlled charge to discharge current is adjusted to reach a maximum duty cycle limitation of  $D_{\text{max}}=0.75$ .

Once the Soft Start period is over and when the IC goes into normal operating mode, the switching frequency of the clock is varied by the control signal from the Soft Start block. Then the switching frequency is varied in range of  $65\text{KHz} \pm 2.6\text{KHz}$  at period of 4ms.

#### 3.5.2 PWM-Latch FF1

The output of the oscillator block provides continuous pulse to the PWM-Latch which turns on/off the integrated CoolMOS<sup>®</sup>. After the PWM-Latch is set, it is reset by the PWM comparator, the Soft Start comparator or the Current-Limit comparator. When it is in reset mode, the output of the driver is shut down immediately.





## Functional Description

### 3.6.1 Leading Edge Blanking

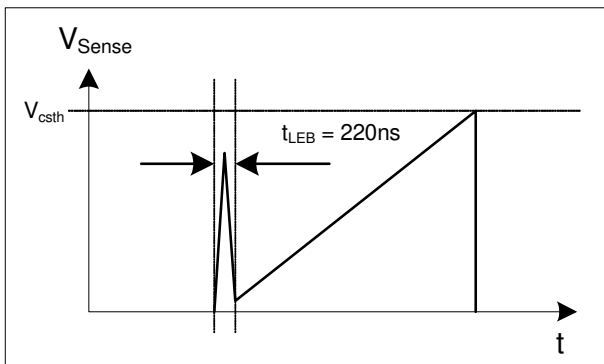


Figure 18 Leading Edge Blanking

Whenever the integrated CoolMOS<sup>®</sup> is switched on, a leading edge spike is generated due to the primary-side capacitances and reverse recovery time of the secondary-side rectifier. This spike can cause the gate drive to switch off unintentionally. In order to avoid a premature termination of the switching pulse, this spike is blanked out with a time constant of  $t_{LEB} = 220\text{ns}$ .

### 3.6.2 Propagation Delay Compensation

In case of over-current detection, there is always propagation delay to switch off the integrated CoolMOS<sup>®</sup>. An overshoot of the peak current  $I_{peak}$  is induced to the delay, which depends on the ratio of  $dI/dt$  of the peak current (see Figure 19).

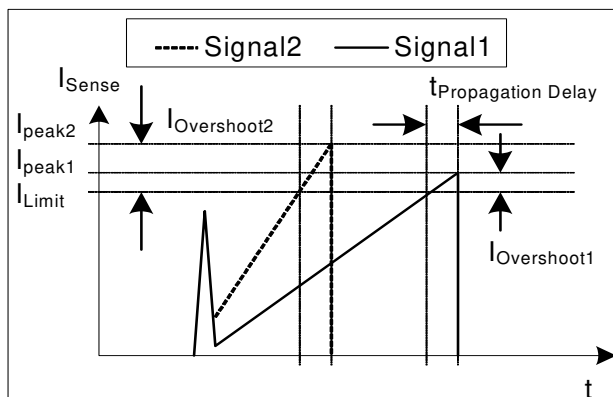


Figure 19 Current Limiting

The overshoot of Signal2 is larger than of Signal1 due to the steeper rising waveform. This change in the slope depends on the AC input voltage. Propagation Delay Compensation is integrated to reduce the overshoot due to  $dI/dt$  of the rising primary current. Thus the propagation delay time between exceeding the current sense threshold  $V_{csth}$  and the switching off of the integrated CoolMOS<sup>®</sup> is compensated over temperature within a wide range. Current Limiting is then very accurate.

For example,  $I_{peak} = 0.5\text{A}$  with  $R_{Sense} = 2$ . The current sense threshold is set to a static voltage level  $V_{csth} = 1\text{V}$  without Propagation Delay Compensation. A current ramp of  $dI/dt = 0.4\text{A}/\mu\text{s}$ , or  $dV_{Sense}/dt = 0.8\text{V}/\mu\text{s}$ , and a propagation delay time of  $t_{Propagation Delay} = 180\text{ns}$  leads to an  $I_{peak}$  overshoot of 14.4%. With the propagation delay compensation, the overshoot is only around 2% (see Figure 20).

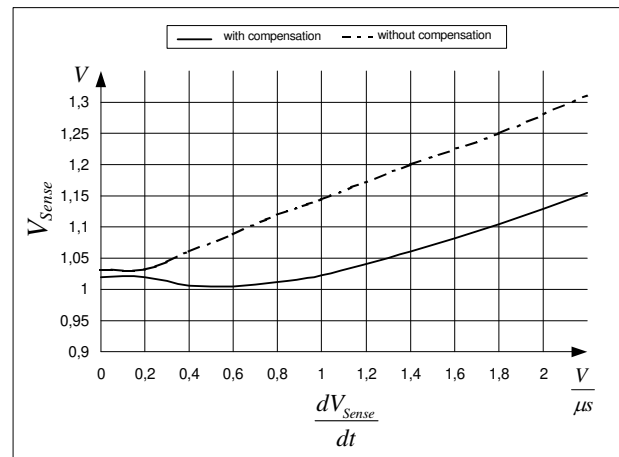


Figure 20 Overcurrent Shutdown

The Propagation Delay Compensation is realized by means of a dynamic threshold voltage  $V_{csth}$  (see Figure 21). In case of a steeper slope the switch off of the driver is earlier to compensate the delay.

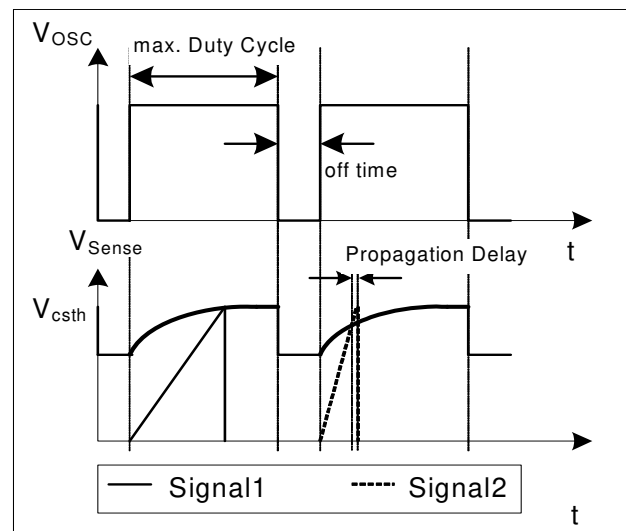


Figure 21 Dynamic Voltage Threshold  $V_{csth}$

## Functional Description

### 3.7 Control Unit

The Control Unit contains the functions for Active Burst Mode and Auto Restart Mode. The Active Burst Mode and the Auto Restart Mode both have 20ms internal Blanking Time. For the Auto Restart Mode, a further extendable Blanking Time is achieved by adding external capacitor at BA pin. By means of this Blanking Time, the IC avoids entering into these two modes accidentally. Furthermore those buffer time for the overload detection is very useful for the application that works in low current but requires a short duration of high current occasionally.

#### 3.7.1 Basic and Extendable Blanking Mode

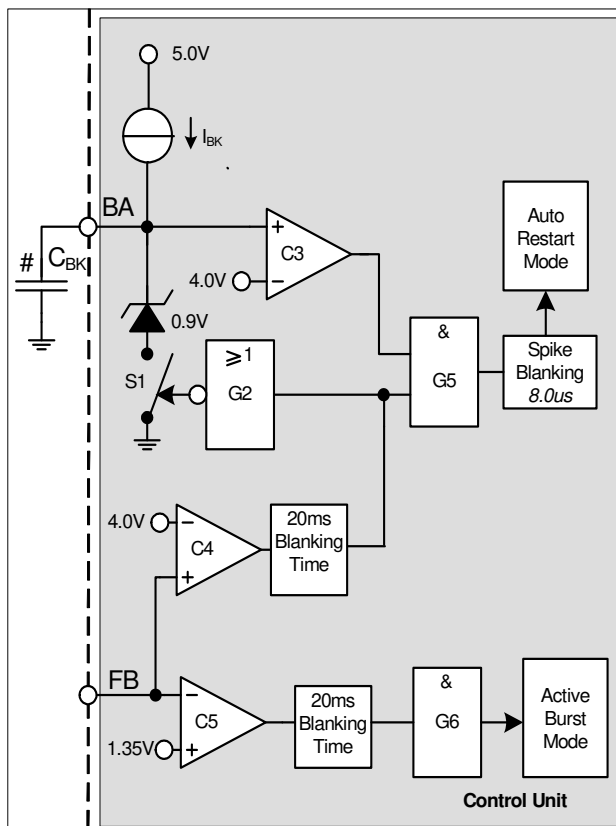


Figure 22 Basic and Extendable Blanking Mode

There are 2 kinds of Blanking mode; basic mode and the extendable mode. The basic mode is just an internal set 20ms blanking time while the extendable mode has an extra blanking time by connecting an external capacitor to the BA pin in addition to the pre-set 20ms blanking time. For the extendable mode, the gate G5 is blocked even though the 20ms blanking time is reached if an external capacitor  $C_{BK}$  is added to BA pin. While the 20ms blanking time is passed, the switch S1 is opened by G2. Then the 0.9V clamped voltage at BA pin is charged to 4.0V through the internal  $I_{BK}$  constant current. G5 is enabled by comparator C3.

After the 30us spike blanking time, the Auto Restart Mode is activated.

For example, if  $C_{BK} = 0.22\mu\text{F}$ ,  $I_{BK} = 13\mu\text{A}$

Blanking time =  $20\text{ms} + C_{BK} \times (4.0 - 0.9) / I_{BK} = 72\text{ms}$

In order to make the startup properly, the maximum  $C_{BK}$  capacitor is restricted to less than 0.65uF.

The Active Burst Mode has basic blanking mode only while the Auto Restart Mode has both the basic and the extendable blanking mode.

#### 3.7.2 Active Burst Mode

The IC enters Active Burst Mode under low load conditions. With the Active Burst Mode, the efficiency increases significantly at light load conditions while still maintaining a low ripple on  $V_{OUT}$  and a fast response on load jumps. During Active Burst Mode, the IC is controlled by the FB signal. Since the IC is always active, it can be a very fast response to the quick change at the FB signal. The Start up Cell is kept OFF in order to minimize the power loss.

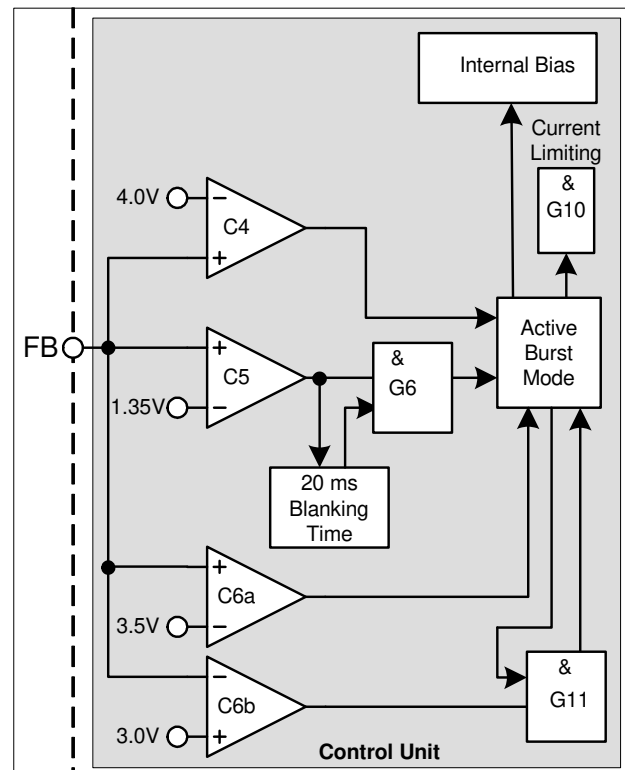


Figure 23 Active Burst Mode

The Active Burst Mode is located in the Control Unit. Figure 23 shows the related components.

#### 3.7.2.1 Entering Active Burst Mode

The FB signal is kept monitoring by the comparator C5. During normal operation, the internal blanking time counter is reset to 0. Once the FB signal falls below 1.35V, it starts to count. When the counter reach 20ms

## Functional Description

and FB signal is still below 1.35V, the system enters the Active Burst Mode. This time window prevents a sudden entering into the Active Burst Mode due to large load jumps.

After entering Active Burst Mode, a burst flag is set and the internal bias is switched off in order to reduce the current consumption of the IC to approx. 450uA.

It needs the application to enforce the VCC voltage above the Undervoltage Lockout level of 10.5V such that the Startup Cell will not be switched on accidentally. Or otherwise the power loss will increase drastically. The minimum VCC level during Active Burst Mode depends on the load condition and the application. The lowest VCC level is reached at no load condition.

### 3.7.2.2 Working in Active Burst Mode

After entering the Active Burst Mode, the FB voltage rises as  $V_{OUT}$  starts to decrease, which is due to the inactive PWM section. The comparator C6a monitors the FB signal. If the voltage level is larger than 3.5V, the internal circuit will be activated; the Internal Bias circuit resumes and starts to provide switching pulse. In Active Burst Mode the gate G10 is released and the current limit is reduced to 0.34V, which can reduce the conduction loss and the audible noise. If the load at  $V_{OUT}$  is still kept unchanged, the FB signal will drop to 3.0V. At this level the C6b deactivates the internal circuit again by switching off the internal Bias. The gate G11 is active again as the burst flag is set after entering Active Burst Mode. In Active Burst Mode, the FB voltage is changing like a saw tooth between 3.0V and 3.5V (see figure 24).

### 3.7.2.3 Leaving Active Burst Mode

The FB voltage will increase immediately if there is a high load jump. This is observed by the comparator C4. Since the current limit is app. 34% during Active Burst Mode, it needs a certain load jump to rise the FB signal to exceed 4.0V. At that time the comparator C4 resets the Active Burst Mode control which in turn blocks the comparator C12 by the gate G10. The maximum current can then be resumed to stabilize the  $V_{OUT}$ .

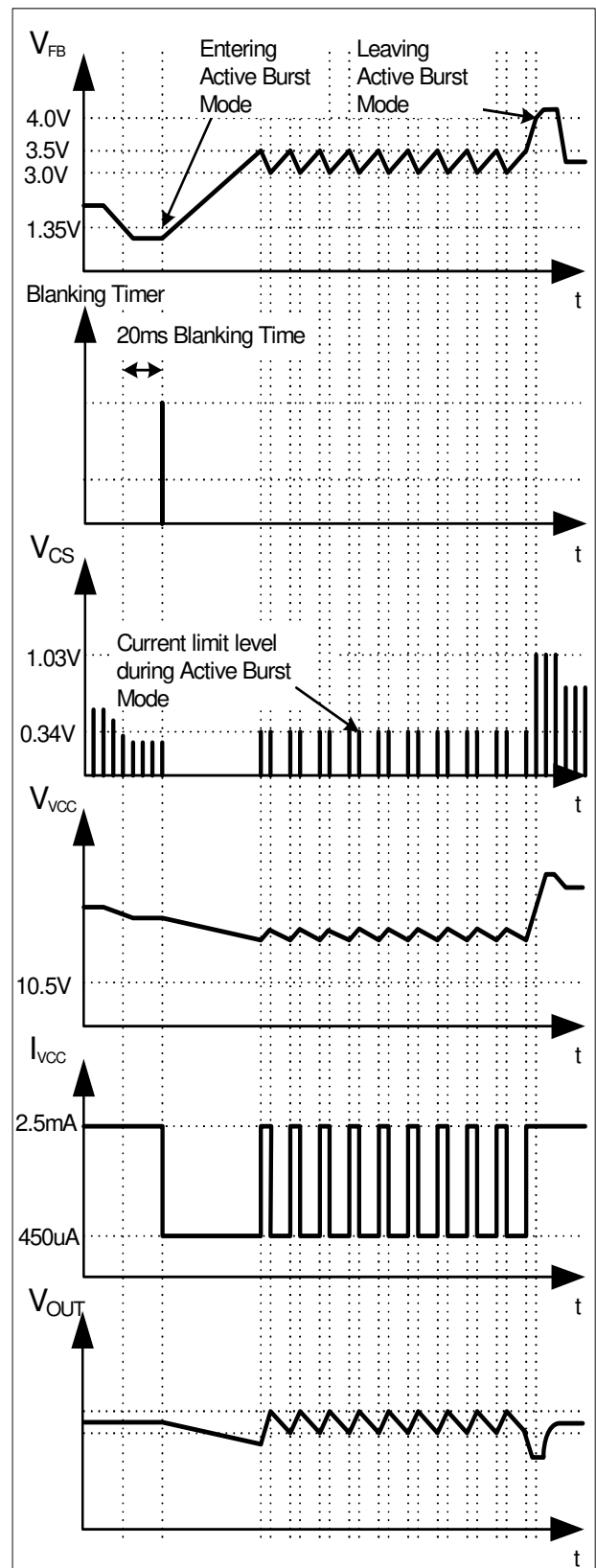


Figure 24 Signals in Active Burst Mode

Functional Description

3.7.3 Protection Modes

The IC provides Auto Restart Mode as the protection feature. Auto Restart mode can prevent the SMPS from destructive states. The following table shows the relationship between possible system failures and the corresponding protection modes.

VCC Overvoltage	Auto Restart Mode
Overtemperature	Auto Restart Mode
Overload	Auto Restart Mode
Open Loop	Auto Restart Mode
VCC Undervoltage	Auto Restart Mode
Short Optocoupler	Auto Restart Mode
Auto restart enable	Auto Restart Mode

Before entering the Auto Restart protection mode, some of the protections can have extended blanking time to delay the protection and some needs to fast react and will go straight to the protection. Overload and open loop protection are the one can have extended blanking time while Vcc Overvoltage, Over temperature, Vcc Undervoltage, short opto-coupler and external auto restart enable will go to protection right away.

After the system enters the Auto-restart mode, the IC will be off. Since there is no more switching, the Vcc voltage will drop. When it hits the Vcc turn off threshold, the start up cell will turn on and the Vcc is charged by the startup cell current to Vcc turn on threshold. The IC is on and the startup cell will turn off. At this stage, it will enter the startup phase (soft start) with switching cycles. After the Start Up Phase, the fault condition is checked. If the fault condition persists, the IC will go to auto restart mode again. If, otherwise, the fault is removed, normal operation is resumed.

3.7.3.1 Auto Restart mode with extended blanking time

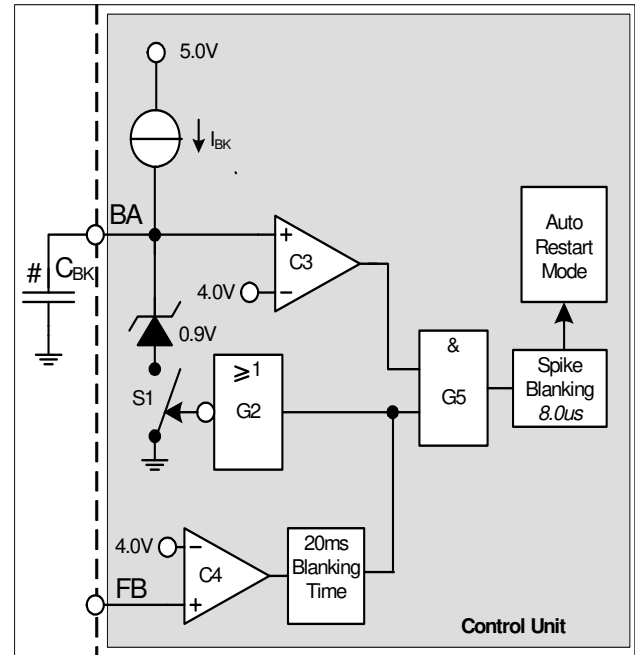


Figure 25 Auto Restart Mode

In case of Overload or Open Loop, the FB exceeds 4.0V which will be observed by comparator C4. Then the internal blanking counter starts to count. When it reaches 20ms, the switch S1 is released. Then the clamped voltage 0.9V at  $V_{BA}$  can increase. When there is no external capacitor  $C_{BK}$  connected, the  $V_{BA}$  will reach 4.0V immediately. When both the input signals at AND gate G5 is positive, the Auto Restart Mode will be activated after the extra spike blanking time of 30us is elapsed. However, when an extra blanking time is needed, it can be achieved by adding an external capacitor,  $C_{BK}$ . A constant current source of  $I_{BK}$  will start to charge the capacitor  $C_{BK}$  from 0.9V to 4.0V after the switch S1 is released. The charging time from 0.9V to 4.0V are the extendable blanking time. If  $C_{BK}$  is 0.22uF and  $I_{BK}$  is 13uA, the extendable blanking time is around 52ms and the total blanking time is 72ms. In combining the FB and blanking time, there is a blanking window generated which prevents the system to enter Auto Restart Mode due to large load jumps.

## Functional Description

### 3.7.3.2 Auto Restart without extended blanking time

up cell will turn on automatically. And this leads to Auto Restart Mode.

Short Optocoupler also leads to VCC undervoltage as there is no self supply after activating the internal reference and bias.

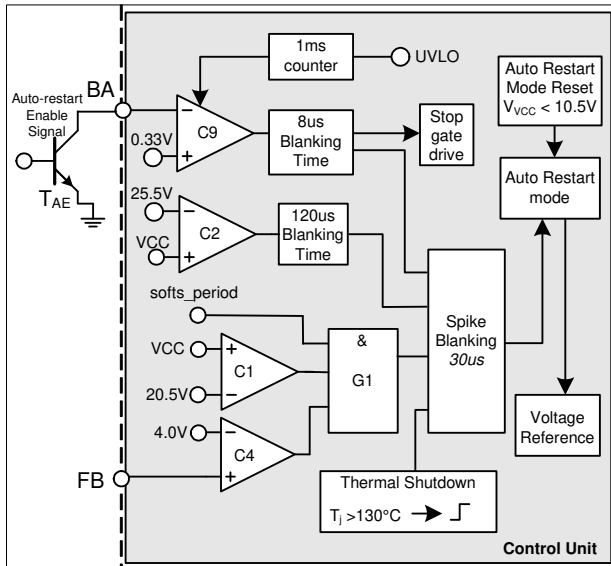


Figure 26 Auto Restart mode

There are 2 modes of  $V_{CC}$  overvoltage protection; one is during soft start and the other is at all conditions.

The first one is  $V_{VCC}$  voltage is  $> 20.5V$  and  $FB$  is  $> 4.0V$  and during soft\_start period and the IC enters Auto Restart Mode. The  $V_{CC}$  voltage is observed by comparator C1 and C4. The fault conditions are to detect the abnormal operating during start up such as open loop during light load start up, etc. The logic can eliminate the possible of entering Auto Restart mode if there is a small voltage overshoots of  $V_{VCC}$  during normal operating.

The 2nd one is  $V_{VCC} > 25.5V$  and last for 120us and the IC enters Auto Restart Mode. This 25.5V  $V_{CC}$  OVP protection is inactivated during burst mode.

The Thermal Shutdown block monitors the junction temperature of the IC. After detecting a junction temperature higher than  $130^{\circ}C$ , the Auto Restart Mode is entered.

In case the pre-defined auto-restart features are not sufficient, there is a customer defined external Auto-restart Enable feature. This function can be triggered by pulling down the BA pin to  $< 0.33V$ . It can simply add a trigger signal to the base of the externally added transistor,  $T_{AE}$  at the BA pin. When the function is enabled, the gate drive switching will be stopped and then the IC will enter auto-restart mode if the signal persists. To ensure this auto-restart function will not be mis-triggered during start up, a 1ms delay time is implemented to blank the unstable signal.

$V_{CC}$  undervoltage is the  $V_{CC}$  voltage drop below  $V_{CC}$  turn off threshold. Then the IC will turn off and the start

## 4 Electrical Characteristics

Note: All voltages are measured with respect to ground (Pin 8). The voltage levels are valid if other ratings are not violated.

### 4.1 Absolute Maximum Ratings

Note: Absolute maximum ratings are defined as ratings, which when being exceeded may lead to destruction of the integrated circuit. For the same reason make sure, that any capacitor that will be connected to pin 7 (VCC) is discharged before assembling the application circuit.  $T_a=25^\circ\text{C}$  unless otherwise specified.

Parameter	Symbol	Limit Values		Unit	Remarks
		min.	max.		
Switching drain current, pulse width $t_p$ limited by $T_j=150^\circ\text{C}$	$I_s$	-	4.03	A	
Pulse drain current, pulse width $t_p$ limited by $T_j=150^\circ\text{C}$	$I_{D\_Puls}$	-	6.12	A	
Avalanche energy, repetitive $t_{AR}$ limited by max. $T_j=150^\circ\text{C}^{1)}$	$E_{AR}$	-	0.15	mJ	
Avalanche current, repetitive $t_{AR}$ limited by max. $T_j=150^\circ\text{C}^{1)}$	$I_{AR}$	-	1.5	A	
VCC Supply Voltage	$V_{VCC}$	-0.3	27	V	
FB Voltage	$V_{FB}$	-0.3	5.5	V	
BA Voltage	$V_{BA}$	-0.3	5.5	V	
CS Voltage	$V_{CS}$	-0.3	5.5	V	
Junction Temperature	$T_j$	-40	150	$^\circ\text{C}$	Controller & CoolMOS <sup>®</sup>
Storage Temperature	$T_S$	-55	150	$^\circ\text{C}$	
Thermal Resistance Junction -Ambient	$R_{thJA}$	-	96	K/W	
Soldering temperature, wavesoldering only allowed at leads	$T_{sold}$	-	260	$^\circ\text{C}$	1.6mm (0.063in.) from case for 10s
ESD Capability (incl. Drain Pin)	$V_{ESD}$	-	2	kV	Human body model <sup>2)</sup>

<sup>1)</sup> Repetitive avalanche causes additional power losses that can be calculated as  $P_{AV}=E_{AR} \cdot f$

<sup>2)</sup> According to EIA/JESD22-A114-B (discharging a 100pF capacitor through a 1.5k $\Omega$  series resistor)



## Electrical Characteristics

### 4.2 Operating Range

Note: Within the operating range the IC operates as described in the functional description.

Parameter	Symbol	Limit Values		Unit	Remarks
		min.	max.		
VCC Supply Voltage	$V_{VCC}$	$V_{VCCoff}$	25	V	Max value limited due to Vcc OVP
Junction Temperature of Controller	$T_{jCon}$	-40	130	°C	Max value limited due to thermal shut down of controller
Junction Temperature of CoolMOS®	$T_{jCoolMOS}$	-40	150	°C	

### 4.3 Characteristics

#### 4.3.1 Supply Section

Note: The electrical characteristics involve the spread of values within the specified supply voltage and junction temperature range  $T_j$  from -40 °C to 125 °C. Typical values represent the median values, which are related to 25°C. If not otherwise stated, a supply voltage of  $V_{CC} = 18 V$  is assumed.

Parameter	Symbol	Limit Values			Unit	Test Condition
		min.	typ.	max.		
Start Up Current	$I_{VCCstart}$	-	150	250	µA	$V_{VCC} = 17V$
VCC Charge Current	$I_{VCCcharge1}$	-	-	5.0	mA	$V_{VCC} = 0V$
	$I_{VCCcharge2}$	0.55	0.9	1.60	mA	$V_{VCC} = 1V$
	$I_{VCCcharge3}$	-	0.7	-	mA	$V_{VCC} = 17V$
Leakage Current of Start Up Cell and CoolMOS®	$I_{StartLeak}$	-	0.2	50	µA	$V_{Drain} = 450V$ at $T_j = 100°C$
Supply Current with Inactive Gate	$I_{VCCsup1}$	-	1.5	2.5	mA	
Supply Current with Active Gate	$I_{VCCsup2}$	-	2.7	3.4	mA	$I_{FB} = 0A$
Supply Current in Auto Restart Mode with Inactive Gate	$I_{VCCrestart}$	-	250	-	µA	$I_{FB} = 0A$
Supply Current in Active Burst Mode with Inactive Gate	$I_{VCCburst1}$	-	450	950	µA	$V_{FB} = 2.5V$
	$I_{VCCburst2}$	-	450	950	µA	$V_{VCC} = 11.5V, V_{FB} = 2.5V$
VCC Turn-On Threshold	$V_{VCCon}$	17.0	18.0	19.0	V	
VCC Turn-Off Threshold	$V_{VCCoff}$	9.8	10.5	11.2	V	
VCC Turn-On/Off Hysteresis	$V_{VChys}$	-	7.5	-	V	

**Electrical Characteristics**
**4.3.2 Internal Voltage Reference**

Parameter	Symbol	Limit Values			Unit	Test Condition
		min.	typ.	max.		
Trimmed Reference Voltage	$V_{REF}$	4.90	5.00	5.10	V	measured at pin FB $I_{FB} = 0$

**4.3.3 PWM Section**

Parameter	Symbol	Limit Values			Unit	Test Condition
		min.	typ.	max.		
Fixed Oscillator Frequency	$f_{OSC1}$	54.5	65.0	73.5	kHz	$T_j = 25^\circ\text{C}$
	$f_{OSC2}$	59.8	65.0	70.2		
Frequency Jittering Range	$f_{jitter}$	-	$\pm 2.6$	-	kHz	$T_j = 25^\circ\text{C}$
Frequency Jittering period	$T_{jitter}$	-	4.0	-	ms	$T_j = 25^\circ\text{C}$
Max. Duty Cycle	$D_{max}$	0.70	0.75	0.80		
Min. Duty Cycle	$D_{min}$	0	-	-		$V_{FB} < 0.3\text{V}$
PWM-OP Gain	$A_V$	3.1	3.3	3.5		
Voltage Ramp Offset	$V_{Offset-Ramp}$	-	0.67	-	V	
$V_{FB}$ Operating Range Min Level	$V_{FBmin}$	-	0.5	-	V	
$V_{FB}$ Operating Range Max level	$V_{FBmax}$	-	-	4.3	V	CS=1V, limited by Comparator C4 <sup>1)</sup>
FB Pull-Up Resistor	$R_{FB}$	9	15.4	23	k $\Omega$	

<sup>1)</sup> The parameter is not subjected to production test - verified by design/characterization

**4.3.4 Soft Start time**

Parameter	Symbol	Limit Values			Unit	Test Condition
		min.	typ.	max.		
Soft Start time	$t_{SS}$	-	20.0	-	ms	

**Electrical Characteristics**
**4.3.5 Control Unit**

Parameter	Symbol	Limit Values			Unit	Test Condition
		min.	typ.	max.		
Clamped $V_{BA}$ voltage during Normal Operating Mode	$V_{BAclmp}$	0.85	0.9	0.95	V	$V_{FB} = 4V$
Blanking time voltage limit for Comparator C3	$V_{BKC3}$	3.85	4.00	4.15	V	
Over Load & Open Loop Detection Limit for Comparator C4	$V_{FBC4}$	3.85	4.00	4.15	V	
Active Burst Mode Level for Comparator C5	$V_{FBC5}$	1.25	1.35	1.45	V	
Active Burst Mode Level for Comparator C6a	$V_{FBC6a}$	3.35	3.50	3.65	V	After Active Burst Mode is entered
Active Burst Mode Level for Comparator C6b	$V_{FBC6b}$	2.88	3.00	3.12	V	After Active Burst Mode is entered
Overvoltage Detection Limit for Comparator C1	$V_{VCCOVP1}$	19.5	20.5	21.5	V	$V_{FB} = 5V$
Overvoltage Detection Limit for Comparator C2	$V_{VCCOVP2}$	25.0	25.5	26.5	V	
Auto-restart Enable level at BA pin	$V_{AE}$	0.25	0.33	0.4	V	>30 $\mu$ s
Charging current at BA pin	$I_{BK}$	9.5	13.0	16.9	$\mu$ A	Charge starts after the built-in 20ms blanking time elapsed
Thermal Shutdown <sup>1)</sup>	$T_{JSD}$	130	140	150	$^{\circ}$ C	Controller
Built-in Blanking Time for Overload Protection or enter Active Burst Mode	$t_{BK}$	-	20	-	ms	without external capacitor at BA pin
Inhibit Time for Auto-Restart enable function during start up	$t_{IHAE}$	-	1.0	-	ms	Count when $V_{CC} > 18V$
Spike Blanking Time before Auto-Restart Protection	$t_{Spike}$	-	30	-	$\mu$ s	

<sup>1)</sup> The parameter is not subjected to production test - verified by design/characterization. The thermal shutdown temperature refers to the junction temperature of the controller.

*Note:* The trend of all the voltage levels in the Control Unit is the same regarding the deviation except  $V_{VCCOVP}$ .

**Electrical Characteristics**
**4.3.6 Current Limiting**

Parameter	Symbol	Limit Values			Unit	Test Condition
		min.	typ.	max.		
Peak Current Limitation (incl. Propagation Delay)	$V_{\text{csth}}$	0.95	1.03	1.10	V	$dV_{\text{sense}}/dt = 0.6\text{V}/\mu\text{s}$ (see Figure 20)
Peak Current Limitation during Active Burst Mode	$V_{\text{CS2}}$	0.29	0.34	0.38	V	
Leading Edge Blanking	$t_{\text{LEB}}$	-	220	-	ns	
CS Input Bias Current	$I_{\text{CSbias}}$	-1.6	-0.2	-	$\mu\text{A}$	$V_{\text{CS}} = 0\text{V}$

**4.3.7 CoolMOS® Section**

Parameter	Symbol	Limit Values			Unit	Test Condition
		min.	typ.	max.		
Drain Source Breakdown Voltage	$V_{(\text{BR})\text{DSS}}$	650	-	-	V	$T_j = 110^\circ\text{C}$ , Refer to Figure 30 for other $V_{(\text{BR})\text{DSS}}$ in different $T_j$
Drain Source On-Resistance	$R_{\text{DSon}}$	-	1.70 3.57	1.96 4.12	$\Omega$ $\Omega$	$T_j = 25^\circ\text{C}$ $T_j = 125^\circ\text{C}^{1)}$ at $I_D = 1.5\text{A}$
Effective output capacitance, energy related	$C_{\text{o(er)}}$	-	11.63	-	pF	$V_{\text{DS}} = 0\text{V to } 480\text{V}^{1)}$
Rise Time	$t_{\text{rise}}$	-	30 <sup>2)</sup>	-	ns	
Fall Time	$t_{\text{fall}}$	-	30 <sup>2)</sup>	-	ns	

<sup>1)</sup> The parameter is not subjected to production test - verified by design/characterization

<sup>2)</sup> Measured in a Typical Flyback Converter Application

Typical CoolMOS® Performance Characteristic

# 5 Typical CoolMOS® Performance Characteristic

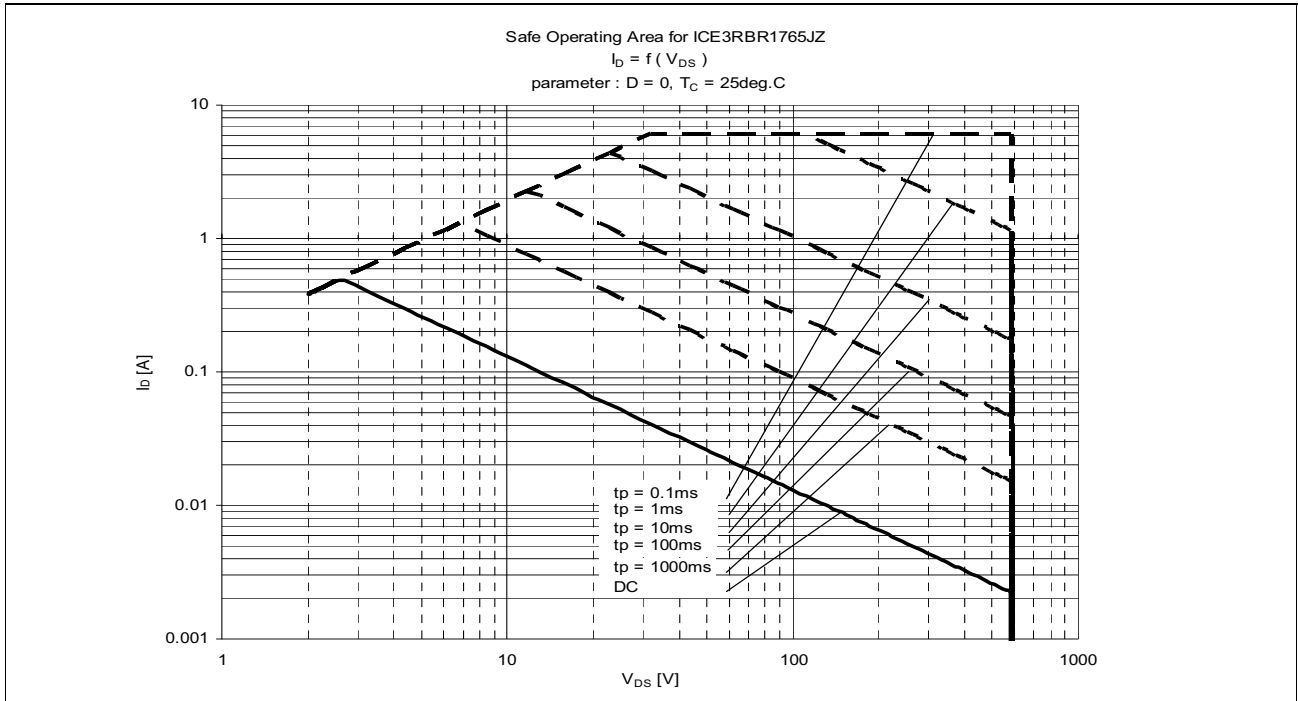


Figure 27 Safe Operating area (SOA) curve for ICE3RBR1765JZ

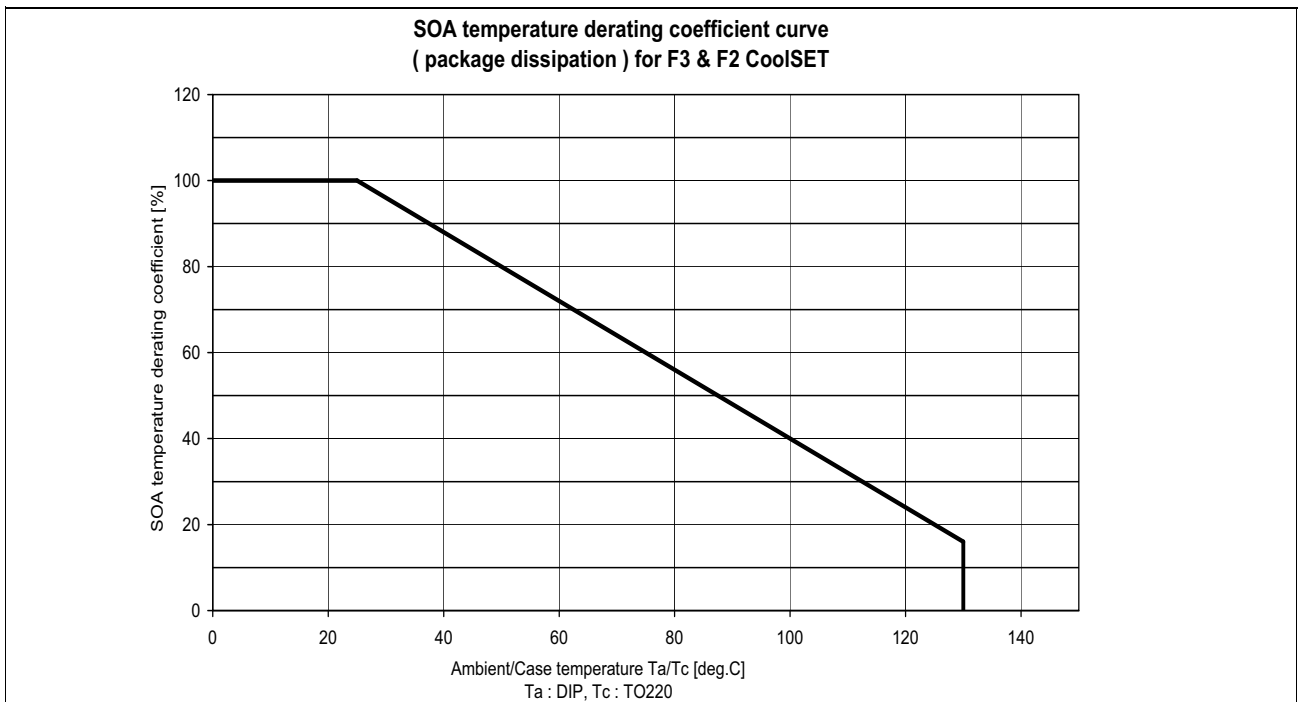


Figure 28 SOA temperature derating coefficient curve

Typical CoolMOS® Performance Characteristic

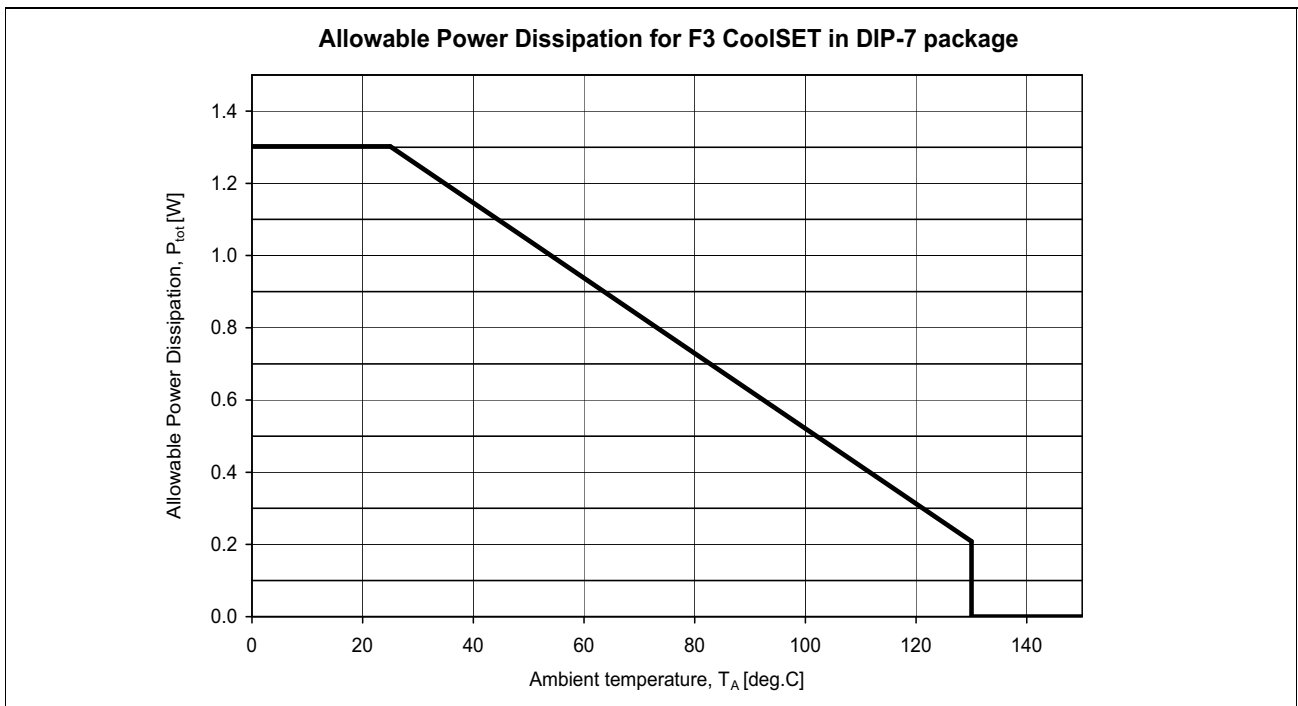


Figure 29 Power dissipation;  $P_{tot}=f(T_a)$

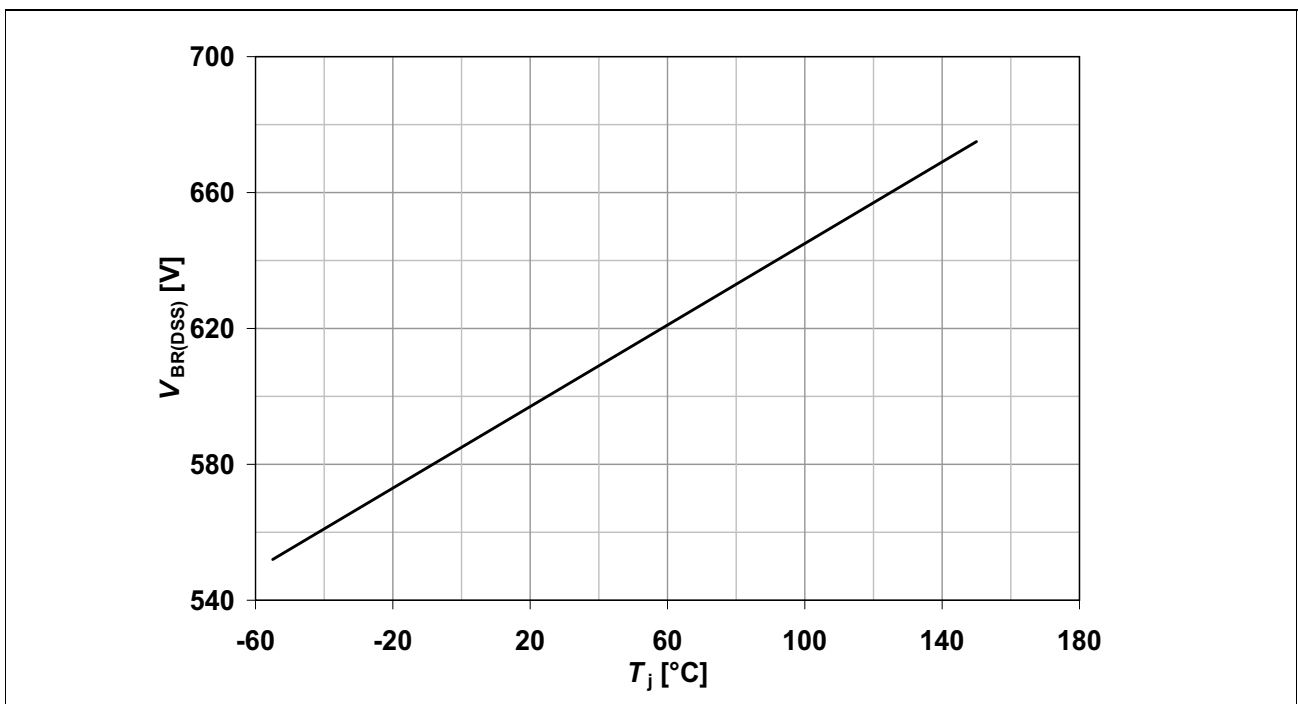


Figure 30 Drain-source breakdown voltage;  $V_{BR(DSS)}=f(T_j)$ ,  $I_D=0.25mA$