



Chipsmall Limited consists of a professional team with an average of over 10 year of expertise in the distribution of electronic components. Based in Hongkong, we have already established firm and mutual-benefit business relationships with customers from,Europe,America and south Asia,supplying obsolete and hard-to-find components to meet their specific needs.

With the principle of "Quality Parts,Customers Priority,Honest Operation,and Considerate Service",our business mainly focus on the distribution of electronic components. Line cards we deal with include Microchip,ALPS,ROHM,Xilinx,Pulse,ON,Everlight and Freescale. Main products comprise IC,Modules,Potentiometer,IC Socket,Relay,Connector.Our parts cover such applications as commercial,industrial, and automotives areas.

We are looking forward to setting up business relationship with you and hope to provide you with the best service and solution. Let us make a better world for our industry!



Contact us

Tel: +86-755-8981 8866 Fax: +86-755-8427 6832

Email & Skype: info@chipsmall.com Web: www.chipsmall.com

Address: A1208, Overseas Decoration Building, #122 Zhenhua RD., Futian, Shenzhen, China



1 Microamp, +3V to +5.5V, 250kbps, RS-232 Transceivers with Enhanced Automatic Powerdown

The Intersil ICL32XX devices are 3.0V to 5.5V powered RS-232 transmitters/receivers which meet EIA/TIA-232 and V.28/V.24 specifications, even at $V_{CC} = 3.0V$. Targeted applications are PDAs, Palmtops, and notebook and laptop computers where the low operational, and even lower standby, power consumption is critical. Efficient on-chip charge pumps, coupled with manual and enhanced automatic powerdown functions, reduce the standby supply current to a 1 μ A trickle. Small footprint packaging, and the use of small, low value capacitors ensure board space savings as well. Data rates greater than 250kbps are guaranteed at worst case load conditions. This family is fully compatible with 3.3V only systems, mixed 3.3V and 5.0V systems, and 5.0V only systems.

The ICL3244 is a 3 driver, 5 receiver device that provides a complete serial port suitable for laptop or notebook computers. The ICL3244/38 also include a noninverting always-active receiver for RING INDICATOR monitoring.

These devices feature an **enhanced automatic powerdown** function which powers down the on-chip power-supply and driver circuits. This occurs when all receiver and transmitter inputs detect no signal transitions for a period of 30sec. These devices power back up, automatically, whenever they sense a transition on any transmitter or receiver input.

Table 1 summarizes the features of the devices represented by this data sheet, while Application Note AN9863 summarizes the features of each device comprising the ICL32XX 3V family.

Features

- Pb-Free Plus Anneal Available (RoHS Compliant)
- $\pm 15kV$ ESD Protected (Human Body Model)
- Manual and Enhanced Automatic Powerdown Features
- Drop in Replacements for MAX3224, MAX3226, MAX3238, MAX3244
- Meets EIA/TIA-232 and V.28/V.24 Specifications at 3V
- Latch-Up Free
- RS-232 Compatible with $V_{CC} = 2.7V$
- On-Chip Voltage Converters Require Only Four External 0.1 μ F Capacitors
- Flow-Through Pinout (ICL3238)
- Guaranteed Mouse Driveability (ICL3244)
- "Ready to Transmit" Indicator Output (ICL3224/26)
- Receiver Hysteresis For Improved Noise Immunity
- Guaranteed Minimum Data Rate 250kbps
- Guaranteed Minimum Slew Rate 6V/ μ s
- Wide Power Supply Range Single +3V to +5.5V
- Low Supply Current in Powerdown State. 1 μ A

Applications

- Any System Requiring RS-232 Communication Ports
 - Battery Powered, Hand-Held, and Portable Equipment
 - Laptop Computers, Notebooks, Palmtops
 - Modems, Printers and other Peripherals
 - Digital Cameras
 - Cellular/Mobile Phones
 - Data Cradles

Related Literature

- Technical Brief TB363 "Guidelines for Handling and Processing Moisture Sensitive Surface Mount Devices (SMDs)"
- AN9863, "3V to +5.5V, 250k-1Mbps, RS-232 Transmitters/Receivers"

TABLE 1. SUMMARY OF FEATURES

PART NUMBER	NO. OF Tx.	NO. OF Rx.	NO. OF MONITOR Rx. (R _{OUTB})	DATA RATE (kbps)	Rx. ENABLE FUNCTION?	READY OUTPUT?	MANUAL POWER-DOWN?	ENHANCED AUTOMATIC POWERDOWN
ICL3224	2	2	0	250	NO	YES	YES	YES
ICL3226	1	1	0	250	NO	YES	YES	YES
ICL3238	5	3	1	250	NO	NO	YES	YES
ICL3244	3	5	1	250	NO	NO	YES	YES

Ordering Information

PART NUMBER*	PART MARKING	TEMP. RANGE (°C)	PACKAGE	PKG. DWG. #
ICL3224CA	ICL3224CA	0 to 70	20 Ld SSOP	M20.209
ICL3224CAZ (Note)	3224CAZ	0 to 70	20 Ld SSOP (Pb-free)	M20.209
ICL3224IA	ICL3224IA	-40 to 85	20 Ld SSOP	M20.209
ICL3224IAZ (Note)	3224IAZ	-40 to 85	20 Ld SSOP (Pb-free)	M20.209
ICL3226CA	ICL3226CA	0 to 70	16 Ld SSOP	M16.209
ICL3226CAZ (Note)	ICL3226CAZ	0 to 70	16 Ld SSOP (Pb-free)	M16.209
ICL3226IA	ICL3226IA	-40 to 85	16 Ld SSOP	M16.209
ICL3226IAZ (Note)	ICL3226IAZ	-40 to 85	16 Ld SSOP (Pb-free)	M16.209
ICL3238CA	ICL3238CA	0 to 70	28 Ld SSOP	M28.209

Ordering Information (Continued)

PART NUMBER*	PART MARKING	TEMP. RANGE (°C)	PACKAGE	PKG. DWG. #
ICL3238CAZ (Note)	ICL3238CAZ	0 to 70	28 Ld SSOP (Pb-free)	M28.209
ICL3238IA	ICL3238IA	-40 to 85	28 Ld SSOP	M28.209
ICL3238IAZ (Note)	ICL3238IAZ	-40 to 85	28 Ld SSOP (Pb-free)	M28.209
ICL3244CA	ICL3244CA	0 to 70	28 Ld SSOP	M28.209
ICL3244IA	ICL3244IA	-40 to 85	28 Ld SSOP	M28.209

* Most surface mount devices are available on tape and reel; add "-T" to suffix.

NOTE: Intersil Pb-free plus anneal products employ special Pb-free material sets; molding compounds/die attach materials and 100% matte tin plate termination finish, which are RoHS compliant and compatible with both SnPb and Pb-free soldering operations. Intersil Pb-free products are MSL classified at Pb-free peak reflow temperatures that meet or exceed the Pb-free requirements of IPC/JEDEC J STD-020.

Pinouts

ICL3224 (SSOP)
TOP VIEW

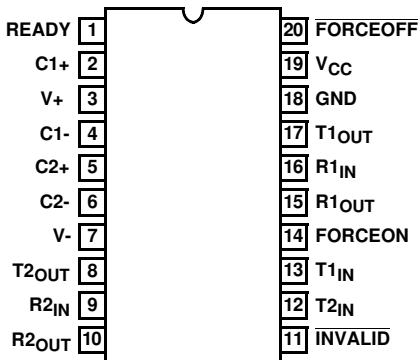

ICL3226 (SSOP)
TOP VIEW

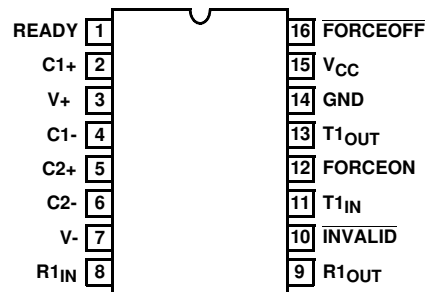

Pinouts (Continued)

ICL3238 (SSOP)
TOP VIEW

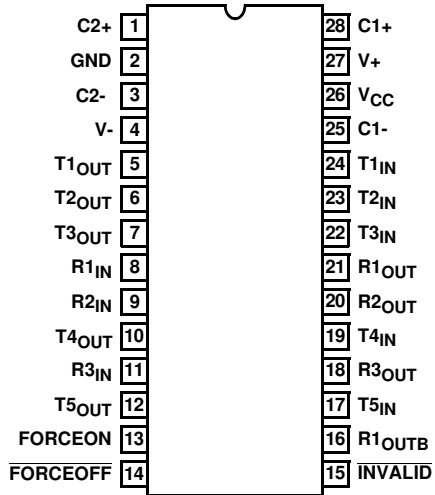

ICL3244 (SSOP)
TOP VIEW

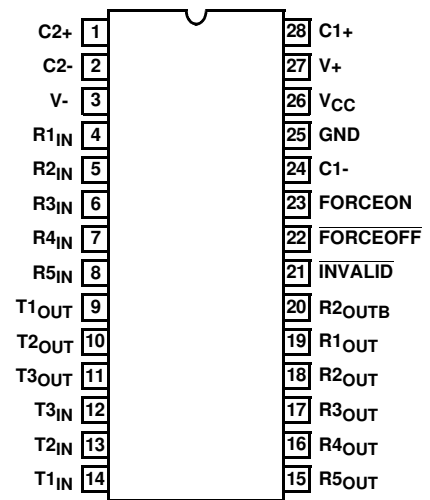

Pin Descriptions

PIN	FUNCTION
V _{CC}	System power supply input (3.0V to 5.5V).
V+	Internally generated positive transmitter supply (+5.5V).
V-	Internally generated negative transmitter supply (-5.5V).
GND	Ground connection.
C1+	External capacitor (voltage doubler) is connected to this lead.
C1-	External capacitor (voltage doubler) is connected to this lead.
C2+	External capacitor (voltage inverter) is connected to this lead.
C2-	External capacitor (voltage inverter) is connected to this lead.
T _{IN}	TTL/CMOS compatible transmitter Inputs.
T _{OUT}	RS-232 level (nominally ±5.5V) transmitter outputs.
R _{IN}	RS-232 compatible receiver inputs.
R _{OUT}	TTL/CMOS level receiver outputs.
R _{OUTB}	TTL/CMOS level, noninverting, always enabled receiver outputs.
$\overline{\text{INVALID}}$	Active low output that indicates if no valid RS-232 levels are present on any receiver input.
READY	Active high output that indicates when the ICL32XX is ready to transmit (i.e., V ₋ ≤ -4V)
FORCEOFF	Active low to shut down transmitters and on-chip power supply. This overrides any automatic circuitry and FORCEON (see Table 2).
FORCEON	Active high input to override automatic powerdown circuitry thereby keeping transmitters active. ($\overline{\text{FORCEOFF}}$ must be high).

Typical Operating Circuits

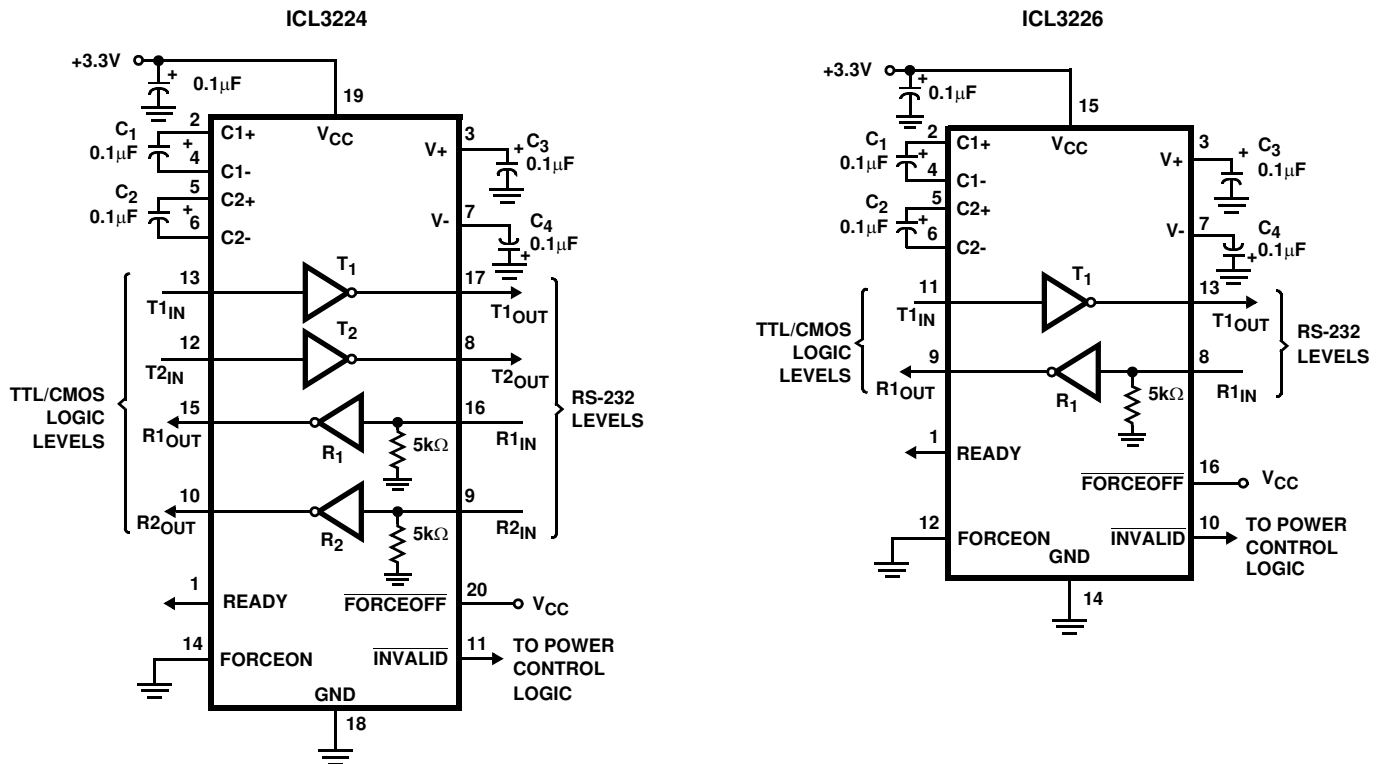

Typical Operating Circuits (Continued)

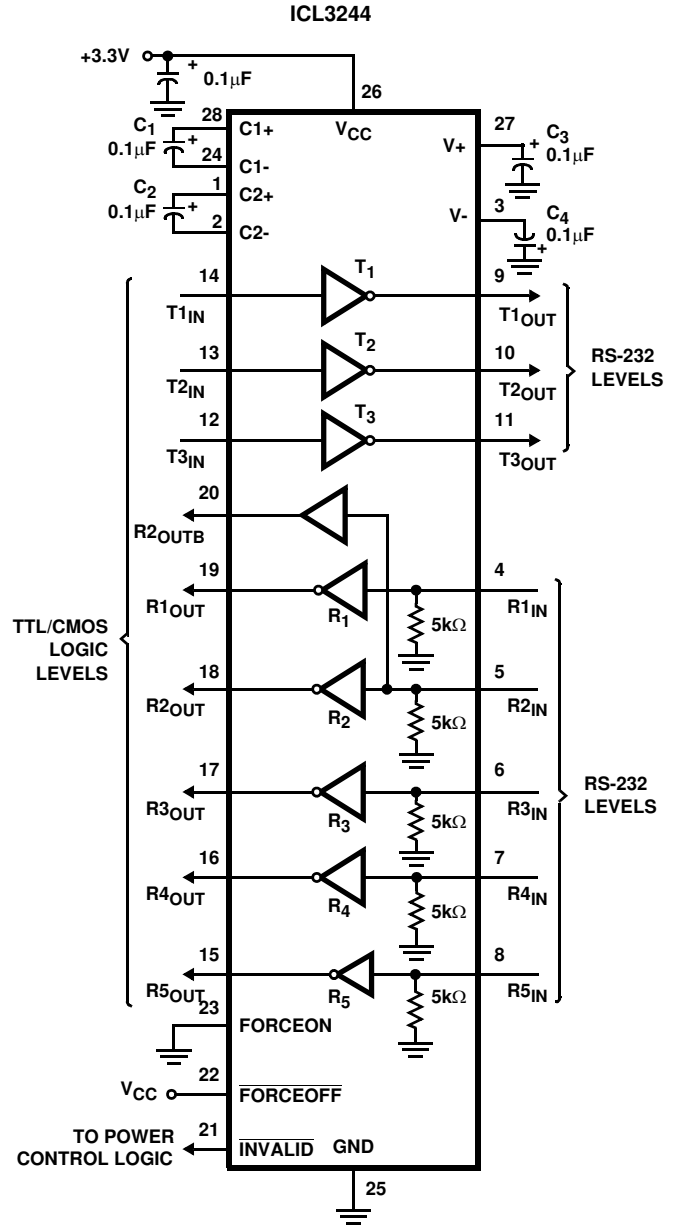
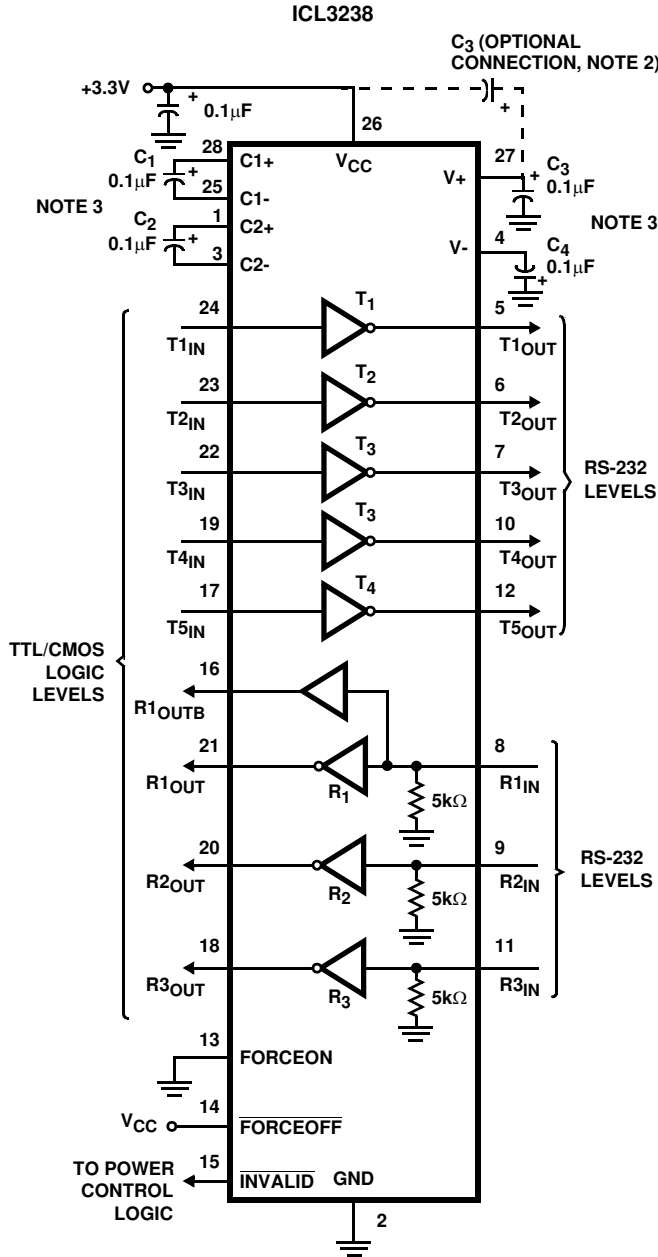

NOTES:

1. THE NEGATIVE TERMINAL OF C₃ CAN BE CONNECTED TO EITHER V_{CC} OR GND.
2. FOR V_{CC} = 3.15V (3.3V -5%), USE C₁ - C₄ = 0.1µF OR GREATER. FOR V_{CC} = 3.0V (3.3V -10%), USE C₁ - C₄ = 0.22µF.

ICL3224, ICL3226, ICL3238, ICL3244

Absolute Maximum Ratings

V _{CC} to Ground	-0.3V to 6V
V ₊ to Ground	-0.3V to 7V
V ₋ to Ground	+0.3V to -7V
V ₊ to V ₋	14V
Input Voltages	
T _{IN} , FORCEOFF, FORCEON	-0.3V to 6V
R _{IN}	±25V
Output Voltages	
T _{OUT}	±13.2V
R _{OUT} , INVALID, READY	-0.3V to V _{CC} +0.3V
Short Circuit Duration	
T _{OUT}	Continuous
ESD Rating	See Specification Table

Thermal Information

Thermal Resistance (Typical, Note 4)	θ _{JA} (°C/W)
16 Ld SSOP Package	140
20 Ld SSOP Package	125
28 Ld SSOP Package	100
Maximum Junction Temperature (Plastic Package)	150°C
Maximum Storage Temperature Range	-65°C to 150°C
Maximum Lead Temperature (Soldering 10s) (Lead Tips Only)	300°C

Operating Conditions

Temperature Range	
ICL32XXC	0°C to 70°C
ICL32XXI	-40°C to 85°C

CAUTION: Stresses above those listed in "Absolute Maximum Ratings" may cause permanent damage to the device. This is a stress only rating and operation of the device at these or any other conditions above those indicated in the operational sections of this specification is not implied.

NOTE:

- θ_{JA} is measured with the component mounted on a low effective thermal conductivity test board in free air. See Tech Brief TB379 for details.

Electrical Specifications Test Conditions: V_{CC} = 3V to 5.5V, C₁ - C₄ = 0.1μF (ICL3238: C₁ - C₄ = 0.22μF @ V_{CC} = 3V); Unless Otherwise Specified. Typical values are at T_A = 25°C

PARAMETER	TEST CONDITIONS	TEMP (°C)	MIN	TYP	MAX	UNITS	
DC CHARACTERISTICS							
Supply Current, Automatic Powerdown	All R _{IN} Open, FORCEON = GND, FORCEOFF = V _{CC}	25	-	1.0	10	μA	
Supply Current, Powerdown	FORCEOFF = GND	25	-	1.0	10	μA	
Supply Current, Automatic Powerdown Disabled	All Outputs Unloaded, FORCEON = FORCEOFF = V _{CC}	ICL3244, V _{CC} = 3V	25	-	0.3	1.0	mA
		All Others, V _{CC} = 3.15V	25	-	0.3	1.0	mA
LOGIC AND TRANSMITTER INPUTS AND RECEIVER OUTPUTS							
Input Logic Threshold Low	T _{IN} , FORCEON, FORCEOFF	Full	-	-	0.8	V	
Input Logic Threshold High	T _{IN} , FORCEON, FORCEOFF	V _{CC} = 3.3V	Full	2.0	-	-	V
		V _{CC} = 5.0V	Full	2.4	-	-	V
Transmitter Input Hysteresis		25	-	0.5	-	V	
Input Leakage Current	T _{IN} , FORCEON, FORCEOFF	Full	-	±0.01	±1.0	μA	
Output Leakage Current	FORCEOFF = GND	Full	-	±0.05	±10	μA	
Output Voltage Low	I _{OUT} = 1.6mA	Full	-	-	0.4	V	
Output Voltage High	I _{OUT} = -1.0mA	Full	V _{CC} -0.6	V _{CC} -0.1	-	V	
RECEIVER INPUTS							
Input Voltage Range		Full	-25	-	25	V	
Input Threshold Low	V _{CC} = 3.3V	25	0.6	1.2	-	V	
	V _{CC} = 5.0V	25	0.8	1.5	-	V	
Input Threshold High	V _{CC} = 3.3V	25	-	1.5	2.4	V	
	V _{CC} = 5.0V	25	-	1.8	2.4	V	
Input Hysteresis		25	-	0.5	-	V	
Input Resistance		25	3	5	7	kΩ	
TRANSMITTER OUTPUTS							
Output Voltage Swing	All Transmitter Outputs Loaded with 3kΩ to Ground	Full	±5.0	±5.4	-	V	
Output Resistance	V _{CC} = V ₊ = V ₋ = 0V, Transmitter Output = ±2V	Full	300	10M	-	Ω	
Output Short-Circuit Current		Full	-	±35	±60	mA	
Output Leakage Current	V _{OUT} = ±12V, V _{CC} = 0V or 3V to 5.5V, Automatic Powerdown or FORCEOFF = GND	Full	-	-	±25	μA	

ICL3224, ICL3226, ICL3238, ICL3244

Electrical Specifications Test Conditions: $V_{CC} = 3V$ to $5.5V$, $C_1 - C_4 = 0.1\mu F$ (ICL3238: $C_1 - C_4 = 0.22\mu F @ V_{CC} = 3V$); Unless Otherwise Specified. Typicals are at $T_A = 25^\circ C$ **(Continued)**

PARAMETER	TEST CONDITIONS	TEMP (°C)	MIN	TYP	MAX	UNITS	
MOUSE DRIVEABILITY (ICL3244 Only)							
Transmitter Output Voltage (See Figure 11)	$T1_{IN} = T2_{IN} = GND$, $T3_{IN} = V_{CC}$, $T3_{OUT}$ Loaded with $3k\Omega$ to GND , $T1_{OUT}$ and $T2_{OUT}$ Loaded with $2.5mA$ Each	Full	± 5	-	-	V	
ENHANCED AUTOMATIC POWERDOWN (FORCEON = GND, FORCEOFF = V_{CC})							
Receiver Input Thresholds to $\overline{INVALID}$ High	See Figure 6	Full	-2.7	-	2.7	V	
Receiver Input Thresholds to $\overline{INVALID}$ Low	See Figure 6	Full	-0.3	-	0.3	V	
$\overline{INVALID}$, READY Output Voltage Low	$I_{OUT} = 1.6mA$	Full	-	-	0.4	V	
$\overline{INVALID}$, READY Output Voltage High	$I_{OUT} = -1.0mA$	Full	$V_{CC}-0.6$	-	-	V	
Receiver Positive or Negative Threshold to $\overline{INVALID}$ High Delay (t_{INVH})	ICL3238	25	-	0.1	-	μs	
	All Others	25	-	1	-	μs	
Receiver Positive or Negative Threshold to $\overline{INVALID}$ Low Delay (t_{INVL})	ICL3238	25	-	50	-	μs	
	All Others	25	-	30	-	μs	
Receiver or Transmitter Edge to Transmitters Enabled Delay (t_{WU})	ICL3238, Note 5	25	-	25	-	μs	
	All Others, Note 5	25	-	100	-	μs	
Receiver or Transmitter Edge to Transmitters Disabled Delay ($t_{AUTOPWDN}$)	Note 5	Full	15	30	60	sec	
TIMING CHARACTERISTICS							
Maximum Data Rate	$R_L = 3k\Omega$, $C_L = 1000pF$, One Transmitter Switching	Full	250	500	-	kbps	
Receiver Propagation Delay	Receiver Input to Receiver Output, $C_L = 150pF$	t_{PHL}	25	-	0.15	μs	
		t_{PLH}	25	-	0.15	μs	
Receiver Output Enable Time	Normal Operation (ICL3238/44 Only)	25	-	200	-	ns	
Receiver Output Disable Time	Normal Operation (ICL3238/44 Only)	25	-	200	-	ns	
Transmitter Skew	$t_{PHL} - t_{PLH}$	25	-	100	-	ns	
Receiver Skew	$t_{PHL} - t_{PLH}$	25	-	50	-	ns	
Transition Region Slew Rate	$V_{CC} = 3.3V$, $R_L = 3k\Omega$ to $7k\Omega$, Measured From $3V$ to $-3V$ or $-3V$ to $3V$	$C_L = 150pF$ to $1000pF$	25	6	-	30	$V/\mu s$
		$C_L = 150pF$ to $2500pF$	25	4	8	30	$V/\mu s$
ESD PERFORMANCE							
RS-232 Pins (T_{OUT} , R_{IN})	Human Body Model	25	-	± 15	-	kV	
	IEC61000-4-2 Contact Discharge	25	-	± 8	-	kV	
	IEC61000-4-2 Air Gap Discharge	25	-	± 10	-	kV	
All Other Pins	Human Body Model	25	-	± 2.5	-	kV	

NOTE:

- An "edge" is defined as a transition through the transmitter or receiver input thresholds.

Detailed Description

These ICL32XX interface ICs operate from a single +3V to +5.5V supply, guarantee a 250kbps minimum data rate, require only four small external 0.1µF capacitors, feature low power consumption, and meet all EIA RS-232C and V.28 specifications. The circuit is divided into three sections: The charge pump, the transmitters, and the receivers.

Charge-Pump

Intersil's new ICL32XX family utilizes regulated on-chip dual charge pumps as voltage doublers, and voltage inverters to generate ±5.5V transmitter supplies from a V_{CC} supply as low as 3.0V. This allows these devices to maintain RS-232 compliant output levels over the ±10% tolerance range of 3.3V powered systems. The efficient on-chip power supplies require only four small, external 0.1µF capacitors for the voltage doubler and inverter functions at V_{CC} = 3.3V. See the "Capacitor Selection" section, and Table 3 for capacitor recommendations for other operating conditions. The charge pumps operate discontinuously (i.e., they turn off as soon as the V+ and V- supplies are pumped up to the nominal values), resulting in significant power savings.

Transmitters

The transmitters are proprietary, low dropout, inverting drivers that translate TTL/CMOS inputs to EIA/TIA-232 output levels. Coupled with the on-chip ±5.5V supplies, these transmitters deliver true RS-232 levels over a wide range of single supply system voltages.

Transmitter outputs disable and assume a high impedance state when the device enters the powerdown mode (see Table 2). These outputs may be driven to ±12V when disabled.

All devices guarantee a 250kbps data rate for full load conditions (3kΩ and 1000pF), V_{CC} ≥ 3.0V, with one transmitter operating at full speed. Under more typical conditions of V_{CC} ≥ 3.3V, R_L = 3kΩ, and C_L = 250pF, one transmitter easily operates at 1Mbps.

Transmitter inputs float if left unconnected, and may cause I_{CC} increases. Connect unused inputs to GND for the best performance.

Receivers

All the ICL32XX devices contain standard inverting receivers, but only the ICL3238 and ICL3244 receivers can tristate, via the FORCEOFF control line. Additionally, the ICL3238 and ICL3244 include a noninverting (monitor) receiver (denoted by the R_{OUTB} label) that is always active, regardless of the state of any control lines. Both receiver types convert RS-232 signals to CMOS output levels and accept inputs up to ±25V while presenting the required 3kΩ to 7kΩ input impedance (see Figure 1) even if the power is off (V_{CC} = 0V). The receivers' Schmitt trigger input stage uses hysteresis to increase noise immunity and decrease errors due to slow input signal transitions.

The ICL3238 and ICL3244 inverting receivers disable during forced (manual) powerdown, but not during automatic powerdown (see Table 2). Conversely, the monitor receiver remains active even during manual powerdown making it extremely useful for Ring Indicator monitoring. Standard receivers driving powered down peripherals must be disabled to prevent current flow through the peripheral's protection diodes (see Figures 2 and 3). This renders them useless for wake up functions, but the corresponding monitor receiver can be dedicated to this task as shown in Figure 3.

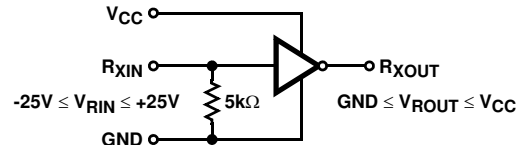

FIGURE 1. INVERTING RECEIVER CONNECTIONS

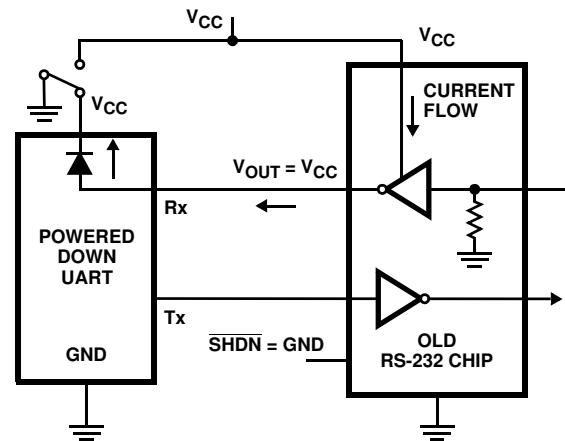

FIGURE 2. POWER DRAIN THROUGH POWERED DOWN PERIPHERAL

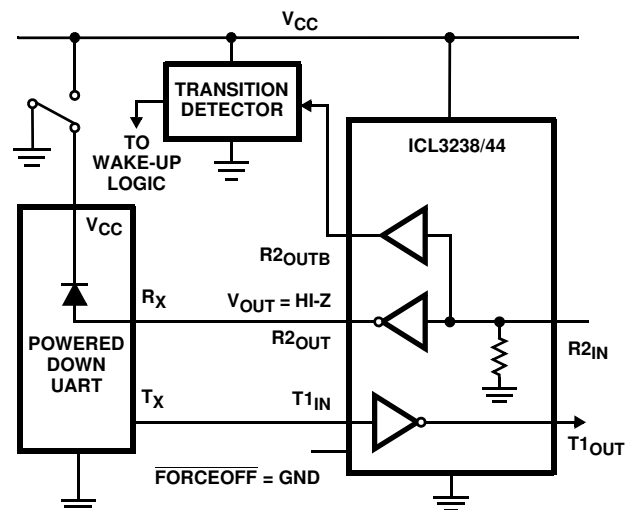

FIGURE 3. DISABLED RECEIVERS PREVENT POWER DRAIN

TABLE 2. POWERDOWN LOGIC TRUTH TABLE

RCVR OR XMTR EDGE WITHIN 30 SEC?	FORCEOFF INPUT	FORCEON INPUT	TRANSMITTER OUTPUTS	RECEIVER OUTPUTS	(NOTE 6) ROUTB OUTPUTS	RS-232 LEVEL PRESENT AT RECEIVER INPUT?	INVALID OUTPUT	MODE OF OPERATION
ICL3224, ICL3226								
NO	H	H	Active	Active	N.A.	NO	L	Normal Operation (Enhanced Auto Powerdown Disabled)
NO	H	H	Active	Active	N.A.	YES	H	
YES	H	L	Active	Active	N.A.	NO	L	Normal Operation (Enhanced Auto Powerdown Enabled)
YES	H	L	Active	Active	N.A.	YES	H	
NO	H	L	High-Z	Active	N.A.	NO	L	Powerdown Due to Enhanced Auto Powerdown Logic
NO	H	L	High-Z	Active	N.A.	YES	H	
X	L	X	High-Z	Active	N.A.	NO	L	Manual Powerdown
X	L	X	High-Z	Active	N.A.	YES	H	
ICL322X - INVALID DRIVING FORCEON AND FORCEOFF (EMULATES AUTOMATIC POWERDOWN)								
X	NOTE 7	NOTE 7	Active	Active	N.A.	YES	H	Normal Operation
X	NOTE 7	NOTE 7	High-Z	Active	N.A.	NO	L	Forced Auto Powerdown
ICL3238, ICL3244								
NO	H	H	Active	Active	Active	NO	L	Normal Operation (Enhanced Auto Powerdown Disabled)
NO	H	H	Active	Active	Active	YES	H	
YES	H	L	Active	Active	Active	NO	L	Normal Operation (Enhanced Auto Powerdown Enabled)
YES	H	L	Active	Active	Active	YES	H	
NO	H	L	High-Z	Active	Active	NO	L	Powerdown Due to Enhanced Auto Powerdown Logic
NO	H	L	High-Z	Active	Active	YES	H	
X	L	X	High-Z	High-Z	Active	NO	L	Manual Powerdown
X	L	X	High-Z	High-Z	Active	YES	H	
ICL3238, ICL3244 - INVALID DRIVING FORCEON AND FORCEOFF (EMULATES AUTOMATIC POWERDOWN)								
X	NOTE 7	NOTE 7	Active	Active	Active	YES	H	Normal Operation
X	NOTE 7	NOTE 7	High-Z	High-Z	Active	NO	L	Forced Auto Powerdown

NOTES:

- 5. Applies only to the ICL3238 and ICL3244.
- 6. Input is connected to $\overline{\text{INVALID}}$ Output.

Powerdown Functionality

This 3V family of RS-232 interface devices requires a nominal supply current of 0.3mA during normal operation (not in powerdown mode). This is considerably less than the 5mA to 11mA current required of 5V RS-232 devices. The already low current requirement drops significantly when the device enters powerdown mode. In powerdown, supply current drops to 1µA, because the on-chip charge pump turns off (V+ collapses to V_{CC}, V- collapses to GND), and the transmitter outputs tristate. Inverting receiver outputs may or may not disable in powerdown; refer to Table 2 for details. This micro-power mode makes these devices ideal for battery powered and portable applications.

Software Controlled (Manual) Powerdown

These devices allow the user to force the IC into the low power, standby state, and utilize a two pin approach where

the FORCEON and $\overline{\text{FORCEOFF}}$ inputs determine the IC's mode. For always enabled operation, FORCEON and $\overline{\text{FORCEOFF}}$ are both strapped high. To switch between active and powerdown modes, under logic or software control, only the $\overline{\text{FORCEOFF}}$ input need be driven. The FORCEON state isn't critical, as $\overline{\text{FORCEOFF}}$ dominates over FORCEON. Nevertheless, if strictly manual control over powerdown is desired, the user must strap FORCEON high to disable the enhanced automatic powerdown circuitry. ICL3238 and ICL3244 inverting (standard) receiver outputs also disable when the device is in powerdown, thereby eliminating the possible current path through a shutdown peripheral's input protection diode (see Figures 2 and 3).

Connecting $\overline{\text{FORCEOFF}}$ and FORCEON together disables the enhanced automatic powerdown feature, enabling them to function as a manual SHUTDOWN input (see Figure 4).

With any of the above control schemes, the time required to exit powerdown, and resume transmission is only 100µs.

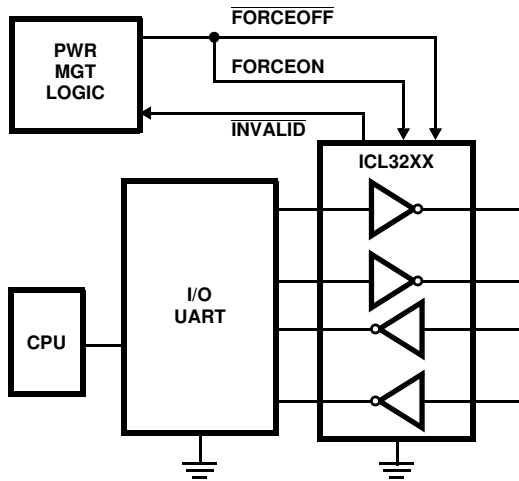

FIGURE 4. CONNECTIONS FOR MANUAL POWERDOWN WHEN NO VALID RECEIVER SIGNALS ARE PRESENT

When using both manual and enhanced automatic powerdown ($FORCEON = 0$), the ICL32XX won't power up from manual powerdown until both $FORCEOFF$ and $FORCEON$ are driven high, or until a transition occurs on a receiver or transmitter input. Figure 5 illustrates a circuit for ensuring that the ICL32XX powers up as soon as $FORCEOFF$ switches high. The rising edge of the Master Powerdown signal forces the device to power up, and the ICL32XX returns to enhanced automatic powerdown mode an RC time constant after this rising edge. The time constant isn't critical, because the ICL32XX remains powered up for 30 seconds after the $FORCEON$ falling edge, even if there are no signal transitions. This gives slow-to-wake systems (e.g., a mouse) plenty of time to start transmitting, and as long as it starts transmitting within 30 seconds both systems remain enabled.

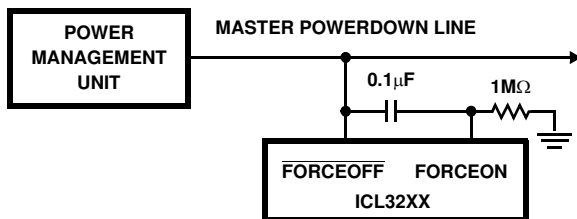

FIGURE 5. CIRCUIT TO ENSURE IMMEDIATE POWER UP WHEN EXITING FORCED POWERDOWN

INVALID Output

The $\overline{INVALID}$ output always indicates (see Table 2) whether or not 30µs have elapsed with invalid RS-232 signals (see Figures 6 and 8) persisting on all of the receiver inputs, giving the user an easy way to determine when the interface block should power down. Invalid receiver levels occur whenever the driving peripheral's outputs are shut off (powered down) or when the RS-232 interface cable is disconnected. In the case of a disconnected interface cable where all the receiver inputs

are floating (but pulled to GND by the internal receiver pull down resistors), the $\overline{INVALID}$ logic detects the invalid levels and drives the output low. The power management logic then uses this indicator to power down the interface block. Reconnecting the cable restores valid levels at the receiver inputs, $\overline{INVALID}$ switches high, and the power management logic wakes up the interface block. $\overline{INVALID}$ can also be used to indicate the DTR or RING INDICATOR signal, as long as the other receiver inputs are floating, or driven to GND (as in the case of a powered down driver).

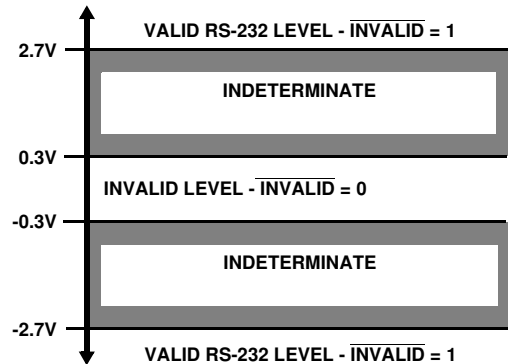

FIGURE 6. DEFINITION OF VALID RS-232 RECEIVER LEVELS

Enhanced Automatic Powerdown

Even greater power savings is available by using these devices which feature an *enhanced automatic* powerdown function. When the enhanced powerdown logic determines that no transitions have occurred on any of the transmitter nor receiver inputs for 30 seconds, the charge pump and transmitters powerdown, thereby reducing supply current to 1µA. The ICL32XX automatically powers back up whenever it detects a transition on one of these inputs. This automatic powerdown feature provides additional system power savings without changes to the existing operating system.

Enhanced automatic powerdown operates when the $FORCEON$ input is low, and the $FORCEOFF$ input is high. Tying $FORCEON$ high disables automatic powerdown, but manual powerdown is always available via the overriding $FORCEOFF$ input. Table 2 summarizes the enhanced automatic powerdown functionality.

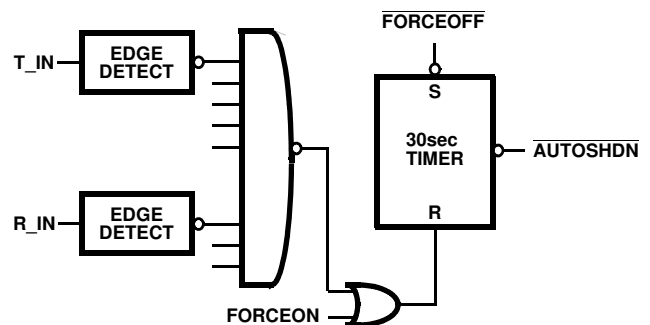

FIGURE 7. ENHANCED AUTOMATIC POWERDOWN LOGIC

Figure 7 illustrates the enhanced powerdown control logic. Note that once the ICL32XX enters powerdown (manually or automatically), the 30 second timer remains timed out (set), keeping the ICL32XX powered down until FORCEON transitions high, or until a transition occurs on a receiver or transmitter input.

The $\overline{\text{INVALID}}$ output signal switches low to indicate that invalid levels have persisted on all of the receiver inputs for more than 30 μs (see Figure 8), but this has no direct effect on the state of the ICL32XX (see the next sections for methods of utilizing $\overline{\text{INVALID}}$ to power down the device). $\overline{\text{INVALID}}$ switches high 1 μs after detecting a valid RS-232 level on a receiver input. $\overline{\text{INVALID}}$ operates in all modes (forced or automatic powerdown, or forced on), so it is also useful for systems employing manual powerdown circuitry.

The time to recover from automatic powerdown mode is typically 100 μs .

Emulating Standard Automatic Powerdown

If enhanced automatic powerdown isn't desired, the user can implement the standard automatic powerdown feature (mimics the function on the ICL3221/23/43) by connecting the $\overline{\text{INVALID}}$ output to the FORCEON and $\overline{\text{FORCEOFF}}$ inputs, as shown in Figure 9. After 30 μs of invalid receiver levels, $\overline{\text{INVALID}}$ switches low and drives the ICL32XX into a forced powerdown condition. $\overline{\text{INVALID}}$ switches high as soon as a receiver input senses a valid RS-232 level, forcing the ICL32XX to power on. See the "INVALID DRIVING FORCEON AND $\overline{\text{FORCEOFF}}$ " section of Table 2 for an operational summary. This operational mode is perfect for handheld devices that communicate with another computer via a detachable cable. Detaching the cable allows the internal receiver pull-down resistors to pull the inputs to GND

(an invalid RS-232 level), causing the 30 μs timer to time-out and drive the IC into powerdown. Reconnecting the cable restores valid levels, causing the IC to power back up.

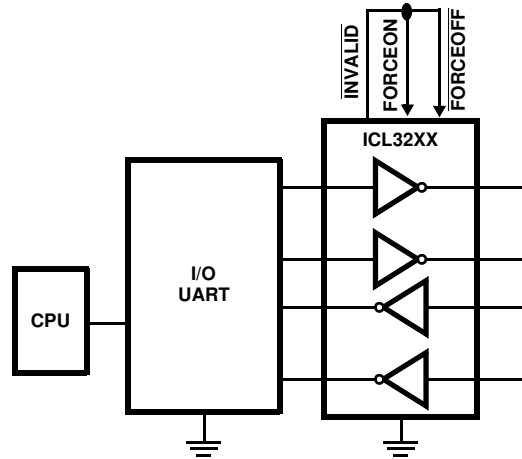

FIGURE 9. CONNECTIONS FOR AUTOMATIC POWERDOWN WHEN NO VALID RECEIVER SIGNALS ARE PRESENT

Hybrid Automatic Powerdown Options

For devices which communicate only through a detachable cable, connecting $\overline{\text{INVALID}}$ to $\overline{\text{FORCEOFF}}$ (with FORCEON = 0) may be a desirable configuration. While the cable is attached $\overline{\text{INVALID}}$ and $\overline{\text{FORCEOFF}}$ remain high, so the enhanced automatic powerdown logic powers down the RS-232 device whenever there is 30 seconds of inactivity on the receiver and transmitter inputs. Detaching the cable allows the receiver inputs to drop to an invalid level (GND), so $\overline{\text{INVALID}}$ switches low and forces the RS-232 device to power down. The ICL32XX remains powered down until the cable is reconnected ($\overline{\text{INVALID}} = \overline{\text{FORCEOFF}} = 1$) and a

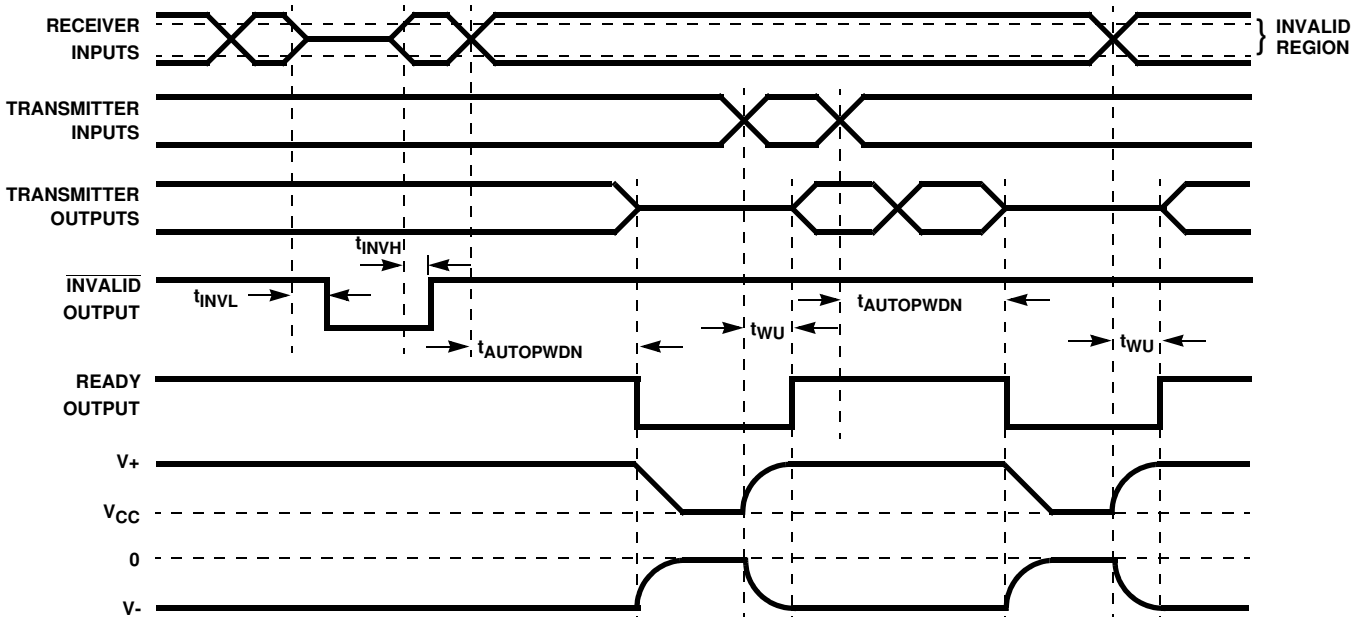

FIGURE 8. ENHANCED AUTOMATIC POWERDOWN, $\overline{\text{INVALID}}$ AND READY TIMING DIAGRAMS

transition occurs on a receiver or transmitter input (see Figure 7). For immediate power up when the cable is reattached, connect FORCEON to $\overline{\text{FORCEOFF}}$ through a network similar to that shown in Figure 5.

Ready Output (ICL3224 and ICL3226 only)

The Ready output indicates that the ICL322X is ready to transmit. Ready switches low whenever the device enters powerdown, and switches back high during power-up when V- reaches -4V or lower.

Capacitor Selection

The charge pumps require 0.1µF capacitors for 3.3V operation. For other supply voltages refer to Table 3 for capacitor values. Do not use values smaller than those listed in Table 3. Increasing the capacitor values (by a factor of 2) reduces ripple on the transmitter outputs and slightly reduces power consumption. C₂, C₃, and C₄ can be increased without increasing C₁'s value, however, do not increase C₁ without also increasing C₂, C₃, and C₄ to maintain the proper ratios (C₁ to the other capacitors).

When using minimum required capacitor values, make sure that capacitor values do not degrade excessively with temperature. If in doubt, use capacitors with a larger nominal value. The capacitor's equivalent series resistance (ESR) usually rises at low temperatures and it influences the amount of ripple on V+ and V-.

TABLE 3. REQUIRED CAPACITOR VALUES (Note 8)

V _{CC} (V)	C ₁ (µF)	C ₂ , C ₃ , C ₄ (µF)
3.0 to 3.6 (3.3V ±10%)	0.1 (0.22)	0.1 (0.22)
3.15 to 3.6 (3.3V ±5%)	(0.1)	(0.1)
4.5 to 5.5	0.047	0.33
3.0 to 5.5	0.1 (0.22)	0.47 (1.0)

NOTE:

7. Parenthesized values apply only to the ICL3238

Power Supply Decoupling

In most circumstances a 0.1µF bypass capacitor is adequate. In applications that are particularly sensitive to power supply noise, decouple V_{CC} to ground with a capacitor of the same value as the charge-pump capacitor C₁. Connect the bypass capacitor as close as possible to the IC.

Transmitter Outputs when Exiting Powerdown

Figure 10 shows the response of two transmitter outputs when exiting powerdown mode. As they activate, the two transmitter outputs properly go to opposite RS-232 levels, with no glitching, ringing, nor undesirable transients. Each transmitter is loaded with 3kΩ in parallel with 2500pF. Note that the transmitters enable only when the magnitude of the supplies exceed approximately 3V.

Operation Down to 2.7V

ICL32XX transmitter outputs meet RS-562 levels (±3.7V), at the full data rate, with V_{CC} as low as 2.7V. RS-562 levels typically ensure interoperability with RS-232 devices.

Mouse Driveability

The ICL3244 is specifically designed to power a serial mouse while operating from low voltage supplies. Figure 11 shows the transmitter output voltages under increasing load current. The on-chip switching regulator ensures the transmitters will supply at least ±5V during worst case conditions (15mA for paralleled V+ transmitters, 7.3mA for single V- transmitter).

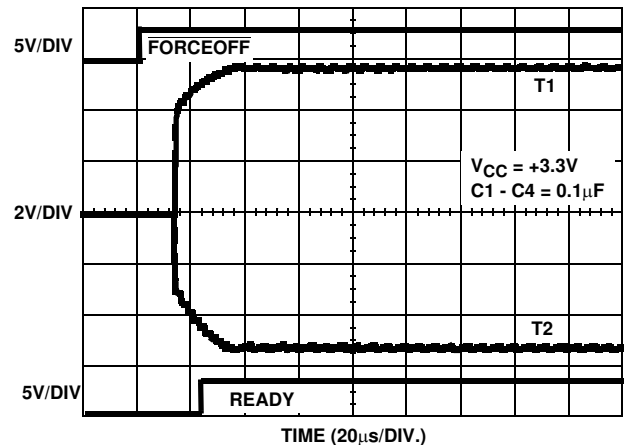

FIGURE 10. TRANSMITTER OUTPUTS WHEN EXITING POWERDOWN

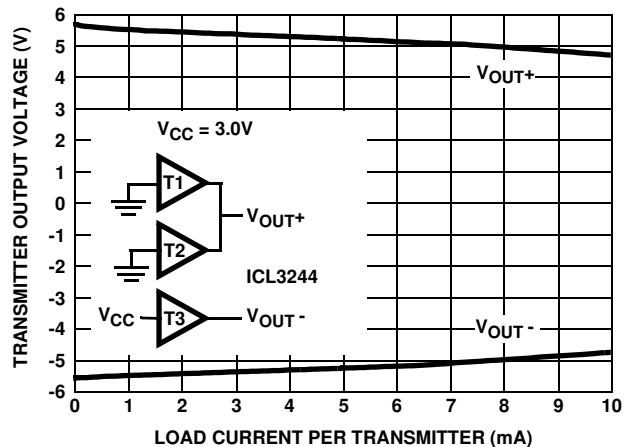

FIGURE 11. TRANSMITTER OUTPUT VOLTAGE vs LOAD CURRENT (PER TRANSMITTER, i.e., DOUBLE CURRENT AXIS FOR TOTAL V_{OUT+} CURRENT)

High Data Rates

The ICL32XX maintain the RS-232 ±5V minimum transmitter output voltages even at high data rates. Figure 12 details a transmitter loopback test circuit, and Figure 13 illustrates the loopback test result at 120kbps. For this test, all transmitters were simultaneously driving RS-232 loads in parallel with

1000pF, at 120kbps. Figure 14 shows the loopback results for a single transmitter driving 1000pF and an RS-232 load at 250kbps. The static transmitters were also loaded with an RS-232 receiver.

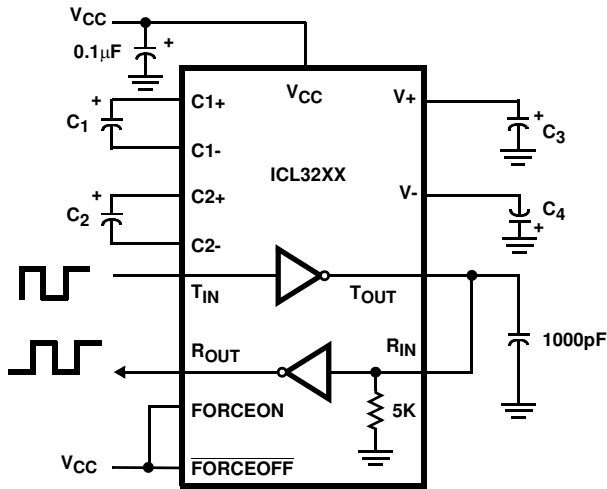

FIGURE 12. TRANSMITTER LOOPBACK TEST CIRCUIT

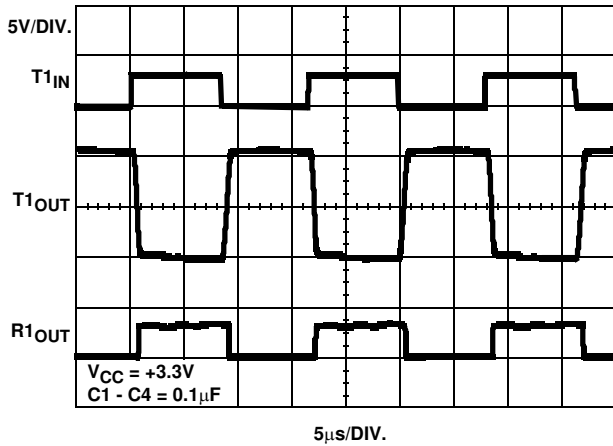

FIGURE 13. LOOPBACK TEST AT 120kbps

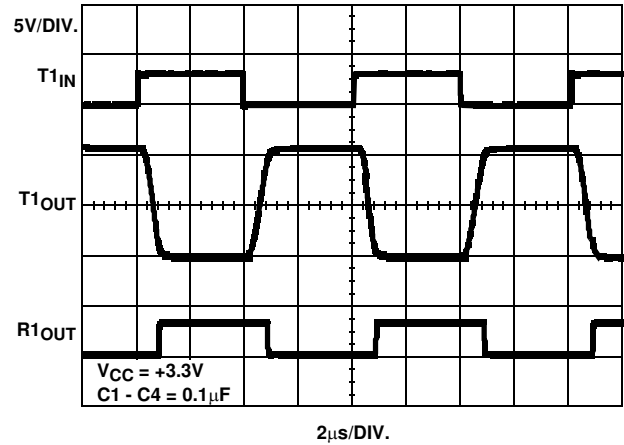

FIGURE 14. LOOPBACK TEST AT 250kbps

Interconnection with 3V and 5V Logic

The ICL32XX directly interface with 5V CMOS and TTL logic families. Nevertheless, with the ICL32XX at 3.3V, and the logic supply at 5V, AC, HC, and CD4000 outputs can drive ICL32XX inputs, but ICL32XX outputs do not reach the minimum V_{IH} for these logic families. See Table 4 for more information.

TABLE 4. LOGIC FAMILY COMPATIBILITY WITH VARIOUS SUPPLY VOLTAGES

SYSTEM POWER-SUPPLY VOLTAGE (V)	V _{CC} SUPPLY VOLTAGE (V)	COMPATIBILITY
3.3	3.3	Compatible with all CMOS families.
5	5	Compatible with all TTL and CMOS logic families.
5	3.3	Compatible with ACT and HCT CMOS, and with TTL. ICL32XX outputs are incompatible with AC, HC, and CD4000 CMOS inputs.

Typical Performance Curves $V_{CC} = 3.3V, T_A = 25^\circ C$

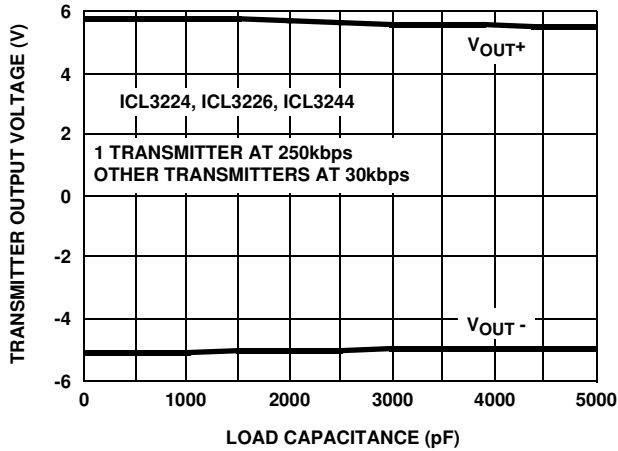

FIGURE 15. TRANSMITTER OUTPUT VOLTAGE vs LOAD CAPACITANCE

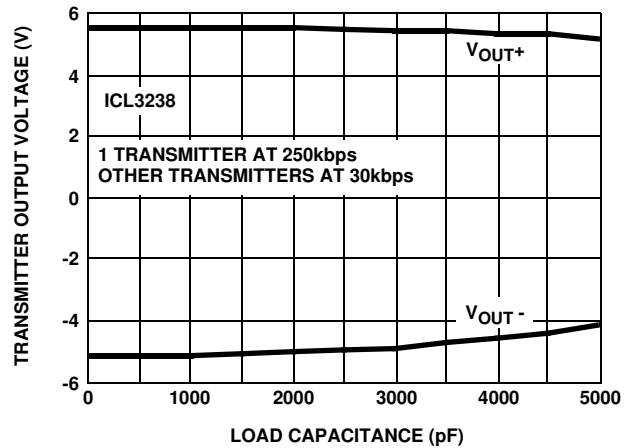

FIGURE 16. TRANSMITTER OUTPUT VOLTAGE vs LOAD CAPACITANCE

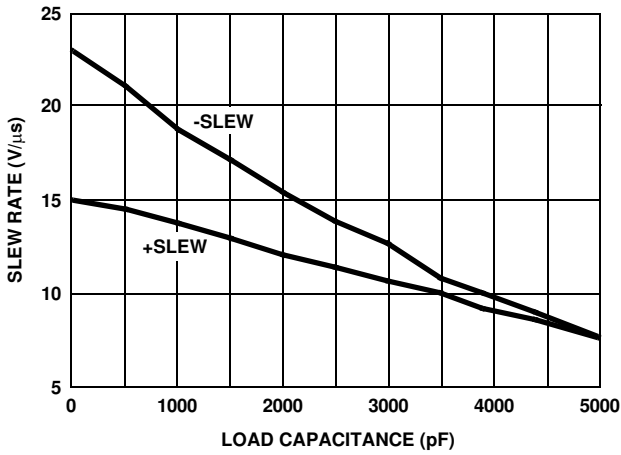

FIGURE 17. SLEW RATE vs LOAD CAPACITANCE

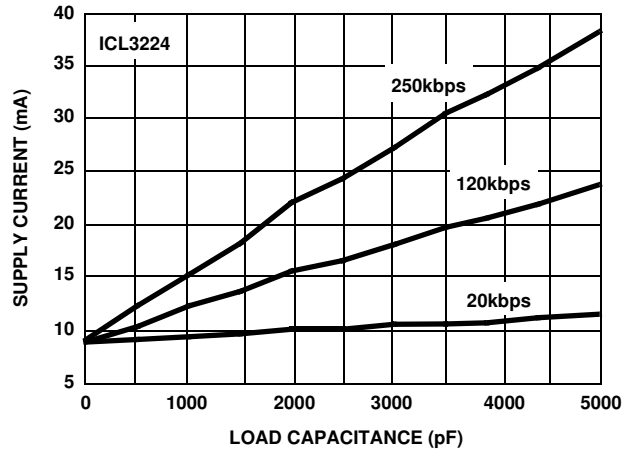

FIGURE 18. SUPPLY CURRENT vs LOAD CAPACITANCE WHEN TRANSMITTING DATA

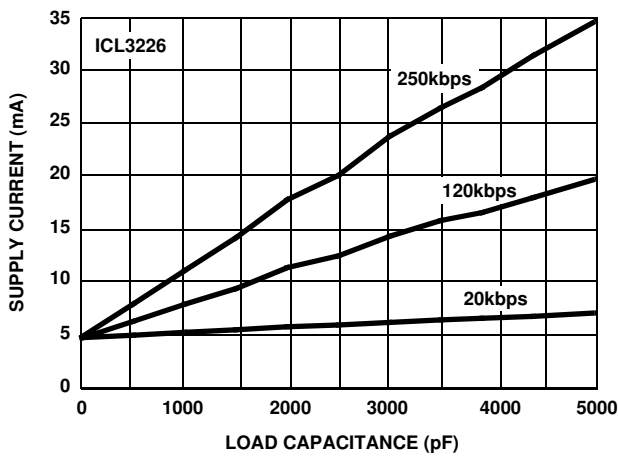

FIGURE 19. SUPPLY CURRENT vs LOAD CAPACITANCE WHEN TRANSMITTING DATA

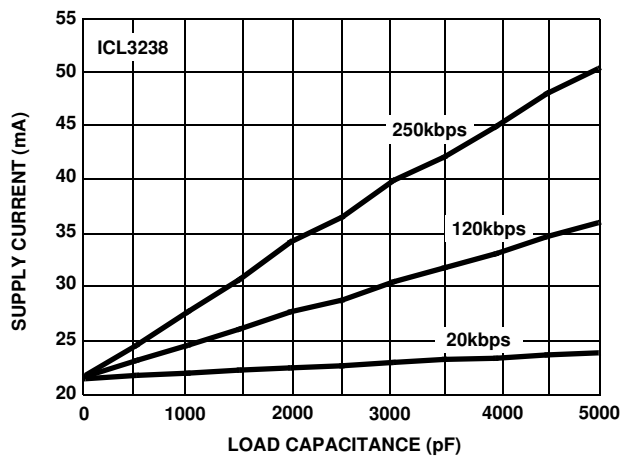

FIGURE 20. SUPPLY CURRENT vs LOAD CAPACITANCE WHEN TRANSMITTING DATA

Typical Performance Curves $V_{CC} = 3.3V, T_A = 25^\circ C$ (Continued)

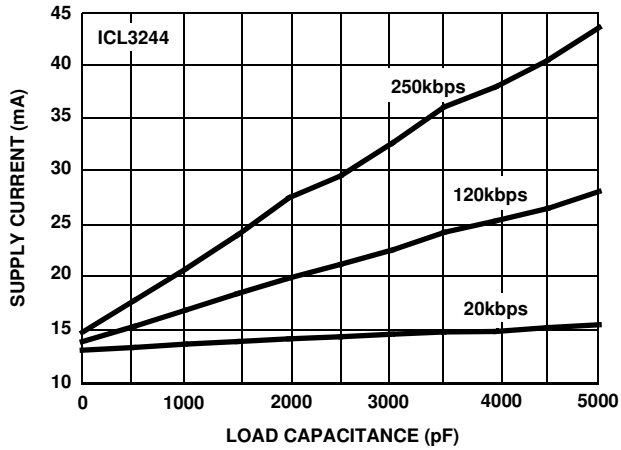

FIGURE 21. SUPPLY CURRENT vs LOAD CAPACITANCE WHEN TRANSMITTING DATA

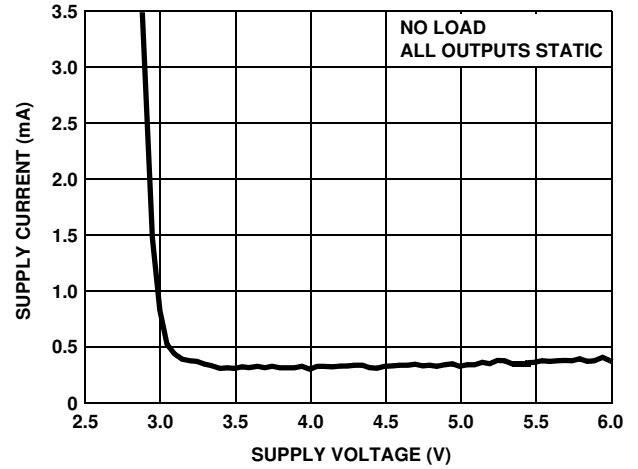

FIGURE 22. SUPPLY CURRENT vs SUPPLY VOLTAGE

Die Characteristics

SUBSTRATE POTENTIAL (POWERED UP):

GND

TRANSISTOR COUNT:

- ICL3224: 937
- ICL3226: 825
- ICL3238: 1235
- ICL3244: 1109

PROCESS:

Si Gate CMOS

Small Outline Plastic Packages (SSOP)

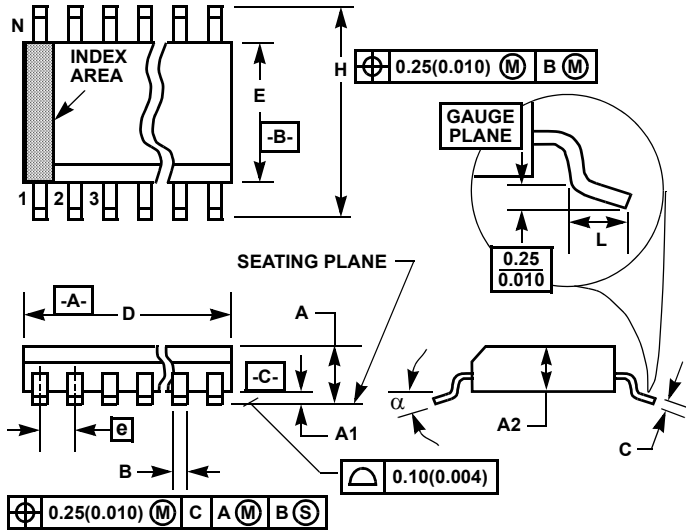

M16.209 (JEDEC MO-150-AC ISSUE B)
16 LEAD SHRINK SMALL OUTLINE PLASTIC PACKAGE

SYMBOL	INCHES		MILLIMETERS		NOTES
	MIN	MAX	MIN	MAX	
A	-	0.078	-	2.00	-
A1	0.002	-	0.05	-	-
A2	0.065	0.072	1.65	1.85	-
B	0.009	0.014	0.22	0.38	9
C	0.004	0.009	0.09	0.25	-
D	0.233	0.255	5.90	6.50	3
E	0.197	0.220	5.00	5.60	4
e	0.026 BSC		0.65 BSC		-
H	0.292	0.322	7.40	8.20	-
L	0.022	0.037	0.55	0.95	6
N	16		16		7
α	0°	8°	0°	8°	-

NOTES:

- Symbols are defined in the "MO Series Symbol List" in Section 2.2 of Publication Number 95.
- Dimensioning and tolerancing per ANSI Y14.5M-1982.
- Dimension "D" does not include mold flash, protrusions or gate burrs. Mold flash, protrusion and gate burrs shall not exceed 0.20mm (0.0078 inch) per side.
- Dimension "E" does not include interlead flash or protrusions. Interlead flash and protrusions shall not exceed 0.20mm (0.0078 inch) per side.
- The chamfer on the body is optional. If it is not present, a visual index feature must be located within the crosshatched area.
- "L" is the length of terminal for soldering to a substrate.
- "N" is the number of terminal positions.
- Terminal numbers are shown for reference only.
- Dimension "B" does not include dambar protrusion. Allowable dambar protrusion shall be 0.13mm (0.005 inch) total in excess of "B" dimension at maximum material condition.
- Controlling dimension: MILLIMETER. Converted inch dimensions are not necessarily exact.

Rev. 3 6/05

Shrink Small Outline Plastic Packages (SSOP)

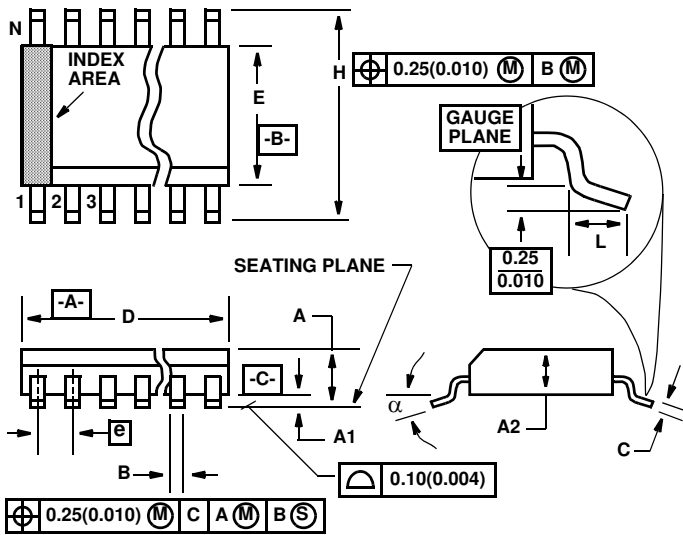

M20.209 (JEDEC MO-150-AE ISSUE B)
20 LEAD SHRINK SMALL OUTLINE PLASTIC PACKAGE

SYMBOL	INCHES		MILLIMETERS		NOTES
	MIN	MAX	MIN	MAX	
A	0.068	0.078	1.73	1.99	
A1	0.002	0.008'	0.05	0.21	
A2	0.066	0.070'	1.68	1.78	
B	0.010'	0.015	0.25	0.38	9
C	0.004	0.008	0.09	0.20'	
D	0.278	0.289	7.07	7.33	3
E	0.205	0.212	5.20'	5.38	4
e	0.026 BSC		0.65 BSC		
H	0.301	0.311	7.65	7.90'	
L	0.025	0.037	0.63	0.95	6
N	20		20		7
α	0 deg.	8 deg.	0 deg.	8 deg.	

NOTES:

1. Symbols are defined in the "MO Series Symbol List" in Section 2.2 of Publication Number 95.
2. Dimensioning and tolerancing per ANSI Y14.5M-1982.
3. Dimension "D" does not include mold flash, protrusions or gate burrs. Mold flash, protrusion and gate burrs shall not exceed 0.20mm (0.0078 inch) per side.
4. Dimension "E" does not include interlead flash or protrusions. Interlead flash and protrusions shall not exceed 0.20mm (0.0078 inch) per side.
5. The chamfer on the body is optional. If it is not present, a visual index feature must be located within the crosshatched area.
6. "L" is the length of terminal for soldering to a substrate.
7. "N" is the number of terminal positions.
8. Terminal numbers are shown for reference only.
9. Dimension "B" does not include dambar protrusion. Allowable dambar protrusion shall be 0.13mm (0.005 inch) total in excess of "B" dimension at maximum material condition.
10. Controlling dimension: MILLIMETER. Converted inch dimensions are not necessarily exact.

Rev. 3 11/02

Shrink Small Outline Plastic Packages (SSOP)

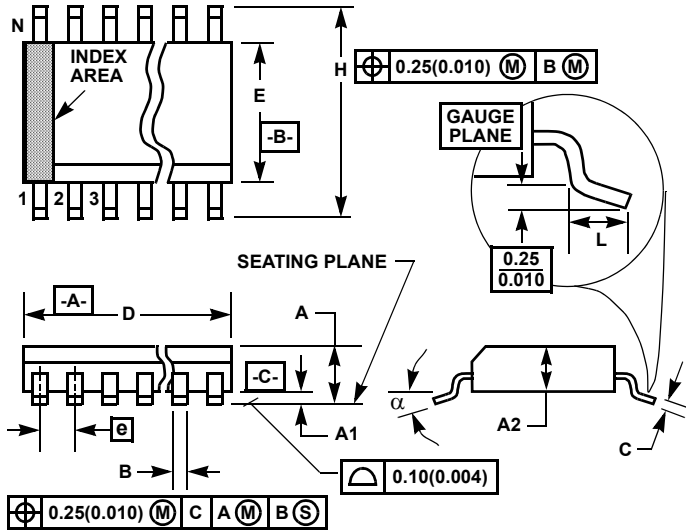

M28.209 (JEDEC MO-150-AH ISSUE B)
28 LEAD SHRINK SMALL OUTLINE PLASTIC PACKAGE

SYMBOL	INCHES		MILLIMETERS		NOTES
	MIN	MAX	MIN	MAX	
A	-	0.078	-	2.00	-
A1	0.002	-	0.05	-	-
A2	0.065	0.072	1.65	1.85	-
B	0.009	0.014	0.22	0.38	9
C	0.004	0.009	0.09	0.25	-
D	0.390	0.413	9.90	10.50	3
E	0.197	0.220	5.00	5.60	4
e	0.026 BSC		0.65 BSC		-
H	0.292	0.322	7.40	8.20	-
L	0.022	0.037	0.55	0.95	6
N	28		28		7
α	0°	8°	0°	8°	-

NOTES:

1. Symbols are defined in the "MO Series Symbol List" in Section 2.2 of Publication Number 95.
2. Dimensioning and tolerancing per ANSI Y14.5M-1982.
3. Dimension "D" does not include mold flash, protrusions or gate burrs. Mold flash, protrusion and gate burrs shall not exceed 0.20mm (0.0078 inch) per side.
4. Dimension "E" does not include interlead flash or protrusions. Interlead flash and protrusions shall not exceed 0.20mm (0.0078 inch) per side.
5. The chamfer on the body is optional. If it is not present, a visual index feature must be located within the crosshatched area.
6. "L" is the length of terminal for soldering to a substrate.
7. "N" is the number of terminal positions.
8. Terminal numbers are shown for reference only.
9. Dimension "B" does not include dambar protrusion. Allowable dambar protrusion shall be 0.13mm (0.005 inch) total in excess of "B" dimension at maximum material condition.
10. Controlling dimension: MILLIMETER. Converted inch dimensions are not necessarily exact.

Rev. 2 6/05

All Intersil U.S. products are manufactured, assembled and tested utilizing ISO9000 quality systems. Intersil Corporation's quality certifications can be viewed at www.intersil.com/design/quality

Intersil products are sold by description only. Intersil Corporation reserves the right to make changes in circuit design, software and/or specifications at any time without notice. Accordingly, the reader is cautioned to verify that data sheets are current before placing orders. Information furnished by Intersil is believed to be accurate and reliable. However, no responsibility is assumed by Intersil or its subsidiaries for its use; nor for any infringements of patents or other rights of third parties which may result from its use. No license is granted by implication or otherwise under any patent or patent rights of Intersil or its subsidiaries.

For information regarding Intersil Corporation and its products, see www.intersil.com