



Chipsmall Limited consists of a professional team with an average of over 10 year of expertise in the distribution of electronic components. Based in Hongkong, we have already established firm and mutual-benefit business relationships with customers from,Europe,America and south Asia,supplying obsolete and hard-to-find components to meet their specific needs.

With the principle of “Quality Parts,Customers Priority,Honest Operation,and Considerate Service”,our business mainly focus on the distribution of electronic components. Line cards we deal with include Microchip,ALPS,ROHM,Xilinx,Pulse,ON,Everlight and Freescale. Main products comprise IC,Modules,Potentiometer,IC Socket,Relay,Connector.Our parts cover such applications as commercial,industrial, and automotives areas.

We are looking forward to setting up business relationship with you and hope to provide you with the best service and solution. Let us make a better world for our industry!



Contact us

Tel: +86-755-8981 8866 Fax: +86-755-8427 6832

Email & Skype: info@chipsmall.com Web: www.chipsmall.com

Address: A1208, Overseas Decoration Building, #122 Zhenhua RD., Futian, Shenzhen, China



MAXIM

Chopper-Stabilized Op Amps

General Description

Maxim's ICL7650/ICL7653 are chopper-stabilized amplifiers, ideal for low-level signal processing applications. Featuring high performance and versatility, these devices combine low input offset voltage, low input bias current, wide bandwidth, and exceptionally low drift over time and temperature. Low offset is achieved through a nulling scheme that provides continuous error correction. A nulling amplifier alternately nulls itself and the main amplifier. The result is an input offset voltage that is held to a minimum over the entire operating temperature range.

The ICL7650B/ICL7653B are exact replacements for Intersil's ICL7650B/ICL7653B. These devices have a $10\mu\text{V}$ max offset voltage, a $0.1\mu\text{V}/^\circ\text{C}$ max input offset voltage temperature coefficient, and a 20pA max bias current—all specified over the commercial temperature range.

A 14-pin version is available that can be used with either an internal or external clock. The 14-pin version has an output voltage clamp circuit to minimize over-load recovery time.

Applications

Condition Amplifier
Precision Amplifier
Instrumentation Amplifier
Thermocouples
Thermistors
Strain Gauges

Typical Operating Circuit

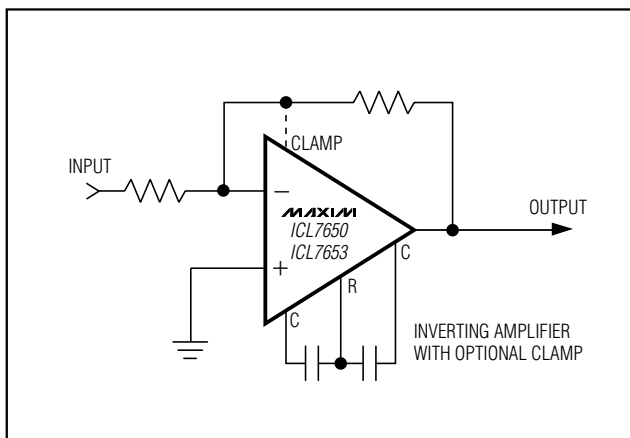

Features

- ◆ ICL7650/53 are Improved Second Sources to ICL7650B/53B
- ◆ Lower Supply Current: 2mA
- ◆ Low Offset Voltage: $1\mu\text{V}$
- ◆ No Offset Voltage Trimming Needed
- ◆ High-Gain CMRR and PSRR: 120dB min
- ◆ Lower Offset Drift with Time and Temperature
- ◆ Extended Common-Mode Voltage Range
- ◆ Low DC Input Bias Current: 10pA
- ◆ Monolithic, Low-Power CMOS Design

Ordering Information

PART	TEMP. RANGE	PIN-PACKAGE
ICL7650CSA	0°C to $+70^\circ\text{C}$	8 SO
ICL7650CSD	0°C to $+70^\circ\text{C}$	14 SO
ICL7650CPA	0°C to $+70^\circ\text{C}$	8 Plastic DIP
ICL7650CPD	0°C to $+70^\circ\text{C}$	14 Plastic DIP
ICL7650CTV	0°C to $+70^\circ\text{C}$	8 TO-99
ICL7650C/D	0°C to $+70^\circ\text{C}$	Dice
ICL7650IJA	-20°C to $+85^\circ\text{C}$	8 CERDIP
ICL7650IJD	-20°C to $+85^\circ\text{C}$	14 CERDIP
ICL7650MTV	-55°C to $+125^\circ\text{C}$	8 CERDIP
ICL7650MJD	-55°C to $+125^\circ\text{C}$	14 CERDIP
ICL7650BCSA	0°C to $+70^\circ\text{C}$	8 SO
ICL7650BCSD	0°C to $+70^\circ\text{C}$	14 SO
ICL7650BCPA	0°C to $+70^\circ\text{C}$	8 Plastic DIP
ICL7650BCPD	0°C to $+70^\circ\text{C}$	14 Plastic DIP
ICL7650BCTV	0°C to $+70^\circ\text{C}$	8 TO-99
ICL7650BC/D	0°C to $+70^\circ\text{C}$	Dice
ICL7653CSA	0°C to $+70^\circ\text{C}$	8 SO
ICL7653CPA	0°C to $+70^\circ\text{C}$	8 Plastic DIP
ICL7653CTV	0°C to $+70^\circ\text{C}$	8 TO-99
ICL7653IJA	-20°C to $+85^\circ\text{C}$	8 CERDIP
ICL7653MTV	-55°C to $+125^\circ\text{C}$	8 CERDIP
ICL7653BCSA	0°C to $+70^\circ\text{C}$	8 SO
ICL7653BCPA	0°C to $+70^\circ\text{C}$	8 Plastic DIP
ICL7653BCTV	0°C to $+70^\circ\text{C}$	8 TO-99

Pin Configurations appear at end of data sheet.

MAXIM

Maxim Integrated Products 1

For free samples and the latest literature, visit www.maxim-ic.com or phone 1-800-998-8800.
For small orders, phone 1-800-835-8769.

ICL7650/ICL7650B/ICL7653/ICL7653B

Chopper-Stabilized Op Amps

ABSOLUTE MAXIMUM RATINGS

Total Supply Voltage (V+ to V-).....	18V	8-Pin TO-99 (derate 6.7mW/°C above +70°C).....	533mW
Input Voltage(V+ + 0.3V) to (V- - 0.3V)		14-Pin SO (derate 8.3mW/°C above +70°C).....	667mW
Voltage on Oscillator Control Pins (except EXT/CLOCK IN).....	V+ to V-	14-Pin PDIP (derate 10.0mW/°C above +70°C).....	800mW
Voltage on EXT/CLOCK IN.....(V+ + 0.3V) to (V+ - 6.0V)		14-Pin CERDIP (derate 9.1mW/°C above +70°C).....	727mW
Duration of Output Short Circuit	Indefinite	Operating Temperature Ranges	
Current into Any Pin	10mA	ICL765_C_/ICL755_BC_	0°C to +70°C
Current into Any Pin while Operating (Note 1).....	100µA	ICL765_I_/ICL755_BI_	-20°C to +85°C
Continuous Total Power Dissipation (TA = +70°C)		ICL765_M_/ICL755_BM_	-55°C to +125°C
8-Pin SO (derate 5.88mW/°C above +70°C).....	471mW	Storage Temperature Range	-65°C to +150°C
8-Pin PDIP (derate 6.9mW/°C above +70°C).....	552mW	Junction Temperature	+150°C
8-Pin CERDIP (derate 8.0mW/°C above +70°C).....	640mW	Lead Temperature (soldering, 10s)	+300°C

Note 1: Maxim recommends limiting the input current to 100µA to avoid latchup problems. A value of 1mA is typically safe; however, this is not guaranteed.

Stresses beyond those listed under "Absolute Maximum Ratings" may cause permanent damage to the device. These are stress ratings only, and functional operation of the device at these or any other conditions beyond those indicated in the operational sections of the specifications is not implied. Exposure to absolute maximum rating conditions for extended periods may affect device reliability.

ELECTRICAL CHARACTERISTICS—ICL7650B/ICL7653B

(Circuit of Figure 1, V+ = +5V, V- = -5V, TA = +25°C, unless otherwise noted.)

PARAMETER	SYMBOL	CONDITIONS	MIN	TYP	MAX	UNITS	
Input Offset Voltage	VOS	TA = +25°C		±0.7	±5	µV	
		-55°C < TA < +85°C		±10			
		-55°C < TA < +125°C			5.0		
Average Temperature Coefficient of Input Offset Voltage	$\frac{\Delta V_{OS}}{\Delta T}$	TA = +25°C		50		µV/°C	
		-20°C < TA < +85°C		0.01	0.05		
Input Bias Current	IBIAS	Doubles every 10°		TA = +25°C	1.5	10	pA
				0°C < TA < +70°C	35		
				-20°C < TA < +85°C	100		
Input Offset Current (Note 2)	IOS	TA = +25°C		0.5		pA	
Input Resistance	RIN			10 ¹²		Ω	
Large-Signal Voltage Gain	AVOL	RL = 10kΩ	1 · 10 ⁵	5 · 10 ⁸		V/V	
Output Voltage Swing (Note 3)	VOUT	RL = 10kΩ	±4.7	±4.85		V	
		RL = 100kΩ		±4.95			
Common-Mode Voltage Range	CMVR		-5.0	-5.2 to +2.0	1.6	V	
Common-Mode Rejection Ratio	CMRR	CMVR = -5V to +1.6V	120	130		dB	
Power-Supply Rejection Ratio	PSRR	V+ to V- = ±3V to ±8V	120	130		dB	
Input Noise Voltage	e _{np-p}	RS = 100Ω, f = 0 to 10Hz		2		µVp-p	
Input Noise Current	I _n	f = 10Hz		0.01		pA/√Hz	
Unity-Gain Bandwidth	GBW			2.0		MHz	
Slew Rate	SR	CL = 50pF, RL = 10kΩ		2.5		V/µs	
Rise Time	tr			0.2		µs	
Overshoot				20		%	
Operating Supply Range	V+ to V-		4.5		16	V	
Supply Current	ISUPP	No load		2.0	3.5	mA	

Chopper-Stabilized Op Amps

ICL7650/ICL7650B/ICL7653/ICL7653B

ELECTRICAL CHARACTERISTICS—ICL7650B/ICL7653B (continued)

(Circuit of Figure 1, $V_+ = +5V$, $V_- = -5V$, $T_A = +25^\circ C$, unless otherwise noted.)

PARAMETER	SYMBOL	CONDITIONS	MIN	TYP	MAX	UNITS
Internal Chopping Frequency	f_{ch}	Pins 12–14 open (DIP)	120	200	375	Hz
Clamp On Current (Note 4)		$R_L = 100k\Omega$	25	70	200	μA
Clamp Off Current (Note 4)		$-4.0V < V_{OUT} < +4.0V$		1		μA
Offset Voltage vs. Time		No load		100		$\frac{nV}{\sqrt{month}}$

Note 2: $I_{OS} = 2 \cdot I_{BIAS}$

Note 3: OUTPUT and CLAMP pins not connected.

Note 4: See *Output Clamp* section for details.

ELECTRICAL CHARACTERISTICS—ICL7650/ICL7653

(Circuit of Figure 1, $V_+ = +5V$, $V_- = -5V$, $T_A = +25^\circ C$, unless otherwise noted.) (Note 5)

PARAMETER	SYMBOL	CONDITIONS	MIN	TYP	MAX	UNITS
Input Offset Voltage	V_{OS}	$T_A = +25^\circ C$	ICL765_	± 0.7	± 5.0	μV
			ICL765_B	± 1.0	± 10	
		ICL765_ (Note 6)	$0^\circ C \leq T_A \leq +70^\circ C$	± 1.0	± 10	
			$-20^\circ C \leq T_A \leq +85^\circ C$	± 1.0	± 10	
			$-55^\circ C \leq T_A \leq +125^\circ C$	± 10	± 50	
Average Temperature Coefficient of Input Offset Voltage (Note 6)	$\frac{\Delta V_{OS}}{\Delta T}$	ICL765_B, $0^\circ C \leq T_A \leq +70^\circ C$	$0^\circ C \leq T_A \leq +70^\circ C$	0.01	0.05	$\mu V/^\circ C$
			$-20^\circ C \leq T_A \leq +85^\circ C$	0.01	0.05	
			$-55^\circ C \leq T_A \leq +85^\circ C$	0.01	0.05	
			$+85^\circ C \leq T_A \leq +125^\circ C$	0.25	1.5	
		ICL765_				
Input Bias Current	I_B	$T_A = +25^\circ C$	ICL765_	4	10	μA
			ICL765_B	12	20	
		ICL765_	$0^\circ C \leq T_A \leq +70^\circ C$	20	100	
			$-20^\circ C \leq T_A \leq +85^\circ C$	50	200	
			$-55^\circ C \leq T_A \leq +125^\circ C$	0.3	10	
Input Resistance	R_{IN}		10^{12}		Ω	
Large-Signal Voltage Gain	A_{VOL}	$R_L = 10k\Omega$, $T_A = +25^\circ C$	$1 \cdot 10^8$	$5 \cdot 10^8$	V/V	
		$0^\circ C \leq T_A \leq +70^\circ C$	$0.5 \cdot 10^8$			
		$-20^\circ C \leq T_A \leq +85^\circ C$	$0.5 \cdot 10^8$			
		$-55^\circ C \leq T_A \leq +125^\circ C$	$0.2 \cdot 10^8$			
Output Voltage Swing (Note 3)	V_{OUT}	$R_L = 10k\Omega$	± 4.7	± 4.85	V	
		$R_L = 100k\Omega$		± 4.95		
Common-Mode Voltage Range	CMVR	$0^\circ C \leq T_A \leq +70^\circ C$	-5.0	-5.2 to +3.0	2.5	V
		$-20^\circ C \leq T_A \leq +85^\circ C$	-5.0	-5.2 to +3.0	2.5	
		$-55^\circ C \leq T_A \leq +125^\circ C$	-4.5	-4.0 to +3.0	2.5	

Chopper-Stabilized Op Amps

ELECTRICAL CHARACTERISTICS—ICL7650/ICL7653 (continued)

(Circuit of Figure 1, $V_+ = +5V$, $V_- = -5V$, $T_A = +25^\circ C$, unless otherwise noted.) (Note 5)

PARAMETER	SYMBOL	CONDITIONS	MIN	TYP	MAX	UNITS
Common-Mode Rejection Ratio	CMRR	CMVR = -5V to +2.5V	120	130		dB
Power-Supply Rejection Ratio	PSRR	V_+ to $V_- = \pm 3V$ to $\pm 8V$	120	130		dB
Input Noise Voltage	e_{np-p}	$R_S = 100\Omega$, $f = 0$ to 10Hz		2		μV_{p-p}
Input Noise Current	I_n	$f = 10Hz$		0.01		pA/\sqrt{Hz}
Unity-Gain Bandwidth	GBW			2.0		MHz
Slew Rate	SR	$C_L = 50pF$, $R_L = 10k\Omega$		2.5		$V/\mu s$
Rise Time	t_r			0.2		μs
Overshoot				20		%
Operating Supply Range	V_+ to V_-		4.5		16	V
Supply Current	I_{SUPP}	No load		1.2	2.0	mA
Internal Chopping Frequency	f_{CLKOUT}	Pins 13 and 14 open (DIP)	120	200	375	Hz
Clamp On Current (Note 4)		$R_L = 100k\Omega$	25	70	200	μA
Clamp Off Current (Note 4)		$-4.0 \leq V_{OUT} \leq +4.0V$		1		pA
Offset Voltage vs. Time				100		$\frac{nV}{\sqrt{month}}$

Note 3: OUTPUT and CLAMP pins not connected.

Note 4: See *Output Clamp* section for details.

Note 5: All pins are designed to withstand electrostatic discharge (ESD) levels in excess of 2000V (MIL STD 8838 Method 3015.1 test circuit).

Note 6: Sample tested. Limits are not used to calculate outgoing quality level.

Typical Operating Characteristics

(Circuit of Figure 1, $V_+ = +5V$, $V_- = -5V$, $T_A = +25^\circ C$, unless otherwise noted.)

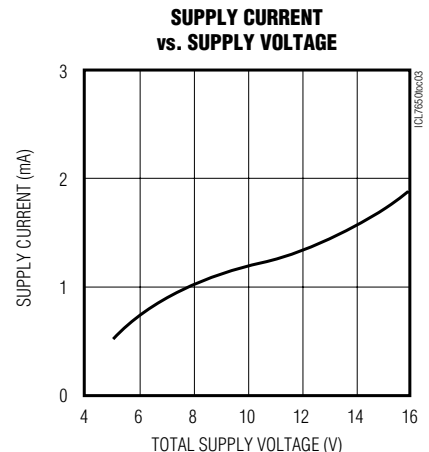
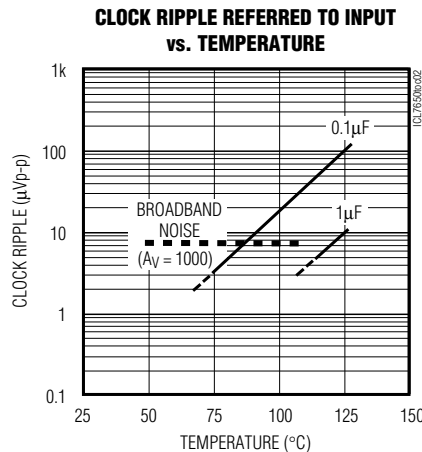
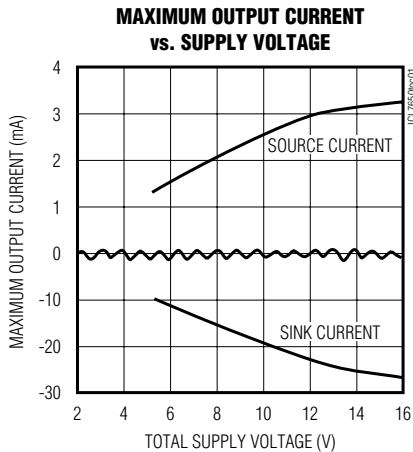

Chopper-Stabilized Op Amps

Typical Operating Characteristics (continued)

(Circuit of Figure 1, $V_+ = +5V$, $V_- = -5V$, $T_A = +25^\circ C$, unless otherwise noted.)

ICL7650/ICL7650B/ICL7653/ICL7653B

SUPPLY CURRENT vs. AMBIENT TEMPERATURE

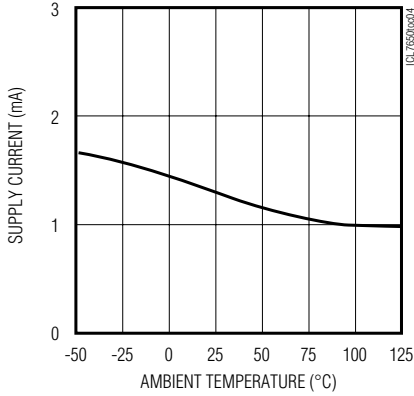

COMMON-MODE INPUT VOLTAGE RANGE vs. SUPPLY VOLTAGE

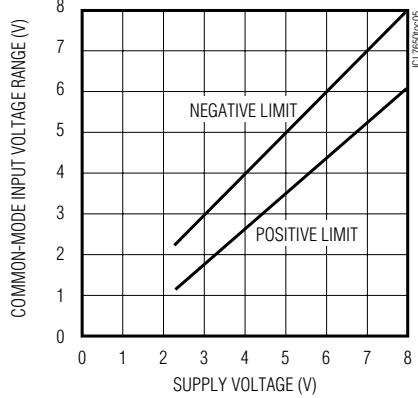

INPUT OFFSET VOLTAGE vs. CHOPPING FREQUENCY

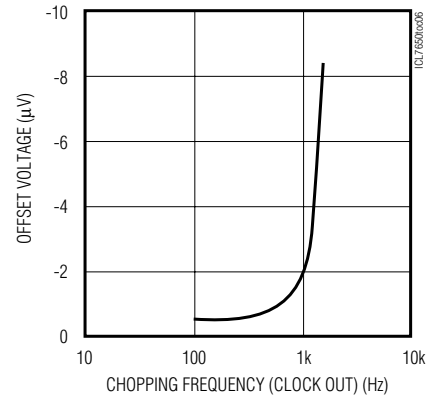

INPUT OFFSET VOLTAGE CHANGE vs. SUPPLY VOLTAGE

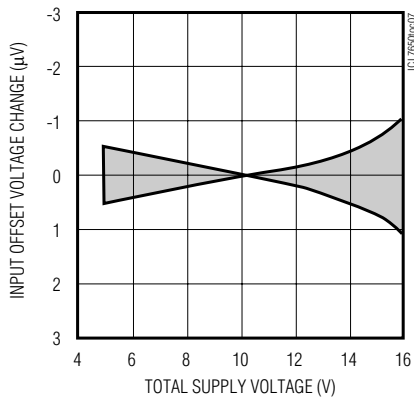

10Hzp-p Noise Voltage vs. CHOPPING FREQUENCY

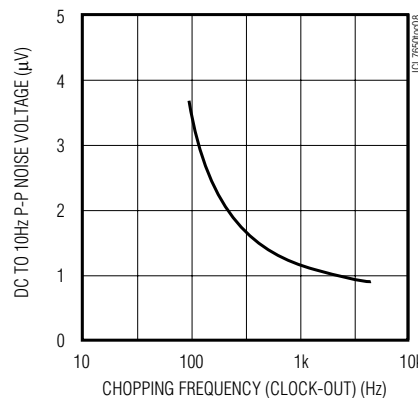

OPEN-LOOP GAIN AND PHASE SHIFT vs. FREQUENCY

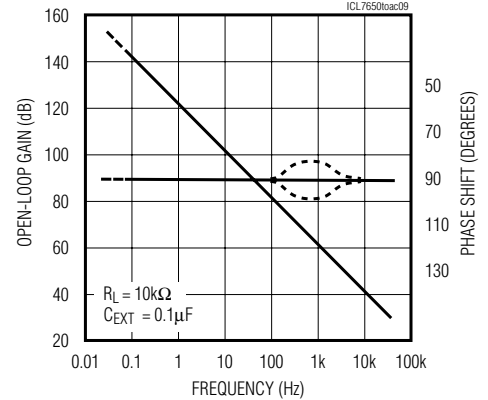

OPEN-LOOP GAIN AND PHASE SHIFT vs. FREQUENCY

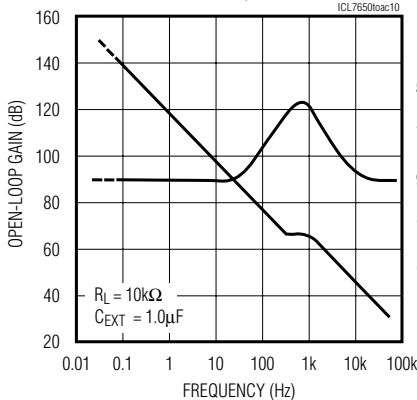

VOLTAGE FOLLOWER LARGE-SIGNAL PULSE RESPONSE

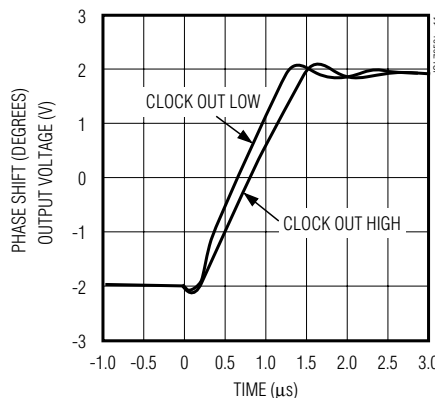

VOLTAGE FOLLOWER LARGE-SIGNAL PULSE RESPONSE

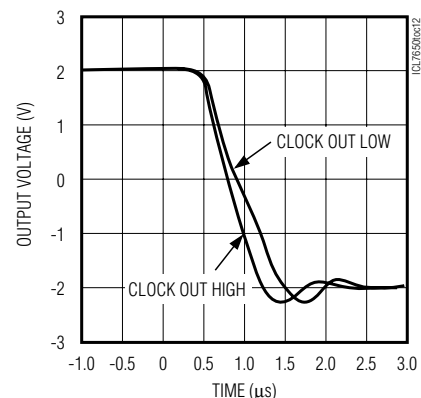

Chopper-Stabilized Op Amps

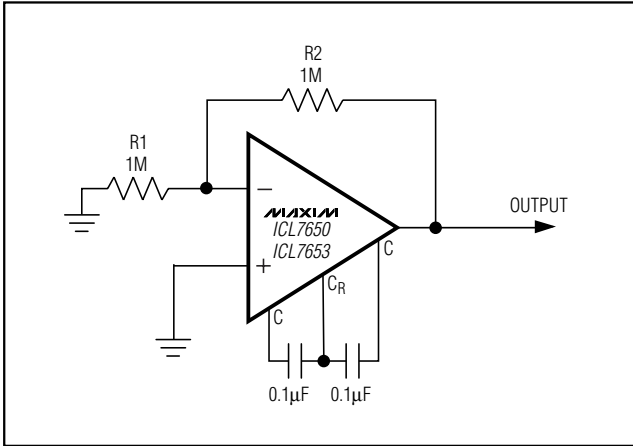

Figure 1. ICL7650 Test Circuit

Detailed Description

Figure 2 shows the major elements of the ICL7650/ICL7653. Two amplifiers are illustrated, the main amplifier and the nulling amplifier, both of which have offset-null capability. The main amplifier is connected full time from the input to the output. The nulling amplifier, under control of the chopper-frequency oscillator and clock circuit, alternately nulls itself and the main amplifier. This nulling arrangement, which is independent of the output level, operates over the full power-supply and common-mode ranges. The ICL7650/ICL7653 exhibit an exceptionally high CMRR, PSRR, and A_{VOL} . Their nulling connections, which are MOSFET back gates, have inherently high impedance. Two external capacitors provide storage for the nulling potentials and the necessary nulling-loop time constants.

The ICL7650/ICL7653 minimize chopper-frequency charge injection at the input terminals by carefully balancing the input switches. Feed-forward injection into the compensation capacitor, the main cause of output spikes in this type of circuit, is also minimized.

Output Clamp (ICL7650 Only)

The output clamp reduces the overload recovery time inherent with chopper-stabilized amplifiers. When tied to the summing junction or inverting input pin, a current path between this point and the output occurs just before the output device saturates. This prevents uncontrolled input differential and the consequent charge build-up on the correction-storage capacitors, while causing only a slight reduction in the output swing.

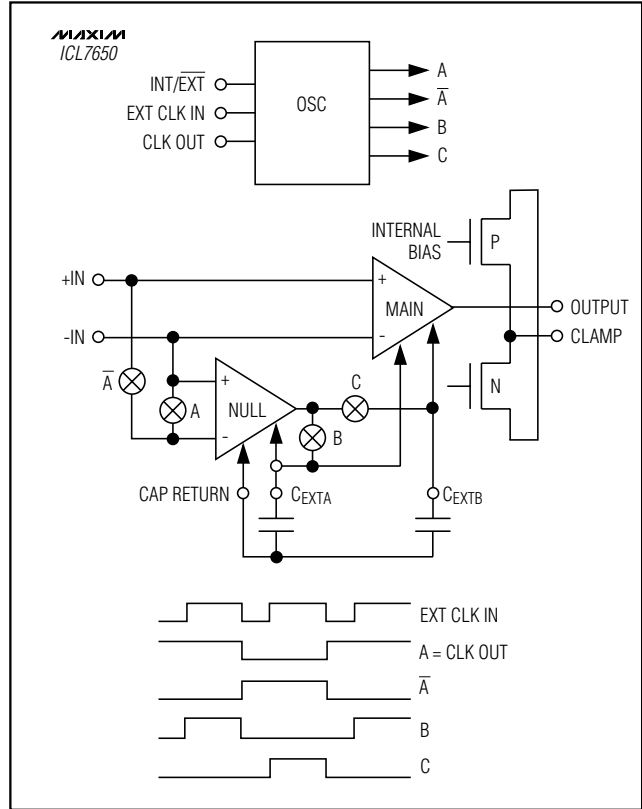

Figure 2. Block Diagram

Intermodulation

Intermodulation effects can cause problems in older chopper-stabilized amplifier modules. Intermodulation occurs since the amplifier has a finite AC gain, and therefore will have a small AC signal at the input. In a chopper-stabilized module, this small AC signal is detected, chopped, and fed into the offset-correction circuit. This results in spurious outputs at the sum and difference frequencies of the chopping and input signal frequencies. Other intermodulation effects in chopper-stabilized modules include gain and phase anomalies near the chopping frequency.

These effects are substantially reduced in the ICL7650/ICL7653, which add to the nulling circuit a dynamic current that compensates for the AC signal on the inputs. Unlike modules, the ICL7650/ICL7653 can precisely compensate for the finite AC gain, since both the AC gain rolloff and the intermodulation compensation current are controlled by internal matched capacitors.

Chopper-Stabilized Op Amps

ICL7650/ICL7650B/ICL7653/ICL7653B

Nulling Capacitor Connection

Separate pins are provided for C_{RETN} and CLAMP in the ICL7650. If you do not need the clamp feature, order the ICL7653; this device only offers the C_{RETN} pin and will produce slightly lower noise and improved AC common-mode rejection. If you need to use the clamp feature, order the ICL7650 and connect the external capacitors to V-. To prevent load-current IR drops and other extraneous signals from being injected into the capacitors, use a separate PC board trace to connect the capacitor commons directly to the V- pin. The outside foil of the capacitors should be connected to the low-impedance side of the null storage circuit, V- or C_{RETN} . This will act as an ESD voltage shield.

Clock Operation

The ICL7650's internal oscillator generates a 200Hz frequency, which is available at the CLK OUT pin. The device can also be operated with an external clock, if desired. An internal pull-up permits the INT/EXT pin to be left open for normal operation. However, the internal clock must be disabled and INT/EXT must be tied to V- if an external clock is used. An external clock signal may then be applied to the EXT CLK IN pin. The duty cycle of the external clock is not critical at low frequencies. However, a 50% to 80% positive duty cycle is preferred for frequencies above 500Hz, since the capacitors are charged only when EXT CLK IN is high. This ensures that any transients have time to settle before the capacitors are turned off. The external clock should swing between ground and V+ for power supplies up to $\pm 6V$, and between V+ and (V+ - 6V) for higher supply voltages.

To avoid a capacitor imbalance during overload, use a strobe signal. Neither capacitor will be charged if a strobe signal is connected to EXT CLK IN so that it is low while the overload signal is being applied to the amplifier. A typical amplifier will drift less than 10 μV s since the leakage of the capacitor pins is quite low at room temperature. Relatively long measurements may be made with little change in offset.

Applications Information

Device Selection

In applications that require lowest noise, Maxim's ICL7652 may be preferred over the ICL7650/ICL7653. The ICL7650/ICL7653 offer a higher gain-bandwidth product and lower input bias currents, while the ICL7652 reduces noise by using larger input FETs. These larger FETs, however, increase the leakage at the ICL7652's external null pins. Therefore, the ICL7650/ICL7653 can operate to a higher temperature with 0.1 μF capacitors before the clock ripple (due to

leakage at the null capacitor pins) becomes excessive and 1 μF external capacitors are required.

Output Stage/Load Driving

The ICL7650/ICL7653 somewhat resemble a transconductance amplifier whose open-loop gain is proportional to load resistance. This behavior is apparent when loads are less than the high-impedance stage (approximately 18k Ω for one output circuit). The open-loop gain, for example, will be 17dB lower with a 1k Ω load than with a 10k Ω load. This lower gain is of little consequence if the amplifier is used strictly for DC since the DC gain is typically greater than 120dB, even with a 1k Ω load. For wideband applications, however, the best frequency response will be achieved with a load resistor of 10k Ω or higher. The result will be a smooth 6dB per octave response from 0.1Hz to 2MHz, with phase shifts of less than 10° in the transition region where the main amplifier takes over from the null amplifier.

Component Selection

CEXTA and CEXTB, the two required capacitors, have optimum values depending on the clock or chopping frequency. The correct value is 0.1 μF for the preset internal clock. When using an external clock, scale this component value in proportion to the relationship between the chopping frequency and the nulling time constant. A low-leakage ceramic capacitor may prove suitable for many applications; however, a high-quality film-type capacitor (such as mylar) is preferred. For lowest settling time at initial turn-on, use capacitors with low dielectric absorption (such as polypropylene types). With low-dielectric-absorption capacitors, the ICL7650/ICL7653 will settle to 1 μV offset in 100ms, but several seconds may be required if ceramic capacitors are used.

Thermoelectric Effects

Thermoelectric effects developed in thermocouple junctions of dissimilar materials (metals, alloys, silicon, etc.) ultimately limit precision DC measurements. Unless all junctions are at the same temperature, thermoelectric voltages (typically around 10 $\mu V/^\circ C$, but up to hundreds of $\mu V/^\circ C$ for some materials) will be generated. In order to realize the extremely low offset voltages that the chopper amplifier can provide, take special precautions to avoid temperature gradients. To eliminate air movement, enclose all components (particularly those caused by power-dissipating elements in the system). Minimize power-supply voltages and power dissipation, and use low-thermoelectric-coefficient connections where possible. It is advisable to separate the device surrounding heat-dissipating elements, and to use high-impedance loads.

Chopper-Stabilized Op Amps

Input Guarding

Low-leakage, high-impedance CMOS inputs allow the ICL7650/ICL7653 to measure high-impedance sources. Stray leakage paths can decrease input resistance and increase input currents unless inputs are guarded. Boards must be thoroughly cleaned with TCE or alcohol and blown dry with compressed air. The board should be coated with epoxy or silicone after cleaning to prevent contamination.

Leakage currents may cause trouble even with properly cleaned and coated boards, particularly since the input pins are adjacent to pins that are at supply potentials. Leakage can be significantly reduced by using guard-

ing to decrease the voltage difference between inputs and adjacent metal runs. Use a 10-lead pin circle, with the leads of the device formed so that the holes adjacent to the inputs are empty when it is inserted in the board to accomplish input guarding of the 8-pin TO-99 package. A conductive ring surrounding the inputs, the "guard," is connected to a low-impedance point that is approximately the same voltage as the inputs. The guard then absorbs the leakage current from the high-voltage pins. Typical guard connections are shown in Figure 3.

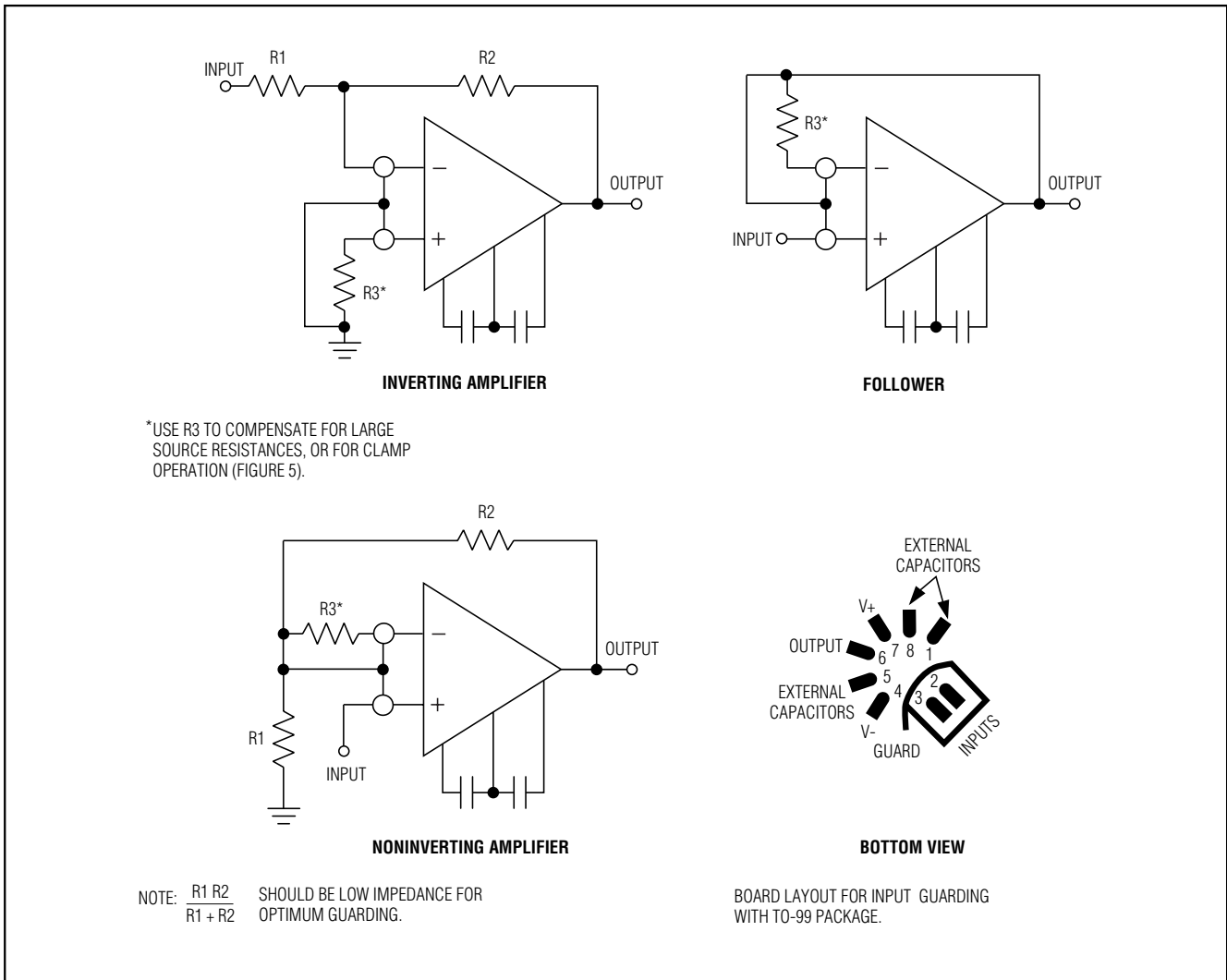

Figure 3. Input Guard Connection

Chopper-Stabilized Op Amps

The 14-pin DIP configuration has been specifically designed to ease input guarding. The pins adjacent to the inputs are not used.

Pin Compatibility

The ICL7653's pinout generally corresponds to that of industry-standard 8-pin devices such as the LM741 or LM101. However, its external null storage capacitors are connected to pins 1 and 8; whereas most op amps leave these pins open or use them for offset null or compensation capacitors.

The OP05 and OP07 op amps can be converted for ICL7650/ICL7653 operation. This can be accomplished by removing the offset null potentiometer, which is connected from pins 1 and 8 to V_+ , and replacing it with two capacitors connected from pins 1 and 8 to V_- . For LM108 devices, the compensation capacitor is replaced by the external nulling capacitors. Pin 5 is the output clamp connection on the ICL7650/ICL7653. By removing any circuit connections from this pin, the LM101/LM748/LM709 devices can undergo a similar conversion.

Typical Applications

Figure 4 shows the ICL7650/ICL7653 automatically nulling the offset voltage of a high-speed amplifier. The ICL7650/ICL7653 continuously monitor the voltage at

the amplifier's inverting input, integrate the error, and drive the amplifier's noninverting input to correct for the offset voltage detected at the inverting input. The circuit's DC offset characteristics are determined by the ICL7650/ICL7653, and its AC performance is determined by the high-speed amplifier. While this circuit continuously and automatically adjusts the amplifier's offset to less than $5\mu\text{V}$, it does not correct for errors caused by the input bias current, so the value of resistor R_F should be as low as is practical. This technique can be used with any op amp that is configured as an inverting amplifier.

Figures 5 and 6 illustrate basic inverting and noninverting amplifier circuits. Both figures show an output clamping circuit being used to enhance overload recovery performance. Supply voltage ($\pm 8\text{V}$ max) and output drive capability ($10\text{k}\Omega$ load for full swing) are the only limitations to consider when replacing other op amps with the ICL7650/ICL7653. Use a simple booster circuit to overcome these limitations (Figure 7). This enables the full output capabilities of the LM118 (or any other standard device) to be combined with the input capabilities of the ICL7650/ICL7653. Observe the loop gain stability carefully when the feedback network is added, particularly when a slower amplifier such as the LM741 is used.

A lower voltage supply is required when mixing the ICL7650/ICL7653 with circuits that operate at $\pm 15\text{V}$ supplies. One approach is to use a highly efficient voltage divider. This is illustrated in Figure 8, where the ICL7660 voltage converter is used to convert $+15\text{V}$ to $+7.5\text{V}$.

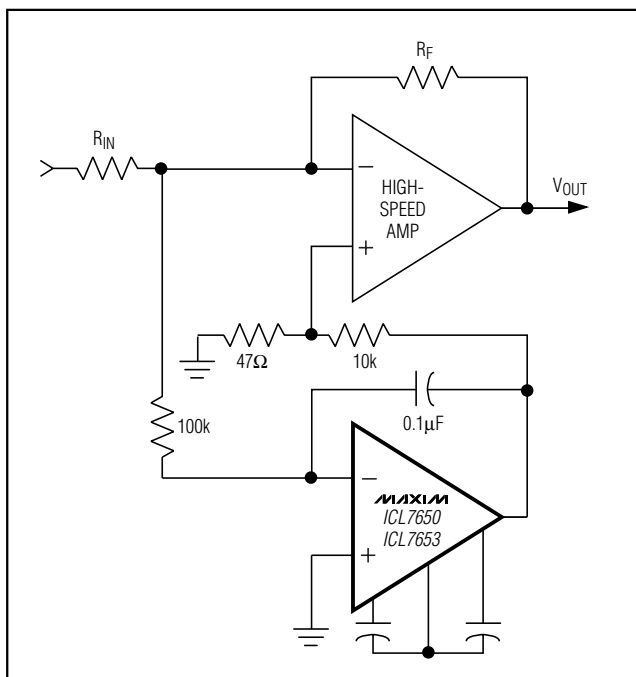

Figure 4. Nulling a High-Speed Amplifier

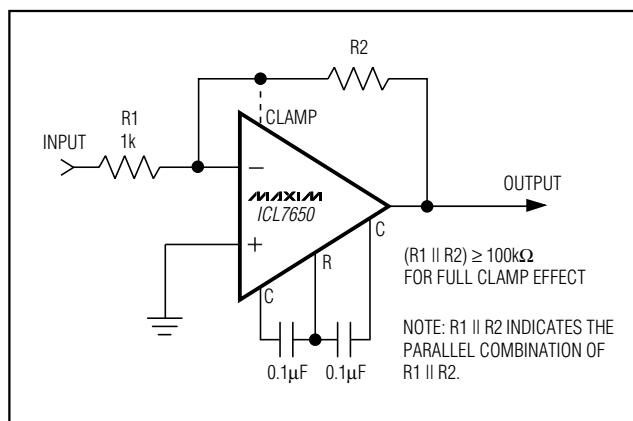

Figure 5. Inverting Amplifier with Optional Clamp

Chopper-Stabilized Op Amps



Figure 6. Noninverting Amplifier with Optional Clamp

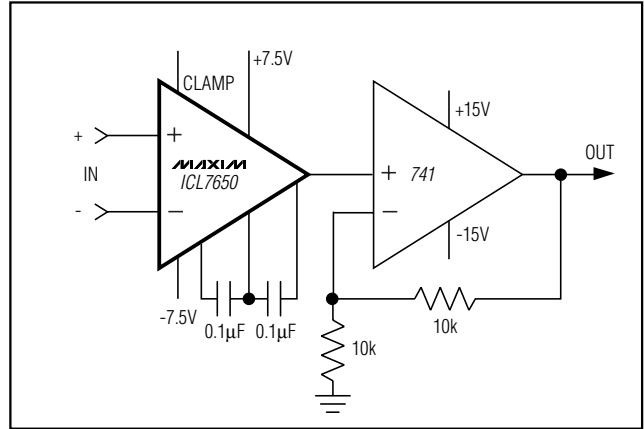

Figure 7. Using an Industry-Standard 741 to Boost Output Drive Capability

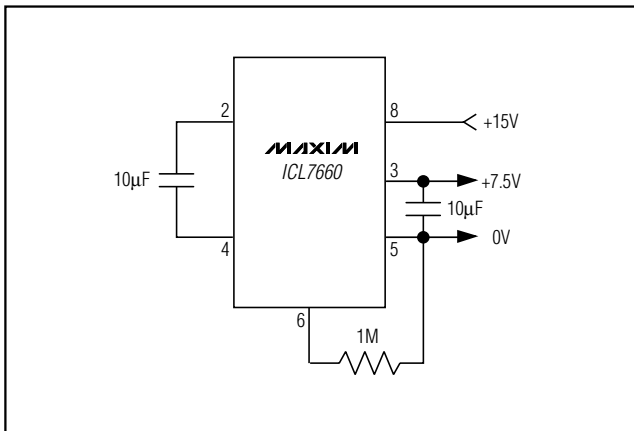
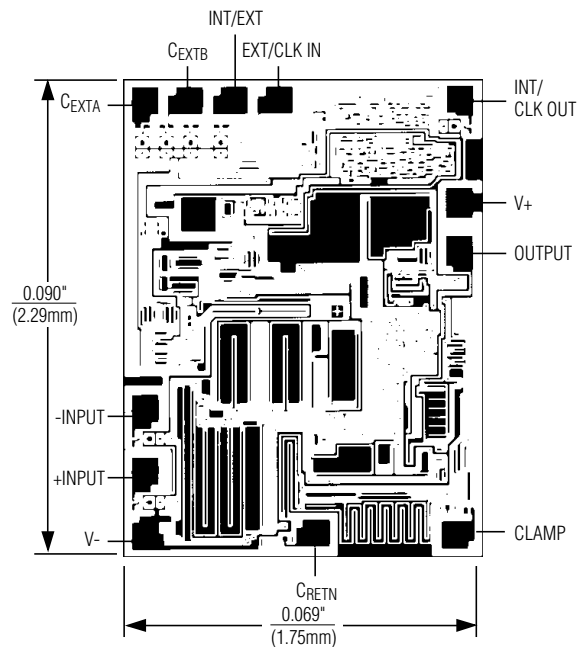

Figure 8. Splitting +15V with an ICL7660, 95% Efficiency (Same for -15V)

Chip Topography



Chopper-Stabilized Op Amps

Pin Configurations

ICL7650/ICL7650B/ICL7653/ICL7653B

TOP VIEW

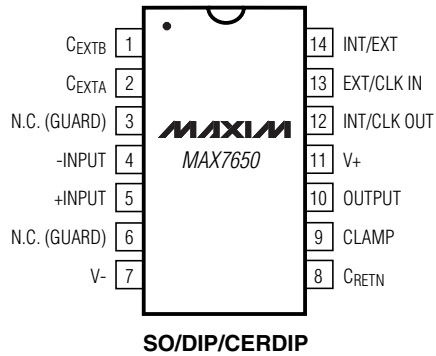

N.C. = NO INTERNAL CONNECTION

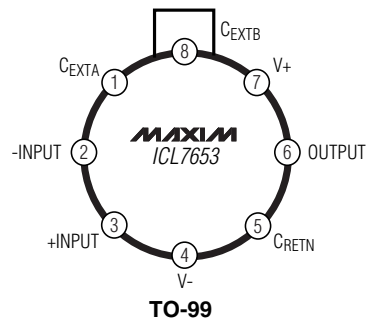
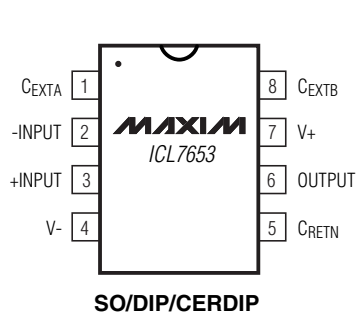
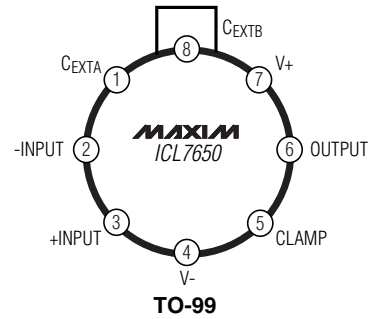
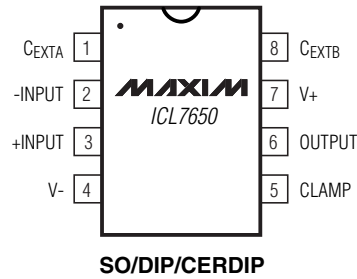

Chopper-Stabilized Op Amps

Package Information

ICL7650/ICL7650B/ICL7653/ICL7653B

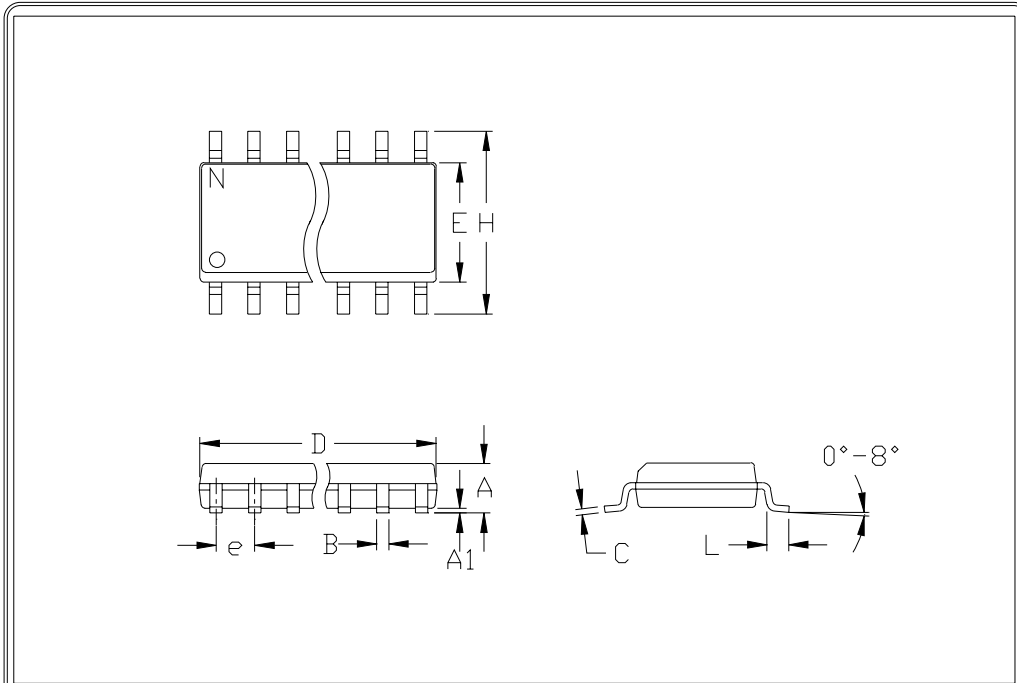

	INCHES		MILLIMETERS	
	MIN	MAX	MIN	MAX
A	0.053	0.069	1.35	1.75
A1	0.004	0.010	0.10	0.25
B	0.014	0.019	0.35	0.49
C	0.007	0.010	0.19	0.25
e	0.050		1.27	
E	0.150	0.157	3.80	4.00
H	0.228	0.244	5.80	6.20
h	0.010	0.020	0.25	0.50
L	0.016	0.050	0.40	1.27

	INCHES		MILLIMETERS		N	MS012
	MIN	MAX	MIN	MAX		
D	0.189	0.197	4.80	5.00	8	A
D	0.337	0.344	8.55	8.75	14	B
D	0.386	0.394	9.80	10.00	16	C

NOTES:

1. D&E DO NOT INCLUDE MOLD FLASH
2. MOLD FLASH OR PROTRUSIONS NOT TO EXCEED .15mm (.006")
3. LEADS TO BE COPLANAR WITHIN .102mm (.004")
4. CONTROLLING DIMENSION: MILLIMETER
5. MEETS JEDEC MS012-XX AS SHOWN IN ABOVE TABLE
6. N = NUMBER OF PINS



PACKAGE FAMILY OUTLINE: SOIC .150"

1/1

21-0041 A
DOCUMENT CONTROL NUMBER REV

Maxim cannot assume responsibility for use of any circuitry other than circuitry entirely embodied in a Maxim product. No circuit patent licenses are implied. Maxim reserves the right to change the circuitry and specifications without notice at any time.

12 _____ **Maxim Integrated Products, 120 San Gabriel Drive, Sunnyvale, CA 94086 408-737-7600**