



Chipsmall Limited consists of a professional team with an average of over 10 year of expertise in the distribution of electronic components. Based in Hongkong, we have already established firm and mutual-benefit business relationships with customers from,Europe,America and south Asia,supplying obsolete and hard-to-find components to meet their specific needs.

With the principle of “Quality Parts,Customers Priority,Honest Operation,and Considerate Service”,our business mainly focus on the distribution of electronic components. Line cards we deal with include Microchip,ALPS,ROHM,Xilinx,Pulse,ON,Everlight and Freescale. Main products comprise IC,Modules,Potentiometer,IC Socket,Relay,Connector.Our parts cover such applications as commercial,industrial, and automotives areas.

We are looking forward to setting up business relationship with you and hope to provide you with the best service and solution. Let us make a better world for our industry!



Contact us

Tel: +86-755-8981 8866 Fax: +86-755-8427 6832

Email & Skype: info@chipsmall.com Web: www.chipsmall.com

Address: A1208, Overseas Decoration Building, #122 Zhenhua RD., Futian, Shenzhen, China



World's Lowest Power 9-Axis MEMS MotionTracking™ Device

GENERAL DESCRIPTION

The ICM-20948 is the world's lowest power 9-axis MotionTracking device that is ideally suited for Smartphones, Tablets, Wearable Sensors, and IoT applications.

- 3-axis gyroscope, 3-axis accelerometer, 3-axis compass, and a Digital Motion Processor™ (DMP™) in a 3 mm x 3 mm x 1 mm (24-pin QFN) package
- DMP offloads computation of motion processing algorithms from the host processor, improving system power performance
- Software drivers are fully compliant with Google's latest Android release
- EIS FSYNC support

ICM-20948 supports an auxiliary I²C interface to external sensors, on-chip 16-bit ADCs, programmable digital filters, an embedded temperature sensor, and programmable interrupts. The device features an operating voltage range down to 1.71V. Communication ports include I²C and high speed SPI at 7 MHz.

Note: ICM-20948 VDDIO range is 1.71V to 1.95V, different than the MPU-9250 9-axis device.

ORDERING INFORMATION

PART	TEMP RANGE	PACKAGE
ICM-20948†	-40°C to +85°C	24-Pin QFN

†Denotes RoHS and Green-Compliant Package

BLOCK DIAGRAM



APPLICATIONS

- Smartphones and Tablets
- Wearable Sensors
- IoT Applications

FEATURES

- Lowest Power 9-Axis Device at 2.5 mW
- 3-Axis Gyroscope with Programmable FSR of ±250 dps, ±500 dps, ±1000 dps, and ±2000 dps
- 3-Axis Accelerometer with Programmable FSR of ±2g, ±4g, ±8g, and ±16g
- 3-Axis Compass with a wide range to ±4900 μT
- Onboard Digital Motion Processor (DMP)
- Android support
- Auxiliary I²C interface for external sensors
- On-Chip 16-bit ADCs and Programmable Filters
- 7 MHz SPI or 400 kHz Fast Mode I²C
- Digital-output temperature sensor
- VDD operating range of 1.71V to 3.6V
- MEMS structure hermetically sealed and bonded at wafer level
- RoHS and Green compliant

TYPICAL OPERATING CIRCUIT

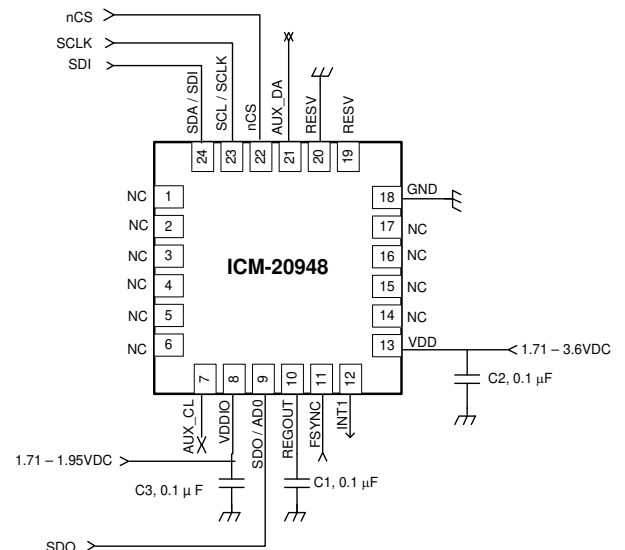

TABLE OF CONTENTS

GENERAL DESCRIPTION	1
ORDERING INFORMATION	1
BLOCK DIAGRAM	1
APPLICATIONS.....	1
FEATURES	1
TYPICAL OPERATING CIRCUIT	1
1 GENERAL DESCRIPTION	9
1.1 PURPOSE AND SCOPE	9
1.2 PRODUCT OVERVIEW	9
1.3 APPLICATIONS.....	9
2 FEATURES	10
2.1 GYROSCOPE FEATURES	10
2.2 ACCELEROMETER FEATURES.....	10
2.3 MAGNETOMETER FEATURES	10
2.4 DMP FEATURES.....	10
2.5 ADDITIONAL FEATURES.....	10
3 ELECTRICAL CHARACTERISTICS	11
3.1 GYROSCOPE SPECIFICATIONS.....	11
3.2 ACCELEROMETER SPECIFICATIONS.....	12
3.3 MAGNETOMETER SPECIFICATIONS	13
3.4 ELECTRICAL SPECIFICATIONS.....	13
<i>D.C. Electrical Characteristics</i>	13
<i>A.C. Electrical Characteristics</i>	14
<i>Other Electrical Specifications</i>	15
3.5 I ² C TIMING CHARACTERIZATION	16
3.6 SPI TIMING CHARACTERIZATION.....	17
3.7 ABSOLUTE MAXIMUM RATINGS	18
4 APPLICATIONS INFORMATION	19
4.1 PIN OUT DIAGRAM AND SIGNAL DESCRIPTION	19
4.2 TYPICAL OPERATING CIRCUIT	20
4.3 BILL OF MATERIALS FOR EXTERNAL COMPONENTS	20
4.4 EXPOSED DIE PAD PRECAUTIONS	20
4.5 BLOCK DIAGRAM	21
4.6 OVERVIEW	21
4.7 THREE-AXIS MEMS GYROSCOPE WITH 16-BIT ADCS AND SIGNAL CONDITIONING	22
4.8 THREE-AXIS MEMS ACCELEROMETER WITH 16-BIT ADCS AND SIGNAL CONDITIONING.....	22
4.9 THREE-AXIS MEMS MAGNETOMETER WITH 16-BIT ADCS AND SIGNAL CONDITIONING	22
4.10 DIGITAL MOTION PROCESSOR.....	22
4.11 PRIMARY I ² C AND SPI SERIAL COMMUNICATIONS INTERFACES	22
<i>ICM-20948 Solution Using I²C Interface</i>	22
<i>ICM-20948 Solution Using SPI Interface</i>	23
4.12 AUXILIARY I ² C SERIAL INTERFACE.....	24
4.13 SELF-TEST	24
4.14 CLOCKING	25
4.15 SENSOR DATA REGISTERS.....	25

4.16	FIFO.....	25
4.17	FSYNC.....	25
4.18	INTERRUPTS.....	25
4.19	DIGITAL-OUTPUT TEMPERATURE SENSOR.....	26
4.20	BIAS AND LDOS	26
4.21	CHARGE PUMP.....	26
4.22	POWER MODES.....	26
5	PROGRAMMABLE INTERRUPTS.....	27
6	DIGITAL INTERFACE.....	28
6.1	I ² C AND SPI SERIAL INTERFACES	28
6.2	I ² C INTERFACE	28
6.3	I ² C COMMUNICATIONS PROTOCOL	28
6.4	I ² C TERMS	30
6.5	SPI INTERFACE.....	31
7	REGISTER MAP FOR GYROSCOPE AND ACCELEROMETER	32
7.1	USER BANK 0 REGISTER MAP	32
7.2	USER BANK 1 REGISTER MAP	33
7.3	USER BANK 2 REGISTER MAP	34
7.4	USER BANK 3 REGISTER MAP	34
8	USER BANK 0 REGISTER DESCRIPTIONS.....	36
8.1	WHO_AM_I.....	36
8.2	USER_CTRL.....	36
8.3	LP_CONFIG.....	37
8.4	PWR_MGMT_1.....	37
8.5	PWR_MGMT_2.....	38
8.6	INT_PIN_CFG	38
8.7	INT_ENABLE	39
8.8	INT_ENABLE_1.....	39
8.9	INT_ENABLE_2.....	39
8.10	INT_ENABLE_3.....	40
8.11	I2C_MST_STATUS	40
8.12	INT_STATUS	40
8.13	INT_STATUS_1	41
8.14	INT_STATUS_2	41
8.15	INT_STATUS_3	41
8.16	DELAY_TIMEH	41
8.17	DELAY_TIMEL.....	42
8.18	ACCEL_XOUT_H	42
8.19	ACCEL_XOUT_L.....	42
8.20	ACCEL_YOUT_H	42
8.21	ACCEL_YOUT_L.....	43
8.22	ACCEL_ZOUT_H	43
8.23	ACCEL_ZOUT_L.....	43
8.24	GYRO_XOUT_H.....	43
8.25	GYRO_XOUT_L.....	44
8.26	GYRO_YOUT_H.....	44
8.27	GYRO_YOUT_L.....	44
8.28	GYRO_ZOUT_H.....	44

8.29	GYRO_ZOUT_L	45
8.30	TEMP_OUT_H	45
8.31	TEMP_OUT_L	45
8.32	EXT_SLV_SENS_DATA_00	45
8.33	EXT_SLV_SENS_DATA_01	46
8.34	EXT_SLV_SENS_DATA_02	46
8.35	EXT_SLV_SENS_DATA_03	46
8.36	EXT_SLV_SENS_DATA_04	46
8.37	EXT_SLV_SENS_DATA_05	47
8.38	EXT_SLV_SENS_DATA_06	47
8.39	EXT_SLV_SENS_DATA_07	47
8.40	EXT_SLV_SENS_DATA_08	47
8.41	EXT_SLV_SENS_DATA_09	48
8.42	EXT_SLV_SENS_DATA_10	48
8.43	EXT_SLV_SENS_DATA_11	48
8.44	EXT_SLV_SENS_DATA_12	48
8.45	EXT_SLV_SENS_DATA_13	49
8.46	EXT_SLV_SENS_DATA_14	49
8.47	EXT_SLV_SENS_DATA_15	49
8.48	EXT_SLV_SENS_DATA_16	49
8.49	EXT_SLV_SENS_DATA_17	50
8.50	EXT_SLV_SENS_DATA_18	50
8.51	EXT_SLV_SENS_DATA_19	50
8.52	EXT_SLV_SENS_DATA_20	50
8.53	EXT_SLV_SENS_DATA_21	51
8.54	EXT_SLV_SENS_DATA_22	51
8.55	EXT_SLV_SENS_DATA_23	51
8.56	FIFO_EN_1	52
8.57	FIFO_EN_2	52
8.58	FIFO_RST	53
8.59	FIFO_MODE	53
8.60	FIFO_COUNTH	53
8.61	FIFO_COUNTL	53
8.62	FIFO_R_W	54
8.63	DATA_RDY_STATUS	54
8.64	FIFO_CFG	54
8.65	REG_BANK_SEL	54
9	USR BANK 1 REGISTER DESCRIPTIONS.....	55
9.1	SELF_TEST_X_GYRO	55
9.2	SELF_TEST_Y_GYRO	55
9.3	SELF_TEST_Z_GYRO	55
9.4	SELF_TEST_X_ACCEL	55
9.5	SELF_TEST_Y_ACCEL	56
9.6	SELF_TEST_Z_ACCEL	56
9.7	XA_OFFS_H	56
9.8	XA_OFFS_L	56
9.9	YA_OFFS_H	56
9.10	YA_OFFS_L	57
9.11	ZA_OFFS_H	57
9.12	ZA_OFFS_L	57

9.13	TIMEBASE_CORRECTION_PLL.....	57
9.14	REG_BANK_SEL.....	58
10	USR BANK 2 REGISTER MAP	59
10.1	GYRO_SmplRT_DIV.....	59
10.2	GYRO_CONFIG_1.....	59
10.3	GYRO_CONFIG_2.....	60
10.4	XG_OFFS_USRH.....	61
10.5	XG_OFFS_USRL.....	62
10.6	YG_OFFS_USRH.....	62
10.7	YG_OFFS_USRL.....	62
10.8	ZG_OFFS_USRH.....	62
10.9	ZG_OFFS_USRL.....	62
10.10	ODR_ALIGN_EN.....	63
10.11	ACCEL_SmplRT_DIV_1.....	63
10.12	ACCEL_SmplRT_DIV_2.....	63
10.13	ACCEL_INTEL_CTRL.....	63
10.14	ACCEL_WOM_THR.....	64
10.15	ACCEL_CONFIG.....	64
10.16	ACCEL_CONFIG_2.....	65
10.17	FSYNC_CONFIG.....	66
10.18	TEMP_CONFIG.....	67
10.19	MOD_CTRL_USR.....	67
10.20	REG_BANK_SEL.....	67
11	USR BANK 3 REGISTER MAP	68
11.1	I2C_MST_ODR_CONFIG.....	68
11.2	I2C_MST_CTRL.....	68
11.3	I2C_MST_DELAY_CTRL.....	69
11.4	I2C_SLV0_ADDR.....	69
11.5	I2C_SLV0_REG.....	69
11.6	I2C_SLV0_CTRL.....	70
11.7	I2C_SLV0_DO.....	70
11.8	I2C_SLV1_ADDR.....	70
11.9	I2C_SLV1_REG.....	71
11.10	I2C_SLV1_CTRL.....	71
11.11	I2C_SLV1_DO.....	72
11.12	I2C_SLV2_ADDR.....	72
11.13	I2C_SLV2_REG.....	72
11.14	I2C_SLV2_CTRL.....	73
11.15	I2C_SLV2_DO.....	73
11.16	I2C_SLV3_ADDR.....	73
11.17	I2C_SLV3_REG.....	74
11.18	I2C_SLV3_CTRL.....	74
11.19	I2C_SLV3_DO.....	74
11.20	I2C_SLV4_ADDR.....	75
11.21	I2C_SLV4_REG.....	75
11.22	I2C_SLV4_CTRL.....	75
11.23	I2C_SLV4_DO.....	75
11.24	I2C_SLV4_DI.....	76
11.25	REG_BANK_SEL.....	76

12	REGISTER MAP FOR MAGNETOMETER	77
12.1	REGISTER MAP DESCRIPTION	77
13	DETAILED DESCRIPTIONS FOR MAGNETOMETER REGISTERS	78
13.1	WIA: DEVICE ID	78
13.2	ST1: STATUS 1	78
13.3	HXL TO HZH: MEASUREMENT DATA	78
13.4	ST2: STATUS 2	79
13.5	CNTL2: CONTROL 2	79
13.6	CNTL3: CONTROL 3	80
13.7	TS1, TS2: TEST 1, 2	80
14	USE NOTES	81
14.1	GYROSCOPE MODE TRANSITION	81
14.2	POWER MANAGEMENT 1 REGISTER SETTING	81
14.3	DMP MEMORY ACCESS	81
14.4	TIME BASE CORRECTION	81
14.5	I ² C MASTER CLOCK FREQUENCY	81
14.6	CLOCKING	82
14.7	LP_EN BIT-FIELD USAGE	82
14.8	REGISTER ACCESS USING SPI INTERFACE	82
15	ORIENTATION OF AXES	83
16	PACKAGE DIMENSIONS	84
17	PART NUMBER PART MARKINGS.....	86
18	REFERENCES	87
19	DOCUMENT INFORMATION	88
19.1	REVISION HISTORY	88
	COMPLIANCE DECLARATION DISCLAIMER	89

LIST OF FIGURES

Figure 1. I²C Bus Timing Diagram..... 16

Figure 2. SPI Bus Timing Diagram 17

Figure 3. Pin out Diagram for ICM-20948 3 mm x 3 mm x 1 mm QFN 19

Figure 4. ICM-20948 Application Schematic (a) I²C operation (b) SPI operation 20

Figure 5. ICM-20948 Block Diagram 21

Figure 6. ICM-20948 Solution Using I²C Interface 23

Figure 7. ICM-20948 Solution Using SPI Interface 24

Figure 8. START and STOP Conditions 28

Figure 9. Acknowledge on the I²C Bus 29

Figure 10. Complete I²C Data Transfer 29

Figure 11. Typical SPI Master / Slave Configuration 31

Figure 12. Orientation of Axes of Sensitivity and Polarity of Rotation 83

Figure 13. Orientation of Axes of Sensitivity for Magnetometer 83

Figure 14. Package Dimensions 84

Figure 15. Part Number Part Markings..... 86

LIST OF TABLES

Table 1. Gyroscope Specifications	11
Table 2. Accelerometer Specifications	12
Table 3. Magnetometer Specifications.....	13
Table 4. D.C. Electrical Characteristics.....	13
Table 5. A.C. Electrical Characteristics.....	15
Table 6. Other Electrical Specifications	15
Table 7. I ² C Timing Characteristics	16
Table 8. SPI Timing Characteristics (7 MHz)	17
Table 9. Absolute Maximum Ratings	18
Table 10. Signal Descriptions.....	19
Table 11. Bill of Materials	20
Table 12. Power Modes for ICM-20948.....	26
Table 13. Interrupt Sources	27
Table 14. Serial Interface	28
Table 15. I ² C Terms	30
Table 16. Gyroscope Configuration 1	60
Table 17. Gyroscope Configuration 2	61
Table 18. Accelerator Configuration.....	64
Table 19. Accelerator Configuration 2.....	66
Table 20. Register Table for Magnetometer	77
Table 21. Register Map for Magnetometer	77
Table 22. Magnetometer Measurement Data Format	79
Table 23. I ² C Master Clock Frequency	82
Table 24. Package Dimensions	85
Table 26. Part Number Part Markings	86

1 GENERAL DESCRIPTION

1.1 PURPOSE AND SCOPE

This document is a preliminary data sheet, providing a description, specifications, and design related information on the ICM-20948 MotionTracking device.

For references to register map and descriptions of individual registers, please refer to the ICM-20948 Register Map and Register Descriptions document.

1.2 PRODUCT OVERVIEW

The ICM-20948 is a multi-chip module (MCM) consisting of two dies integrated into a single QFN package. One die houses a 3-axis gyroscope, a 3-axis accelerometer, and a Digital Motion Processor™ (DMP). The other die houses the AK09916 3-axis magnetometer from Asahi Kasei Microdevices Corporation. The ICM-20948 is a 9-axis MotionTracking device all in a small 3x3x1mm QFN package. The device supports the following features:

- FIFO of size 512 bytes (FIFO size will vary depending on DMP feature-set)
- Runtime Calibration
- Enhanced FSYNC functionality to improve timing for applications like EIS

ICM-20948 devices, with their 9-axis integration, on-chip DMP, and run-time calibration firmware, enable manufacturers to eliminate the costly and complex selection, qualification, and system level integration of discrete devices, guaranteeing optimal motion performance for consumers.

The gyroscope has a programmable full-scale range of ± 250 dps, ± 500 dps, ± 1000 dps, and ± 2000 dps. The accelerometer has a user-programmable accelerometer full-scale range of $\pm 2g$, $\pm 4g$, $\pm 8g$, and $\pm 16g$. Factory-calibrated initial sensitivity of both sensors reduces production-line calibration requirements.

Other key features include on-chip 16-bit ADCs, programmable digital filters, an embedded temperature sensor, and programmable interrupts. The device features I²C and SPI serial interfaces, a VDD operating range of 1.71V to 3.6V, and a separate digital IO supply, VDDIO from 1.71V to 1.95V.

Communication with all registers of the device is performed using I²C at up to 100 kHz (standard-mode) or up to 400 kHz (fast-mode), or SPI at up to 7 MHz.

By leveraging its patented and volume-proven CMOS-MEMS fabrication platform, which integrates MEMS wafers with companion CMOS electronics through wafer-level bonding, InvenSense has driven the package size down to a footprint and thickness of 3 mm x 3 mm x 1 mm (24-pin QFN), to provide a very small yet high-performance, low-cost package. The device provides high robustness by supporting 20,000g shock reliability.

1.3 APPLICATIONS

- Smartphones and Tablets
- Wearable Sensors
- IoT Applications
- Drones

2 FEATURES

2.1 GYROSCOPE FEATURES

The triple-axis MEMS gyroscope in the ICM-20948 includes the following features:

- Digital-output X-, Y-, and Z-axis angular rate sensors (gyroscopes) with a user-programmable full-scale range of ± 250 dps, ± 500 dps, ± 1000 dps, and ± 2000 dps, and integrated 16-bit ADCs
- User-selectable ODR; User-selectable low pass filters
- Self-test

2.2 ACCELEROMETER FEATURES

The triple-axis MEMS accelerometer in ICM-20948 includes the following features:

- Digital-output X-, Y-, and Z-axis accelerometer with a programmable full scale range of $\pm 2g$, $\pm 4g$, $\pm 8g$, and $\pm 16g$, and integrated 16-bit ADCs
- User-selectable ODR; User-selectable low pass filters
- Wake-on-motion interrupt for low power operation of applications processor
- Self-test

2.3 MAGNETOMETER FEATURES

The triple-axis MEMS magnetometer in ICM-20948 includes a wide range of features:

- 3-axis silicon monolithic Hall-effect magnetic sensor with magnetic concentrator
- Wide dynamic measurement range and high resolution with lower current consumption.
- Output data resolution of 16-bits
- Full scale measurement range is $\pm 4900 \mu T$
- Self-test function with internal magnetic source to confirm magnetic sensor operation on end products

2.4 DMP FEATURES

The DMP in ICM-20948 includes the following capabilities:

- Offloads computation of motion processing algorithms from the host processor. The DMP can be used to minimize power, simplify timing, simplify the software architecture, and save valuable MIPS on the host processor for use in applications.
- The DMP enables ultra-low power run-time and background calibration of the accelerometer, gyroscope, and compass, maintaining optimal performance of the sensor data for both physical and virtual sensors generated through sensor fusion. This enables the best user experience for all sensor enabled applications for the lifetime of the device.
- DMP features simplify the software architecture resulting in quicker time to market.
- DMP features are OS, Platform, and Architecture independent, supporting virtually any AP, MCU, or other embedded architecture.

2.5 ADDITIONAL FEATURES

The ICM-20948 includes the following additional features:

- I²C at up to 100 kHz (standard-mode) or up to 400 kHz (fast-mode) or SPI at up to 7 MHz for communication with registers
- Auxiliary master I²C bus for reading data from external sensors (e.g. magnetometer)
- Digital-output temperature sensor
- 20,000g shock tolerant
- MEMS structure hermetically sealed and bonded at wafer level
- RoHS and Green compliant

3 ELECTRICAL CHARACTERISTICS

3.1 GYROSCOPE SPECIFICATIONS

Typical Operating Circuit of section 4.2, VDD = 1.8V, VDDIO = 1.8V, T_A=25°C, unless otherwise noted.

NOTE: All specifications apply to Low-Power Mode and Low-Noise Mode, unless noted otherwise

PARAMETER	CONDITIONS	MIN	TYP	MAX	UNITS	NOTES
GYROSCOPE SENSITIVITY						
Full-Scale Range	GYRO_FS_SEL=0		±250		dps	1
	GYRO_FS_SEL=1		±500		dps	1
	GYRO_FS_SEL=2		±1000		dps	1
	GYRO_FS_SEL=3		±2000		dps	1
Gyroscope ADC Word Length			16		bits	1
Sensitivity Scale Factor	GYRO_FS_SEL=0		131		LSB/(dps)	1
	GYRO_FS_SEL=1		65.5		LSB/(dps)	1
	GYRO_FS_SEL=2		32.8		LSB/(dps)	1
	GYRO_FS_SEL=3		16.4		LSB/(dps)	1
Sensitivity Scale Factor Tolerance	25°C		±1.5		%	2
Sensitivity Scale Factor Variation Over Temperature	-40°C to +85°C		±3		%	2
Nonlinearity	Best fit straight line; 25°C		±0.1		%	2, 3
Cross-Axis Sensitivity			±2		%	2, 3
ZERO-RATE OUTPUT (ZRO)						
Initial ZRO Tolerance	25°C (Component-level)		±5		dps	2
ZRO Variation Over Temperature	-40°C to +85°C		±0.05		dps/°C	2
GYROSCOPE NOISE PERFORMANCE (GYRO_FS_SEL=0)						
Noise Spectral Density	Based on Noise Bandwidth = 10 Hz		0.015		dps/√Hz	2
GYROSCOPE MECHANICAL FREQUENCIES		25	27	29	kHz	2
LOW PASS FILTER RESPONSE	Programmable Range	5.7		197	Hz	1, 3
GYROSCOPE START-UP TIME	From Full-Chip Sleep mode		35		ms	2, 3
OUTPUT DATA RATE	Low-Power Mode	4.4		562.5	Hz	1
	Low-Noise Mode GYRO_FCHOICE=1; GYRO_DLPFCFG=x	4.4		1.125k	Hz	
	Low-Noise Mode GYRO_FCHOICE=0; GYRO_DLPFCFG=x			9k	Hz	

Table 1. Gyroscope Specifications

NOTES:

1. Guaranteed by design.
2. Derived from validation or characterization of parts, not guaranteed in production.
3. Low-noise mode specification.

3.2 ACCELEROMETER SPECIFICATIONS

Typical Operating Circuit of section 4.2, VDD = 1.8V, VDDIO = 1.8V, T_A=25°C, unless otherwise noted.

NOTES: All specifications apply to Low-Power Mode and Low-Noise Mode, unless noted otherwise

PARAMETER	CONDITIONS	MIN	TYP	MAX	UNITS	NOTES
ACCELEROMETER SENSITIVITY						
Full-Scale Range	ACCEL_FS=0		±2		G	1
	ACCEL_FS=1		±4		G	1
	ACCEL_FS=2		±8		G	1
	ACCEL_FS=3		±16		G	1
ADC Word Length	Output in two's complement format		16		Bits	1
Sensitivity Scale Factor	ACCEL_FS=0		16,384		LSB/g	1
	ACCEL_FS=1		8,192		LSB/g	1
	ACCEL_FS=2		4,096		LSB/g	1
	ACCEL_FS=3		2,048		LSB/g	1
Initial Tolerance	Component-level		±0.5		%	2
Sensitivity Change vs. Temperature	-40°C to +85°C ACCEL_FS=0		±0.026		%/°C	2
Nonlinearity	Best Fit Straight Line		±0.5		%	2, 3
Cross-Axis Sensitivity			±2		%	2, 3
ZERO-G OUTPUT						
Initial Tolerance	Component-level, all axes		±25		mg	2
Initial Tolerance	Board-level, all axes		±50		mg	2
Zero-G Level Change vs. Temperature	0°C to +85°C		±0.80		mg/°C	2
ACCELEROMETER NOISE PERFORMANCE						
Noise Spectral Density	Based on Noise Bandwidth = 10 Hz		230		µg/√Hz	2
LOW PASS FILTER RESPONSE	Programmable Range	5.7		246	Hz	1, 3
ACCELEROMETER STARTUP TIME	From Sleep mode		20		ms	2, 3
	From Cold Start, 1 ms V _{DD} ramp		30		ms	2, 3
OUTPUT DATA RATE	Low-Power Mode	0.27		562.5	Hz	1
	Low-Noise Mode ACCEL_FCHOICE=1; ACCEL_DLPFCFG=x	4.5		1.125k	Hz	
	Low-Noise Mode ACCEL_FCHOICE=0; ACCEL_DLPFCFG=x			4.5k	Hz	

Table 2. Accelerometer Specifications

NOTES:

1. Guaranteed by design.
2. Derived from validation or characterization of parts, not guaranteed in production.
3. Low-noise mode specification.

3.3 MAGNETOMETER SPECIFICATIONS

Typical Operating Circuit of section 4.2, VDD = 1.8V, VDDIO = 1.8V, T_A=25°C, unless otherwise noted.

PARAMETER	CONDITIONS	MIN	TYP	MAX	UNITS	NOTES
MAGNETOMETER SENSITIVITY						
Full-Scale Range			±4900		μT	1
Output Resolution			16		bits	1
Sensitivity Scale Factor			0.15		μT / LSB	1
ZERO-FIELD OUTPUT						
Initial Calibration Tolerance		-2000		+2000	LSB	2
OTHER						
Output Data Rate				100	Hz	1

Table 3. Magnetometer Specifications

NOTES:

1. Guaranteed by design.
2. Derived from validation or characterization of parts, not guaranteed in production.

3.4 ELECTRICAL SPECIFICATIONS

D.C. Electrical Characteristics

Typical Operating Circuit of section 4.2, VDD = 1.8V, VDDIO = 1.8V, T_A=25°C, unless otherwise noted.

PARAMETER	CONDITIONS	MIN	TYP	MAX	UNITS	NOTES
SUPPLY VOLTAGES						
VDD		1.71	1.8	3.6	V	1
VDDIO		1.71	1.8	1.95	V	1
SUPPLY CURRENTS						
9-Axis (DMP disabled)	Low-Noise Mode; Compass in Continuous Mode		3.11		mA	2
Gyroscope Only (DMP, Barometer & Accelerometer disabled)	Low-Power Mode, 102.3 Hz update rate, 1x averaging filter		1.23		mA	2
Accelerometer Only (DMP, Barometer & Gyroscope disabled)	Low-Power Mode, 102.3 Hz update rate, 1x averaging filter		68.9		μA	2
Magnetometer Only (DMP, Accelerometer & Gyroscope disabled)	8 Hz update rate		90		μA	2
Full-Chip Sleep Mode			8		μA	2
TEMPERATURE RANGE						
Specified Temperature Range	Performance parameters are not applicable beyond Specified Temperature Range	-40		+85	°C	1

Table 4. D.C. Electrical Characteristics

NOTES:

1. Guaranteed by design.
2. Derived from validation or characterization of parts, not guaranteed in production.

A.C. Electrical Characteristics

Typical Operating Circuit of section 4.2, VDD = 1.8V, VDDIO = 1.8V, T_A=25°C, unless otherwise noted.

PARAMETER	CONDITIONS	MIN	TYP	MAX	UNITS	NOTES
SUPPLIES						
Supply Ramp Time (T _{RAMP})	Monotonic ramp. Ramp rate is 10% to 90% of the final value.	0.01	20	100	ms	1
TEMPERATURE SENSOR						
Operating Range	Ambient	-40		85	°C	1
Sensitivity	Untrimmed		333.87		LSB/°C	
Room Temp Offset	21°C		0		LSB	
POWER-ON RESET						
Supply Ramp Time (T _{RAMP})	Valid power-on RESET	0.01	20	100	ms	1
Start-up time for register read/write	From power-up		11	100	ms	1
I²C ADDRESS	AD0 = 0		1101000			
	AD0 = 1		1101001			
DIGITAL INPUTS (FSYNC, AD0, SCLK, SDI, CS)						
V _{IH} , High Level Input Voltage		0.7*VDDIO			V	1
V _{IL} , Low Level Input Voltage				0.3*VDDIO	V	
C _I , Input Capacitance			< 10		pF	
DIGITAL OUTPUT (SDO, INT)						
V _{OH} , High Level Output Voltage	R _{LOAD} =1 MΩ;	0.9*VDDIO			V	1
V _{OL1} , LOW-Level Output Voltage	R _{LOAD} =1 MΩ;			0.1*VDDIO	V	
V _{OLINT1} , INT Low-Level Output Voltage	OPEN=1, 0.3 mA sink Current			0.1	V	
Output Leakage Current	OPEN=1		100		nA	
t _{INT} , INT Pulse Width	LATCH_INT_EN=0		50		μs	
I²C I/O (SCL, SDA)						
V _{IL} , LOW Level Input Voltage		-0.5V		0.3*VDDIO	V	1
V _{IH} , HIGH-Level Input Voltage		0.7*VDDIO		VDDIO + 0.5V	V	
V _{hys} , Hysteresis			0.1*VDDIO		V	
V _{OL} , LOW-Level Output Voltage	3 mA sink current	0		0.4	V	
I _{OL} , LOW-Level Output Current	V _{OL} =0.4V		3		mA	
	V _{OL} =0.6V		6		mA	
Output Leakage Current			100		nA	
t _{of} , Output Fall Time from V _{IHmax} to V _{ILmax}	C _b bus capacitance in pF	20+0.1C _b		250	ns	
AUXILLIARY I/O (AUX_CL, AUX_DA)						
V _{IL} , LOW-Level Input Voltage		-0.5V		0.3*VDDIO	V	1
V _{IH} , HIGH-Level Input Voltage		0.7* VDDIO		VDDIO + 0.5V	V	
V _{hys} , Hysteresis			0.1* VDDIO		V	
V _{OL1} , LOW-Level Output Voltage	VDDIO > 2V; 1 mA sink current	0		0.4	V	
V _{OL3} , LOW-Level Output Voltage	VDDIO < 2V; 1 mA sink current	0		0.2* VDDIO	V	
I _{OL} , LOW-Level Output Current	V _{OL} = 0.4V		3		mA	
	V _{OL} = 0.6V		6		mA	
Output Leakage Current			100		nA	
t _{of} , Output Fall Time from V _{IHmax} to V _{ILmax}	C _b bus capacitance in pF	20+0.1C _b		250	ns	

PARAMETER	CONDITIONS	MIN	TYP	MAX	UNITS	NOTES
INTERNAL CLOCK SOURCE						
Clock Frequency Initial Tolerance	Accelerometer Only Mode	-5		+5	%	1
	Gyroscope or 6-Axis Mode WITHOUT Timebase Correction	-9		+9	%	1
	Gyroscope or 6-Axis Mode WITH Timebase Correction	-1		+1		
Frequency Variation over Temperature	Accelerometer Only Mode	-10		+10	%	1
	Gyroscope or 6-Axis Mode		±1		%	1

Table 5. A.C. Electrical Characteristics

NOTES:

1. Derived from validation or characterization of parts, not guaranteed in production.

Other Electrical Specifications

Typical Operating Circuit of section 4.2, VDD = 1.8V, VDDIO = 1.8V, T_A=25°C, unless otherwise noted.

PARAMETER	CONDITIONS	MIN	TYP	MAX	UNITS	NOTES
SERIAL INTERFACE						
SPI Operating Frequency, All Registers Read/Write	Low Speed Characterization		100 ±10%		kHz	
	High Speed Characterization		7 ±10%		MHz	
I ² C Operating Frequency	All registers, Fast-mode			400	kHz	
	All registers, Standard-mode			100	kHz	

Table 6. Other Electrical Specifications

NOTES:

1. Derived from validation or characterization of parts, not guaranteed in production.

3.5 I²C TIMING CHARACTERIZATION

Typical Operating Circuit of section 4.2, VDD = 1.8V, VDDIO = 1.8V, T_A=25°C, unless otherwise noted.

PARAMETERS	CONDITIONS	MIN	TYPICAL	MAX	UNITS	NOTES
I²C TIMING		I²C FAST-MODE				
f _{SCL} , SCL Clock Frequency				400	kHz	1, 2
t _{HD,STA} , (Repeated) START Condition Hold Time		0.6			μs	1, 2
t _{LOW} , SCL Low Period		1.3			μs	1, 2
t _{HIGH} , SCL High Period		0.6			μs	1, 2
t _{SU,STA} , Repeated START Condition Setup Time		0.6			μs	1, 2
t _{HD,DAT} , SDA Data Hold Time		0			μs	1, 2
t _{SU,DAT} , SDA Data Setup Time		100			ns	1, 2
t _r , SDA and SCL Rise Time	C _b bus cap. from 10 to 400 pF	20+0.1C _b		300	ns	1, 2
t _f , SDA and SCL Fall Time	C _b bus cap. from 10 to 400 pF	20+0.1C _b		300	ns	1, 2
t _{SU,STO} , STOP Condition Setup Time		0.6			μs	1, 2
t _{BUF} , Bus Free Time Between STOP and START Condition		1.3			μs	1, 2
C _b , Capacitive Load for each Bus Line			< 400		pF	1, 2
t _{VD,DAT} , Data Valid Time				0.9	μs	1, 2
t _{VD,ACK} , Data Valid Acknowledge Time				0.9	μs	1, 2

Table 7. I²C Timing Characteristics

NOTES:

1. Timing Characteristics apply to both Primary and Auxiliary I²C Bus.
2. Based on characterization of 5 parts over temperature and voltage as mounted on evaluation board or in sockets.

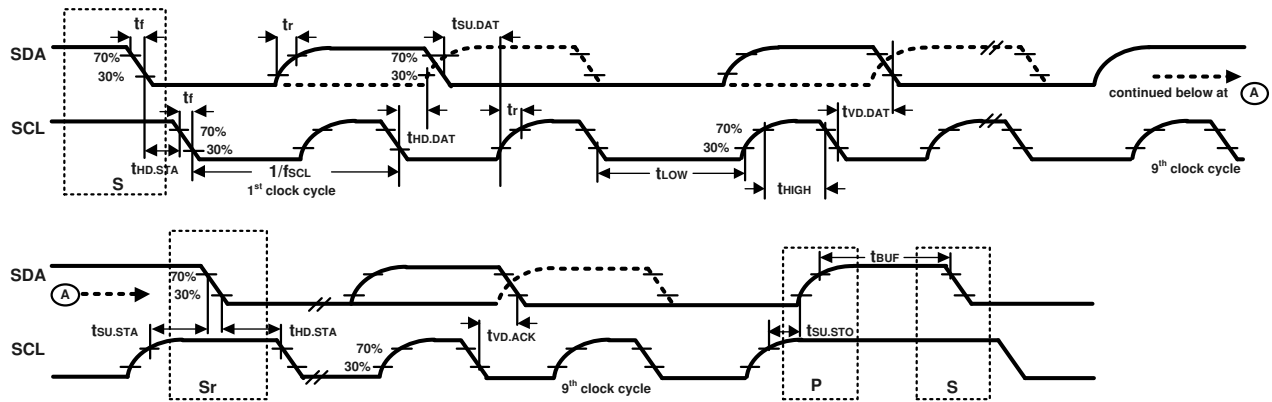

Figure 1. I²C Bus Timing Diagram

3.6 SPI TIMING CHARACTERIZATION

Typical Operating Circuit of section 4.2, VDD = 1.8V, VDDIO = 1.8V, T_A=25°C, unless otherwise noted.

PARAMETERS	CONDITIONS	MIN	TYPICAL	MAX	UNITS	NOTES
SPI TIMING						
f _{SCLK} , SCLK Clock Frequency				7	MHz	
t _{LOW} , SCLK Low Period		64			ns	
t _{HIGH} , SCLK High Period		64			ns	
t _{SU,CS} , CS Setup Time		8			ns	
t _{HD,CS} , CS Hold Time		500			ns	
t _{SU,SDI} , SDI Setup Time		5			ns	
t _{HD,SDI} , SDI Hold Time		7			ns	
t _{VD,SDO} , SDO Valid Time	C _{load} = 20 pF			59	ns	
t _{HD,SDO} , SDO Hold Time	C _{load} = 20 pF	6			ns	
t _{DIS,SDO} , SDO Output Disable Time				50	ns	

Table 8. SPI Timing Characteristics (7 MHz)

NOTES:

1. Based on characterization of 5 parts over temperature and voltage as mounted on evaluation board or in sockets

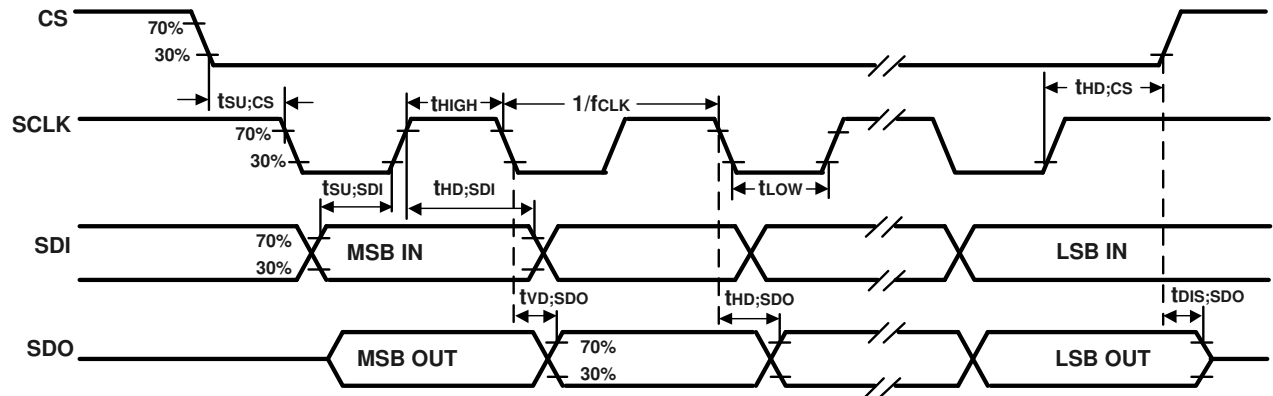

Figure 2. SPI Bus Timing Diagram

3.7 ABSOLUTE MAXIMUM RATINGS

Stress above those listed as “Absolute Maximum Ratings” may cause permanent damage to the device. These are stress ratings only and functional operation of the device at these conditions is not implied. Exposure to the absolute maximum ratings conditions for extended periods may affect device reliability.

PARAMETER	RATING
Supply Voltage, VDD	-0.5V to +4V
Supply Voltage, VDDIO	-0.3V to +2.5V
REGOUT	-0.5V to 2V
Input Voltage Level (AUX_DA, ADO, FSYNC, INT, SCL, SDA)	-0.5V to VDD + 0.5V
Acceleration (Any Axis, unpowered)	20,000g for 0.2 ms
Operating Temperature Range	-40°C to +105°C
Storage Temperature Range	-40°C to +125°C
Electrostatic Discharge (ESD) Protection	2kV (HBM); 200V (MM)
Latch-up	JEDEC Class II (2), 125°C ±100 mA

Table 9. Absolute Maximum Ratings

4 APPLICATIONS INFORMATION

4.1 PIN OUT DIAGRAM AND SIGNAL DESCRIPTION

PIN NUMBER	PIN NAME	PIN DESCRIPTION
7	AUX_CL	I ² C Master serial clock, for connecting to external sensors
8	VDDIO	Digital I/O supply voltage
9	AD0 / SDO	I ² C Slave Address LSB (AD0); SPI serial data output (SDO)
10	REGOUT	Regulator filter capacitor connection
11	FSYNC	Frame synchronization digital input. Connect to GND if unused
12	INT1	Interrupt 1
13	VDD	Power supply voltage
18	GND	Power supply ground
19	RESV	Reserved. Do not connect.
20	RESV	Reserved. Connect to GND.
21	AUX_DA	I ² C master serial data, for connecting to external sensors
22	nCS	Chip select (SPI mode only)
23	SCL / SCLK	I ² C serial clock (SCL); SPI serial clock (SCLK)
24	SDA / SDI	I ² C serial data (SDA); SPI serial data input (SDI)
1 – 6, 14 - 17	NC	Do not connect

Table 10. Signal Descriptions

NOTE: Power up with SCL/SCLK and nCS pins held low is not a supported use case. In case this power up approach is used, software reset is required using the PWR_MGMT_1 register, prior to initialization.

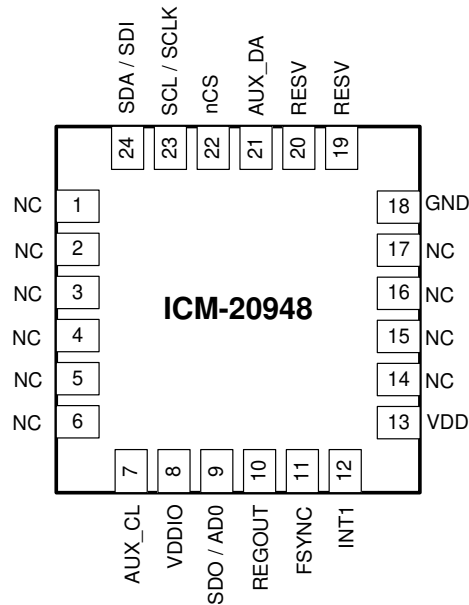

Figure 3. Pin out Diagram for ICM-20948 3 mm x 3 mm x 1 mm QFN

4.2 TYPICAL OPERATING CIRCUIT

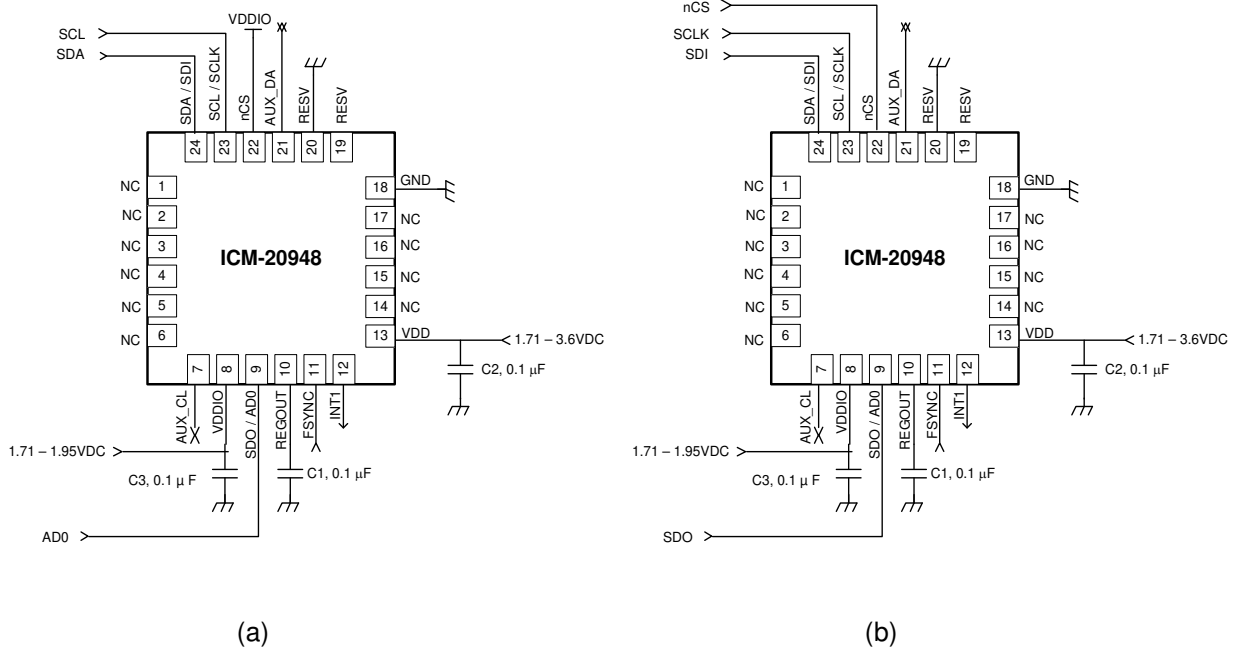

Figure 4. ICM-20948 Application Schematic (a) I²C operation (b) SPI operation

Note that the INT pin should be connected to a GPIO pin on the system processor that is capable of waking the system processor from suspend mode.

I²C lines are open drain and pullup resistors (e.g. 10 kΩ) are required.

4.3 BILL OF MATERIALS FOR EXTERNAL COMPONENTS

COMPONENT	LABEL	SPECIFICATION	QUANTITY
Regulator Filter Capacitor	C1	Ceramic, X7R, 0.1 μF ±10%, 2V	1
VDD Bypass Capacitor	C2	Ceramic, X7R, 0.1 μF ±10%, 4V	1
VDDIO Bypass Capacitor	C3	Ceramic, X7R, 0.1 μF ±10%, 4V	1

Table 11. Bill of Materials

4.4 EXPOSED DIE PAD PRECAUTIONS

InvenSense products have very low active and standby current consumption. The exposed die pad is not required for heat sinking, and should not be soldered to the PCB. Failure to adhere to this rule can induce performance changes due to package thermo-mechanical stress. There is no electrical connection between the pad and the CMOS.

4.5 BLOCK DIAGRAM

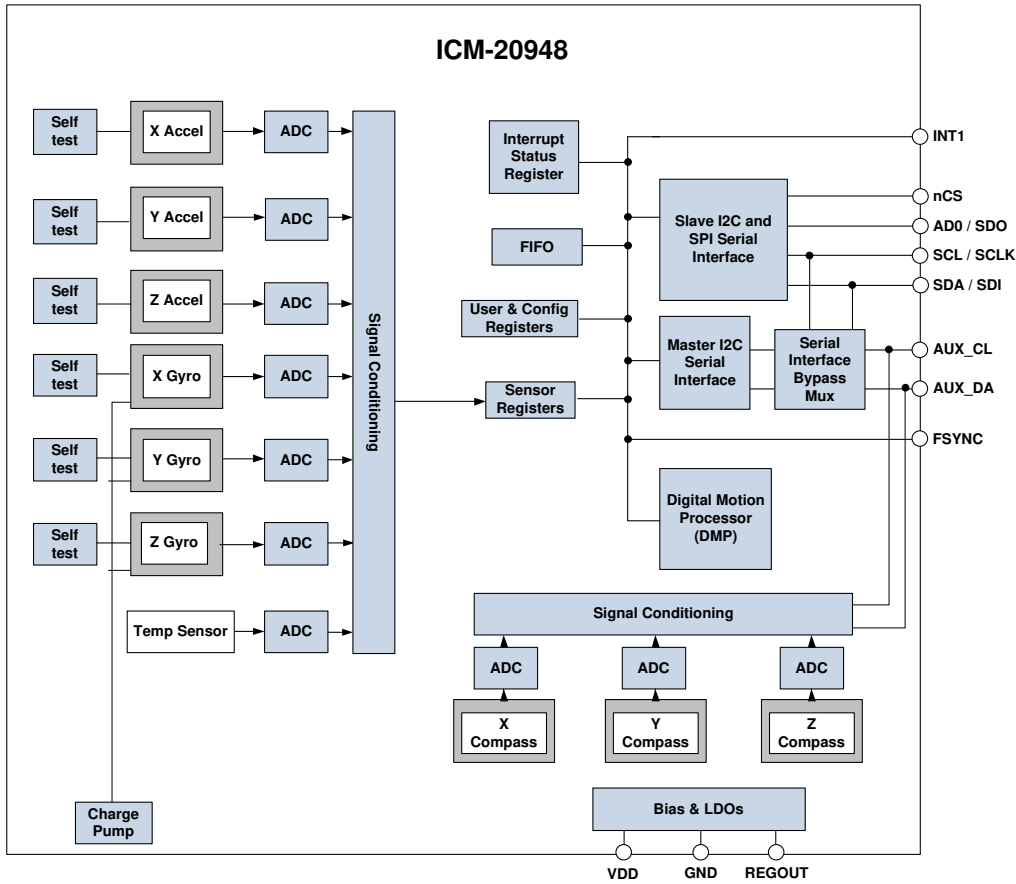

Figure 5. ICM-20948 Block Diagram

4.6 OVERVIEW

The ICM-20948 is comprised of the following key blocks and functions:

- Three-axis MEMS rate gyroscope sensor with 16-bit ADCs and signal conditioning
- Three-axis MEMS accelerometer sensor with 16-bit ADCs and signal conditioning
- Three-axis MEMS magnetometer sensor with 16-bit ADCs and signal conditioning
- Digital Motion Processor (DMP) engine
- Primary I²C and SPI serial communications interfaces
- Auxiliary I²C serial interface
- Gyroscope, Accelerometer, and Magnetometer Self-Test
- Clocking
- Sensor Data Registers
- FIFO
- FSYNC
- Interrupts
- Digital-Output Temperature Sensor
- Bias and LDOs
- Charge Pump
- Power Modes

4.7 THREE-AXIS MEMS GYROSCOPE WITH 16-BIT ADCS AND SIGNAL CONDITIONING

The ICM-20948 consists of three independent vibratory MEMS rate gyroscopes, which detect rotation about the X-, Y-, and Z-Axes. When the gyros are rotated about any of the sense axes, the Coriolis Effect causes a vibration that is detected by a capacitive pickoff. The resulting signal is amplified, demodulated, and filtered to produce a voltage that is proportional to the angular rate. This voltage is digitized using individual on-chip 16-bit Analog-to-Digital Converters (ADCs) to sample each axis. The full-scale range of the gyro sensors may be digitally programmed to ± 250 , ± 500 , ± 1000 , or ± 2000 degrees per second (dps).

4.8 THREE-AXIS MEMS ACCELEROMETER WITH 16-BIT ADCS AND SIGNAL CONDITIONING

The ICM-20948's 3-Axis accelerometer uses separate proof masses for each axis. Acceleration along a particular axis induces displacement on the corresponding proof mass, and capacitive sensors detect the displacement differentially. The ICM-20948's architecture reduces the accelerometers' susceptibility to fabrication variations as well as to thermal drift. When the device is placed on a flat surface, it will measure $0g$ on the X- and Y-axes and $+1g$ on the Z-axis. The accelerometers' scale factor is calibrated at the factory and is nominally independent of supply voltage. Each sensor has a dedicated sigma-delta ADC for providing digital outputs. The full scale range of the digital output can be adjusted to $\pm 2g$, $\pm 4g$, $\pm 8g$, or $\pm 16g$.

4.9 THREE-AXIS MEMS MAGNETOMETER WITH 16-BIT ADCS AND SIGNAL CONDITIONING

The 3-axis magnetometer uses highly sensitive Hall sensor technology. The magnetometer portion of the IC incorporates magnetic sensors for detecting terrestrial magnetism in the X-, Y-, and Z-Axes, a sensor driving circuit, a signal amplifier chain, and an arithmetic circuit for processing the signal from each sensor. Each ADC has a 16-bit resolution and a full scale range of $\pm 4900 \mu T$.

4.10 DIGITAL MOTION PROCESSOR

The embedded Digital Motion Processor (DMP) within the ICM-20948 offloads computation of motion processing algorithms from the host processor. The DMP acquires data from accelerometers, gyroscopes, and additional third party sensors such as magnetometers, and processes the data. The resulting data can be read from the FIFO. The DMP has access to the external pins, which can be used for generating interrupts.

The purpose of the DMP is to offload both timing requirements and processing power from the host processor. Typically, motion processing algorithms should be run at a high rate, often around 200 Hz, in order to provide accurate results with low latency. This is required even if the application updates at a much lower rate; for example, a low power user interface may update as slowly as 5 Hz, but the motion processing should still run at 200 Hz. The DMP can be used to minimize power, simplify timing, simplify the software architecture, and save valuable MIPS on the host processor for use in applications.

4.11 PRIMARY I²C AND SPI SERIAL COMMUNICATIONS INTERFACES

The ICM-20948 communicates to a system processor using either a SPI or an I²C serial interface. The ICM-20948 always acts as a slave when communicating to the system processor. The LSB of the of the I²C slave address is set by pin 1 (AD0).

ICM-20948 Solution Using I²C Interface

In Figure 6, the system processor is an I²C master to the ICM-20948. In addition, the ICM-20948 is an I²C master to the optional external sensor. The ICM-20948 has limited capabilities as an I²C Master, and depends on the system processor to manage the initial configuration of any auxiliary sensors. The ICM-20948 has an interface bypass multiplexer, which connects the system processor I²C bus pins 23 and 24 (SCL and SDA) directly to the auxiliary sensor I²C bus pins 7 and 21 (AUX_CL and AUX_DA).

Once the auxiliary sensors have been configured by the system processor, the interface bypass multiplexer should be disabled so that the ICM-20948 auxiliary I²C master can take control of the sensor I²C bus and gather data from the auxiliary sensors.

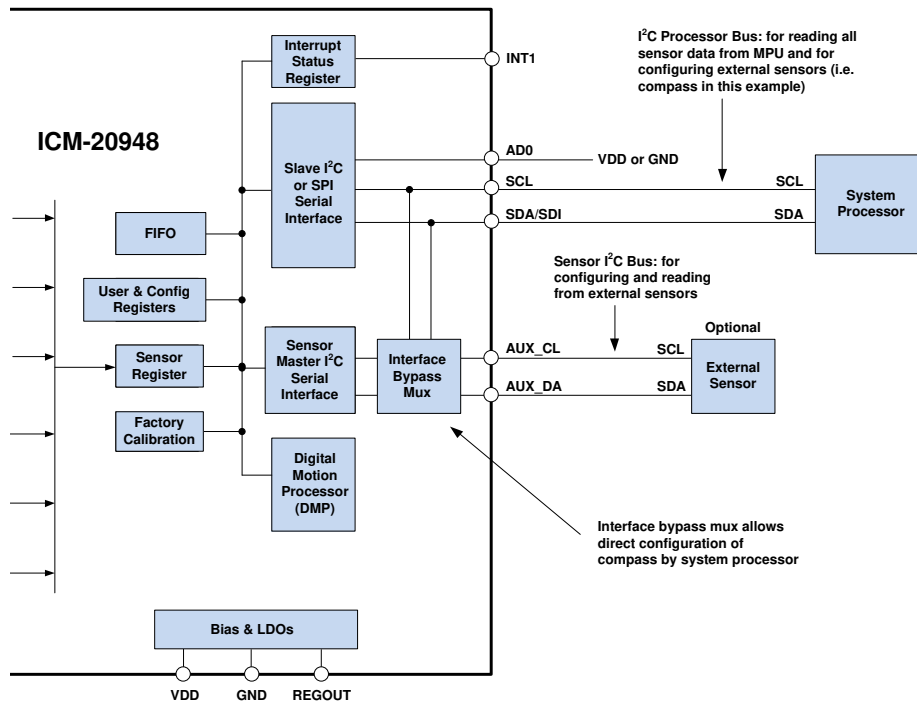

Figure 6. ICM-20948 Solution Using I²C Interface

ICM-20948 Solution Using SPI Interface

In Figure 7, the system processor is an SPI master to the ICM-20948. Pins 9, 22, 23, and 24 are used to support the SDO, nCS, SCLK, and SDI signals for SPI communications. Because these SPI pins are shared with the I²C slave pins (9, 23 and 24), the system processor cannot access the auxiliary I²C bus through the interface bypass multiplexer, which connects the processor I²C interface pins to the sensor I²C interface pins. Since the ICM-20948 has limited capabilities as an I²C Master, and depends on the system processor to manage the initial configuration of any auxiliary sensors, another method must be used for programming the sensors on the auxiliary sensor I²C bus pins 7 and 21 (AUX_CL and AUX_DA).

When using SPI communications between the ICM-20948 and the system processor, configuration of devices on the auxiliary I²C sensor bus can be achieved by using I²C Slaves 0-4 to perform read and write transactions on any device and register on the auxiliary I²C bus. The I²C Slave 4 interface can be used to perform only single byte read and write transactions. Once the external sensors have been configured, the ICM-20948 can perform single or multi-byte reads using the sensor I²C bus. The read results from the Slave 0-3 controllers can be written to the FIFO buffer as well as to the external sensor registers.

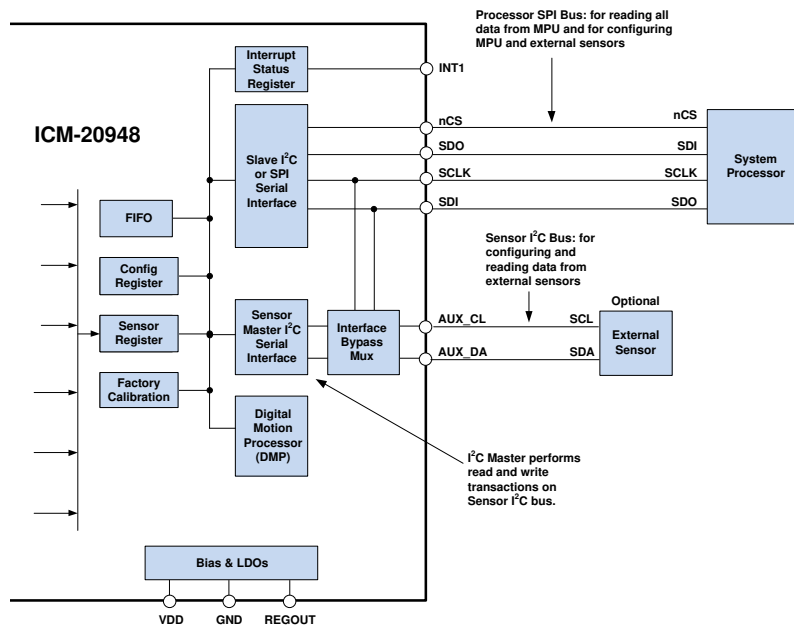

Figure 7. ICM-20948 Solution Using SPI Interface

4.12 AUXILIARY I²C SERIAL INTERFACE

The ICM-20948 has an auxiliary I²C bus for communicating to external sensors. This bus has two operating modes:

- **I²C Master Mode:** The ICM-20948 acts as a master to any external sensors connected to the auxiliary I²C bus
- **Pass-Through Mode:** The ICM-20948 directly connects the primary and auxiliary I²C buses together, allowing the system processor to directly communicate with any external sensors.

Auxiliary I²C Bus Modes of Operation:

- **I²C Master Mode:** Allows the ICM-20948 to directly access the data registers of external sensors. In this mode, the ICM-20948 directly obtains data from auxiliary sensors without intervention from the system applications processor. The I²C Master can be configured to read up to 24 bytes from up to 4 auxiliary sensors. A fifth sensor can be configured to work single byte read/write mode.
- **Pass-Through Mode:** Allows an external system processor to act as master and directly communicate to the external sensors connected to the auxiliary I²C bus pins (AUX_DA and AUX_CL). In this mode, the auxiliary I²C bus control logic of the ICM-20948 is disabled, and the auxiliary I²C pins AUX_CL and AUX_DA (pins 7 and 21) are connected to the main I²C bus (Pins 23 and 24) through analog switches internally. Pass-Through mode is useful for configuring the external sensors.

4.13 SELF-TEST

Self-test allows for the testing of the mechanical and electrical portions of the sensors. The self-test for each measurement axis can be activated by means of the gyroscope and accelerometer self-test registers.

When the self-test is activated, the electronics cause the sensors to be actuated and produce an output signal. The output signal is used to observe the self-test response.

The self-test response is defined as follows:

$$\text{SELF-TEST RESPONSE} = \text{SENSOR OUTPUT WITH SELF-TEST ENABLED} - \text{SENSOR OUTPUT WITHOUT SELF-TEST ENABLED}$$

The self-test response for each gyroscope axis is defined in the gyroscope specification table, while that for each accelerometer axis is defined in the accelerometer specification table.

When the value of the self-test response is within the specified min/max limits, the part has passed self-test. When the self-test response exceeds the min/max values, the part is deemed to have failed self-test. It is recommended to use InvenSense MotionApps software for executing self-test.

4.14 CLOCKING

The internal system clock sources include: (1) an internal relaxation oscillator, and (2) a PLL with MEMS gyroscope oscillator as the reference clock. With the recommended clock selection setting (CLKSEL = 1), the best clock source for optimum sensor performance and power consumption will be automatically selected based on the power mode. Specifically, the internal relaxation oscillator will be selected when operating in accelerometer only mode, while the PLL will be selected whenever gyroscope is on, which includes gyroscope and 6-axis modes.

As clock accuracy is critical to the preciseness of distance and angle calculations performed by DMP, it should be noted that the internal relaxation oscillator and PLL show different performances in some aspects. The internal relaxation oscillator is trimmed to have a consistent operating frequency at room temperature, while the PLL clock frequency varies from part to part. The PLL frequency deviation from the nominal value in percentage is captured in register TIMEBASE_CORRECTION_PLL (detailed in section 12.5), and users can factor it in during distance and angle calculations to not sacrifice accuracy. Other than that, PLL has better frequency stability and lower frequency variation over temperature than the internal relaxation oscillator.

4.15 SENSOR DATA REGISTERS

The sensor data registers contain the latest gyro, accelerometer, auxiliary sensor, and temperature measurement data. They are read-only registers, and are accessed via the serial interface. Data from these registers may be read anytime.

4.16 FIFO

The ICM-20948 contains a FIFO of size 512 bytes (FIFO size will vary depending on DMP feature-set) that is accessible via the Serial Interface. The FIFO configuration register determines which data is written into the FIFO. Possible choices include gyro data, accelerometer data, temperature readings, auxiliary sensor readings, and FSYNC input.

A FIFO counter keeps track of how many bytes of valid data are contained in the FIFO. The FIFO register supports burst reads. The interrupt function may be used to determine when new data is available.

For further information regarding the FIFO, please refer to the Section 7.

4.17 FSYNC

The FSYNC pin can be used from an external interrupt source to wake up the device from sleep. It is particularly useful in EIS applications to synchronize the gyroscope ODR with external inputs from an imaging sensor. Connecting the VSYNC or HSYNC pin of the image sensor subsystem to FSYNC on ICM-20948 allows timing synchronization between the two otherwise unconnected subsystems.

An FSYNC_ODR delay time register is used to capture the delay between an FSYNC pulse and the very next gyroscope data ready pulse.

4.18 INTERRUPTS

Interrupt functionality is configured via the Interrupt Configuration register. Items that are configurable include the INT pin configuration, the interrupt latching and clearing method, and triggers for the interrupt. Section 5 provides a summary of interrupt sources. The interrupt status can be read from the Interrupt Status register.

For further information regarding interrupts, please refer to Section 7.