



Chipsmall Limited consists of a professional team with an average of over 10 year of expertise in the distribution of electronic components. Based in Hongkong, we have already established firm and mutual-benefit business relationships with customers from,Europe,America and south Asia,supplying obsolete and hard-to-find components to meet their specific needs.

With the principle of "Quality Parts,Customers Priority,Honest Operation,and Considerate Service",our business mainly focus on the distribution of electronic components. Line cards we deal with include Microchip,ALPS,ROHM,Xilinx,Pulse,ON,Everlight and Freescale. Main products comprise IC,Modules,Potentiometer,IC Socket,Relay,Connector.Our parts cover such applications as commercial,industrial, and automotives areas.

We are looking forward to setting up business relationship with you and hope to provide you with the best service and solution. Let us make a better world for our industry!



## Contact us

Tel: +86-755-8981 8866 Fax: +86-755-8427 6832

Email & Skype: info@chipsmall.com Web: www.chipsmall.com

Address: A1208, Overseas Decoration Building, #122 Zhenhua RD., Futian, Shenzhen, China



## MODEL ICM8 – ETHERNET GATEWAY FOR RED LION PANEL METERS WITH RLC SERIAL PROTOCOL



- ETHERNET GATEWAY FOR RED LION PANEL METERS WITH RLC SERIAL PROTOCOL
- PROGRAMMABLE VIA CRIMSON® SOFTWARE
- USB PROGRAMMING PORT
- EXTENSIVE ETHERNET DRIVER LIST ALLOWS EASY DATA MAPPING TO PLCs, PCS, AND SCADA SYSTEMS
- 10 BASE-T/100 BASE-TX ETHERNET



### GENERAL DESCRIPTION

The ICM8 is designed to act as an ethernet gateway offering multiple protocol conversion for Red Lion panel meters. With two serial ports (one RS232 and one RS485) and a 10 Base-T/100 Ethernet Port, the unit performs protocol conversion, allowing Red Lion panel meters to communicate seamlessly to the ethernet network. Programming the unit can be accomplished via the RS232 or the USB Port using Crimson® Software. It is important to note that this device is designed to function with Red Lion panel meters and will not offer protocol conversion if a Red Lion Product is not connected to at least one of the serial ports.

The ICM8'S DIN rail mounting saves time and panel space and snaps easily onto standard top hat (T) profile DIN rail.

### SOFTWARE

The ICM8 is programmed with Windows® compatible Crimson software. The software is an easy to use graphical interface that can be downloaded free of charge from www.redlion.net.

### SAFETY SUMMARY

All safety related regulations, local codes and instructions that appear in the manual or on equipment must be observed to ensure personal safety and to prevent damage to either the instrument or equipment connected to it. If equipment is used in a manner not specified by the manufacturer, the protection provided by the equipment may be impaired.



**CAUTION: Risk of Danger.**  
 Read complete instructions prior to installation and operation of the unit.

### ORDERING INFORMATION

MODEL NO.	DESCRIPTION	PART NUMBER
ICM8	Communication Gateway	ICM80000
PSDR	DIN Rail Power Supply	PSDRxxxx
SFCRD2	Crimson 2.0 Programming Software <sup>2</sup>	SFCRD2xx
CBL	RS-232 Programming Cable	CBLPROG0
	USB Cable	CBLUSB00
	Communications Cables <sup>1</sup>	CBLxxxxx
DR	DIN Rail Mountable Adapter Products <sup>3</sup>	DRxxxxxx

<sup>1</sup> Contact your Red Lion distributor or visit our website for complete selection.

<sup>2</sup> Free at www.redlion.net

<sup>3</sup> Red Lion offers RJ modular jack adapters. Refer to the DR literature for complete details.

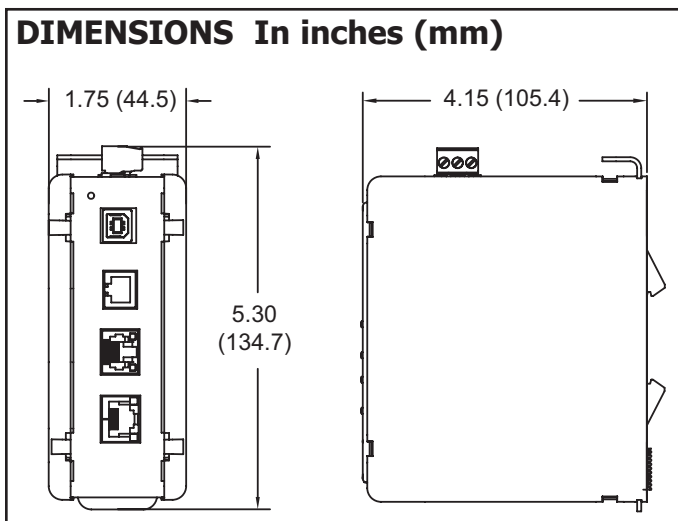

## SPECIFICATIONS

- POWER:** 24 VDC  $\pm$  10% 200 mA max.  
Must use a Class 2 circuit according to National Electrical Code (NEC), NFPA-70 or Canadian Electrical Code (CEC), Part I, C22.1 or a Limited Power Supply (LPS) according to IEC 60950-1 or Limited-energy circuit according to IEC 61010-1.
- COMMUNICATIONS:**  
**USB/PG Port:** Adheres to USB specification 1.1. Device only using Type B connection.  
**Serial Ports:** Format and Baud Rates for each port are individually software programmable up to 115,200 baud.  
**RS232/PG Port:** RS232 port via RJ12  
**COMMS Ports:** RS485 port via RJ11  
**Ethernet Port:** 10 BASE-T / 100 BASE-TX
- LEDs:**  
STS – Status LED indicates condition of ICM8.  
TX/RX – Transmit/Receive LEDs show serial activity.  
Ethernet – Link and activity LEDs.
- MEMORY:**  
On-board User Memory: 4 Mbytes of non-volatile Flash memory.  
On-board SDRAM: 2 Mbytes

## 5. CERTIFICATIONS AND COMPLIANCES:

### CE Approved

EN 61326-1 Immunity to Industrial Locations

Emission CISPR 11 Class A

Safety requirements for electrical equipment for measurement, control, and laboratory use:

EN 61010-1: General Requirements

IP20 Enclosure rating

## 6. ENVIRONMENTAL CONDITIONS:

Operating Temperature Range: 0 to 50°C

Storage Temperature Range: -30 to +70°C

Operating and Storage Humidity: 80% max relative humidity, non-condensing, from 0 to 50°C

Vibration to IEC 68-2-6: Operational 5 to 150 Hz, 2 g.

Shock to IEC 68-2-27: Operational 25 g.

Altitude: Up to 2000 meters

## 7. CONSTRUCTION:

Case body is black high impact plastic and stainless steel. Installation Category I, Pollution Degree 2.

## 8. POWER CONNECTION:

Removable wire clamp screw terminal block.

Wire Gage Capacity: 24 AWG to 12 AWG

Torque: 4.45 to 5.34 in/lb (0.5 to 0.6 N-m)

## 9. MOUNTING:

Snaps onto standard DIN style top hat (T) profile mounting rails according to EN50022 -35 x 7.5 and -35 x 15.

## 10. WEIGHT:

12.3 oz (348g)

## HARDWARE INSTALLATION

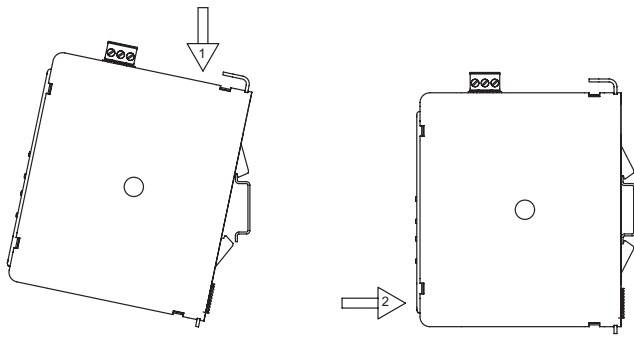

Figure 1 - Attach ICM8 To DIN Rail

## POWER SUPPLY REQUIREMENTS

It is very important that the power supply is mounted correctly if the unit is to operate reliably. Please take care to observe the following points:

- The power supply must be mounted close to the unit, with usually not more than 6 feet (1.8 m) of cable between the supply and the ICM8. Ideally, the shortest length possible should be used.
- The wire used to connect the ICM8's power supply should be at least 22-gauge wire. If a longer cable run is used, a heavier gage wire should be used. The routing of the cable should be kept away from large contactors, inverters, and other devices which may generate significant electrical noise.
- A power supply with a Class 2 or SELV rating is to be used. A Class 2 or SELV power supply provides isolation to accessible circuits from hazardous voltage levels generated by a mains power supply due to single faults. SELV is an acronym for "safety extra-low voltage." Safety extra-low voltage circuits shall exhibit voltages safe to touch both under normal operating conditions and after a single fault, such as a breakdown of a layer of basic insulation or after the failure of a single component has occurred.

## ICM8 PORT PIN OUTS

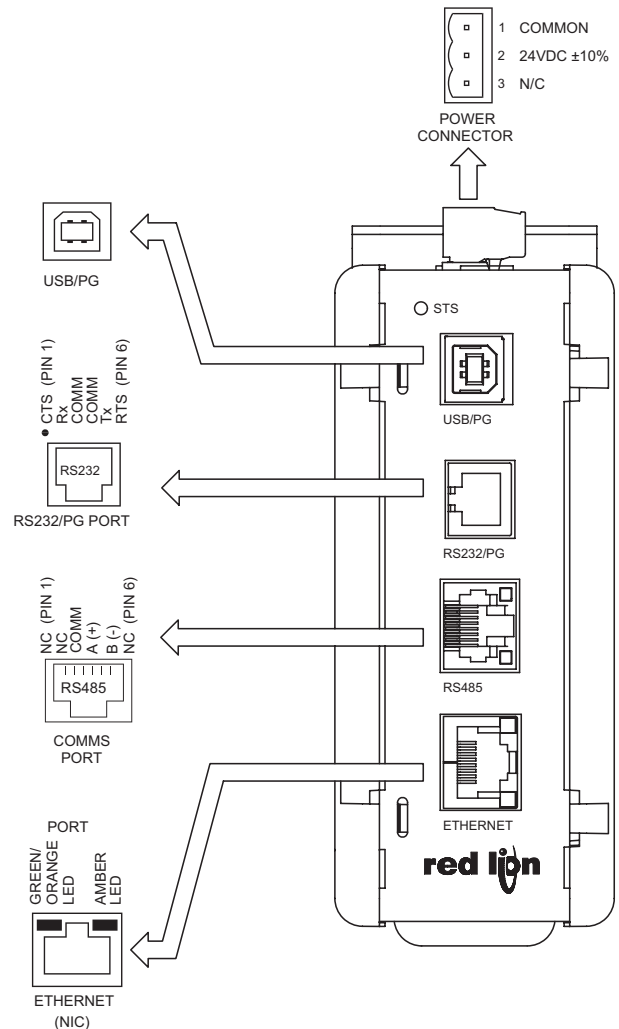

## EMC INSTALLATION GUIDELINES

Although Red Lion Controls Products are designed with a high degree of immunity to Electromagnetic Interference (EMI), proper installation and wiring methods must be followed to ensure compatibility in each application. The type of the electrical noise, source or coupling method into a unit may be different for various installations. Cable length, routing, and shield termination are very important and can mean the difference between a successful or troublesome installation. Listed are some EMI guidelines for a successful installation in an industrial environment.

1. A unit should be mounted in a metal enclosure, which is properly connected to protective earth.
2. Use shielded cables for all Signal and Control inputs. The shield connection should be made as short as possible. The connection point for the shield depends somewhat upon the application. Listed below are the recommended methods of connecting the shield, in order of their effectiveness.
  - a. Connect the shield to earth ground (protective earth) at one end where the unit is mounted.
  - b. Connect the shield to earth ground at both ends of the cable, usually when the noise source frequency is over 1 MHz.
3. Never run Signal or Control cables in the same conduit or raceway with AC power lines, conductors, feeding motors, solenoids, SCR controls, and heaters, etc. The cables should be run through metal conduit that is properly grounded. This is especially useful in applications where cable runs are long and portable two-way radios are used in close proximity or if the installation is near a commercial radio transmitter. Also, Signal or Control cables within an enclosure should be routed as far away as possible from contactors, control relays, transformers, and other noisy components.
4. Long cable runs are more susceptible to EMI pickup than short cable runs.
5. In extremely high EMI environments, the use of external EMI suppression devices

such as Ferrite Suppression Cores for signal and control cables is effective. The following EMI suppression devices (or equivalent) are recommended:

Fair-Rite part number 0443167251 (RLC part number FCOR0000)

Line Filters for input power cables:

Schaffner # FN2010-1/07 (Red Lion Controls # LFIL0000)

6. To protect relay contacts that control inductive loads and to minimize radiated and conducted noise (EMI), some type of contact protection network is normally installed across the load, the contacts or both. The most effective location is across the load.
  - a. Using a snubber, which is a resistor-capacitor (RC) network or metal oxide varistor (MOV) across an AC inductive load is very effective at reducing EMI and increasing relay contact life.
  - b. If a DC inductive load (such as a DC relay coil) is controlled by a transistor switch, care must be taken not to exceed the breakdown voltage of the transistor when the load is switched. One of the most effective ways is to place a diode across the inductive load. Most RLC products with solid state outputs have internal zener diode protection. However external diode protection at the load is always a good design practice to limit EMI. Although the use of a snubber or varistor could be used.  
RLC part numbers: Snubber: SNUB0000  
Varistor: ILS11500 or ILS23000
7. Care should be taken when connecting input and output devices to the instrument. When a separate input and output common is provided, they should not be mixed. Therefore a sensor common should NOT be connected to an output common. This would cause EMI on the sensitive input common, which could affect the instrument's operation.  
Visit RLC's web site at <http://www.redlion.net/Support/InstallationConsiderations.html> for more information on EMI guidelines, Safety and CE issues as they relate to Red Lion Controls products.

## WIRING

### POWER CONNECTION

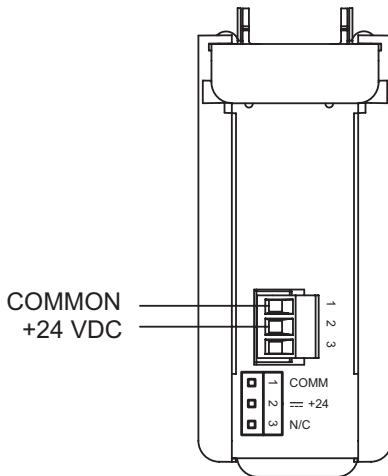

### TROUBLESHOOTING

1. This module is designed to operate with Red Lion panel meters only. Please make sure a Red Lion product is connected to either one of the two serial ports for the gateway to be active.
2. The Ethernet port is equipped with data LEDs. If they are blinking, the converter is active and the data is available at the port. Please verify the receiving equipment is properly programmed.
3. If for any reason you have trouble operating, connecting, or simply have questions concerning your new ICM8, contact Red Lion's technical support. For contact information, refer to the back page of this bulletin for phone and fax numbers.

EMAIL: [techsupport@redlion.net](mailto:techsupport@redlion.net)  
Web Site: <http://www.redlion.net>

### PROGRAMMING PORTS

#### USB/PG

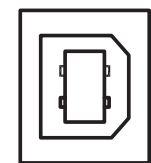

#### RS232/PG

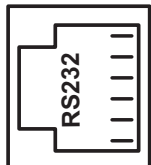

CTS  
Rx  
COMM  
COMM  
Tx  
RTS

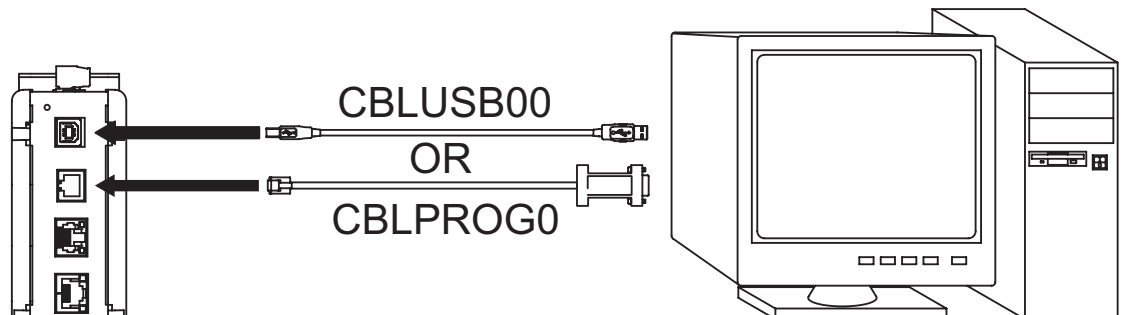

# COMMUNICATION PORTS

## RS232/PG

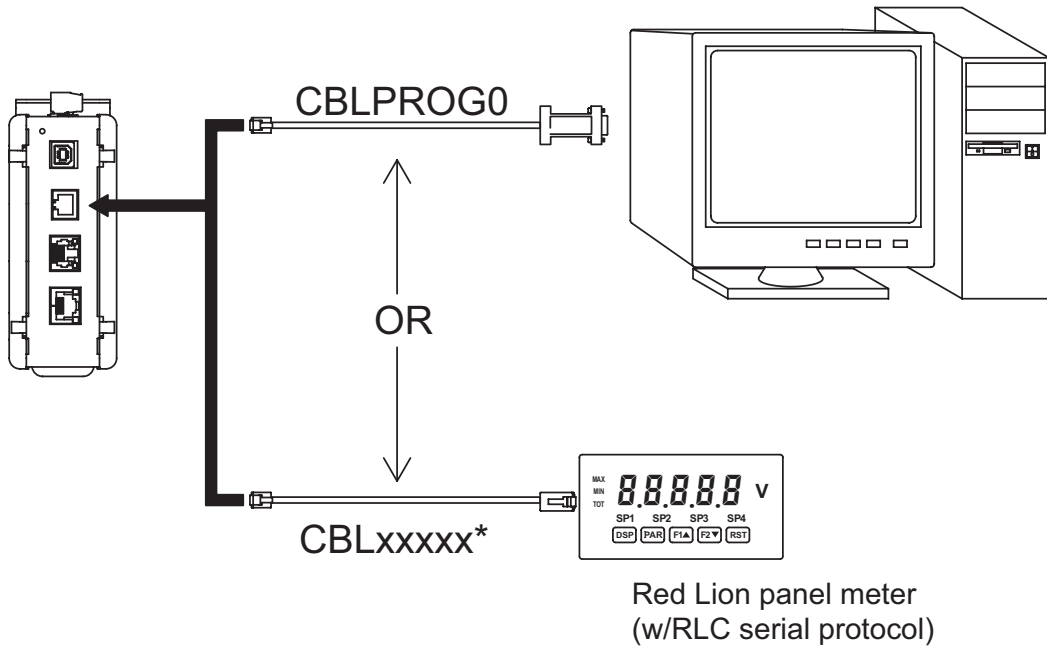
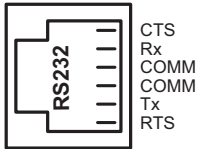

\* Use appropriate communications cable.  
See Ordering Information for descriptions of the available cables.

## RS485

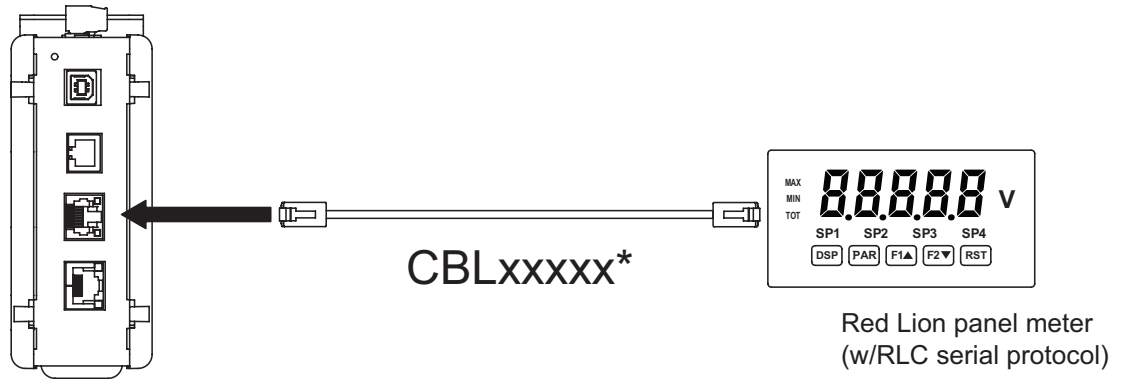
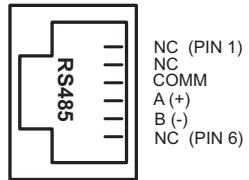

---

## PORT 3 - ETHERNET CONNECTION

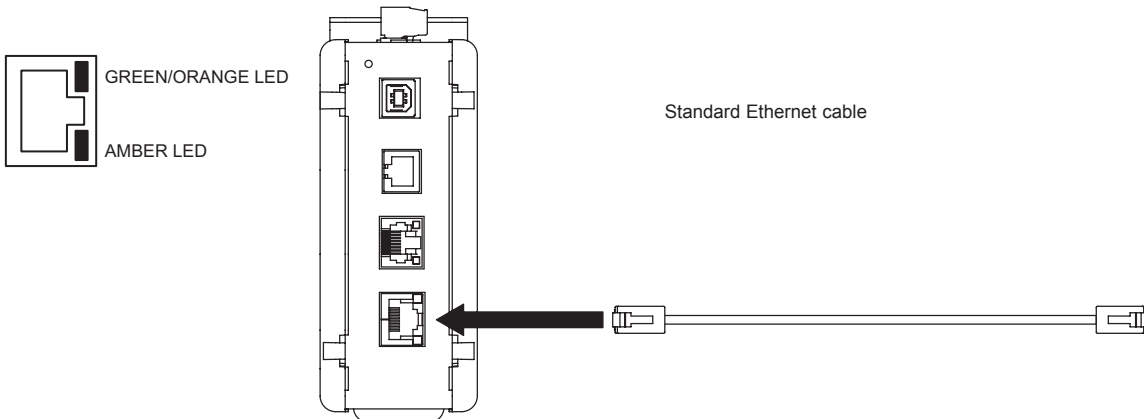

# COMMUNICATING WITH THE ICM8

## CONFIGURING THE ICM8

The ICM8 is configured using Crimson software. Crimson is available as a free download from Red Lion's website, or it can be ordered on CD. Updates to Crimson for new features and drivers are posted on the website as they become available. Crimson software can configure the ICM8 through the RS232/PG port or USB/PG port. The USB/PG port is connected using a standard USB cable with a Type B connector.

The driver needed to use the USB port will be installed with Crimson. The RS232/PG port uses a programming cable made by Red Lion to connect to the DB9 COM port of your computer. If making your own cable, refer to the "ICM8 Port Pin Outs" for wiring information.

## ETHERNET COMMUNICATIONS

Ethernet communications can be established at either 10 BASE-T or 100 BASE-TX. The Crimson manual contains additional information on Ethernet communications.

## RS232 PORTS

The ICM8 has one RS232 port. The port can be used for programming or communications.

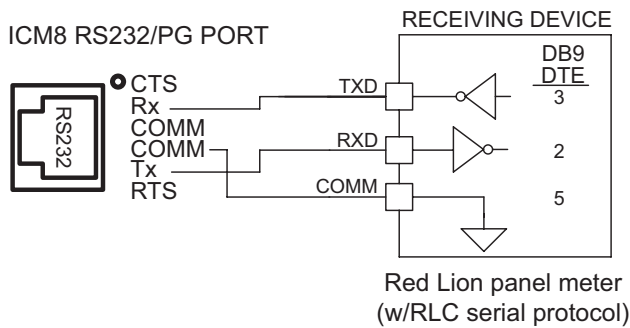

## RS485 PORT

The ICM8 has one RS485 port.

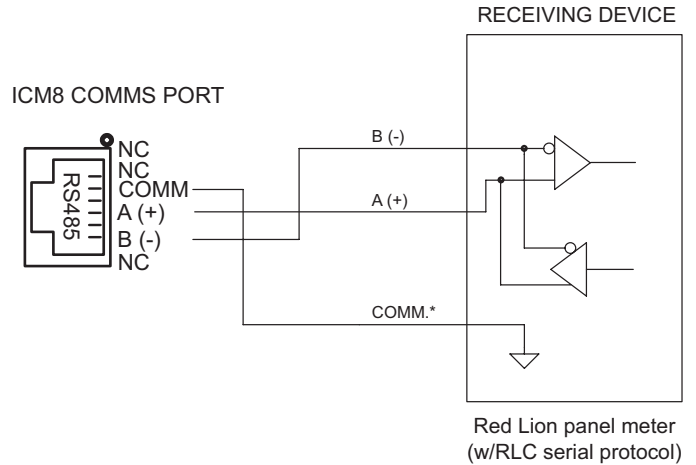

Note: All Red Lion devices connect A to A and B to B.

\*RS485 common connection is optional.

## LEDS

### STS – STATUS LED

The green Status LED provides information regarding the state of the ICM8. This includes indication of the various stages of the start-up routine (power-up), and any errors that may occur.

### Startup Routing

	INDICATION
Rapidly Flashing	ICM8 is currently running the boot loader and/or being flash upgraded by Crimson
Steady	ICM8 is operating properly

## ETHERNET LEDES

LED	INDICATION
YELLOW (Solid)	Link Established
YELLOW (Flashing)	Network Activity
GREEN	10 BASE-T Communications
AMBER	100 BASE-T Communications

## USER COMMUNICATION PORTS - TX/RX LEDES

LED	INDICATION
GREEN	Transmitting
RED	Receiving

This page intentionally left blank

This page intentionally left blank



### **LIMITED WARRANTY**

The Company warrants the products it manufactures against defects in materials and workmanship for a period limited to two years from the date of shipment, provided the products have been stored, handled, installed, and used under proper conditions. The Company's liability under this limited warranty shall extend only to the repair or replacement of a defective product, at The Company's option. The Company disclaims all liability for any affirmation, promise or representation with respect to the products.

The customer agrees to hold Red Lion Controls harmless from, defend, and indemnify RLC against damages, claims, and expenses arising out of subsequent sales of RLC products or products containing components manufactured by RLC and based upon personal injuries, deaths, property damage, lost profits, and other matters which Buyer, its employees, or sub-contractors are or may be to any extent liable, including without limitation penalties imposed by the Consumer Product Safety Act (P.L. 92-573) and liability imposed upon any person pursuant to the Magnuson-Moss Warranty Act (P.L. 93-637), as now in effect or as amended hereafter.

No warranties expressed or implied are created with respect to The Company's products except those expressly contained herein. The Customer acknowledges the disclaimers and limitations contained herein and relies on no other warranties or affirmations.

Red Lion Controls  
Headquarters  
20 Willow Springs Circle  
York PA 17406  
Tel +1 (717) 767-6511  
Fax +1 (717) 764-0839

Red Lion Controls  
Europe  
Softwareweg 9  
NL - 3821 BN Amersfoort  
Tel +31 (0) 334 723 225  
Fax +31 (0) 334 893 793

Red Lion Controls  
India  
201-B, 2nd Floor, Park Centra  
Opp 32 Mile Stone, Sector-30  
Gurgaon-122002 Haryana, India  
Tel +91 984 487 0503

Red Lion Controls  
China  
Unit 302, XinAn Plaza  
Building 13, No.99 Tianzhou Road  
ShangHai, P.R. China 200223  
Tel +86 21 6113 3688  
Fax +86 21 6113 3683