



Chipsmall Limited consists of a professional team with an average of over 10 year of expertise in the distribution of electronic components. Based in Hongkong, we have already established firm and mutual-benefit business relationships with customers from,Europe,America and south Asia,supplying obsolete and hard-to-find components to meet their specific needs.

With the principle of “Quality Parts,Customers Priority,Honest Operation,and Considerate Service”,our business mainly focus on the distribution of electronic components. Line cards we deal with include Microchip,ALPS,ROHM,Xilinx,Pulse,ON,Everlight and Freescale. Main products comprise IC,Modules,Potentiometer,IC Socket,Relay,Connector.Our parts cover such applications as commercial,industrial, and automotives areas.

We are looking forward to setting up business relationship with you and hope to provide you with the best service and solution. Let us make a better world for our industry!



Contact us

Tel: +86-755-8981 8866 Fax: +86-755-8427 6832

Email & Skype: info@chipsmall.com Web: www.chipsmall.com

Address: A1208, Overseas Decoration Building, #122 Zhenhua RD., Futian, Shenzhen, China



LOW EMI CLOCK GENERATOR

ICS180-52

Description

The ICS180-52 generates a low EMI output clock from a clock or crystal input. The device uses IDT's proprietary mix of analog and digital Phase-Locked Loop (PLL) technology to spread the frequency spectrum of the output, thereby reducing the frequency amplitude peaks by several dB.

The ICS180-52 offers center spread selection of +/-0.625% and +/-1.875%. Refer to the MK1714-01/02 for the widest selection of input frequencies and multipliers.

IDT offers a complete line of EMI reducing clock generators. Consult us when you need to remove crystals and oscillators from your board.

Features

- Pin and function compatible to Cypress W180-52
- Packaged in 8-pin SOIC
- Provides a spread spectrum output clock
- Accepts a clock input and provides same frequency dithered output
- Input frequency of 8 to 15 MHz
- Peak reduction by 7dB - 14dB typical on 3rd - 19th odd harmonics
- Spread percentage selection for +/-0.625% and +/-1.875%
- Operating voltage of 3.3 V and 5 V
- Advanced, low-power CMOS process

NOTE: EOL for non-green parts to occur on 5/13/10 per PDN U-09-01

Block Diagram

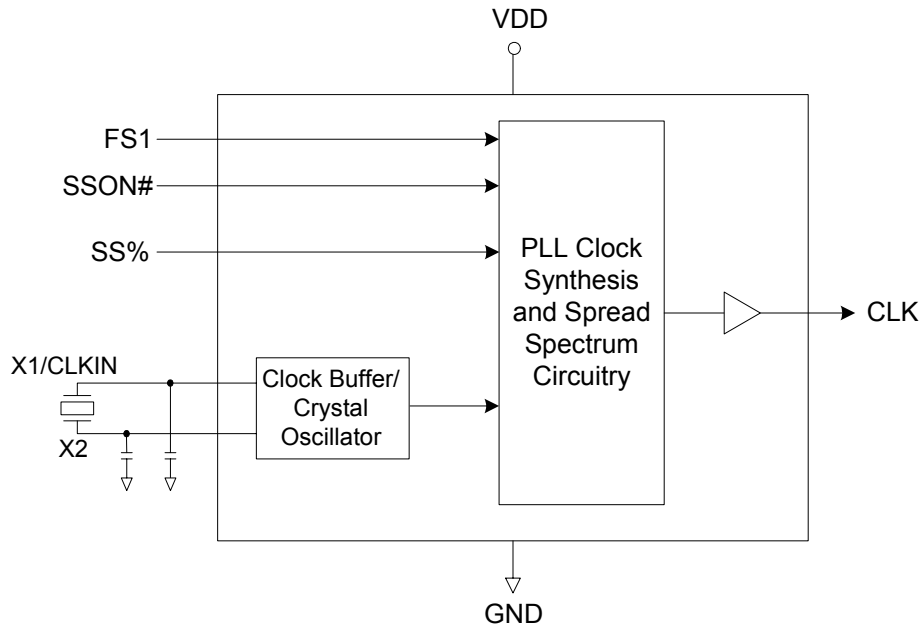

Pin Assignment

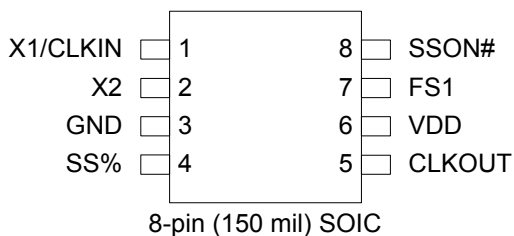

Spread Spectrum Select Table

| SS% (Pin 4) | Spread Direction | Spread Percentage (%) |
|-------------|------------------|-----------------------|
| 0 | Center | +/-0.625% |
| 1 | Center | +/-1.875% |

0 = connect to GND

1 = connect directly to VDD

Note: SS% pin has an internal pull-up resistor

Frequency Range Selection Table

| FS1 (Pin 7) | Frequency Range Selection (MHz) |
|-------------|---------------------------------|
| 0 | 8-10 |
| 1 | 10-15 |

Pin Descriptions

| Pin Number | Pin Name | Pin Type | Pin Description |
|------------|----------|----------|--|
| 1 | X1/CLKIN | Input | Crystal or Clock Input. |
| 2 | X2 | Output | Crystal output. Float for a clock input. |
| 3 | GND | Power | Connect to ground. |
| 4 | SS% | Input | Select pin for spread amount. See table above. Internal pull-up resistor. |
| 5 | CLKOUT | Output | Spread spectrum clock output per table above. |
| 6 | VDD | Power | Connect to 3.3 V or 5 V. |
| 7 | FS1 | Input | Select pin for input frequency. See table above. Internal pull-up resistor. |
| 8 | SSON# | Input | Spread Spectrum Control. This pin enables spread spectrum when low. Internal pull-down resistor. |

External Components

The ICS180-52 requires a minimum number of external components for proper operation.

Decoupling Capacitor

A decoupling capacitor of 0.01 μ F must be connected between VDD and GND on pins 6 and 3, as close to these pins as possible. For optimum device performance, the decoupling capacitor should be mounted on the component side of the PCB. Avoid the use of vias in the decoupling circuit.

Series Termination Resistor

When the PCB trace between the clock output and the load is over 1 inch, series termination should be used. To series terminate a 50 Ω trace (a commonly used trace impedance) place a 33 Ω resistor in series with the clock line, as close to the clock output pin as possible. The nominal impedance of the clock output is 20 Ω .

value of these capacitors is given by the following equation:

Absolute Maximum Ratings

Stresses above the ratings listed below can cause permanent damage to the ICS180-52. These ratings, which are standard values for IDT commercially rated parts, are stress ratings only. Functional operation of the device at these or any other conditions above those indicated in the operational sections of the specifications is not implied. Exposure to absolute maximum rating conditions for extended periods can affect product reliability. Electrical parameters are guaranteed only over the recommended operating temperature range.

| Item | Rating |
|-------------------------------|---------------------|
| Supply Voltage, VDD | 7 V |
| All Inputs and Outputs | -0.5 V to VDD+0.5 V |
| Ambient Operating Temperature | 0 to +70° C |
| Storage Temperature | -65 to +150° C |
| Junction Temperature | 125° C |
| Soldering Temperature | 260° C |

Recommended Operation Conditions

| Parameter | Min. | Typ. | Max. | Units |
|---|--------|------|------|-------|
| Ambient Operating Temperature | 0 | | +70 | ° C |
| Power Supply Voltage (measured in respect to GND) | +3.135 | | +5.5 | V |

PCB Layout Recommendations

For optimum device performance and lowest output phase noise, the following guidelines should be observed.

- 1) The 0.01 μ F decoupling capacitor should be mounted on the component side of the board as close to the VDD pin as possible. No vias should be used between the decoupling capacitor and VDD pin. The PCB trace to VDD pin should be kept as short as possible, as should the PCB trace to the ground via.
- 2) To minimize EMI, the 33 Ω series termination resistor (if needed) should be placed close to the clock output.
- 3) An optimum layout is one with all components on the same side of the board, minimizing vias through other signal layers. Other signal traces should be routed away from the ICS180-52. This includes signal traces just underneath the device, or on layers adjacent to the ground plane layer used by the device.

DC Electrical Characteristics

Unless stated otherwise, **VDD = 3.3 V ±5%**, Ambient Temperature 0 to +70°C

| Parameter | Symbol | Conditions | Min. | Typ. | Max. | Units |
|------------------------|------------------|---|---------|------|-------|-------|
| Operating Voltage | VDD | | 3.135 | | 3.465 | V |
| Supply Current | IDD | No load | | 18 | 32 | mA |
| Input High Voltage | V _{IH} | | 2.4 | | | V |
| Input Low Voltage | V _{IL} | | | | 0.8 | V |
| Output High Voltage | V _{OH} | I _{OH} = -4 mA | VDD-0.4 | | | V |
| Output High Voltage | V _{OH} | I _{OH} = -15 mA | 2.4 | | | V |
| Output Low Voltage | V _{OL} | I _{OL} = 15 mA | | | 0.4 | V |
| Input Capacitance | C _{IN} | | | 5 | 7 | pF |
| Output Impedance | R _{out} | | | 25 | | ohms |
| Input Pull-up Resistor | | | | 500 | | KΩ |
| Power-up Time | | First locked clock cycle after steady power | | | 5 | ms |

Unless stated otherwise, **VDD = 5 V, ±10%**, Ambient Temperature 0 to +70°C

| Parameter | Symbol | Conditions | Min. | Typ. | Max. | Units |
|------------------------|------------------|---|--------|------|---------|-------|
| Operating Voltage | VDD | | 4.5 | 5 | 5.5 | V |
| Supply Current | IDD | No load | | 30 | 50 | mA |
| Input High Voltage | V _{IH} | | 0.7VDD | | | V |
| Input Low Voltage | V _{IL} | | | | 0.15VDD | V |
| Output High Voltage | V _{OH} | I _{OH} = -24 mA | 2.4 | | | V |
| Output Low Voltage | V _{OL} | I _{OL} = 24 mA | | | 0.4 | V |
| Output Impedance | R _{out} | | | 20 | | ohms |
| Input Capacitance | C _{IN} | | | 5 | 7 | pF |
| Input Pull-up Resistor | | | | 500 | | KΩ |
| Power-up Time | | First locked clock cycle after steady power | | | 5 | ms |

AC Electrical Characteristics

Unless stated otherwise, $V_{DD} = 3.3\text{ V} \pm 5\%$ or $5\text{ V} \pm 10\%$, Ambient Temperature 0 to $+70^\circ\text{C}$, $C_L = 15\text{ pf}$

| Parameter | Symbol | Conditions | Min. | Typ. | Max. | Units |
|------------------------------|----------|-----------------------|------|------|------|-------|
| Input/Output Clock Frequency | | | 8 | | 15 | MHz |
| Input Clock Duty Cycle | | Time above $V_{DD}/2$ | 40 | | 60 | % |
| Output Clock Duty Cycle | | Note 1 | 40 | 50 | 60 | % |
| Output Rise Time | t_{OR} | 0.8 to 2.4 V, note 1 | | 2 | 5 | ns |
| Output Fall Time | t_{OF} | 2.4 to 0.8 V, note 1 | | 2 | 5 | ns |
| Jitter | | Cycle-to-cycle | | 250 | 300 | ps |

Note 1: Measured with 15 pF load

Thermal Characteristics

| Parameter | Symbol | Conditions | Min. | Typ. | Max. | Units |
|--|---------------|----------------|------|------|------|--------------------|
| Thermal Resistance Junction to Ambient | θ_{JA} | Still air | | 150 | | $^\circ\text{C/W}$ |
| | θ_{JA} | 1 m/s air flow | | 140 | | $^\circ\text{C/W}$ |
| | θ_{JA} | 3 m/s air flow | | 120 | | $^\circ\text{C/W}$ |
| Thermal Resistance Junction to Case | θ_{JC} | | | 40 | | $^\circ\text{C/W}$ |

Marking Diagram

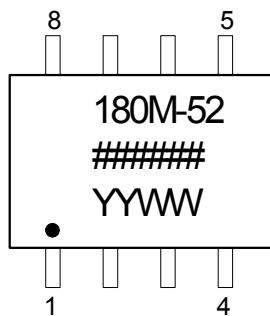

Notes:

- ##### is the lot number.
- YYWW is the last two digits of the year and week that the part was assembled.
- “LF” denotes Pb (lead) free package.
- Bottom marking: country of origin.

Marking Diagram (Pb free)

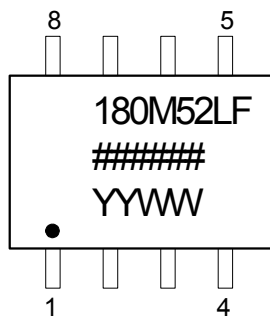

Package Outline and Package Dimensions (8-pin SOIC, 150 Mil. Body)

Package dimensions are kept current with JEDEC Publication No. 95

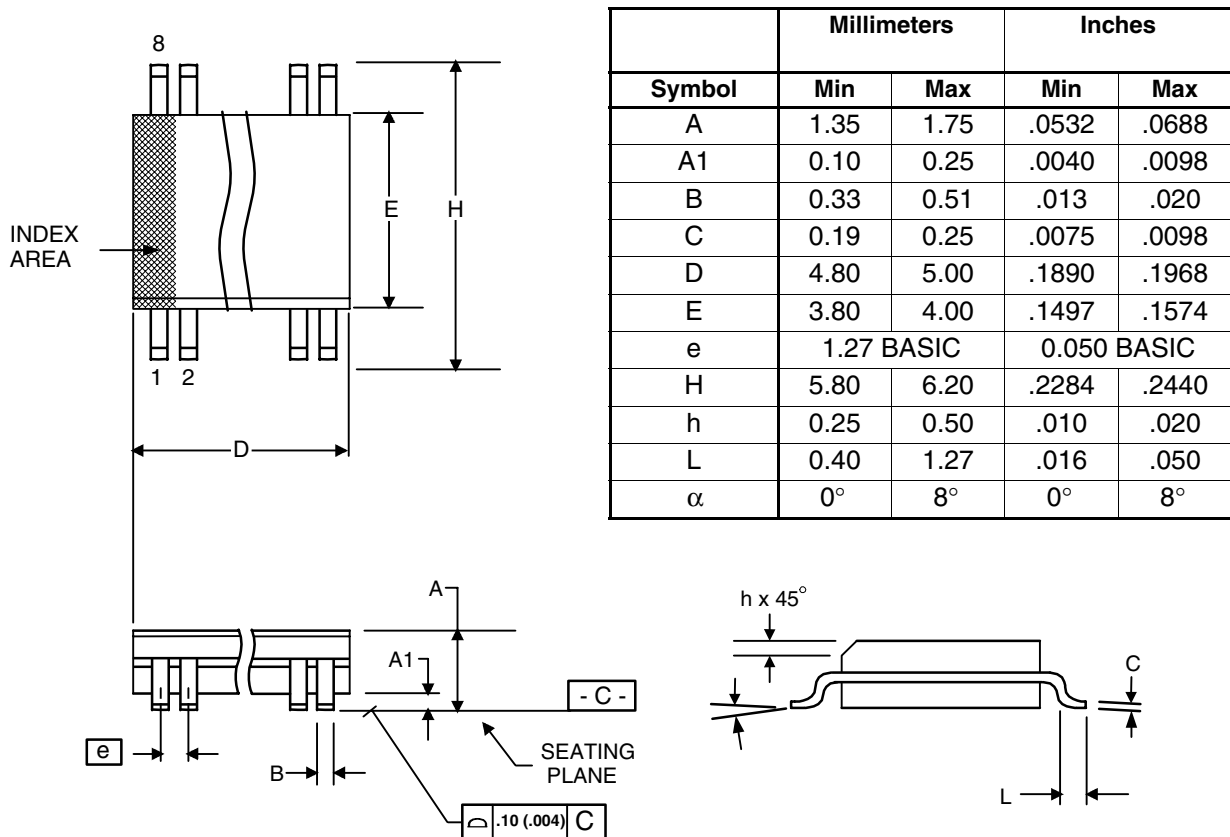

Ordering Information

| Part / Order Number | Marking | Shipping packaging | Package | Temperature |
|---------------------|------------|--------------------|------------|-------------|
| 180M-52* | see page 5 | Tubes | 8-pin SOIC | 0 to +70° C |
| 180M-52T* | | Tape and Reel | 8-pin SOIC | 0 to +70° C |
| 180M-52LF | | Tubes | 8-pin SOIC | 0 to +70° C |
| 180M-52LFT | | Tape and Reel | 8-pin SOIC | 0 to +70° C |

***NOTE: EOL for non-green parts to occur on 5/13/10 per PDN U-09-01**

“LF” denotes Pb free packaging.

While the information presented herein has been checked for both accuracy and reliability, Integrated Circuit Systems (ICS) assumes no responsibility for either its use or for the infringement of any patents or other rights of third parties, which would result from its use. No other circuits, patents, or licenses are implied. This product is intended for use in normal commercial applications. Any other applications such as those requiring extended temperature range, high reliability, or other extraordinary environmental requirements are not recommended without additional processing by ICS. ICS reserves the right to change any circuitry or specifications without notice. ICS does not authorize or warrant any ICS product for use in life support devices or critical medical instruments.

Innovate with IDT and accelerate your future networks. Contact:

www.IDT.com

For Sales

800-345-7015
408-284-8200
Fax: 408-284-2775

For Tech Support

www.idt.com/go/clockhelp

Corporate Headquarters

Integrated Device Technology, Inc.
www.idt.com



www.IDT.com