



Chipsmall Limited consists of a professional team with an average of over 10 year of expertise in the distribution of electronic components. Based in Hongkong, we have already established firm and mutual-benefit business relationships with customers from,Europe,America and south Asia,supplying obsolete and hard-to-find components to meet their specific needs.

With the principle of “Quality Parts,Customers Priority,Honest Operation,and Considerate Service”,our business mainly focus on the distribution of electronic components. Line cards we deal with include Microchip,ALPS,ROHM,Xilinx,Pulse,ON,Everlight and Freescale. Main products comprise IC,Modules,Potentiometer,IC Socket,Relay,Connector.Our parts cover such applications as commercial,industrial, and automotives areas.

We are looking forward to setting up business relationship with you and hope to provide you with the best service and solution. Let us make a better world for our industry!



Contact us

Tel: +86-755-8981 8866 Fax: +86-755-8427 6832

Email & Skype: info@chipsmall.com Web: www.chipsmall.com

Address: A1208, Overseas Decoration Building, #122 Zhenhua RD., Futian, Shenzhen, China



LOW EMI CLOCK GENERATOR

ICS4231-03

Description

The ICS4231-03 generates a low EMI output clock from a clock or crystal input. The device uses IDT's proprietary mix of analog and digital Phase Locked Loop (PLL) technology to spread the frequency spectrum of the output, thereby reducing the frequency amplitude peaks by several dB.

The ICS4231-03 offers four different center and down spread selections. Refer to the MK1714-01/02 for the widest selection of input frequencies and multipliers.

IDT offers a complete line of EMI reducing clock generators. Consult us when you need to remove crystals and oscillators from your board.

Features

- Pin and function compatible to Cypress W42C31-03
- Packaged in 8-pin SOIC (Pb free)
- Provides a spread spectrum output clock
- Accepts a clock or crystal input and provides same frequency dithered output
- Input clock frequency of 10 to 33 MHz
- Peak reduction by 8dB - 14dB typical on 3rd - 19th odd harmonics
- Spread percentage selections of $\pm 1.875\%$, $\pm 1.0\%$, and -2.0%
- Operating voltage of 5V
- Advanced, low-power CMOS process

Block Diagram

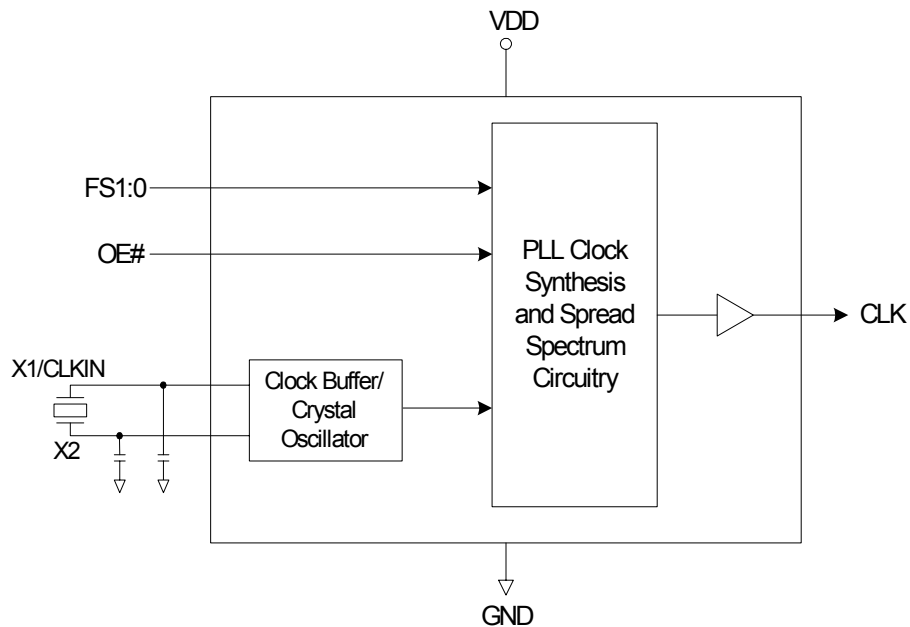

Pin Assignment

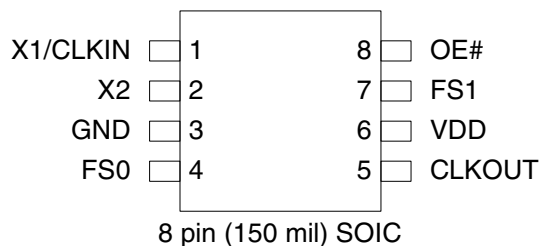

Output Enable Function Table

OE# (Pin 8)	Output Status
0	Running
1	Tri-state

0 = connect to GND

1 = connect directly to VDD

Note: OE# pin has an internal pull-down resistor

Frequency Range and Spread Table

FS1 (Pin 7)	FS0 (Pin 4)	Clock Input Frequency (MHz)	Crystal Input Frequency (MHz)	Spread Amount
0	0	10-20	10-20	±1.875%
0	1	10-20	10-20	±1.0%
1	0	20-33	20-25	±1.875%
1	1	20-33	20-25	-2.0%

Note: FS1:0 have internal pull-up resistors

Pin Descriptions

Pin Number	Pin Name	Pin Type	Pin Description
1	X1/CLKIN	Input	Crystal or Clock Input.
2	X2	Output	Crystal output. Float for a clock input.
3	GND	Power	Connect to ground.
4	FS0	Input	Select pin for input frequency and spread amount. See table above. Internal pull up resistor.
5	CLKOUT	Output	Spread spectrum clock output per table above.
6	VDD	Power	Connect to 5V.
7	FS1	Input	Select pin for input frequency and spread amount. See table above. Internal pull up resistor.
8	OE#	Input	Output Enable. Active Low. See table above. Internal pull-down resistor.

External Components

The ICS4231-03 requires a minimum number of external components for proper operation.

Decoupling Capacitor

A decoupling capacitor of 0.01 μ F must be connected between VDD and GND on pins 6 and 3, as close to these pins as possible. For optimum device performance, the decoupling capacitor should be mounted on the component side of the PCB. Avoid the use of vias in the decoupling circuit.

Series Termination Resistor

When the PCB trace between the clock output and the load is over 1 inch, series termination should be used. To series terminate a 50 Ω trace (a commonly used trace impedance) place a 33 Ω resistor in series with the clock line, as close to the clock output pin as possible. The nominal impedance of the clock output is 20 Ω

value of these capacitors is given by the following equation:

Absolute Maximum Ratings

Stresses above the ratings listed below can cause permanent damage to the ICS4231-03. These ratings, which are standard values for IDT commercially rated parts, are stress ratings only. Functional operation of the device at these or any other conditions above those indicated in the operational sections of the specifications is not implied. Exposure to absolute maximum rating conditions for extended periods can affect product reliability. Electrical parameters are guaranteed only over the recommended operating temperature range.

Item	Rating
Supply Voltage, VDD	7V
All Inputs and Outputs	-0.5V to VDD+0.5V
Ambient Operating Temperature	0 to +70° C
Storage Temperature	-65 to +150° C
Junction Temperature	125° C
Soldering Temperature	260° C

PCB Layout Recommendations

For optimum device performance and lowest output phase noise, the following guidelines should be observed.

- 1) The 0.01 μ F decoupling capacitor should be mounted on the component side of the board as close to the VDD pin as possible. No vias should be used between the decoupling capacitor and VDD pin. The PCB trace to VDD pin should be kept as short as possible, as should the PCB trace to the ground via.
- 2) To minimize EMI the 33 Ω series termination resistor, if needed, should be placed close to the clock output.
- 3) An optimum layout is one with all components on the same side of the board, minimizing vias through other signal layers. Other signal traces should be routed away from the ICS4231-03. This includes signal traces just underneath the device, or on layers adjacent to the ground plane layer used by the device.

DC Electrical Characteristics

Unless stated otherwise, VDD = 5V, $\pm 10\%$, Ambient Temperature 0 to +70° C

Parameter	Symbol	Conditions	Min.	Typ.	Max.	Units
Operating Voltage	VDD		4.5	5	5.5	V
Supply Current	IDD	No load, at 3.3V		18	32	mA
Input High Voltage	V _{IH}		0.7VDD			V
Input Low Voltage	V _{IL}				0.15VDD	V
Output High Voltage	V _{OH}	I _{OH} = -24mA	2.5			V
Output Low Voltage	V _{OL}	I _{OL} = 24mA			0.4	V
Input Capacitance	C _{IN}	All pins except X1, X2		5	7	pF
Load Capacitance		X1, X2, as seen by the xtal, Note 1		17		pF
Output Impedance	R _{out}			20		Ω
Input Pull-Up Resistor				500		K Ω
Power-Up Time		First locked clock cycle after Power Good			5	ms

Note 1: Pins X1 and X2 each have 34 pF capacitance. When used with a crystal, the total combined capacitance as seen by the crystal is 17 pF. If driving X1 with a clock input, the load capacitance will be 34 pF.

AC Electrical Characteristics

Unless stated otherwise, VDD = 5V $\pm 10\%$, Ambient Temperature 0 to +70° C, C_L=15pf

Parameter	Symbol	Conditions	Min.	Typ.	Max.	Units
Input Frequency		Input Clock	10		33	MHz
Output Frequency			10		33	MHz
Input Clock Duty Cycle		Time above VDD/2	40		60	%
Output Clock Duty Cycle		Note 1	45	50	55	%
Output Rise Time	t _{OR}	0.8 to 2.4V, note 1		2	5	ns
Output Fall Time	t _{OF}	2.4 to 0.8V, note 1		2	5	ns
Jitter		cycle-to-cycle			300	ps
Harmonic Reduction			8			dB

Note 1: Measured with 15pF load

Thermal Characteristics

Parameter	Symbol	Conditions	Min.	Typ.	Max.	Units
Thermal Resistance Junction to Ambient	θ_{JA}	Still air		150		$^{\circ}\text{C/W}$
	θ_{JA}	1 m/s air flow		140		$^{\circ}\text{C/W}$
	θ_{JA}	3 m/s air flow		120		$^{\circ}\text{C/W}$
Thermal Resistance Junction to Case	θ_{JC}			40		$^{\circ}\text{C/W}$

Marking Diagram

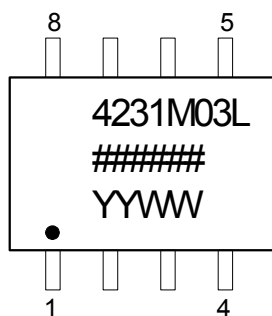

Notes:

1. ##### is the lot number.
2. YYWW is the last two digits of the year and week that the part was assembled.
3. "L" denotes Pb (lead) free package.
4. Bottom marking: country of origin.

Package Outline and Package Dimensions (8 pin SOIC, 150 Mil. Body)

Package dimensions are kept current with JEDEC Publication No. 95

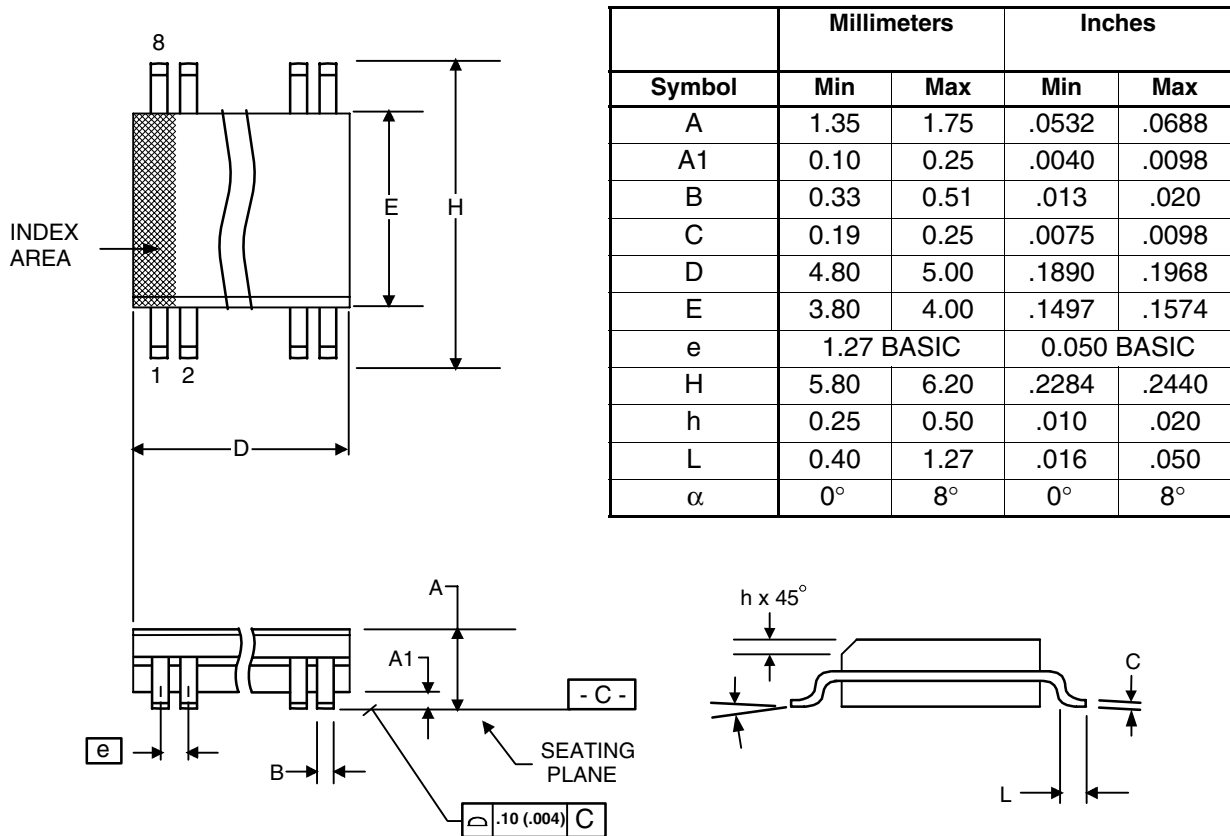

Ordering Information

Part / Order Number	Marking	Shipping packaging	Package	Temperature
4231M-03LF	see page 5	Tubes	8-pin SOIC	0 to +70° C
4231M-03LFT		Tape and Reel	8-pin SOIC	0 to +70° C

“LF” denotes Pb free packaging.

While the information presented herein has been checked for both accuracy and reliability, Integrated Device Technology (IDT) assumes no responsibility for either its use or for the infringement of any patents or other rights of third parties, which would result from its use. No other circuits, patents, or licenses are implied. This product is intended for use in normal commercial applications. Any other applications such as those requiring extended temperature range, high reliability, or other extraordinary environmental requirements are not recommended without additional processing by IDT. IDT reserves the right to change any circuitry or specifications without notice. IDT does not authorize or warrant any IDT product for use in life support devices or critical medical instruments.

Innovate with IDT and accelerate your future networks. Contact:

www.IDT.com

For Sales

800-345-7015
408-284-8200
Fax: 408-284-2775

For Tech Support

www.idt.com/go/clockhelp

Corporate Headquarters

Integrated Device Technology, Inc.
www.idt.com



www.IDT.com