



Chipsmall Limited consists of a professional team with an average of over 10 year of expertise in the distribution of electronic components. Based in Hongkong, we have already established firm and mutual-benefit business relationships with customers from,Europe,America and south Asia,supplying obsolete and hard-to-find components to meet their specific needs.

With the principle of “Quality Parts,Customers Priority,Honest Operation,and Considerate Service”,our business mainly focus on the distribution of electronic components. Line cards we deal with include Microchip,ALPS,ROHM,Xilinx,Pulse,ON,Everlight and Freescale. Main products comprise IC,Modules,Potentiometer,IC Socket,Relay,Connector.Our parts cover such applications as commercial,industrial, and automotives areas.

We are looking forward to setting up business relationship with you and hope to provide you with the best service and solution. Let us make a better world for our industry!



Contact us

Tel: +86-755-8981 8866 Fax: +86-755-8427 6832

Email & Skype: info@chipsmall.com Web: www.chipsmall.com

Address: A1208, Overseas Decoration Building, #122 Zhenhua RD., Futian, Shenzhen, China



QUAD PLL FOR DTV

ICS487-25

Description

The ICS487-25 generates five high-quality, high-frequency clock outputs. It is designed to replace crystals and crystal oscillators in DTV applications. Using IDT's patented Phase Locked Loop (PLL) techniques, the device runs from a lower frequency crystal or clock input.

Because there is zero ppm frequency synthesis error on the audio clocks, the audio will remain locked to the video.

Features

- Packaged in 16-pin TSSOP (Pb-free)
- Replaces multiple crystals and oscillators
- Input crystal or clock frequency of 27 MHz
- Zero ppm frequency synthesis error
- Duty cycle of 45/55
- Operating voltage of 3.3 V
- Advanced, low power CMOS process

Block Diagram

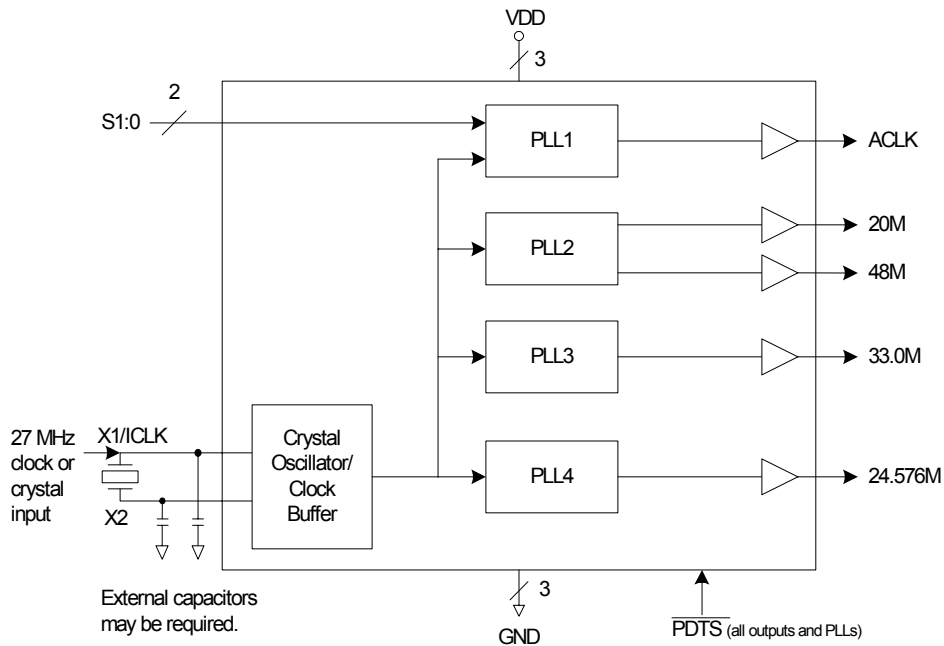

Pin Assignment

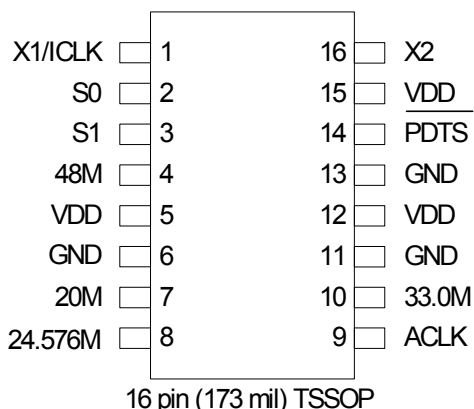

ACLK Output Selection Table

S1	S0	ACLK (MHz)
0	0	18.432
0	1	16.9344
1	0	12.288
1	1	18.432

Note: When S1 and S0 are switched, all other output clocks will remain stable throughout the transition.

Pin Descriptions

Pin Number	Pin Name	Pin Type	Pin Description
1	X1/ICLK	Input	Crystal connection. Connect to 27 MHz crystal or clock input.
2	S0	Input	Select pin 0. Determines ACLK output frequency per table above. Internal pull up resistor.
3	S1	Input	Select pin 1. Determines ACLK output frequency per table above. Internal pull up resistor.
4	48M	Output	48 MHz clock output. Weak internal pull-down when tri-state.
5	VDD	Power	Connect to +3.3 V.
6	GND	Power	Connect to ground.
7	20M	Output	20 MHz clock output. Weak internal pull-down when tri-state.
8	24.576M	Output	24.576 MHz clock output. Weak internal pull-down when tri-state.
9	ACLK	Output	Audio clock output. Determined by table above. Weak internal pull-down when tri-state
10	33.0M	Output	33.0 MHz clock output. Weak internal pull-down when tri-state.
11	GND	Power	Connect to ground.
12	VDD	Power	Connect to +3.3 V.
13	GND	Power	Connect to ground.
14	$\overline{\text{PDTS}}$	Input	Powers down entire chip and tri-states outputs when low. Internal pull-up resistor.
15	VDD	Power	Connect to +3.3 V.
16	X2	Input	Connect to 27 MHz crystal or float for clock input.

External Components

Decoupling Capacitor

As with any high-performance mixed-signal IC, the ICS487-25 must be isolated from system power supply noise to perform optimally.

A decoupling capacitor of 0.01 μ F must be connected between each VDD and the PCB ground plane.

Series Termination Resistor

Clock output traces over one inch should use series termination. To series terminate a 50 Ω trace (a commonly used trace impedance), place a 33 Ω resistor in series with the clock line, as close to the clock output pin as possible. The nominal impedance of the clock output is 20 Ω .

Crystal Load Capacitors

The device crystal connections should include pads for small capacitors from X1 to ground and from X2 to ground. These capacitors are used to adjust the stray capacitance of the board to match the nominally required crystal load capacitance. Because load capacitance can only be increased in this trimming process, it is important to keep stray capacitance to a minimum by using very short PCB traces (and no vias) between the crystal and device. Crystal capacitors must be connected from each of the pins X1 and X2 to ground.

The value (in pF) of these crystal caps should equal (C_L

-6 pF)*2. In this equation, C_L = crystal load capacitance in pF. Example: For a crystal with a 16 pF load capacitance, each crystal capacitor would be 20 pF [(16-6) x 2] = 20.

PCB Layout Recommendations

For optimum device performance and lowest output phase noise, the following guidelines should be observed.

- 1) The 0.01 μ F decoupling capacitors should be mounted on the component side of the board as close to the VDD pin as possible. No vias should be used between the decoupling capacitors and VDD pins. The PCB trace to VDD pins should be kept as short as possible, as should the PCB trace to the ground via.
- 2) The external crystal should be mounted just next to the device with short traces. The X1 and X2 traces should not be routed next to each other with minimum spaces, instead they should be separated and away from other traces.
- 3) To minimize EMI, the 33 Ω series termination resistor (if needed) should be placed close to the clock output.
- 4) An optimum layout is one with all components on the same side of the board, minimizing vias through other signal layers. Other signal traces should be routed away from the ICS487-25. This includes signal traces just underneath the device, or on layers adjacent to the ground plane layer used by the device.

Absolute Maximum Ratings

Stresses above the ratings listed below can cause permanent damage to the ICS487-25. These ratings, which are standard values for IDT commercially rated parts, are stress ratings only. Functional operation of the device at these or any other conditions above those indicated in the operational sections of the specifications is not implied. Exposure to absolute maximum rating conditions for extended periods can affect product reliability. Electrical parameters are guaranteed only over the recommended operating temperature range.

Item	Rating
Supply Voltage, VDD	7 V
All Inputs and Outputs	-0.5 V to VDD+0.5 V
Ambient Operating Temperature	0 to +70 $^{\circ}$ C

Item	Rating
Storage Temperature	-65 to +150° C
Junction Temperature	125° C
Soldering Temperature	260° C

Recommended Operation Conditions

Parameter	Min.	Typ.	Max.	Units
Ambient Operating Temperature	0		+70	° C
Power Supply Voltage (measured in respect to GND)	+3.135	+3.3	+3.465	V

DC Electrical Characteristics

Unless stated otherwise, VDD = 3.3 V ±5%, Ambient Temperature 0 to +70° C

Parameter	Symbol	Conditions	Min.	Typ.	Max.	Units
Operating Voltage	VDD		3.135	3.3	3.465	V
Supply Current	IDD	No load, $\overline{\text{PDT}}\overline{\text{S}}=1$		35		mA
Power Down Current	IDDPD	No load, $\overline{\text{PDT}}\overline{\text{S}}=0$		20		μA
Input High Voltage	V _{IH}		2			V
Input Low Voltage	V _{IL}				0.8	V
Output High Voltage	V _{OH}	I _{OH} = -4 mA	VDD-0.4			V
Output High Voltage	V _{OH}	I _{OH} = -12 mA	2.4			V
Output Low Voltage	V _{OL}	I _{OL} = 12 mA			0.4	V
Short Circuit Current	I _{OS}	Clock outputs		±70		mA
Input Capacitance, inputs	C _{IN}			5		pF
Nominal Output Impedance	Z _{OUT}			20		Ω
Internal Pull-up Resistor	R _{PU}	S1, S0, $\overline{\text{PDT}}\overline{\text{S}}$ pins		360		kΩ
Internal Pull-down Resistor	R _{PD}	Clock outputs		510		kΩ

AC Electrical Characteristics

Unless stated otherwise, $V_{DD} = 3.3\text{ V} \pm 5\%$, Ambient Temperature 0 to $+70^{\circ}\text{C}$

Parameter	Symbol	Conditions	Min.	Typ.	Max.	Units
Input Frequency	f_{IN}			27		MHz
Output Rise Time	t_{OR}	20% to 80%, Note 1		1.2		ns
Output Fall Time	t_{OF}	80% to 20%, Note 1		1.0		ns
Output Clock Duty Cycle		at $V_{DD}/2$, Note 1	45	50	55	%
Absolute Clock Period Jitter		Note 1		± 175		ps
Frequency Synthesis Error		All outputs		0		ppm
Output Enable Time	t_{OE}	$\overline{PDT\overline{S}}$ high to output locked to $\pm 1\%$		250		μs
Output Disable Time	t_{OD}	$\overline{PDT\overline{S}}$ low to tri-state		20		ns
Audio Clock Stabilization Time		Time from a change in S1 or S0 until output stable within $\pm 1\%$		50		μs

Note 1: Measured with a 15 pF load.

Thermal Characteristics

Parameter	Symbol	Conditions	Min.	Typ.	Max.	Units
Thermal Resistance Junction to Ambient	θ_{JA}	Still air		78		$^{\circ}\text{C/W}$
	θ_{JA}	1 m/s air flow		70		$^{\circ}\text{C/W}$
	θ_{JA}	3 m/s air flow		68		$^{\circ}\text{C/W}$
Thermal Resistance Junction to Case	θ_{JC}			37		$^{\circ}\text{C/W}$

Package Outline and Package Dimensions (16-pin TSSOP, 173 Mil. Narrow Body)

Package dimensions are kept current with JEDEC Publication No. 95

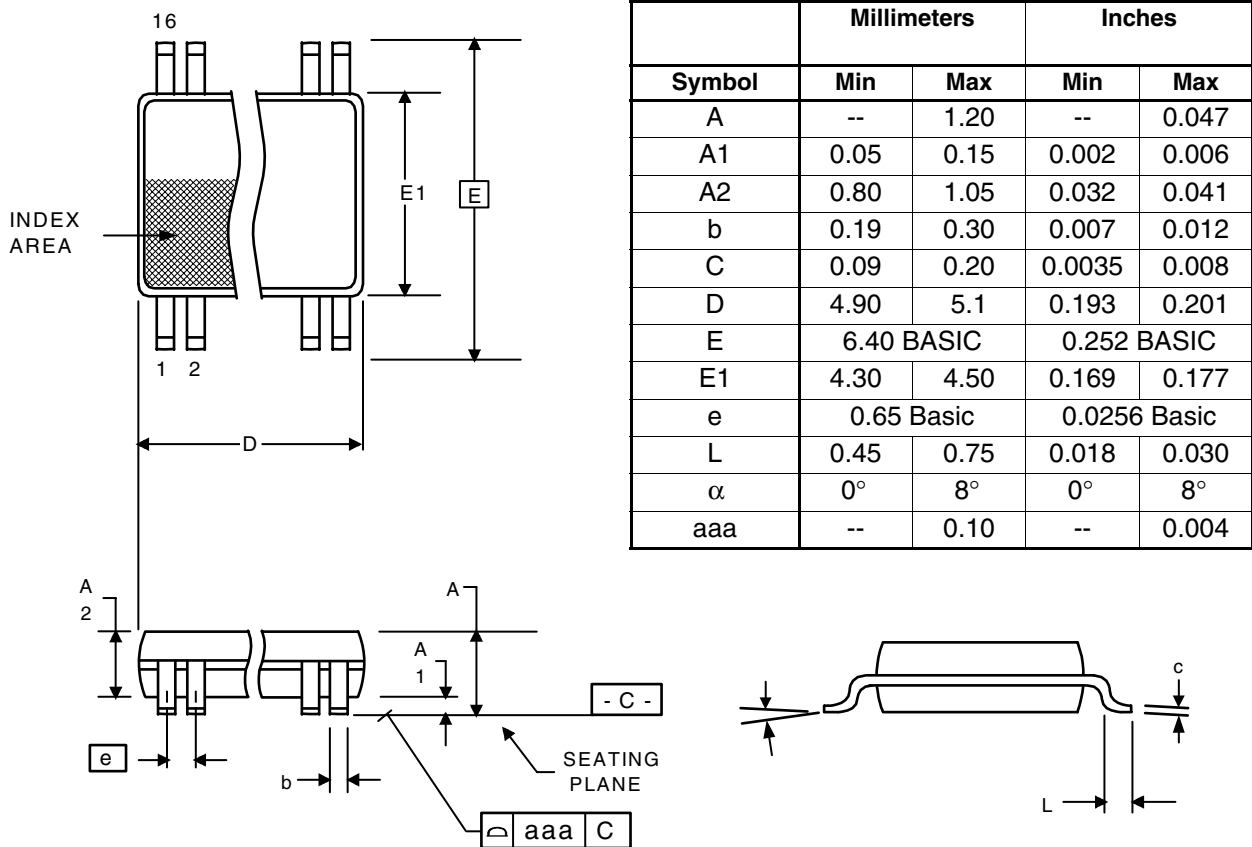

Ordering Information

Part / Order Number	Marking	Shipping Packaging	Package	Temperature
487G-25LF	487G-25LF (1st line)	Tubes	16-pin TSSOP	0 to +70 °C
487G-25LFT	YYWW\$\$ (3rd line)	Tape and Reel	16-pin TSSOP	0 to +70 °C

“LF” suffix to the part number denotes Pb free configuration and RoHS compliant.

While the information presented herein has been checked for both accuracy and reliability, Integrated Device Technology (IDT) assumes no responsibility for either its use or for the infringement of any patents or other rights of third parties, which would result from its use. No other circuits, patents, or licenses are implied. This product is intended for use in normal commercial applications. Any other applications such as those requiring extended temperature range, high reliability, or other extraordinary environmental requirements are not recommended without additional processing by IDT. IDT reserves the right to change any circuitry or specifications without notice. IDT does not authorize or warrant any IDT product for use in life support devices or critical medical instruments.

Innovate with IDT and accelerate your future networks. Contact:

www.IDT.com

For Sales

800-345-7015
408-284-8200
Fax: 408-284-2775

For Tech Support

www.idt.com/go/clockhelp

Corporate Headquarters

Integrated Device Technology, Inc.
www.idt.com



www.IDT.com