



Chipsmall Limited consists of a professional team with an average of over 10 year of expertise in the distribution of electronic components. Based in Hongkong, we have already established firm and mutual-benefit business relationships with customers from,Europe,America and south Asia,supplying obsolete and hard-to-find components to meet their specific needs.

With the principle of “Quality Parts,Customers Priority,Honest Operation,and Considerate Service”,our business mainly focus on the distribution of electronic components. Line cards we deal with include Microchip,ALPS,ROHM,Xilinx,Pulse,ON,Everlight and Freescale. Main products comprise IC,Modules,Potentiometer,IC Socket,Relay,Connector.Our parts cover such applications as commercial,industrial, and automotives areas.

We are looking forward to setting up business relationship with you and hope to provide you with the best service and solution. Let us make a better world for our industry!



Contact us

Tel: +86-755-8981 8866 Fax: +86-755-8427 6832

Email & Skype: info@chipsmall.com Web: www.chipsmall.com

Address: A1208, Overseas Decoration Building, #122 Zhenhua RD., Futian, Shenzhen, China



MULTIPLIER AND ZERO DELAY BUFFER
ICS570-01
Description

The ICS570-01 is a high-performance Zero Delay Buffer (ZDB) which integrates IDT's proprietary mixed signal Phased Lock Loop (PLL) techniques. The zero delay feature means that the rising edge of the input clock aligns with the rising edges of the output clock, giving the appearance of no delay through the device. The device includes an on-chip ROM table with nine different multiplication factors, allowing it to generate many common output frequencies from a single input.

Features

- 8-pin MSOP package (3.00 mm x 3.00 mm body)
- Available in Pb (lead) free package
- Low input to output skew of 300 ps max
- Can recover degraded input clock duty cycle
- Output clock duty cycle of 45/55
- Power Down and Tri-State Mode
- Accepts spread spectrum clock inputs
- Advanced, low power CMOS process
- 3.3 V operation
- Industrial temperature version available

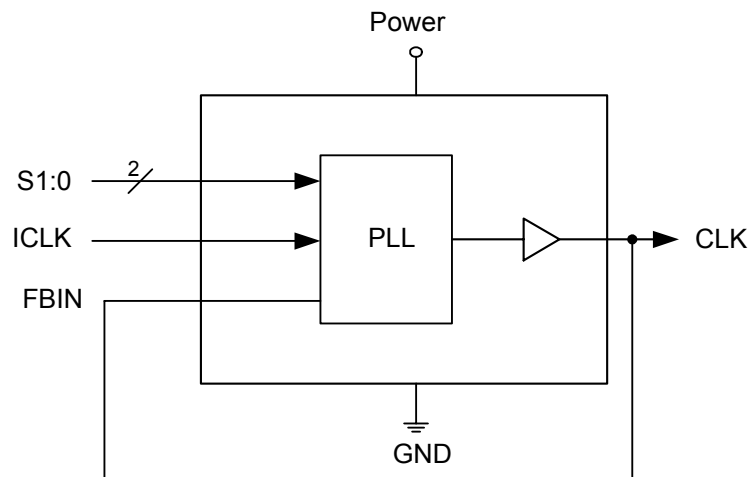
Block Diagram

Pin Assignment

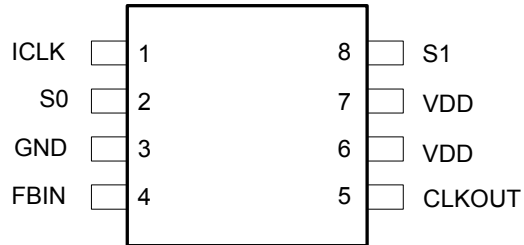

Pin Descriptions

Pin Number	Pin Name	Pin Type	Pin Description
1	ICLK	Input	Clock input.
2	S0	Input	Select pin 0 for output clock. Connect to GND, VDD, or float per multiplier table.
3	GND	Power	Connect to ground.
4	FBIN	Input	Feedback clock input.
5	CLKOUT	Output	Clock output with 5x multiplier.
6	VDD	Power	Connect to 3.3 V supply.
7	VDD	Power	Connect to 3.3 V supply.
8	S1	Input	Select pin 1 for output clock. Connect to GND, VDD, or float per multiplier table.

Clock Multiplier Table

S1	S0	Multiplier	ICLK Range
0	0	4x	7 - 24 MHz
0	M	5.333x	8 - 20 MHz
0	1	5x	7 - 22 MHz
M	0	2.5x	11 - 44 MHz
M	M	2x	13 - 55 MHz
M	1	3.333x	10 - 33 MHz
1	0	6x	7 - 18 MHz
1	M	3x	11 - 37 MHz
1	1	8x	5 - 13 MHz

Note: For selections marked "M", the pin is left floating.

External Components

The ICS570-01 requires a minimum number of external components for proper operation. Decoupling capacitors of 0.01 μF should be connected between VDD and GND (pins 3, 6, and 7), as close to the device as possible. A series termination resistor of 33 Ω may be used on each clock output pin to reduce reflections.

Absolute Maximum Ratings

Stresses above the ratings listed below can cause permanent damage to the ICS570-01. These ratings, which are standard values for IDT commercially rated parts, are stress ratings only. Functional operation of the device at these or any other conditions above those indicated in the operational sections of the specifications is not implied. Exposure to absolute maximum rating conditions for extended periods can affect product reliability. Electrical parameters are guaranteed only over the recommended operating temperature range.

Item	Rating
Supply Voltage, VDD	7 V
All Inputs and Outputs	-0.5 V to VDD+0.5 V
Ambient Operating Temperature, Commercial version	0 to +70° C
Ambient Operating Temperature, Industrial version	-40 to +85° C
Storage Temperature	-65 to +150° C
Junction Temperature	125° C
Soldering Temperature	260° C

Recommended Operation Conditions

Parameter	Min.	Typ.	Max.	Units
Ambient Operating Temperature	-40		+85	° C
Power Supply Voltage (measured in respect to GND)	+3.15	+3.3	+3.45	V

DC Electrical Characteristics

Unless stated otherwise, **VDD = 3.3 V ±5%**, Ambient Temperature -40 to +85° C

Parameter	Symbol	Conditions	Min.	Typ.	Max.	Units
Operating Voltage	VDD		3.15		3.45	V
Operating Current	IDD	VDD=3.3 V		16		mA
Input High Voltage	V _{IH}	ICLK, FBIN	2			V
Input Low Voltage	V _{IL}	ICLK, FBIN			0.8	V
Input High Voltage, mid-level input	V _{IH}	S0, S1	VDD-0.5			V
Input Low Voltage, mid-level input	V _{IL}	S0, S1			0.5	V
Output High Voltage (CMOS High)	V _{OH}	I _{OH} = -4 mA	VDD-0.4			V
Output High Voltage	V _{OH}	I _{OH} = -12 mA	2.4			V
Output Low Voltage	V _{OL}	I _{OL} = 12mA			0.4	V
Short Circuit Current	I _{OS}			±70		mA
Input Capacitance	C _{IN}	ICLK, FBIN, S0, S1		5		pF

AC Electrical Characteristics

Unless stated otherwise, **VDD = 3.3 V ±5%**, Ambient Temperature -40 to +85° C

Parameter	Symbol	Conditions	Min.	Typ.	Max.	Units
Input Frequency, ICLK			See page 2			MHz
Output Clock Frequency						MHz
Input to Feedback Skew					300	ps
Part-to-part Skew					700	ps
Input to Output Jitter		ICLK to FBIN			200	ps
Output Clock Rise Time		20% to 80%, Note 1		1.2	2.5	ns
Output Clock Fall Time		80% to 20%, Note 1		1.2	2.5	ns
Output Clock Duty Cycle		Measured at VDD/2, Note 1	45	50	55	%

Note 1: Measured with a 15 pF load.

Thermal Characteristics

Parameter	Symbol	Conditions	Min.	Typ.	Max.	Units
Thermal Resistance Junction to Ambient	θ _{JA}	Still air		95		°C/W
Thermal Resistance Junction to Case	θ _{JC}			48		°C/W

Package Outline and Package Dimensions (8-pin MSOP, 3.00 mm Body)

Package dimensions are kept current with JEDEC Publication No. 95

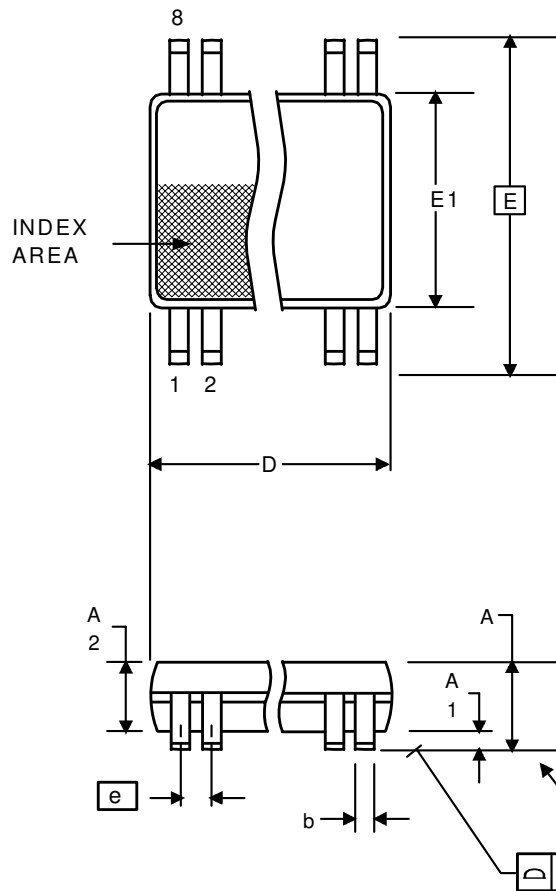

Symbol	Millimeters		Inches*	
	Min	Max	Min	Max
A	--	1.10	--	0.043
A1	0	0.15	0	0.006
A2	0.79	0.97	0.031	0.038
b	0.22	0.38	0.008	0.015
C	0.08	0.23	0.003	0.009
D	3.00 BASIC		0.118 BASIC	
E	4.90 BASIC		0.193 BASIC	
E1	3.00 BASIC		0.118 BASIC	
e	0.65 Basic		0.0256 Basic	
L	0.40	0.80	0.016	0.032
α	0°	8°	0°	8°
aaa	-	0.10	-	0.004

*For reference only. Controlling dimensions in mm.

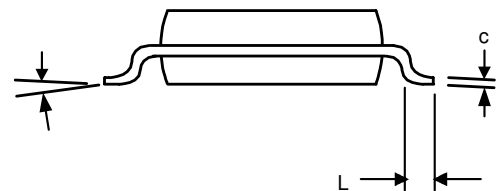

Ordering Information

Part / Order Number	Marking	Shipping Packaging	Package	Temperature
ICS570GI-01LF	GI1L	Tubes	8-pin MSOP	-40 to +85° C
ICS570GI-01LFT	GI1L	Tape and Reel	8-pin MSOP	-40 to +85° C

Parts that are ordered with a "LF" suffix to the part number are the Pb-Free configuration and are RoHS compliant.

While the information presented herein has been checked for both accuracy and reliability, Integrated Device Technology (IDT) assumes no responsibility for either its use or for the infringement of any patents or other rights of third parties, which would result from its use. No other circuits, patents, or licenses are implied. This product is intended for use in normal commercial applications. Any other applications such as those requiring extended temperature range, high reliability, or other extraordinary environmental requirements are not recommended without additional processing by IDT. IDT reserves the right to change any circuitry or specifications without notice. IDT does not authorize or warrant any IDT product for use in life support devices or critical medical instruments.

Revision History

Rev.	Originator	Date	Description of Change
A	K. Beckmeyer	01/25/06	New device/datasheet; Preliminary release.
B	J. Sarma	07/27/06	Added marking information; added new document format; released from Preliminary to final.

Innovate with IDT and accelerate your future networks. Contact:

www.IDT.com

For Sales

800-345-7015
408-284-8200
Fax: 408-284-2775

For Tech Support

www.idt.com/go/clockhelp

Corporate Headquarters

Integrated Device Technology, Inc.
www.idt.com



www.IDT.com