



Chipsmall Limited consists of a professional team with an average of over 10 year of expertise in the distribution of electronic components. Based in Hongkong, we have already established firm and mutual-benefit business relationships with customers from,Europe,America and south Asia,supplying obsolete and hard-to-find components to meet their specific needs.

With the principle of “Quality Parts,Customers Priority,Honest Operation,and Considerate Service”,our business mainly focus on the distribution of electronic components. Line cards we deal with include Microchip,ALPS,ROHM,Xilinx,Pulse,ON,Everlight and Freescale. Main products comprise IC,Modules,Potentiometer,IC Socket,Relay,Connector.Our parts cover such applications as commercial,industrial, and automotives areas.

We are looking forward to setting up business relationship with you and hope to provide you with the best service and solution. Let us make a better world for our industry!



Contact us

Tel: +86-755-8981 8866 Fax: +86-755-8427 6832

Email & Skype: info@chipsmall.com Web: www.chipsmall.com

Address: A1208, Overseas Decoration Building, #122 Zhenhua RD., Futian, Shenzhen, China





GENERAL DESCRIPTION

The ICS83905 is a low skew, 1-to-6 LVCMOS / LVTTTL Fanout Buffer and a member of the HiPerClockS™ family of High Performance Clock Solutions from ICS. The low impedance LVCMOS/ LVTTTL outputs are designed to drive 50Ω series or parallel terminated transmission lines. The effective fanout can be increased from 6 to 12 by utilizing the ability of the outputs to drive two series terminated lines.

The ICS83905 is characterized at full 3.3V, 2.5V, and 1.8V, mixed 3.3V/2.5V, 3.3V/1.8V and 2.5V/1.8V output operating supply mode. Guaranteed output and part-to-part skew characteristics along with the 1.8V output capabilities makes the ICS83905 ideal for high performance, single ended applications that also require a limited output voltage.

FEATURES

- 6 LVCMOS / LVTTTL outputs
- Outputs able to drive 12 series terminated lines
- Crystal oscillator interface
- Crystal input frequency range: 10MHz to 40MHz
- Output skew: 80ps (maximum)
- 5V tolerant enable inputs
- Synchronous output enables
- Operating power supply modes:
Full 3.3V, 2.5V and 1.8V,
mixed 3.3V core/2.5V output operating supply,
mixed 3.3V core/1.8V output operating supply,
mixed 2.5V core/1.8V output operating supply
- 0°C to 70°C ambient operating temperature
- Lead-Free package fully RoHS compliant
- Industrial version available upon request

BLOCK DIAGRAM

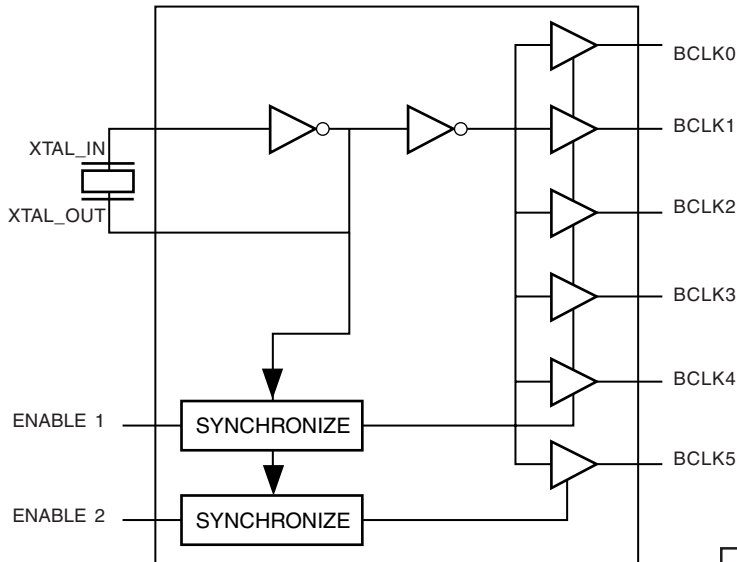

PIN ASSIGNMENTS

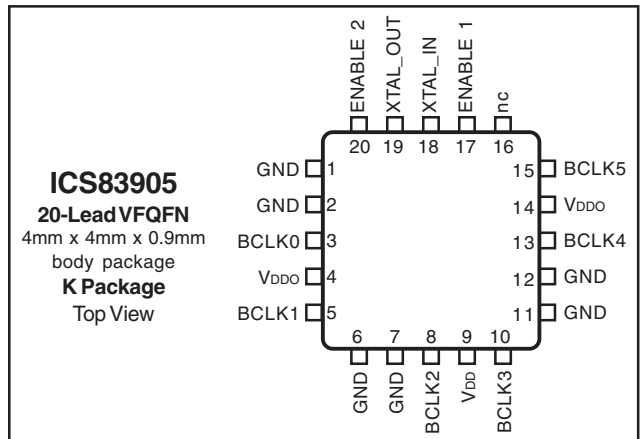
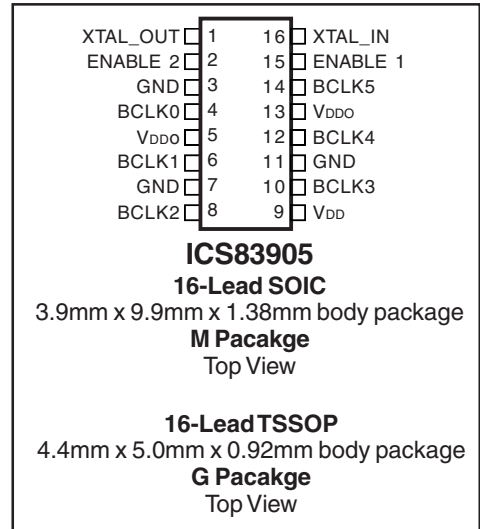



TABLE 1. PIN DESCRIPTIONS

Name	Type	Description
XTAL_OUT	Output	Crystal oscillator interface. XTAL_OUT is the output.
XTAL_IN	Input	Crystal oscillator interface. XTAL_IN is the input.
ENABLE 1, ENABLE 2	Input	Clock enable. LVCMOS / LVTTTL interface levels. See Table 3.
BCLK0, BCLK1, BCLK2, BCLK3, BCLK4, BCLK5	Output	Clock outputs. LVCMOS / LVTTTL interface levels.
GND	Power	Power supply ground.
V _{DD}	Power	Core supply pin.
V _{DDO}	Power	Output supply pin.
n/c	Unused	No connect.

TABLE 2. PIN CHARACTERISTICS

Symbol	Parameter	Test Conditions	Minimum	Typical	Maximum	Units
C _{IN}	Input Capacitance			4		pF
C _{PD}	Power Dissipation Capacitance (per output)	V _{DDO} = 3.465V			19	pF
		V _{DDO} = 2.625V			18	pF
		V _{DDO} = 2V			16	pF
R _{OUT}	Output Impedance	V _{DDO} = 3.3V ± 5%		7		Ω
		V _{DDO} = 2.5V ± 5%		7		Ω
		V _{DDO} = 1.8V ± 0.2V		10		Ω

TABLE 3. CLOCK ENABLE FUNCTION TABLE

Control Inputs		Outputs	
ENABLE 1	ENABLE 2	BCLK0:BCLK4	BCLK5
0	0	LOW	LOW
0	1	LOW	Toggling
1	0	Toggling	LOW
1	1	Toggling	Toggling



ABSOLUTE MAXIMUM RATINGS

Supply Voltage, V_{DD}	4.6V
Inputs, V_I	-0.5V to $V_{DD} + 0.5V$
Outputs, V_O	-0.5V to $V_{DDO} + 0.5V$
Package Thermal Impedance, θ_{JA}	
16 Lead SOIC package	78.8°C/W (0 mps)
16 Lead TSSOP package	89°C/W (0 lfpm)
20 Lead VFQFN package	38.5°C/W (0 mps)
Storage Temperature, T_{STG}	-65°C to 150°C

NOTE: Stresses beyond those listed under Absolute Maximum Ratings may cause permanent damage to the device. These ratings are stress specifications only. Functional operation of product at these conditions or any conditions beyond those listed in the *DC Characteristics* or *AC Characteristics* is not implied. Exposure to absolute maximum rating conditions for extended periods may affect product reliability.

TABLE 4A. POWER SUPPLY DC CHARACTERISTICS, $V_{DD} = V_{DDO} = 3.3V \pm 5\%$, $T_A = 0^\circ C$ TO $70^\circ C$

Symbol	Parameter	Test Conditions	Minimum	Typical	Maximum	Units
V_{DD}	Core Supply Voltage		3.135	3.3	3.465	V
V_{DDO}	Output Supply Voltage		3.135	3.3	3.465	V
I_{DD}	Power Supply Current	ENABLE 1:2 = 00			10	mA
I_{DDO}	Output Supply Current	ENABLE 1:2 = 00			5	mA

TABLE 4B. POWER SUPPLY DC CHARACTERISTICS, $V_{DD} = V_{DDO} = 2.5V \pm 5\%$, $T_A = 0^\circ C$ TO $70^\circ C$

Symbol	Parameter	Test Conditions	Minimum	Typical	Maximum	Units
V_{DD}	Core Supply Voltage		2.375	2.5	2.625	V
V_{DDO}	Output Supply Voltage		2.375	2.5	2.625	V
I_{DD}	Power Supply Current	ENABLE 1:2 = 00			8	mA
I_{DDO}	Output Supply Current	ENABLE 1:2 = 00			4	mA

TABLE 4C. POWER SUPPLY DC CHARACTERISTICS, $V_{DD} = V_{DDO} = 1.8V \pm 0.2V$, $T_A = 0^\circ C$ TO $70^\circ C$

Symbol	Parameter	Test Conditions	Minimum	Typical	Maximum	Units
V_{DD}	Core Supply Voltage		1.6	1.8	2.0	V
V_{DDO}	Output Supply Voltage		1.6	1.8	2.0	V
I_{DD}	Power Supply Current	ENABLE 1:2 = 00			5	mA
I_{DDO}	Output Supply Current	ENABLE 1:2 = 00			3	mA

TABLE 4D. POWER SUPPLY DC CHARACTERISTICS, $V_{DD} = 3.3V \pm 5\%$, $V_{DDO} = 2.5V \pm 5\%$, $T_A = 0^\circ C$ TO $70^\circ C$

Symbol	Parameter	Test Conditions	Minimum	Typical	Maximum	Units
V_{DD}	Core Supply Voltage		3.135	3.3	3.465	V
V_{DDO}	Output Supply Voltage		2.375	2.5	2.625	V
I_{DD}	Power Supply Current	ENABLE 1:2 = 00			10	mA
I_{DDO}	Output Supply Current	ENABLE 1:2 = 00			4	mA



TABLE 4E. POWER SUPPLY DC CHARACTERISTICS, $V_{DD} = 3.3V \pm 5\%$, $V_{DDO} = 1.8V \pm 0.2V$, $T_A = 0^\circ C$ TO $70^\circ C$

Symbol	Parameter	Test Conditions	Minimum	Typical	Maximum	Units
V_{DD}	Core Supply Voltage		3.135	3.3	3.465	V
V_{DDO}	Output Supply Voltage		1.6	1.8	2.0	V
I_{DD}	Power Supply Current	ENABLE 1:2 = 00			10	mA
I_{DDO}	Output Supply Current	ENABLE 1:2 = 00			3	mA

TABLE 4F. POWER SUPPLY DC CHARACTERISTICS, $V_{DD} = 2.5V \pm 5\%$, $V_{DDO} = 1.8V \pm 0.2V$, $T_A = 0^\circ C$ TO $70^\circ C$

Symbol	Parameter	Test Conditions	Minimum	Typical	Maximum	Units
V_{DD}	Core Supply Voltage		2.375	2.5	2.625	V
V_{DDO}	Output Supply Voltage		1.6	1.8	2.0	V
I_{DD}	Power Supply Current	ENABLE 1:2 = 00			8	mA
I_{DDO}	Output Supply Current	ENABLE 1:2 = 00			3	mA

TABLE 4G. LVCMOS/LVTTTL DC CHARACTERISTICS, $T_A = 0^\circ C$ TO $70^\circ C$

Symbol	Parameter	Test Conditions	Minimum	Typical	Maximum	Units
V_{IH}	Input High Voltage	ENABLE 1, ENABLE 2 $V_{DD} = 3.3V \pm 5\%$	2		$V_{DD} + 0.3$	V
		$V_{DD} = 2.5V \pm 5\%$	1.7		$V_{DD} + 0.3$	V
		$V_{DD} = 1.8V \pm 0.2V$	$0.65 \cdot V_{DD}$		$V_{DD} + 0.3$	V
V_{IL}	Input Low Voltage	ENABLE 1, ENABLE 2 $V_{DD} = 3.3V \pm 5\%$	-0.3		0.8	V
		$V_{DD} = 2.5V \pm 5\%$	-0.3		0.7	V
		$V_{DD} = 1.8V \pm 0.2V$	-0.3		$0.35 \cdot V_{DD}$	V
V_{OH}	Output High Voltage	$V_{DDO} = 3.3V \pm 5\%$; NOTE 1	2.6			V
		$V_{DDO} = 2.5V \pm 5\%$; $I_{OH} = -1mA$	2			V
		$V_{DDO} = 2.5V \pm 5\%$; NOTE 1	1.8			V
		$V_{DDO} = 1.8V \pm 0.2V$; NOTE 1	$V_{DDO} - 0.3$			V
V_{OL}	Output Low Voltage	$V_{DDO} = 3.3V \pm 5\%$; NOTE 1			0.5	V
		$V_{DDO} = 2.5V \pm 5\%$; $I_{OL} = 1mA$			0.4	V
		$V_{DDO} = 2.5V \pm 5\%$; NOTE 1			0.45	V
		$V_{DDO} = 1.8V \pm 0.2V$; NOTE 1			0.35	V

NOTE 1: Outputs terminated with 50Ω to $V_{DDO}/2$. See Parameter Measurement section, "Load Test Circuit" diagrams.

TABLE 5. CRYSTAL CHARACTERISTICS

Parameter	Test Conditions	Minimum	Typical	Maximum	Units
Mode of Oscillation		Fundamental			
Frequency		10		40	MHz
Equivalent Series Resistance (ESR)				50	Ω
Shunt Capacitance				7	pF
Drive Level				1	mW



TABLE 6A. AC CHARACTERISTICS, $V_{DD} = V_{DDO} = 3.3V \pm 5\%$, $T_A = 0^\circ C$ TO $70^\circ C$

Symbol	Parameter	Test Conditions	Minimum	Typical	Maximum	Units
f_{MAX}	Output Frequency	Using External Crystal	10		40	MHz
		Using External Clock Source	DC		100	MHz
odc	Output Duty Cycle		48		52	%
$t_{sk(o)}$	Output Skew; NOTE 1, 3				80	ps
t_R/t_F	Output Rise/Fall Time	20% to 80%	200		800	ps
t_{EN}	Output Enable Time; NOTE 2	ENABLE 1			4	cycles
		ENABLE 2			4	cycles
t_{DIS}	Output Disable Time; NOTE 2	ENABLE 1			4	cycles
		ENABLE 2			4	cycles

All parameters measured at $f \leq f_{MAX}$ using a crystal input unless noted otherwise.

Terminated at 50Ω to $V_{DDO}/2$.

NOTE 1: Defined as skew between outputs at the same supply voltage and with equal load conditions. Measured at $V_{DDO}/2$.

NOTE 2: These parameters are guaranteed by characterization. Not tested in production.

NOTE 3: This parameter is defined in accordance with JEDEC Standard 65.

TABLE 6B. AC CHARACTERISTICS, $V_{DD} = V_{DDO} = 2.5V \pm 5\%$, $T_A = 0^\circ C$ TO $70^\circ C$

Symbol	Parameter	Test Conditions	Minimum	Typical	Maximum	Units
f_{MAX}	Output Frequency	Using External Crystal	10		40	MHz
		Using External Clock Source	DC		100	MHz
odc	Output Duty Cycle		47		53	%
$t_{sk(o)}$	Output Skew; NOTE 1, 3				80	ps
t_R/t_F	Output Rise/Fall Time	20% to 80%	200		800	ps
t_{EN}	Output Enable Time; NOTE 2	ENABLE 1			4	cycles
		ENABLE 2			4	cycles
t_{DIS}	Output Disable Time; NOTE 2	ENABLE 1			4	cycles
		ENABLE 2			4	cycles

All parameters measured at $f \leq f_{MAX}$ using a crystal input unless noted otherwise.

Terminated at 50Ω to $V_{DDO}/2$.

NOTE 1: Defined as skew between outputs at the same supply voltage and with equal load conditions. Measured at $V_{DDO}/2$.

NOTE 2: These parameters are guaranteed by characterization. Not tested in production.

NOTE 3: This parameter is defined in accordance with JEDEC Standard 65.



TABLE 6C. AC CHARACTERISTICS, $V_{DD} = V_{DDO} = 1.8V \pm 0.2V$, $T_A = 0^\circ C$ TO $70^\circ C$

Symbol	Parameter	Test Conditions	Minimum	Typical	Maximum	Units
f_{MAX}	Output Frequency	Using External Crystal	10		40	MHz
		Using External Clock Source	DC		100	MHz
odc	Output Duty Cycle		47		53	%
$t_{sk(o)}$	Output Skew; NOTE 1, 3				80	ps
t_R/t_F	Output Rise/Fall Time	20% to 80%	200		900	ps
t_{EN}	Output Enable Time; NOTE 2	ENABLE 1			4	cycles
		ENABLE 2			4	cycles
t_{DIS}	Output Disable Time; NOTE 2	ENABLE 1			4	cycles
		ENABLE 2			4	cycles

All parameters measured at $f \leq f_{MAX}$ using a crystal input unless noted otherwise.

Terminated at 50Ω to $V_{DDO}/2$.

NOTE 1: Defined as skew between outputs at the same supply voltage and with equal load conditions. Measured at $V_{DDO}/2$.

NOTE 2: These parameters are guaranteed by characterization. Not tested in production.

NOTE 3: This parameter is defined in accordance with JEDEC Standard 65.

TABLE 6D. AC CHARACTERISTICS, $V_{DD} = 3.3V \pm 5\%$, $V_{DDO} = 2.5V \pm 5\%$, $T_A = 0^\circ C$ TO $70^\circ C$

Symbol	Parameter	Test Conditions	Minimum	Typical	Maximum	Units
f_{MAX}	Output Frequency	Using External Crystal	10		40	MHz
		Using External Clock Source	DC		100	MHz
odc	Output Duty Cycle		48		52	%
$t_{sk(o)}$	Output Skew; NOTE 1, 3				80	ps
t_R/t_F	Output Rise/Fall Time	20% to 80%	200		800	ps
t_{EN}	Output Enable Time; NOTE 2	ENABLE 1			4	cycles
		ENABLE 2			4	cycles
t_{DIS}	Output Disable Time; NOTE 2	ENABLE 1			4	cycles
		ENABLE 2			4	cycles

All parameters measured at $f \leq f_{MAX}$ using a crystal input unless noted otherwise.

Terminated at 50Ω to $V_{DDO}/2$.

NOTE 1: Defined as skew between outputs at the same supply voltage and with equal load conditions. Measured at $V_{DDO}/2$.

NOTE 2: These parameters are guaranteed by characterization. Not tested in production.

NOTE 3: This parameter is defined in accordance with JEDEC Standard 65.



TABLE 6E. AC CHARACTERISTICS, $V_{DD} = 3.3V \pm 5\%$, $V_{DDO} = 1.8V \pm 0.2V$, $T_A = 0^\circ C$ TO $70^\circ C$

Symbol	Parameter	Test Conditions	Minimum	Typical	Maximum	Units
f_{MAX}	Output Frequency	Using External Crystal	10		40	MHz
		Using External Clock Source	DC		100	MHz
odc	Output Duty Cycle		48		52	%
$t_{sk(o)}$	Output Skew; NOTE 1, 3				80	ps
t_R/t_F	Output Rise/Fall Time	20% to 80%	200		900	ps
t_{EN}	Output Enable Time; NOTE 2	ENABLE 1			4	cycles
		ENABLE 2			4	cycles
t_{DIS}	Output Disable Time; NOTE 2	ENABLE 1			4	cycles
		ENABLE 2			4	cycles

All parameters measured at $f \leq f_{MAX}$ using a crystal input unless noted otherwise.
Terminated at 50Ω to $V_{DDO}/2$.

NOTE 1: Defined as skew between outputs at the same supply voltage and with equal load conditions. Measured at $V_{DDO}/2$.

NOTE 2: These parameters are guaranteed by characterization. Not tested in production.

NOTE 3: This parameter is defined in accordance with JEDEC Standard 65.

TABLE 6F. AC CHARACTERISTICS, $V_{DD} = 2.5V \pm 5\%$, $V_{DDO} = 1.8V \pm 0.2V$, $T_A = 0^\circ C$ TO $70^\circ C$

Symbol	Parameter	Test Conditions	Minimum	Typical	Maximum	Units
f_{MAX}	Output Frequency	Using External Crystal	10		40	MHz
		Using External Clock Source	DC		100	MHz
odc	Output Duty Cycle		47		53	%
$t_{sk(o)}$	Output Skew; NOTE 1, 3				80	ps
t_R/t_F	Output Rise/Fall Time	20% to 80%	200		900	ps
t_{EN}	Output Enable Time; NOTE 2	ENABLE 1			4	cycles
		ENABLE 2			4	cycles
t_{DIS}	Output Disable Time; NOTE 2	ENABLE 1			4	cycles
		ENABLE 2			4	cycles

All parameters measured at $f \leq f_{MAX}$ using a crystal input unless noted otherwise.

Terminated at 50Ω to $V_{DDO}/2$.

NOTE 1: Defined as skew between outputs at the same supply voltage and with equal load conditions. Measured at $V_{DDO}/2$.

NOTE 2: These parameters are guaranteed by characterization. Not tested in production.

NOTE 3: This parameter is defined in accordance with JEDEC Standard 65.



PARAMETER MEASUREMENT INFORMATION

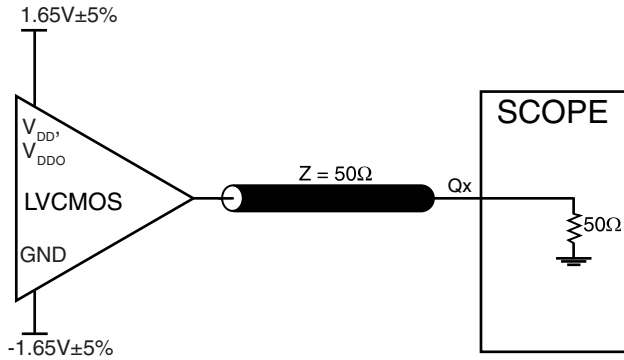

3.3V CORE/3.3V OUTPUT LOAD AC TEST CIRCUIT

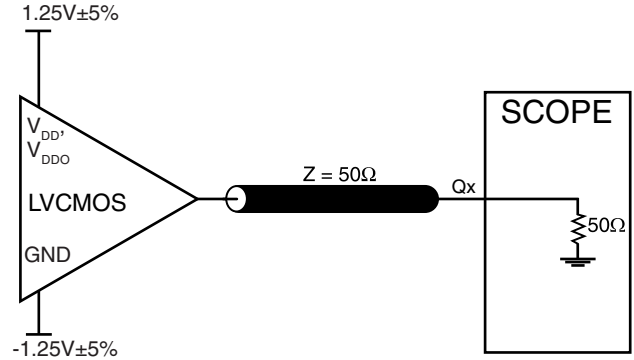

2.5V CORE/2.5V OUTPUT LOAD AC TEST CIRCUIT

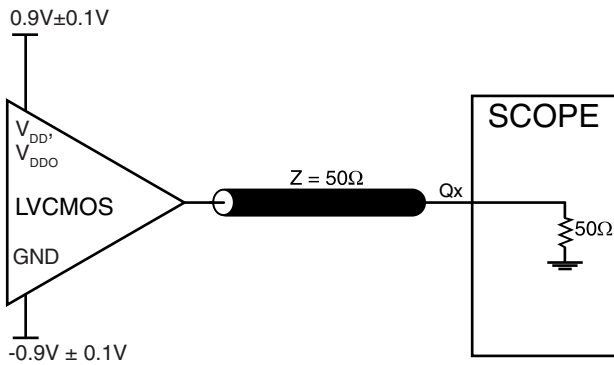

1.8V CORE/1.8V OUTPUT LOAD AC TEST CIRCUIT

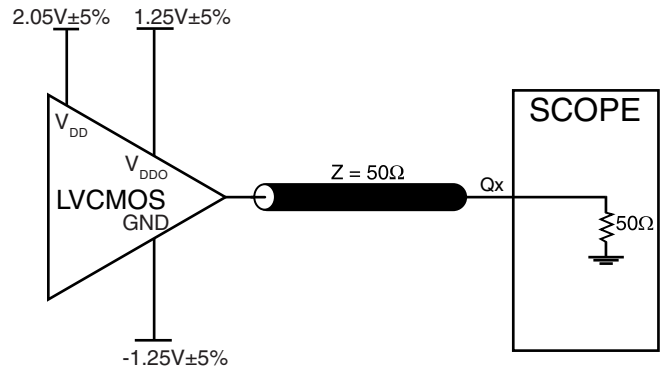

3.3V CORE/2.5V OUTPUT LOAD AC TEST CIRCUIT

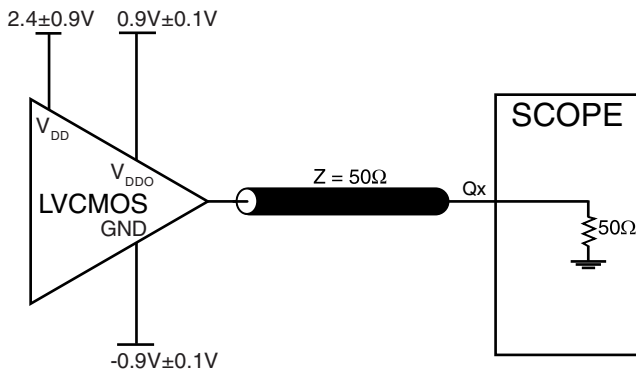

3.3V CORE/1.8V OUTPUT LOAD AC TEST CIRCUIT

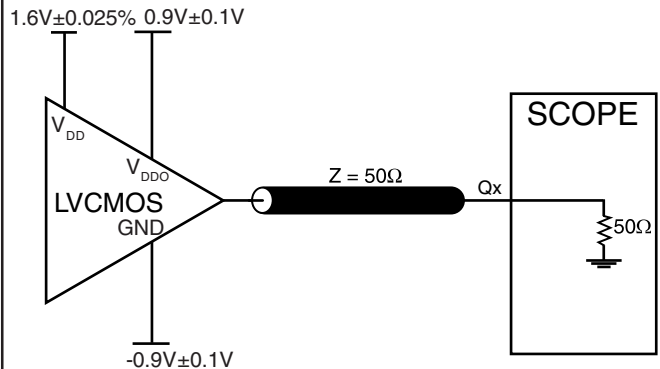

2.5 CORE/1.8V OUTPUT LOAD AC TEST CIRCUIT

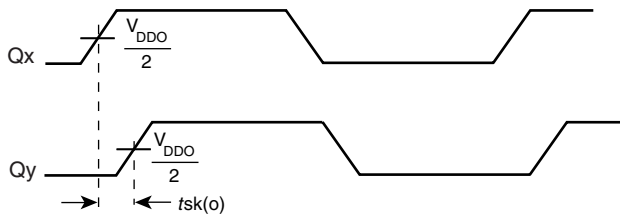

OUTPUT SKEW

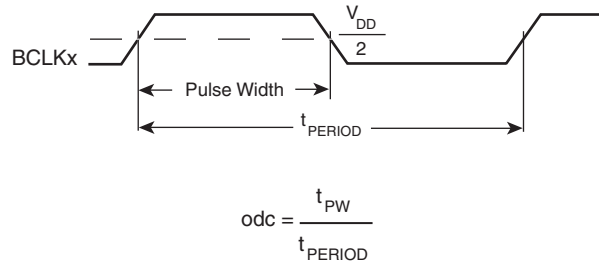

OUTPUT DUTY CYCLE/PULSE WIDTH/PERIOD

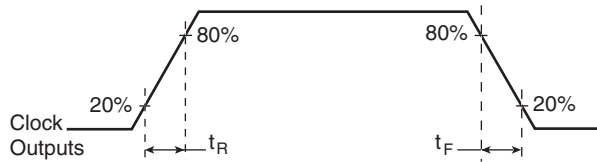

OUTPUT RISE/FALL TIME



RELIABILITY INFORMATION

TABLE 7A. θ_{JA} VS. AIR FLOW TABLE FOR 16 LEAD SOIC

θ_{JA} by Velocity (Meters per Second)			
	0	1	2
Multi-Layer PCB, JEDEC Standard Test Boards	78.8°C/W	71.1°C/W	66.2°C/W

TABLE 7B. θ_{JA} VS. AIR FLOW TABLE FOR 16 LEAD TSSOP

θ_{JA} by Velocity (Linear Feet per Minute)			
	0	200	500
Single-Layer PCB, JEDEC Standard Test Boards	137.1°C/W	118.2°C/W	106.8°C/W
Multi-Layer PCB, JEDEC Standard Test Boards	89.0°C/W	81.8°C/W	78.1°C/W

NOTE: Most modern PCB designs use multi-layered boards. The data in the second row pertains to most designs.

TABLE 7C. θ_{JA} VS. AIR FLOW TABLE FOR 20 LEAD VFQFN

θ_{JA} by Velocity (Meters per Second)			
	0	1	2.5
Single-Layer PCB, JEDEC Standard Test Boards	141.7°C/W	126°C/W	116.9°C/W
Multi-Layer PCB, JEDEC Standard Test Boards	38.5°C/W	35°C/W	33.4°C/W

NOTE: Most modern PCB designs use multi-layered boards. The data in the second row pertains to most designs.

TRANSISTOR COUNT

The transistor count for ICS83905 is: 339

Pin compatible to MPC905



PACKAGE OUTLINE - M SUFFIX FOR 16 LEAD SOIC

PACKAGE OUTLINE - G SUFFIX FOR 16 LEAD TSSOP

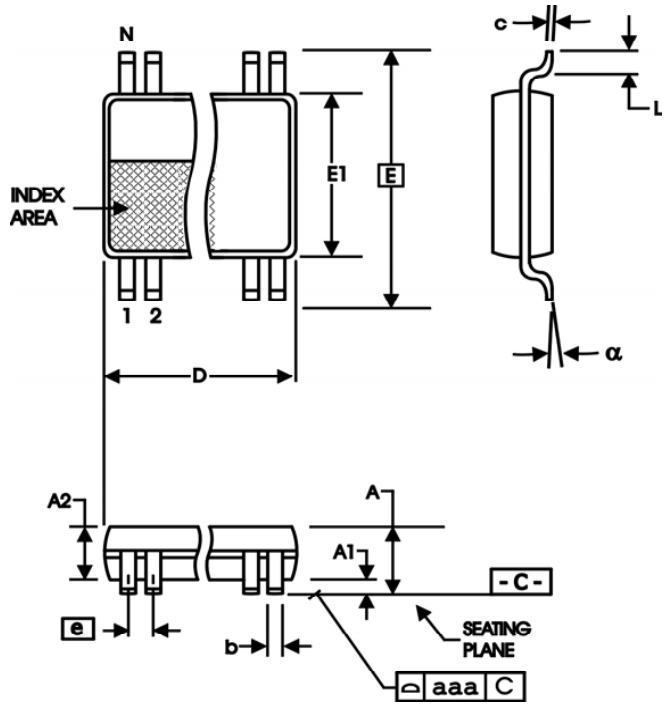
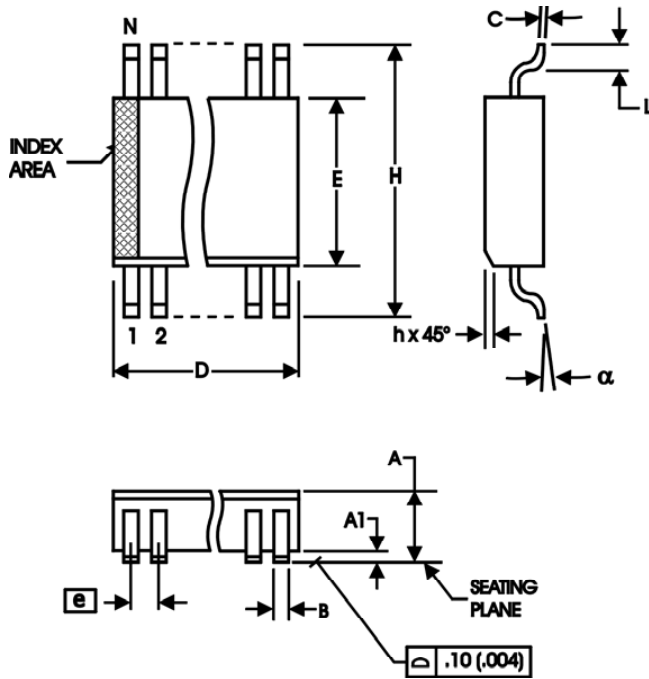

TABLE 8A. PACKAGE DIMENSIONS FOR 16 LEAD SOIC

SYMBOL	Millimeters	
	MINIMUM	MAXIMUM
N	16	
A	1.35	1.75
A1	0.10	0.25
B	0.33	0.51
C	0.19	0.25
D	9.80	10.00
E	3.80	4.00
e	1.27 BASIC	
H	5.80	6.20
h	0.25	0.50
L	0.40	1.27
α	0°	8°

Reference Document: JEDEC Publication 95, MS-012

TABLE 8B. PACKAGE DIMENSIONS FOR TSSOP

SYMBOL	Millimeters	
	Minimum	Maximum
N	16	
A	--	1.20
A1	0.05	0.15
A2	0.80	1.05
b	0.19	0.30
c	0.09	0.20
D	4.90	5.10
E	6.40 BASIC	
E1	4.30	4.50
e	0.65 BASIC	
L	0.45	0.75
α	0°	8°
aaa	--	0.10

Reference Document: JEDEC Publication 95, MO-153



PACKAGE OUTLINE - K SUFFIX FOR 20 LEAD VFQFN

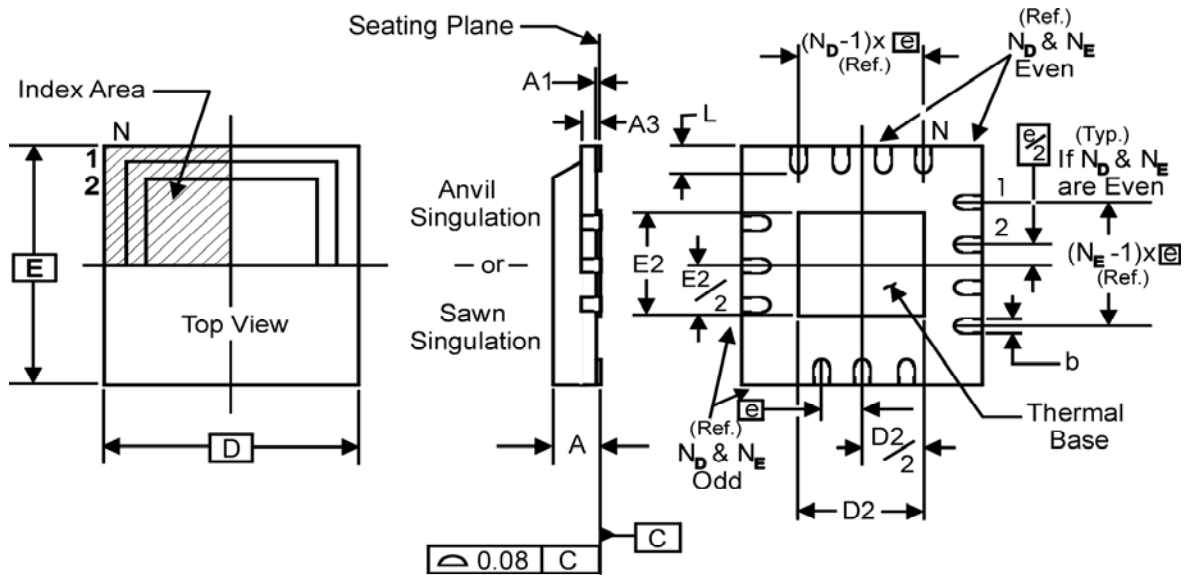

TABLE 8C. PACKAGE DIMENSIONS FOR 20 LEAD VFQFN

JEDEC VARIATION ALL DIMENSIONS IN MILLIMETERS		
SYMBOL	MINIMUM	MAXIMUM
N	20	
A	0.80	1.0
A1	0	0.05
A3	0.25 Reference	
b	0.18	0.30
e	0.50 BASIC	
N_D	5	
N_E	5	
D	4.0	
D2	0.75	2.80
E	4.0	
E2	0.75	2.80
L	0.35	0.75

Reference Document: JEDEC Publication 95, MO-220



TABLE 9. ORDERING INFORMATION

Part/Order Number	Marking	Package	Shipping Packaging	Temperature
ICS83905AM	83905AM	16 Lead SOIC	tube	0°C to 70°C
ICS83905AMT	83905AM	16 Lead SOIC	2500 tape & reel	0°C to 70°C
ICS83905AMLF	83905AML	16 Lead "Lead-Free" SOIC	tube	0°C to 70°C
ICS83905AMLFT	83905AML	16 Lead "Lead-Free" SOIC	2500 tape & reel	0°C to 70°C
ICS83905AGLF	83905AGL	16 Lead "Lead-Free" TSSOP	tube	0°C to 70°C
ICS83905AGLFT	83905AGL	16 Lead "Lead-Free" TSSOP	2500 tape & reel	0°C to 70°C
ICS83905AK	83905A	20 Lead VFQFN	tube	0°C to 70°C
ICS83905AKT	83905A	20 Lead VFQFN	2500 tape & reel	0°C to 70°C

NOTE: Parts that are ordered with an "LF" suffix to the part number are the Pb-Free configuration and are RoHS compliant.

The aforementioned trademark, HiPerClockS™ is a trademark of Integrated Circuit Systems, Inc. or its subsidiaries in the United States and/or other countries. While the information presented herein has been checked for both accuracy and reliability, Integrated Circuit Systems, Incorporated (ICS) assumes no responsibility for either its use or for infringement of any patents or other rights of third parties, which would result from its use. No other circuits, patents, or licenses are implied. This product is intended for use in normal commercial and industrial applications. Any other applications such as those requiring high reliability or other extraordinary environmental requirements are not recommended without additional processing by ICS. ICS reserves the right to change any circuitry or specifications without notice. ICS does not authorize or warrant any ICS product for use in life support devices or critical medical instruments.