



Chipsmall Limited consists of a professional team with an average of over 10 year of expertise in the distribution of electronic components. Based in Hongkong, we have already established firm and mutual-benefit business relationships with customers from,Europe,America and south Asia,supplying obsolete and hard-to-find components to meet their specific needs.

With the principle of “Quality Parts,Customers Priority,Honest Operation,and Considerate Service”,our business mainly focus on the distribution of electronic components. Line cards we deal with include Microchip,ALPS,ROHM,Xilinx,Pulse,ON,Everlight and Freescale. Main products comprise IC,Modules,Potentiometer,IC Socket,Relay,Connector.Our parts cover such applications as commercial,industrial, and automotives areas.

We are looking forward to setting up business relationship with you and hope to provide you with the best service and solution. Let us make a better world for our industry!



## Contact us

Tel: +86-755-8981 8866 Fax: +86-755-8427 6832

Email & Skype: info@chipsmall.com Web: www.chipsmall.com

Address: A1208, Overseas Decoration Building, #122 Zhenhua RD., Futian, Shenzhen, China





# QUAD, 1-TO-1, DIFFERENTIAL-TO-2.5V, 3.3V, 5V LVPECL RECEIVER

# ICS853017

## GENERAL DESCRIPTION



The ICS853017 is a quad 1-to-1, 2.5V/3.3V/5V differential LVPECL/ECL receiver and a member of the HiperClocks™ family of High Performance Clock Solutions from IDT. The ICS853017 operates with a positive or negative power supply at 2.5V, 3.3V or 5V, and can accept both single-ended and differential inputs. For single-ended operation, an internally generated voltage, which is available on output pin  $V_{BB}$ , can be used as a switching bias voltage on the unused input of the differential pair.  $V_{BB}$  can also be used to rebias AC coupled inputs.

## FEATURES

- Four differential LVPECL / ECL 1:1 receivers
- Four differential LVPECL clock input pairs
- Dx, nDx pairs can accept the following differential input levels: LVPECL, LVDS, CML, SSTL
- Output frequency: >2GHz (typical)
- Translates any single ended input signal to LVPECL levels with resistor bias on nDx input
- Output skew: TBD
- Part-to-part skew: TBD
- Propagation delay: 320ps (typical)
- LVPECL mode operating voltage supply range:  $V_{CC} = 2.375V$  to  $5.25V$
- ECL mode operating voltage supply range:  $V_{CC} = 0V$ ,  $V_{EE} = -5.25V$  to  $-2.375V$
- $-40^{\circ}C$  to  $85^{\circ}C$  ambient operating temperature
- Available in both standard (RoHS 5) and lead-free (RoHS 6) packages

## BLOCK DIAGRAM

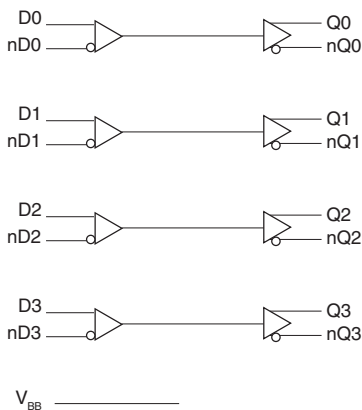

## PIN ASSIGNMENT

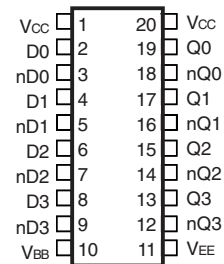

**ICS853017**  
**20-Lead, 300-MIL SOIC**  
 7.5mm x 12.8mm x 2.3mm body package  
**M Package**  
 Top View

The Preliminary Information presented herein represents a product in pre-production. The noted characteristics are based on initial product characterization and/or qualification. Integrated Device Technology, Incorporated (IDT) reserves the right to change any circuitry or specifications without notice.

**TABLE 1. PIN DESCRIPTIONS**

Number	Name	Type		Description
1, 20	V <sub>CC</sub>	Power		Positive supply pins.
2	D0	Input	Pulldown	Non-inverting differential clock input.
3	nD0	Input	Pullup/ Pulldown	Inverting differential clock input. V <sub>CC</sub> /2 default when left floating.
4	D1	Input	Pulldown	Non-inverting differential clock input.
5	nD1	Input	Pullup/ Pulldown	Inverting differential clock input. V <sub>CC</sub> /2 default when left floating.
6	D2	Input	Pulldown	Non-inverting differential clock input.
7	nD2	Input	Pullup/ Pulldown	Inverting differential clock input. V <sub>CC</sub> /2 default when left floating.
8	D3	Input	Pulldown	Non-inverting differential clock input.
9	nD3	Input	Pullup/ Pulldown	Inverting differential clock input. V <sub>CC</sub> /2 default when left floating.
10	V <sub>BB</sub>	Power		Bias Voltage.
11	V <sub>EE</sub>	Power		Negative supply pin.
12, 13	nQ3, Q3	Output		Differential output pair. LVPECL interface levels.
14, 15	nQ2, Q2	Output		Differential output pair. LVPECL interface levels.
17, 18	nQ1, Q1	Output		Differential output pair. LVPECL interface levels.
19, 20	nQ0, Q0	Output		Differential output pair. LVPECL interface levels.

NOTE: *Pullup* and *Pulldown* refer to internal input resistors. See Table 2, Pin Characteristics, for typical values.

**TABLE 2. PIN CHARACTERISTICS**

Symbol	Parameter	Test Conditions	Minimum	Typical	Maximum	Units
R <sub>PULLDOWN</sub>	Input Pulldown Resistor			75		kΩ
R <sub>VCC/2</sub>	Pullup/Pulldown Resistors			50		kΩ

**TABLE 3. CLOCK INPUT FUNCTION TABLE**

Inputs		Outputs		Input to Output Mode	Polarity
D0:D3	nD0:nD3	Q0:Q3	nQ0:nQ3,		
0	1	LOW	HIGH	Differential to Differential	Non Inverting
1	0	HIGH	LOW	Differential to Differential	Non Inverting
0	Biased; NOTE 1	LOW	HIGH	Single Ended to Differential	Non Inverting
1	Biased; NOTE 1	HIGH	LOW	Single Ended to Differential	Non Inverting
Biased; NOTE 1	0	HIGH	LOW	Single Ended to Differential	Inverting
Biased; NOTE 1	1	LOW	HIGH	Single Ended to Differential	Inverting

NOTE 1: Please refer to the Application Information, "Wiring the Differential Input to Accept Single Ended Levels".



## ABSOLUTE MAXIMUM RATINGS

Supply Voltage, $V_{CC}$	5.5V (LVPECL mode, $V_{EE} = 0$ )
Negative Supply Voltage, $V_{EE}$	-5.5V (ECL mode, $V_{CC} = 0$ )
Inputs, $V_I$ (LVPECL mode)	-0.5V to $V_{CC} + 0.5V$
Inputs, $V_I$ (ECL mode)	0.5V to $V_{EE} - 0.5V$
Outputs, $I_O$	
Continuous Current	50mA
Surge Current	100mA
$V_{BB}$ Sing/Source, $I_{BB}$	$\pm 0.5mA$
Operating Temperature Range, $T_A$	-40°C to +85°C
Storage Temperature, $T_{STG}$	-65°C to 150°C
Package Thermal Impedance, $\theta_{JA}$ (Junction-to-Ambient)	46.2°C/W (0 lfpm)

**NOTE:** Stresses beyond those listed under Absolute Maximum Ratings may cause permanent damage to the device. These ratings are stress specifications only. Functional operation of product at these conditions or any conditions beyond those listed in the *DC Characteristics* or *AC Characteristics* is not implied. Exposure to absolute maximum rating conditions for extended periods may affect product reliability.

**TABLE 4A. POWER SUPPLY DC CHARACTERISTICS,  $V_{CC} = 2.375V$  TO  $5.25V$ ;  $V_{EE} = 0V$**

Symbol	Parameter	Test Conditions	Minimum	Typical	Maximum	Units
$V_{CC}$	Core Supply Voltage		2.375	3.3	5.25	V
$I_{EE}$	Power Supply Current			46		mA

**TABLE 4B. LVPECL DC CHARACTERISTICS,  $V_{CC} = 3.3V$ ;  $V_{EE} = 0V$**

Symbol	Parameter	-40°C			25°C			85°C			Units
		Min	Typ	Max	Min	Typ	Max	Min	Typ	Max	
$V_{OH}$	Output High Voltage; NOTE 1		2.275			2.295			2.33		V
$V_{OL}$	Output Low Voltage; NOTE 1		1.545			1.52			1.535		V
$V_{IH}$	Input High Voltage, Single-Ended	2.075			2.075			2.075			V
$V_{IL}$	Input Low Voltage, Single-Ended	1.43			1.43			1.43			V
$V_{BB}$	Output Voltage Reference; NOTE 2	1.86			1.86			1.86			V
$V_{PP}$	Peak-to-Peak Input Voltage		800			800			800		mV
$V_{CMR}$	Input High Voltage Common Mode Range; NOTE 3, 4	1.2		3.3	1.2		3.3	1.2		3.3	V
$I_{IH}$	Input High Current	D0, D1, D2, D3 nD0, nD1, nD2, nD3		200			200			200	$\mu A$
$I_{IL}$	Input Low Current	D0, D1, D2, D3 nD0, nD1, nD2, nD3	-10			-10			-10		$\mu A$
			-150			-150			-150		$\mu A$

Input and output parameters vary 1:1 with  $V_{CC}$ .  $V_{EE}$  can vary +0.925V to -0.5V.

NOTE 1: Outputs terminated with 50 $\Omega$  to  $V_{CC} - 2V$ .

NOTE 2: Single-ended input operation is limited.  $V_{CC} \geq 3V$  in LVPECL mode.

NOTE 3: Common mode voltage is defined as  $V_{IH}$ .

NOTE 4: For single-ended applications, the maximum input voltage for Dx, nDx is  $V_{CC} + 0.3V$ .

**TABLE 4C. LVPECL DC CHARACTERISTICS,  $V_{CC} = 2.5V$ ;  $V_{EE} = 0V$** 

Symbol	Parameter	-40°C			25°C			85°C			Units
		Min	Typ	Max	Min	Typ	Max	Min	Typ	Max	
$V_{OH}$	Output High Voltage; NOTE 1		1.475			1.495			1.53		V
$V_{OL}$	Output Low Voltage; NOTE 1		0.745			0.72			0.735		V
$V_{IH}$	Input High Voltage, Single-Ended	1.275			1.275			1.275			V
$V_{IL}$	Input Low Voltage, Single-Ended	0.63			0.63			0.63			V
$V_{PP}$	Peak-to-Peak Input Voltage		800			800			800		mV
$V_{CMR}$	Input High Voltage Common Mode Range; NOTE 2, 3	1.2		2.5	1.2		2.5	1.2		2.5	V
$I_{IH}$	Input High Current	D0, D1, D2, D3 nD0, nD1, nD2, nD3		200			200			200	$\mu A$
$I_{IL}$	Input Low Current	D0, D1, D2, D3		-10			-10			-10	$\mu A$
		nD0, nD1, nD2, nD3		-150			-150			-150	$\mu A$

Input and output parameters vary 1:1 with  $V_{CC}$ .  $V_{EE}$  can vary +0.925V to -0.5V.

NOTE 1: Outputs terminated with 50 $\Omega$  to  $V_{CC} - 2V$ .

NOTE 2: Common mode voltage is defined as  $V_{IH}$ .

NOTE 3: For single-ended applications, the maximum input voltage for Dx, nDx is  $V_{CC} + 0.3V$ .

**TABLE 4D. LVPECL DC CHARACTERISTICS,  $V_{CC} = 5V$ ;  $V_{EE} = 0V$** 

Symbol	Parameter	-40°C			25°C			85°C			Units
		Min	Typ	Max	Min	Typ	Max	Min	Typ	Max	
$V_{OH}$	Output High Voltage; NOTE 1		3.975			3.995			4.03		V
$V_{OL}$	Output Low Voltage; NOTE 1		3.245			3.22			3.235		V
$V_{IH}$	Input High Voltage, Single-Ended	3.775			3.775			3.775			V
$V_{IL}$	Input Low Voltage, Single-Ended	3.13			3.13			3.13			V
$V_{PP}$	Peak-to-Peak Input Voltage		800			800			800		mV
$V_{CMR}$	Input High Voltage Common Mode Range; NOTE 2, 3	1.2		5	1.2		5	1.2		5	V
$I_{IH}$	Input High Current	D0, D1, D2, D3 nD0, nD1, nD2, nD3		200			200			200	$\mu A$
$I_{IL}$	Input Low Current	D0, D1, D2, D3		-10			-10			-10	$\mu A$
		nD0, nD1, nD2, nD3		-200			-200			-200	$\mu A$

Input and output parameters vary 1:1 with  $V_{CC}$ .  $V_{EE}$  can vary +0.925V to -0.5V.

NOTE 1: Outputs terminated with 50 $\Omega$  to  $V_{CC} - 2V$ .

NOTE 2: Common mode voltage is defined as  $V_{IH}$ .

NOTE 3: For single-ended applications, the maximum input voltage for Dx, nDx is  $V_{CC} + 0.3V$ .

**TABLE 4C. ECL DC CHARACTERISTICS,  $V_{CC} = 0V$ ;  $V_{EE} = -5.25V$  TO  $-2.375V$** 

Symbol	Parameter	-40°C			25°C			85°C			Units
		Min	Typ	Max	Min	Typ	Max	Min	Typ	Max	
$V_{OH}$	Output High Voltage; NOTE 1		-1.025			-1.005			-0.97		V
$V_{OL}$	Output Low Voltage; NOTE 1		-1.755			-1.78			-1.765		V
$V_{IH}$	Input High Voltage, Single-Ended	-1.225			-1.225			-1.225			V
$V_{IL}$	Input Low Voltage, Single-Ended	-1.87			-1.87			-1.87			V
$V_{BB}$	Output Voltage Reference; NOTE 2	-1.44			-1.44			-1.44			V
$V_{PP}$	Peak-to-Peak Input Voltage		800			800			800		mV
$V_{CMR}$	Input High Voltage Common Mode Range; NOTE 3, 4	$V_{EE}+1.2V$		0	$V_{EE}+1.2V$		0	$V_{EE}+1.2V$		0	V
$I_{IH}$	Input High Current	D0:D3, nD0:nD3		200			200			200	$\mu A$
$I_{IL}$	Input Low Current	D0:D3	-10		-10			-10			$\mu A$
		nD0:nD3	-200		-200			-200			$\mu A$

Input and output parameters vary 1:1 with  $V_{CC}$ .  $V_{EE}$  can vary +0.925V to -0.5V.

NOTE 1: Outputs terminated with  $50\Omega$  to  $V_{CC} - 2V$ .

NOTE 2: Single-ended input operation is limited.  $V_{CC} \geq 3V$  in LVPECL mode.

NOTE 3: Common mode voltage is defined as  $V_{IH}$ .

NOTE 4: For single-ended applications, the maximum input voltage for Dx, nDx is  $V_{CC} + 0.3V$ .

**TABLE 5. AC CHARACTERISTICS,  $V_{CC} = 0V$ ;  $V_{EE} = -5.25V$  TO  $-2.375V$  OR  $V_{CC} = 2.375V$  TO  $5.25V$ ;  $V_{EE} = 0V$** 

Symbol	Parameter	-40°C			25°C			85°C			Units
		Min	Typ	Max	Min	Typ	Max	Min	Typ	Max	
$f_{MAX}$	Output Frequency		>2			>2			>2		GHz
$tp_{LH}$	Propagation Delay, Low-to-High; NOTE 1		320			320			320		ps
$tp_{HL}$	Propagation Delay, High-to-Low; NOTE 1		320			320			320		ps
$t_{sk}(o)$	Output Skew; NOTE 2, 4		TBD			TBD			TBD		ps
$t_{sk}(pp)$	Part-to-Part Skew; NOTE 3, 4		TBD			TBD			TBD		ps
$t_R/t_F$	Output Rise/Fall Time	20% to 80%	175		175			175			ps

All parameters tested  $\leq 1GHz$  unless otherwise noted.

NOTE 1: Measured from the differential input crossing point to the differential output crossing point.

NOTE 2: Defined as skew between outputs at the same supply voltage and with equal load conditions.

Measured at the output differential cross points.

NOTE 3: Defined as skew between outputs on different devices operating at the same supply voltages and with equal load conditions. Using the same type of inputs on each device, the outputs are measured at the differential cross points.

NOTE 4: This parameter is defined in accordance with JEDEC Standard 65.

# PARAMETER MEASUREMENT INFORMATION

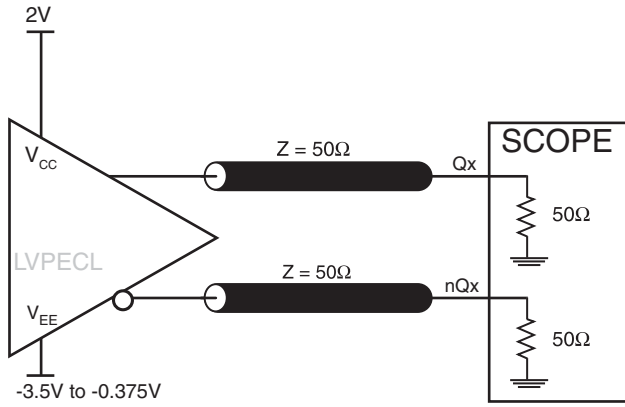

**OUTPUT LOAD AC TEST CIRCUIT**

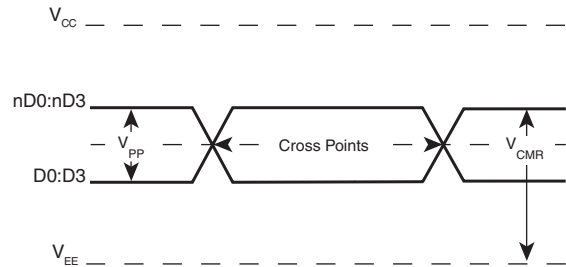

**DIFFERENTIAL INPUT LEVEL**

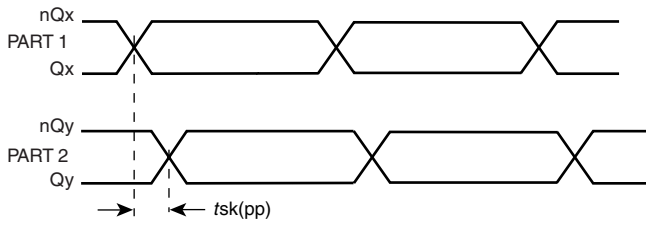

**PART-TO-PART SKEW**

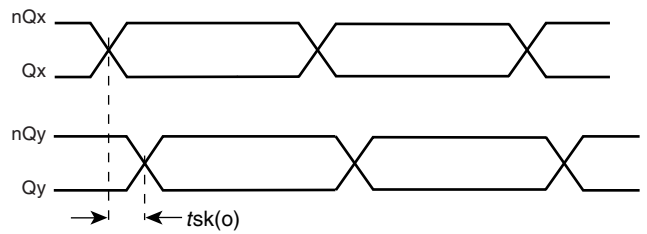

**OUTPUT SKEW**

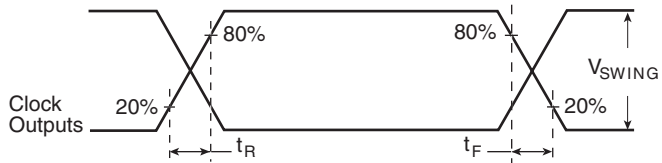

**OUTPUT RISE/FALL TIME**

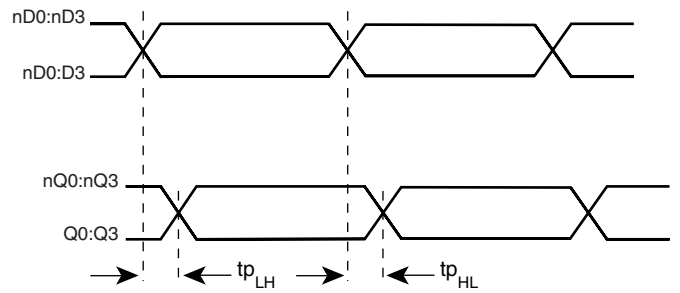

**PROPAGATION DELAY**

# APPLICATION INFORMATION

## WIRING THE DIFFERENTIAL INPUT TO ACCEPT SINGLE ENDED LEVELS

Figure 1A shows how the differential input can be wired to accept single ended levels. The reference voltage  $V_{REF} \approx V_{cc}/2$  is generated by the bias resistors R1, R2 and C1. This bias circuit should be located as close as possible to the input pin. The ratio

of R1 and R2 might need to be adjusted to position the  $V_{REF}$  in the center of the input voltage swing. For example, if the input clock swing is only 2.5V and  $V_{cc} = 3.3V$ ,  $V_{REF}$  should be 1.25V and  $R2/R1 = 0.609$ .

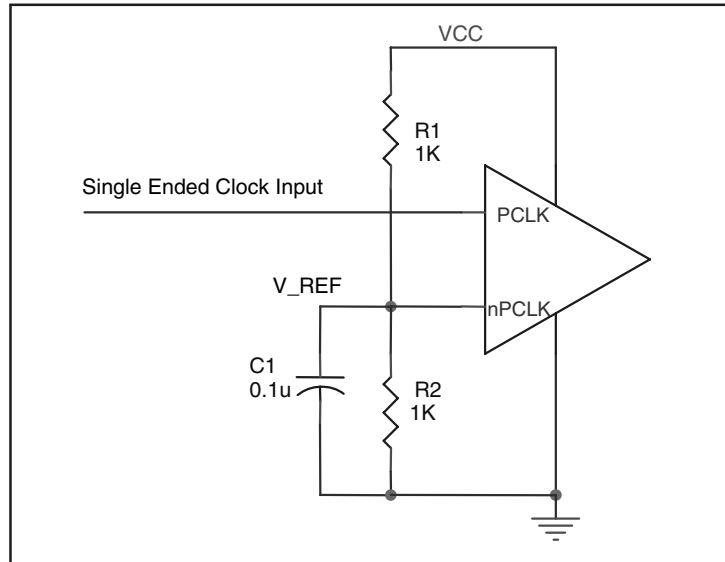

FIGURE 1A. SINGLE ENDED SIGNAL DRIVING DIFFERENTIAL INPUT

## WIRING THE DIFFERENTIAL INPUT TO ACCEPT SINGLE ENDED LVPECL LEVELS

Figure 1B shows an example of the differential input that can be wired to accept single ended LVPECL levels. The reference voltage level  $V_{BB}$  generated from the device is connected to the

negative input. The C1 capacitor should be located as close as possible to the input pin.

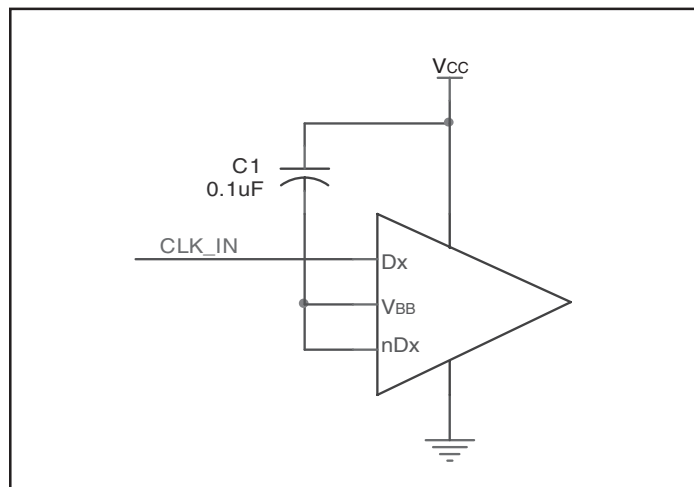

FIGURE 1B. SINGLE ENDED LVPECL SIGNAL DRIVING DIFFERENTIAL INPUT



## LVPECL CLOCK INPUT INTERFACE

The Dx/nDx accepts LVPECL, CML, SSTL and other differential signals. Both  $V_{SWING}$  and  $V_{OH}$  must meet the  $V_{PP}$  and  $V_{CMR}$  input requirements. Figures 2A to 2E show interface examples for the HiPerClockS Dx/nDx input driven by the most common driver

types. The input interfaces suggested here are examples only. If the driver is from another vendor, use their termination recommendation. Please consult with the vendor of the driver component to confirm the driver termination requirements.

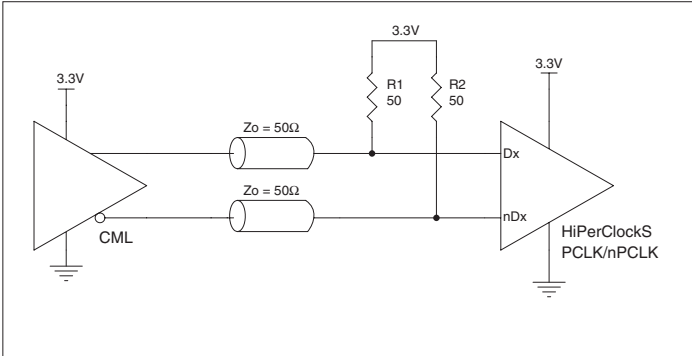

**FIGURE 2A. HiPerClockS D/nD INPUT DRIVEN BY A CML DRIVER**

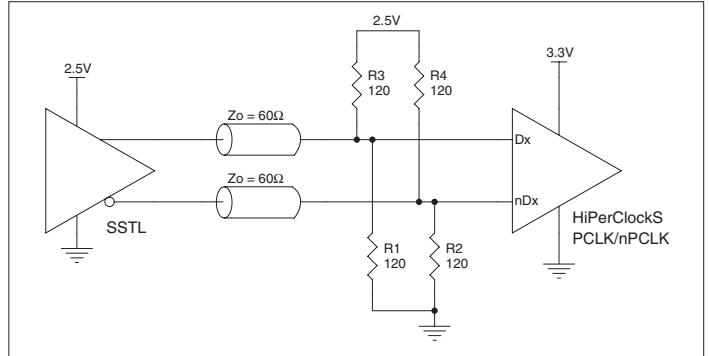

**FIGURE 2B. HiPerClockS D/nD INPUT DRIVEN BY AN SSTL DRIVER**

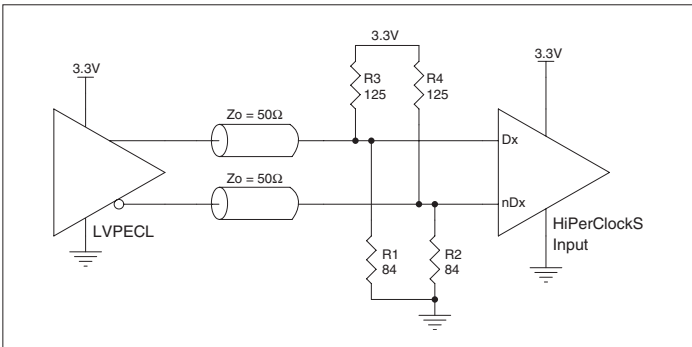

**FIGURE 2C. HiPerClockS D/nD INPUT DRIVEN BY A 3.3V LVPECL DRIVER**

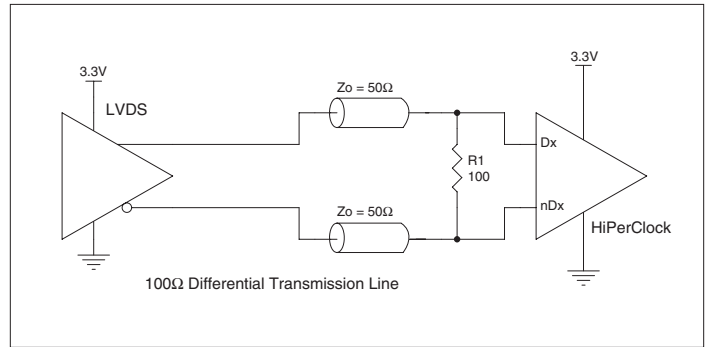

**FIGURE 2D. HiPerClockS D/nD INPUT DRIVEN BY A 3.3V LVDS DRIVER**

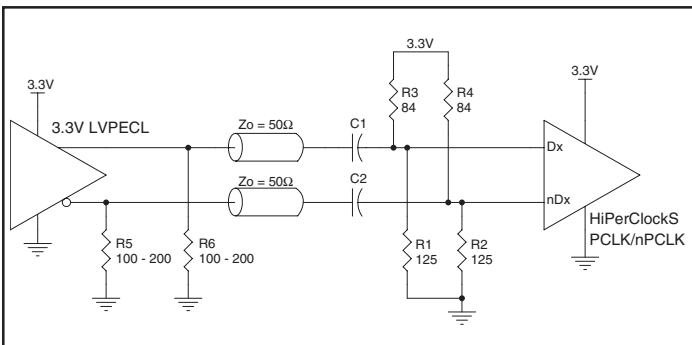

**FIGURE 2E. HiPerClockS D/nD INPUT DRIVEN BY A 3.3V LVPECL DRIVER WITH AC COUPLE**

### TERMINATION FOR 3.3V LVPECL OUTPUTS

The clock layout topology shown below is a typical termination for LVPECL outputs. The two different layouts mentioned are recommended only as guidelines.

FOUT and nFOUT are low impedance follower outputs that generate ECL/LVPECL compatible outputs. Therefore, terminating resistors (DC current path to ground) or current sources must be used for functionality. These outputs are designed to drive 50Ω

transmission lines. Matched impedance techniques should be used to maximize operating frequency and minimize signal distortion. *Figures 3A and 3B* show two different layouts which are recommended only as guidelines. Other suitable clock layouts may exist and it would be recommended that the board designers simulate to guarantee compatibility across all printed circuit and clock component process variations.

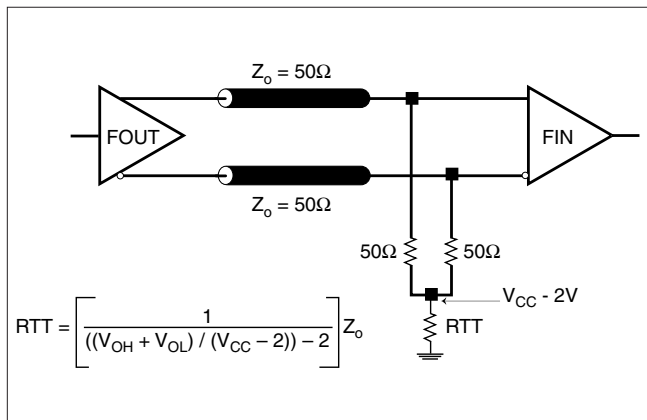

FIGURE 3A. LVPECL OUTPUT TERMINATION

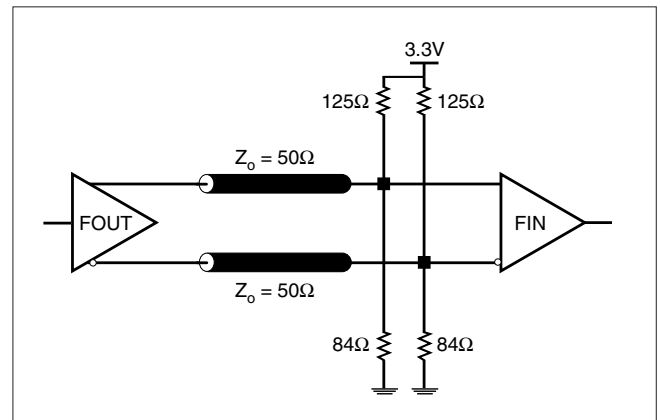

FIGURE 3B. LVPECL OUTPUT TERMINATION

### TERMINATION FOR 5V LVPECL OUTPUT

This section shows examples of 5V LVPECL output termination. *Figure 4A* shows standard termination for 5V LVPECL. The termination requires matched load of 50Ω resistors pull down to

$V_{cc} - 2V = 3V$  at the receiver. *Figure 4B* shows Thevenin equivalence of *Figure 4A*. In actual application where the 3V DC power supply is not available, this approach is normally used.

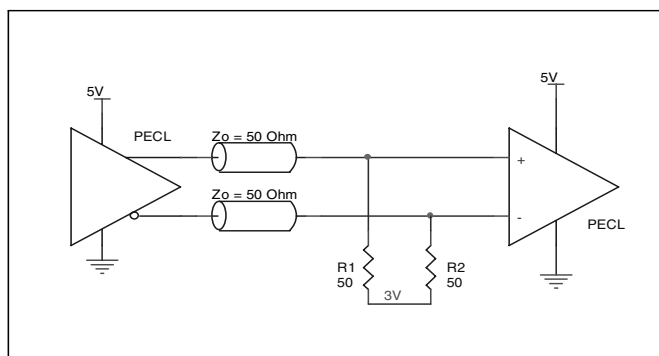

FIGURE 4A. STANDARD 5V LVPECL OUTPUT TERMINATION

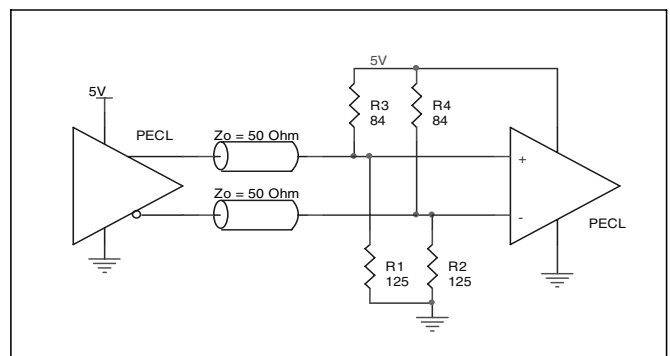

FIGURE 4B. 5V LVPECL OUTPUT TERMINATION EXAMPLE

## TERMINATION FOR 2.5V LVPECL OUTPUT

Figure 5A and Figure 5B show examples of termination for 2.5V LVPECL driver. These terminations are equivalent to terminating 50Ω to  $V_{cc} - 2V$ . For  $V_{cc} = 2.5V$ , the  $V_{cc} - 2V$  is very close to ground

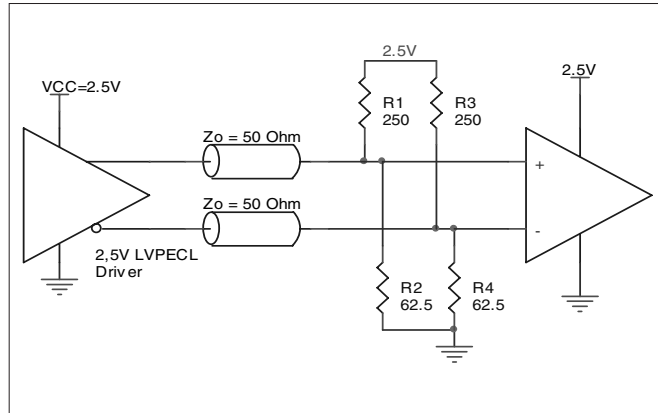

FIGURE 5A. 2.5V LVPECL DRIVER TERMINATION EXAMPLE

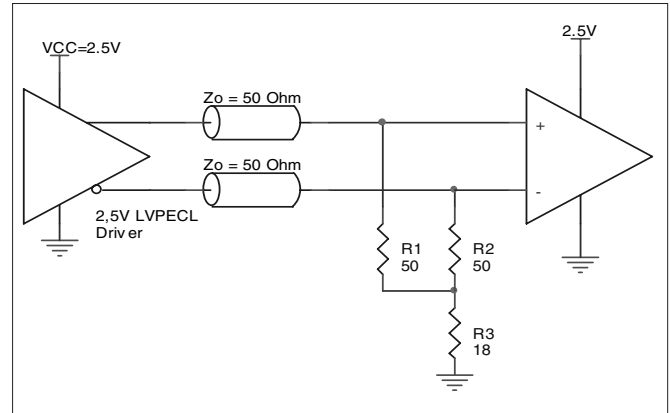

FIGURE 5B. 2.5V LVPECL DRIVER TERMINATION EXAMPLE

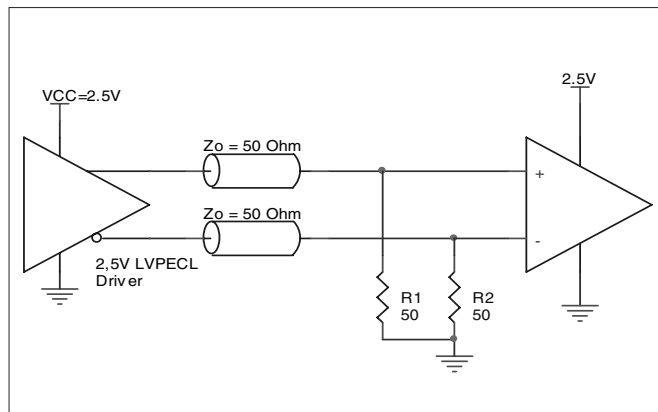

FIGURE 5C. 2.5V LVPECL TERMINATION EXAMPLE

level. The R3 in Figure 5B can be eliminated and the termination is shown in Figure 5C.

## RECOMMENDATIONS FOR UNUSED INPUT PINS

### INPUTS:

#### Dx INPUTS

For applications not requiring the use of a clock input, it can be left floating. Though not required, but for additional protection, a 1kΩ resistor can be tied from the Dx input to ground.

### OUTPUTS:

#### LVPECL OUTPUTS

All unused LVPECL outputs can be left floating. We recommend that there is no trace attached. Both sides of the differential output pair should either be left floating or terminated.

# POWER CONSIDERATIONS

This section provides information on power dissipation and junction temperature for the ICS853017. Equations and example calculations are also provided.

## 1. Power Dissipation.

The total power dissipation for the ICS853017 is the sum of the core power plus the power dissipated in the load(s). The following is the power dissipation for  $V_{CC} = 5.5V$ , which gives worst case results.

**NOTE:** Please refer to Section 3 for details on calculating power dissipated in the load.

- Power (core)<sub>MAX</sub> =  $V_{CC,MAX} * I_{EE,MAX} = 5.5V * 46mA = 253mW$
- Power (outputs)<sub>MAX</sub> = **30.94mW/Loaded Output pair**  
If all outputs are loaded, the total power is  $4 * 30.94mW = 123.76mW$

**Total Power**<sub>MAX</sub> (5.5V, with all outputs switching) =  $123.76mW + 253mW = 376.76mW$

## 2. Junction Temperature.

Junction temperature,  $T_j$ , is the temperature at the junction of the bond wire and bond pad and directly affects the reliability of the device. The maximum recommended junction temperature for HiPerClockS™ devices is 125°C.

The equation for  $T_j$  is as follows:  $T_j = \theta_{JA} * Pd_{total} + T_A$

$T_j$  = Junction Temperature

$\theta_{JA}$  = Junction-to-Ambient Thermal Resistance

$Pd_{total}$  = Total Device Power Dissipation (example calculation is in section 1 above)

$T_A$  = Ambient Temperature

In order to calculate junction temperature, the appropriate junction-to-ambient thermal resistance  $\theta_{JA}$  must be used. Assuming no air flow and a multi-layer board, the appropriate value is 46.2°C/W per Table 6 below.

Therefore,  $T_j$  for an ambient temperature of 85°C with all outputs switching is:

$85°C + 0.377W * 46.2°C/W = 102.4°C$ . This is well below the limit of 125°C.

This calculation is only an example.  $T_j$  will obviously vary depending on the number of loaded outputs, supply voltage, air flow, and the type of board (single layer or multi-layer).

**TABLE 6. THERMAL RESISTANCE  $\theta_{JA}$  FOR 20-PIN SOIC, FORCED CONVECTION**

	$\theta_{JA}$ by Velocity (Linear Feet per Minute)		
	0	200	500
Single-Layer PCB, JEDEC Standard Test Boards	83.2°C/W	65.7°C/W	57.5°C/W
Multi-Layer PCB, JEDEC Standard Test Boards	46.2°C/W	39.7°C/W	36.8°C/W

**NOTE:** Most modern PCB designs use multi-layered boards. The data in the second row pertains to most designs.

### 3. Calculations and Equations.

LVPECL output driver circuit and termination are shown in Figure 6.

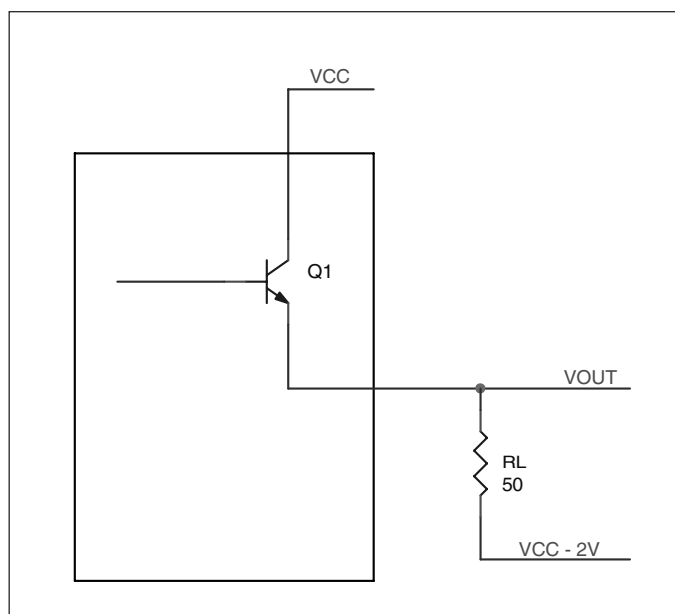

**FIGURE 6. LVPECL Driver Circuit and Termination**

To calculate worst case power dissipation into the load, use the following equations which assume a 50Ω load, and a termination voltage of  $V_{CC} - 2V$ .

- For logic high,  $V_{OUT} = V_{OH\_MAX} = V_{CC\_MAX} - 0.935V$

$$(V_{CC\_MAX} - V_{OH\_MAX}) = 0.935V$$

- For logic low,  $V_{OUT} = V_{OL\_MAX} = V_{CC\_MAX} - 1.67V$

$$(V_{CC\_MAX} - V_{OL\_MAX}) = 1.67V$$

$$Pd\_H = [(V_{OH\_MAX} - (V_{CC\_MAX} - 2V))/R_L] * (V_{CC\_MAX} - V_{OH\_MAX}) = [(2V - (V_{CC\_MAX} - V_{OH\_MAX}))/R_L] * (V_{CC\_MAX} - V_{OH\_MAX}) = [(2V - 0.935V)/50\Omega] * 0.935V = 19.92mW$$

$$Pd\_L = [(V_{OL\_MAX} - (V_{CC\_MAX} - 2V))/R_L] * (V_{CC\_MAX} - V_{OL\_MAX}) = [(2V - (V_{CC\_MAX} - V_{OL\_MAX}))/R_L] * (V_{CC\_MAX} - V_{OL\_MAX}) = [(2V - 1.67V)/50\Omega] * 1.67V = 11.02mW$$

$$\text{Total Power Dissipation per output pair} = Pd\_H + Pd\_L = 30.94mW$$



# RELIABILITY INFORMATION

TABLE 7.  $\theta_{JA}$  vs. AIR FLOW TABLE FOR 20 LEAD SOIC

	$\theta_{JA}$ by Velocity (Linear Feet per Minute)		
	0	200	500
Single-Layer PCB, JEDEC Standard Test Boards	83.2°C/W	65.7°C/W	57.5°C/W
Multi-Layer PCB, JEDEC Standard Test Boards	46.2°C/W	39.7°C/W	36.8°C/W

**NOTE:** Most modern PCB designs use multi-layered boards. The data in the second row pertains to most designs.

## TRANSISTOR COUNT

The transistor count for ICS853017 is: 187

Pin compatible with MC100EP58

PACKAGE OUTLINE - M SUFFIX FOR 20 LEAD SOIC

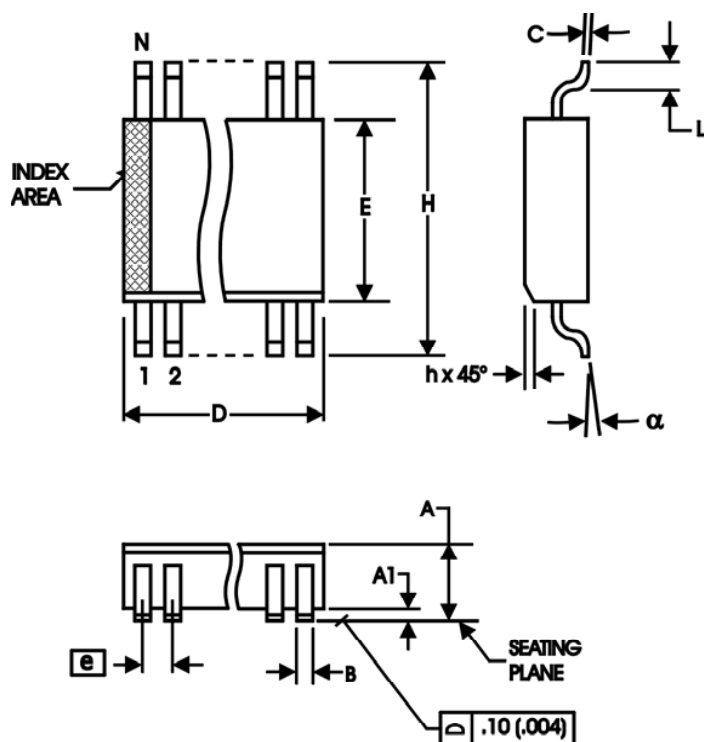

TABLE 8. PACKAGE DIMENSIONS

SYMBOL	Millimeters	
	Minimum	Maximum
N	20	
A	--	2.65
A1	0.10	--
A2	2.05	2.55
B	0.33	0.51
C	0.18	0.32
D	12.60	13.00
E	7.40	7.60
e	1.27 BASIC	
H	10.00	10.65
h	0.25	0.75
L	0.40	1.27
$\alpha$	0°	8°

Reference Document: JEDEC Publication 95, MS-013, MO-119

**TABLE 9. ORDERING INFORMATION**

<b>Part/Order Number</b>	<b>Marking</b>	<b>Package</b>	<b>Shipping Packaging</b>	<b>Temperature</b>
ICS853017AM	ICS853017AM	20 lead SOIC	tube	-40°C to 85°C
ICS853017AMT	ICS853017AM	20 lead SOIC	1000 tape & reel	-40°C to 85°C
ICS853017AMLF	TBD	20 lead "Lead-Free" SOIC	tube	-40°C to 85°C
ICS853017AMLFT	TBD	20 lead "Lead-Free" SOIC	1000 tape & reel	-40°C to 85°C

Parts that are ordered with an "LF" suffix to the part number are the Pb-Free configuration and are RoHS compliant.

While the information presented herein has been checked for both accuracy and reliability, Integrated Device Technology, Incorporated (IDT) assumes no responsibility for either its use or for infringement of any patents or other rights of third parties, which would result from its use. No other circuits, patents, or licenses are implied. This product is intended for use in normal commercial and industrial applications. Any other applications such as those requiring high reliability or other extraordinary environmental requirements are not recommended without additional processing by IDT. IDT reserves the right to change any circuitry or specifications without notice. IDT does not authorize or warrant any IDT product for use in life support devices or critical medical instruments.

**Innovate with IDT and accelerate your future networks. Contact:**

**www.IDT.com**

**For Sales**

800-345-7015  
408-284-8200  
Fax: 408-284-2775

**For Tech Support**

netcom@idt.com  
480-763-2056

---

**Corporate Headquarters**

Integrated Device Technology, Inc.  
6024 Silver Creek Valley Road  
San Jose, CA 95138  
United States  
800 345 7015  
+408 284 8200 (outside U.S.)

**Asia Pacific and Japan**

Integrated Device Technology  
Singapore (1997) Pte. Ltd.  
Reg. No. 199707558G  
435 Orchard Road  
#20-03 Wisma Atria  
Singapore 238877  
+65 6 887 5505

**Europe**

IDT Europe, Limited  
321 Kingston Road  
Leatherhead, Surrey  
KT22 7TU  
England  
+44 (0) 1372 363 339  
Fax: +44 (0) 1372 378851



www.IDT.com