



Chipsmall Limited consists of a professional team with an average of over 10 year of expertise in the distribution of electronic components. Based in Hongkong, we have already established firm and mutual-benefit business relationships with customers from,Europe,America and south Asia,supplying obsolete and hard-to-find components to meet their specific needs.

With the principle of "Quality Parts,Customers Priority,Honest Operation,and Considerate Service",our business mainly focus on the distribution of electronic components. Line cards we deal with include Microchip,ALPS,ROHM,Xilinx,Pulse,ON,Everlight and Freescale. Main products comprise IC,Modules,Potentiometer,IC Socket,Relay,Connector.Our parts cover such applications as commercial,industrial, and automotives areas.

We are looking forward to setting up business relationship with you and hope to provide you with the best service and solution. Let us make a better world for our industry!



Contact us

Tel: +86-755-8981 8866 Fax: +86-755-8427 6832

Email & Skype: info@chipsmall.com Web: www.chipsmall.com

Address: A1208, Overseas Decoration Building, #122 Zhenhua RD., Futian, Shenzhen, China





8:1, DIFFERENTIAL-TO-3.3V or 2.5V LVPECL/ECL CLOCK MULTIPLEXER

ICS853058

General Description

The ICS853058 is an 8:1 Differential-to-3.3V or 2.5V LVPECL / ECL Clock Multiplexer which can operate up to 2.8GHz and is a member of the HiPerClockS™ family of High Performance Clock Solutions from IDT. The ICS853058 has 8 differential selectable clock inputs. The PCLK, nPCLK input pairs can accept LVPECL, LVDS, CML or SSTL levels. The fully differential architecture and low propagation delay make it ideal for use in clock distribution circuits. The select pins have internal pulldown resistors. The SEL2 pin is the most significant bit and the binary number applied to the select pins will select the same numbered data input (i.e., 000 selects PCLK0, nPCLK0).



Features

- High speed 8:1 differential multiplexer
- One differential 3.3V or 2.5V LVPECL output
- Eight selectable differential PCLKx/nPCLKx input pairs
- Differential PCLKx/nPCLKx pairs can accept the following interface levels: LVPECL, LVDS, CML, SSTL
- Maximum output frequency: 2.8GHz
- Translates any single ended input signal to LVPECL levels with resistor bias on nPCLKx input
- RMS phase jitter @ 155.52MHz: 0.212ps (typical)
- Part-to-part skew: 325ps (maximum)
- Propagation delay: 450ps (maximum)
- LVPECL mode operating voltage supply range: $V_{CC} = 2.375V$ to $3.465V$, $V_{EE} = 0V$
- ECL mode operating voltage supply range: $V_{CC} = 0V$, $V_{EE} = -3.465V$ to $-2.375V$
- $-40^{\circ}C$ to $85^{\circ}C$ ambient operating temperature
- Available in both standard (RoHS 5) and lead-free (RoHS 6) packages

Block Diagram

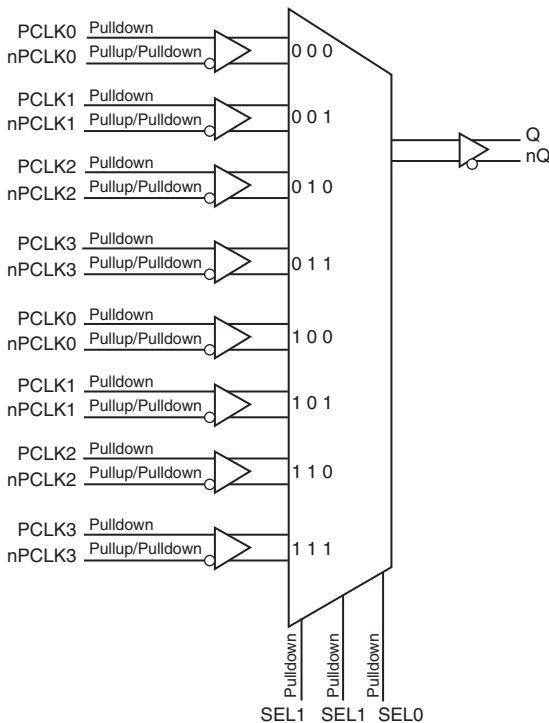

Pin Assignment

PCLK0	1	24	PCLK7
nPCLK0	2	23	nPCLK7
PCLK1	3	22	PCLK6
nPCLK1	4	21	nPCLK6
V_{CC}	5	20	V_{CC}
SEL0	6	19	Q
SEL1	7	18	nQ
SEL2	8	17	V_{EE}
PCLK2	9	16	PCLK5
nPCLK2	10	15	nPCLK5
PCLK3	11	14	PCLK4
nPCLK3	12	13	nPCLK4

ICS8530571
24-Lead TSSOP
4.4mm x 7.8mm x 0.925mm
package body
G Package
Top View

Table 1. Pin Descriptions

Number	Name	Type		Description
1	PCLK0	Input	Pulldown	Non-inverting differential clock input.
2	nPCLK0	Input	Pullup/ Pulldown	Inverting differential clock input. $V_{CC}/2$ default when left floating.
3	PCLK1	Input	Pulldown	Non-inverting differential clock input.
4	nPCLK1	Input	Pullup/ Pulldown	Inverting differential clock input. $V_{CC}/2$ default when left floating.
5, 20	V_{CC}	Power		Positive supply pins.
6, 7, 8	SEL0, SEL1, SEL2	Input	Pulldown	Clock select input pins. LVCMOS/LVTTL interface levels.
9	PCLK2	Input	Pulldown	Non-inverting differential clock input.
10	nPCLK2	Input	Pullup/ Pulldown	Inverting differential clock input. $V_{CC}/2$ default when left floating.
11	PCLK3	Input	Pulldown	Non-inverting differential clock input.
12	nPCLK3	Input	Pullup/ Pulldown	Inverting differential clock input. $V_{CC}/2$ default when left floating.
13	nPCLK4	Input	Pullup/ Pulldown	Inverting differential clock input. $V_{CC}/2$ default when left floating.
14	PCLK4	Input	Pulldown	Non-inverting differential clock input.
15	nPCLK5	Input	Pullup/ Pulldown	Inverting differential clock input. $V_{CC}/2$ default when left floating.
16	PCLK5	Input	Pulldown	Non-inverting differential clock input.
17	V_{EE}	Power		Negative supply pin.
18, 19	nQ, Q	Output		Differential output pair. LVPECL interface levels.
21	nPCLK6	Input	Pullup/ Pulldown	Inverting differential clock input. $V_{CC}/2$ default when left floating.
22	PCLK6	Input	Pulldown	Non-inverting differential clock input.
23	nPCLK7	Input	Pullup/ Pulldown	Inverting differential clock input. $V_{CC}/2$ default when left floating.
24	PCLK7	Input	Pulldown	Non-inverting differential clock input.

NOTE: Pullup and Pulldown refer to internal input resistors. See Table 2, *Pin Characteristics*, for typical values.

Table 2. Pin Characteristics

Symbol	Parameter	Test Conditions	Minimum	Typical	Maximum	Units
$R_{PULLDOWN}$	Pulldown Resistor			75		$k\Omega$
$R_{VCC/2}$	Pullup/Pulldown Resistor			50		$k\Omega$

Function Tables

Table 3. Control Input Function Table

Inputs			Outputs	
SEL2	SEL1	SEL0	Q	nQ
0	0	0	PCLK0	nPCLK0
0	0	1	PCLK1	nPCLK1
0	1	0	PCLK2	nPCLK2
0	1	1	PCLK3	nPCLK3
1	0	0	PCLK4	nPCLK4
1	0	1	PCLK5	nPCLK5
1	1	0	PCLK6	nPCLK6
1	1	1	PCLK7	nPCLK7

Absolute Maximum Ratings

NOTE: Stresses beyond those listed under *Absolute Maximum Ratings* may cause permanent damage to the device. These ratings are stress specifications only. Functional operation of product at these conditions or any conditions beyond those listed in the *DC Characteristics* or *AC Characteristics* is not implied. Exposure to absolute maximum rating conditions for extended periods may affect product reliability.

Item	Rating
Supply Voltage, V_{CC}	5.5V (LVPECL mode, $V_{EE} = 0V$)
Negative Supply Voltage, V_{EE}	-5.5V (ECL mode, $V_{CC} = 0V$)
Inputs, V_I (LVPECL mode)	-0.5V to $V_{CC} + 0.5V$
Inputs, V_I (ECL mode)	0.5V to $V_{EE} - 0.5V$
Outputs, I_O Continuos Current Surge Current	50mA 100mA
Operating Temperature Range, T_A	-40°C to +85°C
Package Thermal Impedance, θ_{JA}	70°C/W (0 mps)
Storage Temperature, T_{STG}	-65°C to 150°C

DC Electrical Characteristics

Table 4A. Power Supply DC Characteristics, $V_{CC} = 2.375V$ to $3.465V$; $V_{EE} = 0V$, $T_A = -40^\circ C$ to $85^\circ C$

Symbol	Parameter	Test Conditions	Minimum	Typical	Maximum	Units
V_{CC}	Positive Supply Voltage		2.375	3.3	3.465	V
I_{EE}	Power Supply Current				47	mA

Table 4B. LVCMOS/LVTTL DC Characteristics, $V_{CC} = 2.375V$ to $3.465V$; $V_{EE} = 0V$, $T_A = -40^{\circ}C$ to $85^{\circ}C$

Symbol	Parameter	Test Conditions	Minimum	Typical	Maximum	Units
V_{IH}	Input High Voltage		2		$V_{CC} + 0.3$	V
V_{IL}	Input Low Voltage		-0.3		0.8	V
I_{IH}	Input High Current	SEL[0:2] $V_{CC} = V_{IN} = 3.465V$ or $2.625V$			150	μA
I_{IL}	Input Low Current	SEL[0:2] $V_{CC} = 3.465V$ or $2.625V$, $V_{IN} = 0V$	-150			μA

Table 4C. LVPECL DC Characteristics, $V_{CC} = 2.375V$ to $3.465V$; $V_{EE} = 0V$, $T_A = -40^{\circ}C$ to $85^{\circ}C$

Symbol	Parameter	Test Conditions	Minimum	Typical	Maximum	Units
I_{IH}	Input High Current	PCLK[0:7], nPCLK[0:7] $V_{CC} = V_{IN} = 3.465V$ or $2.625V$			150	μA
I_{IL}	Input Low Current	PCLK[0:7] $V_{CC} = 3.465V$ or $2.625V$, $V_{IN} = 0V$	-10			μA
		nPCLK[0:7] $V_{CC} = 3.465V$ or $2.625V$, $V_{IN} = 0V$	-150			μA
V_{PP}	Peak-to-Peak Input Voltage		0.15		1.5	V
V_{CMR}	Common Mode Range; NOTE 1, 2		1.2		V_{CC}	V
V_{OH}	Output High Voltage; NOTE 3		$V_{CC} - 1.125$		$V_{CC} - 0.935$	V
V_{OL}	Output Low Voltage; NOTE 3		$V_{CC} - 1.895$		$V_{CC} - 1.670$	V
V_{SWING}	Peak-to-Peak Output Voltage Swing		0.6		1.0	V

NOTE 1: Common mode voltage is defined as V_{IH} .NOTE 2: V_{IL} should not be less than -0.3V.NOTE 3: Outputs terminated with 50Ω to $V_{CC} - 2V$ **Table 4D. ECL DC Characteristics, $V_{CC} = 0V$, $V_{EE} = -3.465V$ to $-2.375V$, $T_A = -40^{\circ}C$ to $85^{\circ}C$**

Symbol	Parameter	Test Conditions	Minimum	Typical	Maximum	Units
V_{OH}	Output High Voltage; NOTE 1		-1.225		-0.935	V
V_{OL}	Output Low Voltage; NOTE 1		-1.895		-1.67	V
V_{PP}	Peak-to-Peak Input Voltage		0.15		1.5	V
V_{CMR}	Input High Voltage Common Mode Range; NOTE 2, 3		$V_{EE} + 1.2$		0	V
I_{IH}	Input High Current	PCLK[0:7], nPCLK[0:7] $V_{CC} = V_{IN} = 3.465V$ or $2.625V$			150	μA
I_{IL}	Input Low Current	PCLK[0:7] $V_{CC} = 3.465V$ or $2.625V$, $V_{IN} = 0V$	-10			μA
		nPCLK[0:7]	-150			μA

NOTE 1: Outputs terminated with 50Ω to $V_{CC} - 2V$.NOTE 2: Common mode voltage is defined as V_{IH} .NOTE 3: V_{IL} should not be less than -0.3V

AC Electrical Characteristics

Table 5. AC Characteristics, $V_{CC} = 0V$, $V_{EE} = -3.465V$ to $-2.375V$ or $V_{CC} = 2.375$ to $3.465V$, $T_A = -40^{\circ}C$ to $85^{\circ}C$

Symbol	Parameter	Test Conditions	Minimum	Typical	Maximum	Units
f_{MAX}	Output Frequency				2.8	GHz
f_{jit}	Buffer Additive Phase Jitter, RMS; refer to Additive Phase Jitter section	155.52MHz, 12kHz – 20MHz		0.212		ps
t_{PD}	Propagation Delay; NOTE 1		125		450	ps
$t_{sk(pp)}$	Part-to-Part Skew; NOTE 2, 3				325	ps
$t_{sk(i)}$	Input Skew				75	ps
t_R / t_F	Output Rise/Fall Time	20% to 80%	75		220	ps
$MUX_{ISOLATION}$	MUX Isolation	155.52MHz, Input Peak-to-Peak = 800mV		-55		dB

All parameters measured up to 1.3GHz, unless otherwise noted.

NOTE 1: Measured from the differential input crossing point to the differential output crossing point.

NOTE 2: Defined as skew between outputs on different devices operating at the same supply voltage and with equal load conditions. Using the same type of inputs on each device, the outputs are measured at the differential cross points.

NOTE 3: This parameter is defined according with JEDEC Standard 65.

Additive Phase Jitter

The spectral purity in a band at a specific offset from the fundamental compared to the power of the fundamental is called the ***dBc Phase Noise***. This value is normally expressed using a Phase noise plot and is most often the specified plot in many applications. Phase noise is defined as the ratio of the noise power present in a 1Hz band at a specified offset from the fundamental frequency to the power value of the fundamental. This ratio is expressed in decibels (dBm) or a ratio of the power in the 1Hz band

to the power in the fundamental. When the required offset is specified, the phase noise is called a ***dBc*** value, which simply means dBm at a specified offset from the fundamental. By investigating jitter in the frequency domain, we get a better understanding of its effects on the desired application over the entire time record of the signal. It is mathematically possible to calculate an expected bit error rate given a phase noise plot.

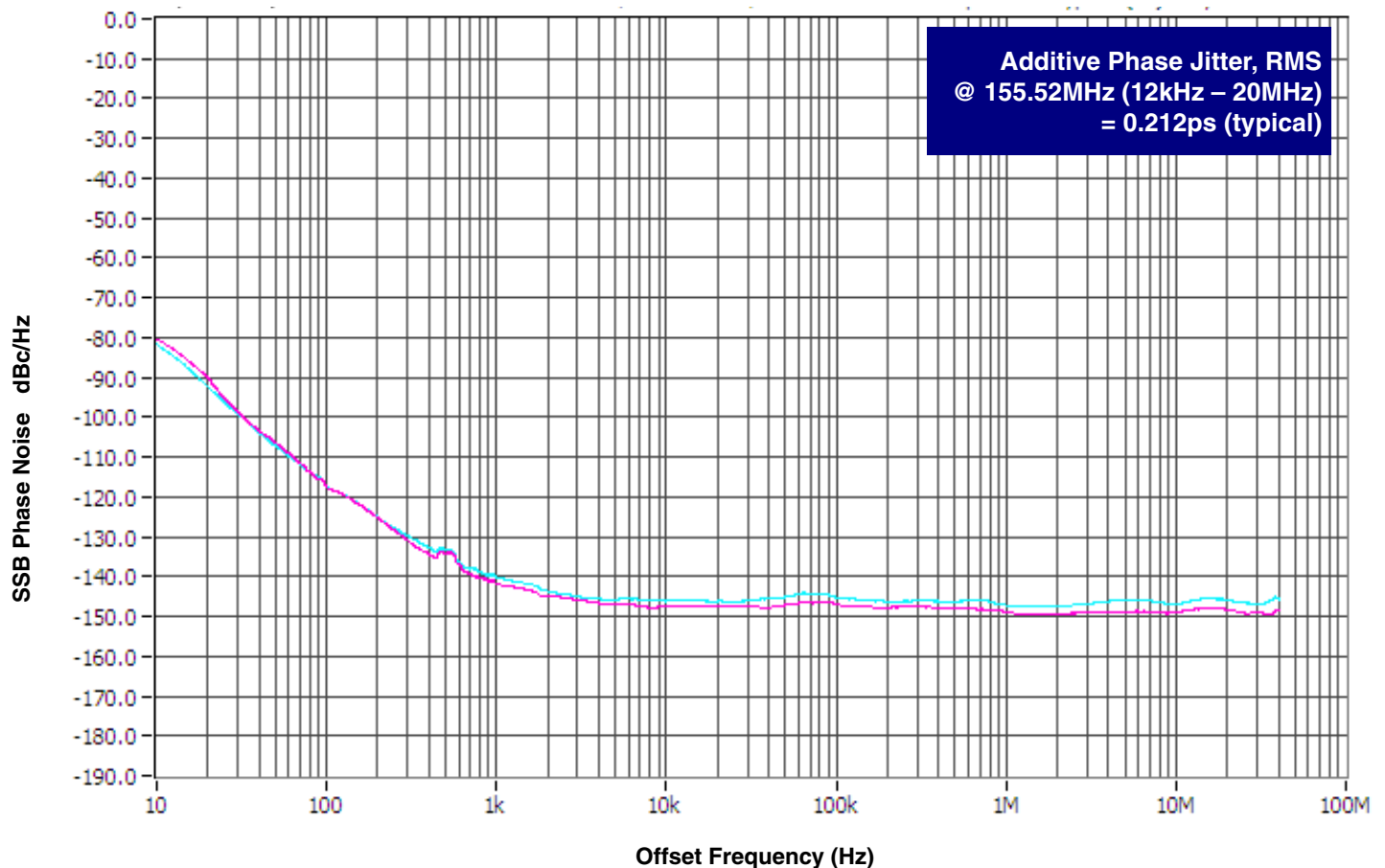

As with most timing specifications, phase noise measurements has issues relating to the limitations of the equipment. Often the noise floor of the equipment is higher than the noise floor of the

device. This is illustrated above. The device meets the noise floor of what is shown, but can actually be lower. The phase noise is dependent on the input source and measurement equipment.

Parameter Measurement Information

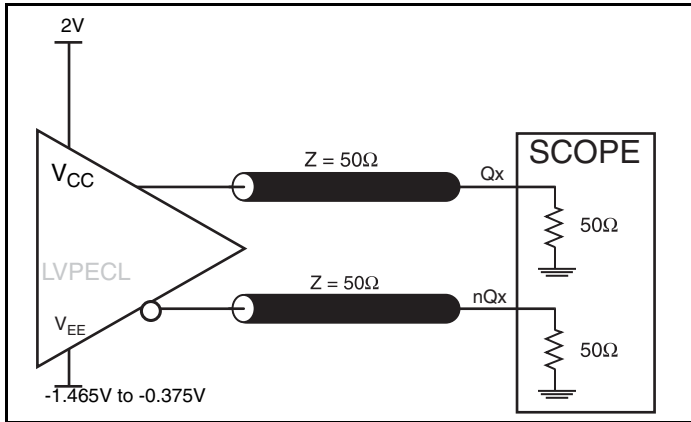

LVPECL Output Load AC Test Circuit

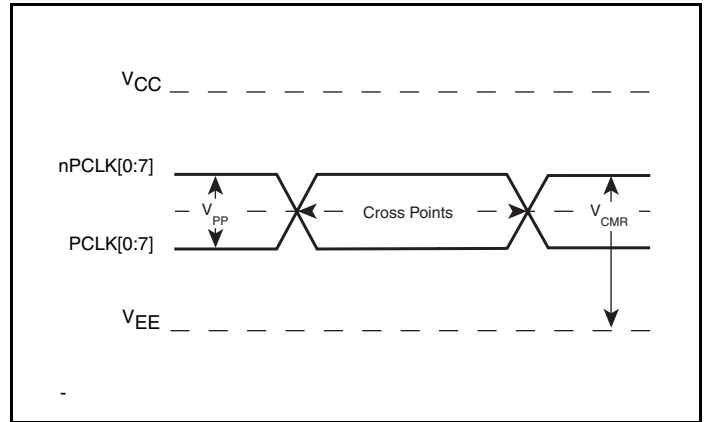

Differential Input Level

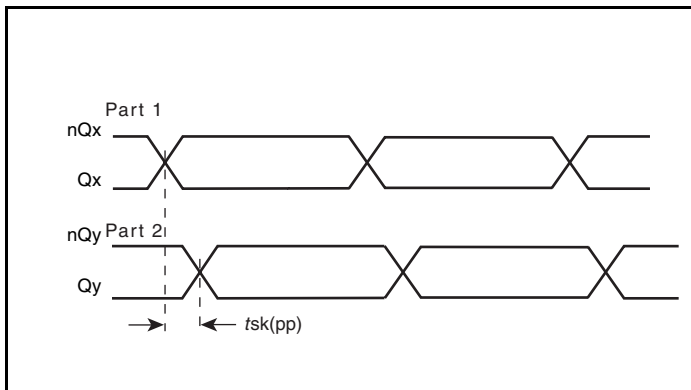

Part-to-Part Skew

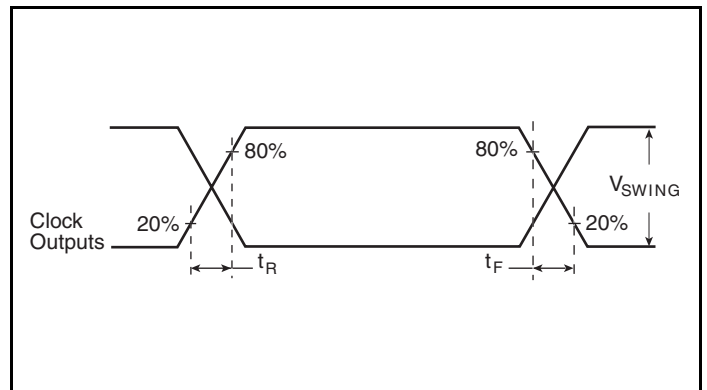

Output Rise/Fall Time

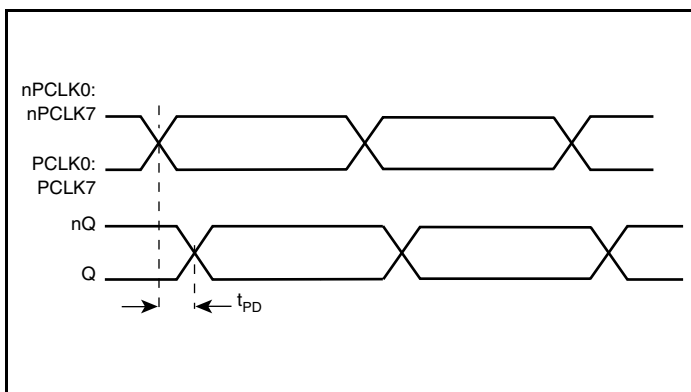

Propagation Delay

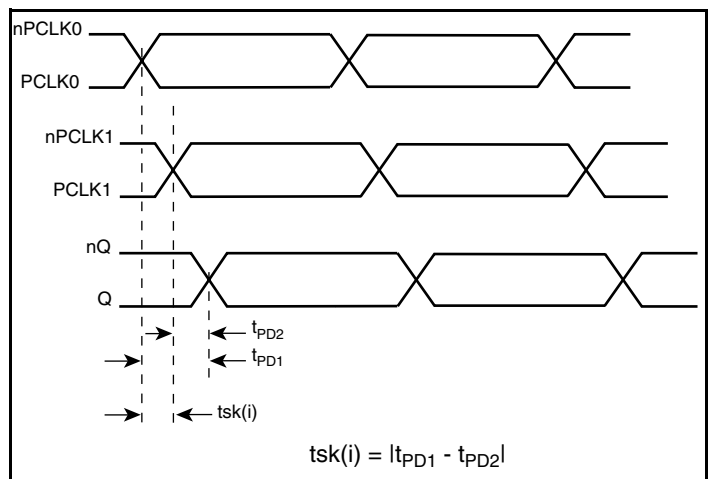

Input Skew

Parameter Measurement Information, continued

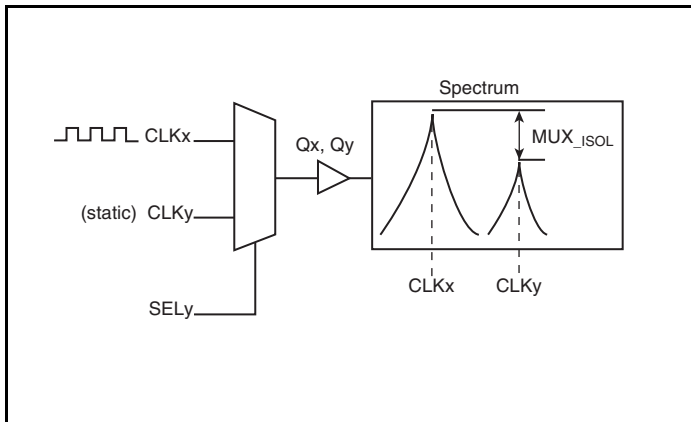

MUX Isolation

Application Information

Wiring the Differential Input to Accept Single Ended Levels

Figure 1 shows how the differential input can be wired to accept single ended levels. The reference voltage $V_REF = V_{CC}/2$ is generated by the bias resistors R1, R2 and C1. This bias circuit should be located as close as possible to the input pin. The ratio of R1 and R2 might need to be adjusted to position the V_REF in the center of the input voltage swing. For example, if the input clock swing is only 2.5V and $V_{CC} = 3.3V$, V_REF should be 1.25V and $R2/R1 = 0.609$.

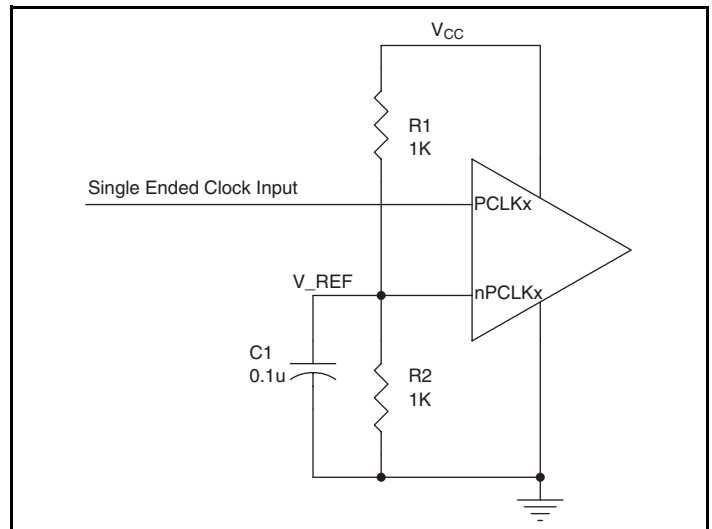

Figure 1. Single-Ended Signal Driving Differential Input

LVPECL Clock Input Interface

The PCLK /nPCLK accepts LVPECL, CML, SSTL and other differential signals. Both V_{SWING} and V_{OH} must meet the V_{PP} and V_{CMR} input requirements. Figures 2A to 2E show interface examples for the HiPerClockS PCLK/nPCLK input driven by the

most common driver types. The input interfaces suggested here are examples only. If the driver is from another vendor, use their termination recommendation. Please consult with the vendor of the driver component to confirm the driver termination requirements.

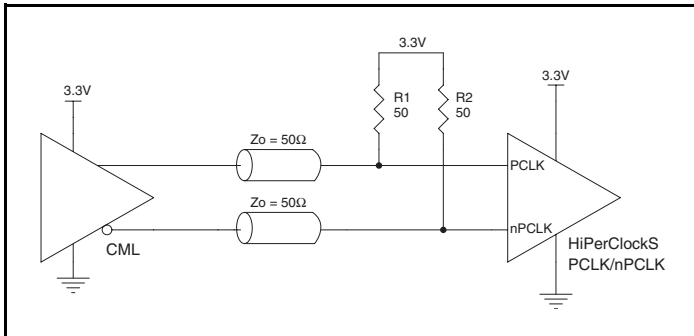

Figure 2A. HiPerClockS PCLK/nPCLK Input Driven by a CML Driver

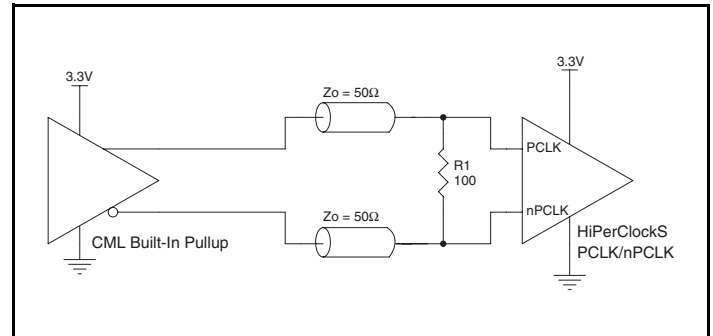

Figure 2B. HiPerClockS PCLK/nPCLK Input Driven by a Built-In Pullup CML Driver

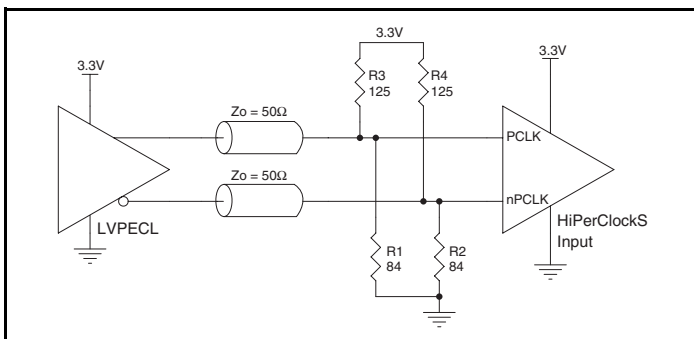

Figure 2C. HiPerClockS PCLK/nPCLK Input Driven by a 3.3V LVPECL Driver

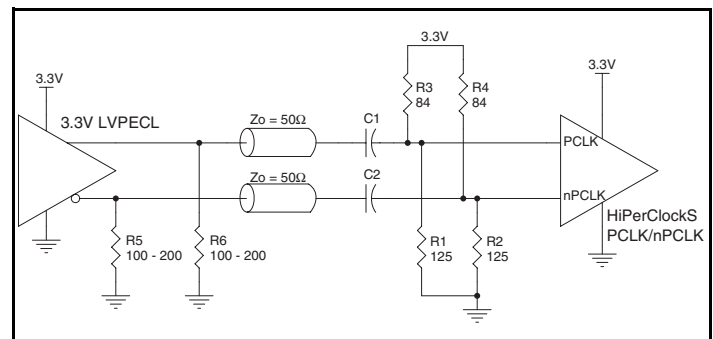

Figure 2D. HiPerClockS PCLK/nPCLK Input Driven by a 3.3V LVPECL Driver with AC Couple

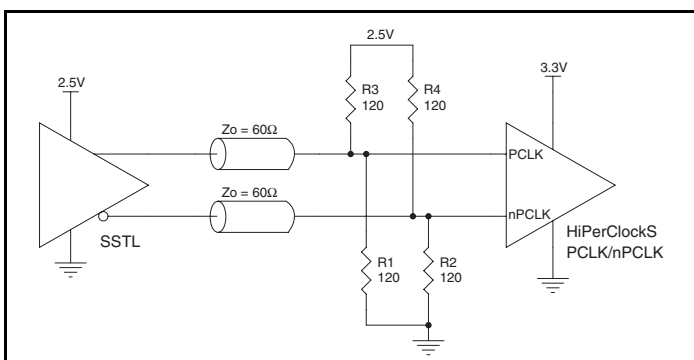

Figure 2E. HiPerClockS PCLK/nPCLK Input Driven by an SSTL Driver

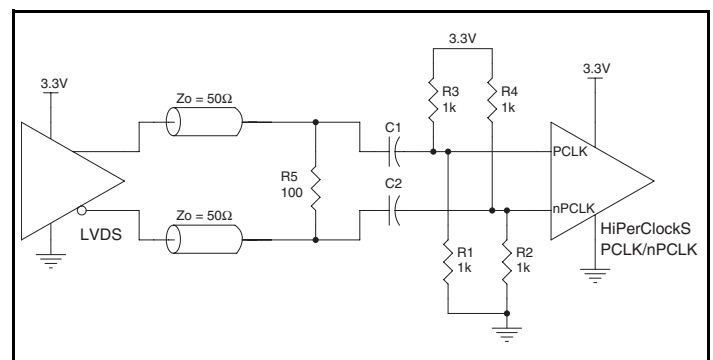

Figure 2F. HiPerClockS PCLK/nPCLK Input Driven by a 3.3V LVDS Driver

Recommendations for Unused Input Pins

Inputs:

PCLK/nPCLK INPUTS

For applications not requiring the use of the differential input, both PCLK and nPCLK can be left floating. Though not required, but for additional protection, a 1kΩ resistor can be tied from CLK to ground.

Termination for 3.3V LVPECL Outputs

The clock layout topology shown below is a typical termination for LVPECL outputs. The two different layouts mentioned are recommended only as guidelines.

FOUT and nFOUT are low impedance follower outputs that generate ECL/LVPECL compatible outputs. Therefore, terminating resistors (DC current path to ground) or current sources must be used for functionality. These outputs are designed to drive 50Ω

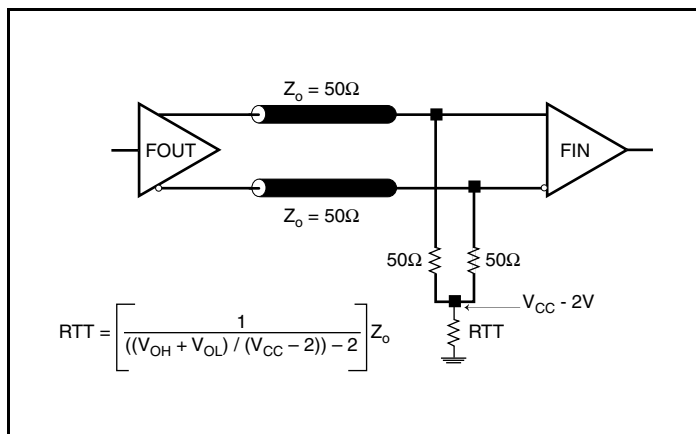

Figure 3A. 3.3V LVPECL Output Termination

LVPECL Control Pins

All control pins have internal pull-downs; additional resistance is not required but can be added for additional protection. A 1kΩ resistor can be used.

transmission lines. Matched impedance techniques should be used to maximize operating frequency and minimize signal distortion. *Figures 3A and 3B* show two different layouts which are recommended only as guidelines. Other suitable clock layouts may exist and it would be recommended that the board designers simulate to guarantee compatibility across all printed circuit and clock component process variations.

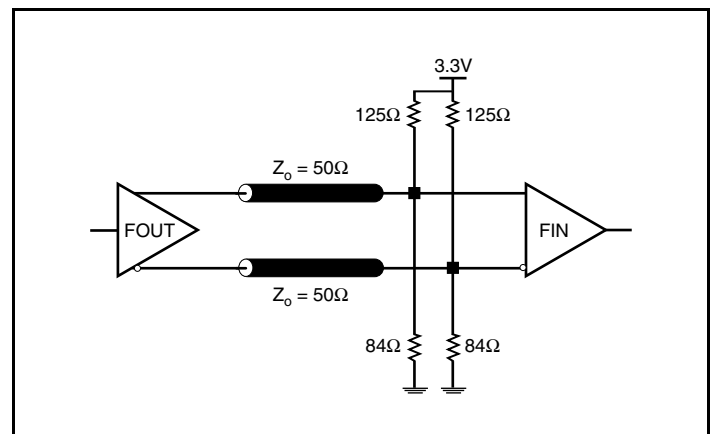

Figure 3B. 3.3V LVPECL Output Termination

Termination for 2.5V LVPECL Outputs

Figure 4A and Figure 4B show examples of termination for 2.5V LVPECL driver. These terminations are equivalent to terminating 50Ω to $V_{CC} - 2V$. For $V_{CC} = 2.5V$, the $V_{CC} - 2V$ is very close to

ground level. The R3 in Figure 4B can be eliminated and the termination is shown in Figure 4C.

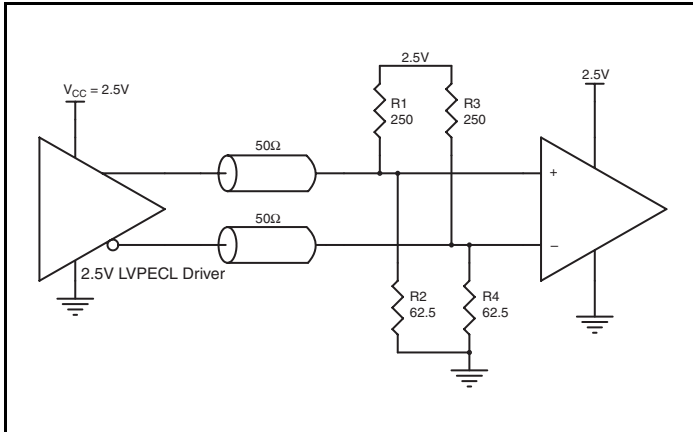

Figure 4A. 2.5V LVPECL Driver Termination Example

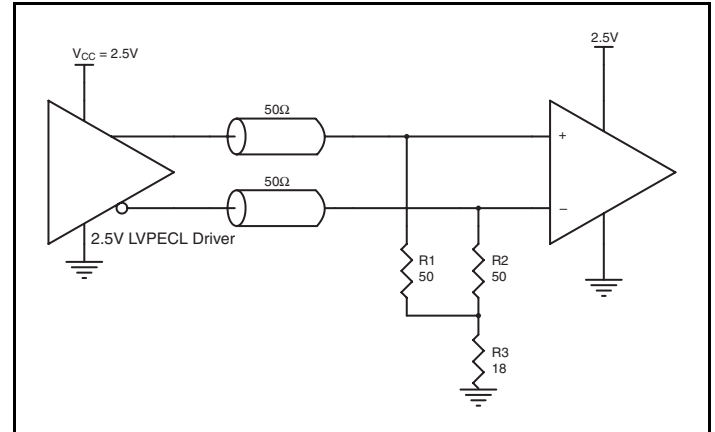

Figure 4B. 2.5V LVPECL Driver Termination Example

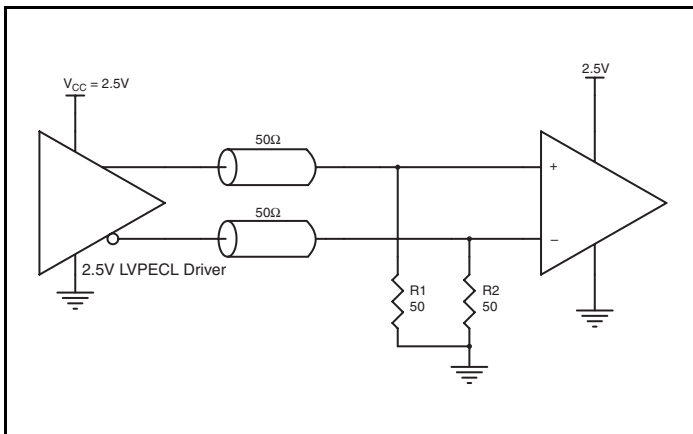

Figure 4C. 2.5V LVPECL Driver Termination Example

Schematic Example

An application schematic example of ICS853058 is shown in Figure 5. The inputs can accept various types of differential signals. In this example, the inputs are driven by LVPECL drivers. The ICS853058 output is an LVPECL driver. An example of LVPECL terminations is shown in this schematic. Other

termination approaches are available in the LVPECL Termination Application Note. It is recommended that at least one decoupling capacitor per power pin. The decoupling capacitor should be low ESR and located as close as possible to the power pin.

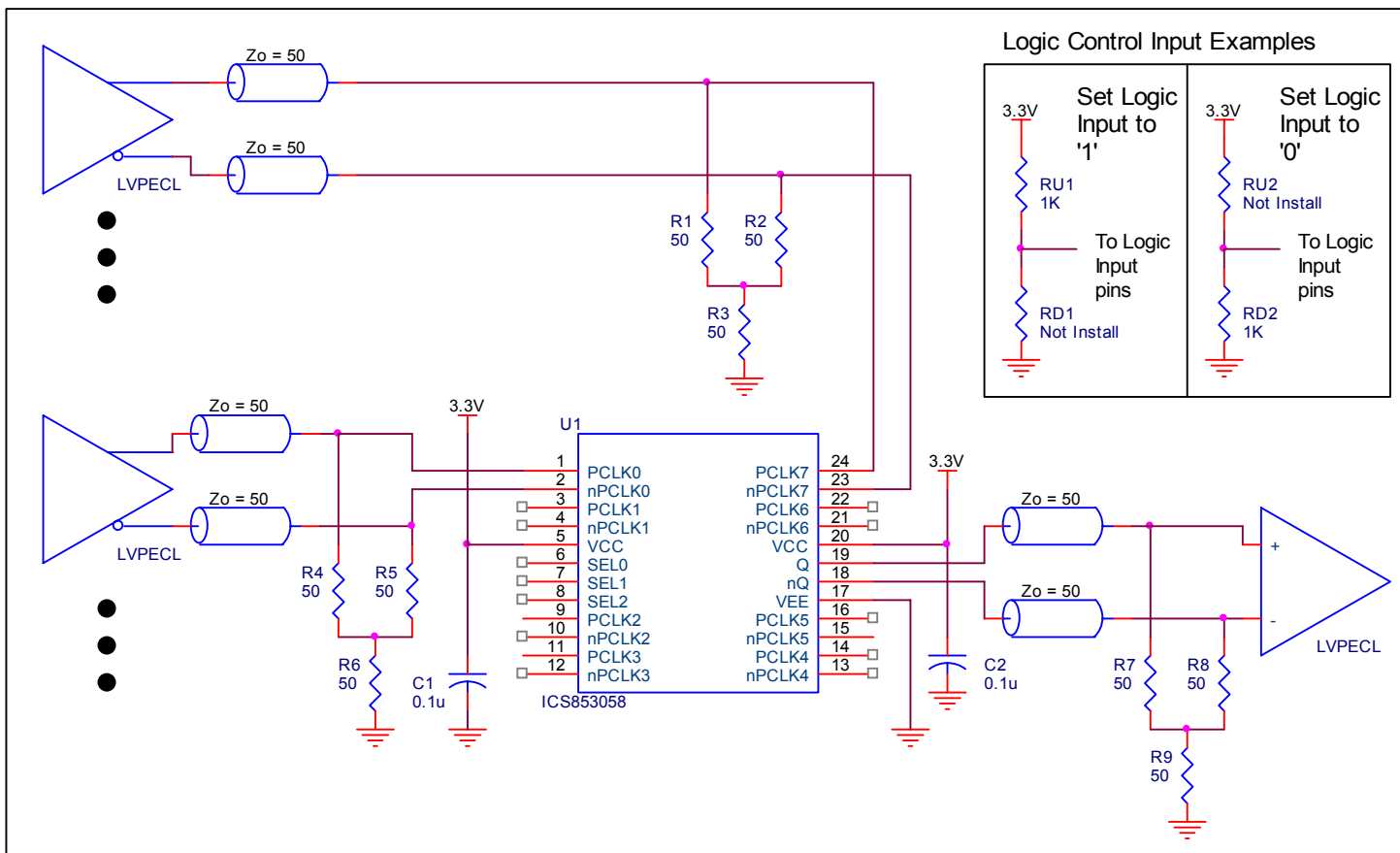

Figure 5. ICS853058 Schematic Example

Power Considerations

This section provides information on power dissipation and junction temperature for the ICS853058. Equations and example calculations are also provided.

1. Power Dissipation.

The total power dissipation for the ICS853058 is the sum of the core power plus the power dissipated in the load(s). The following is the power dissipation for $V_{CC} = 3.3V + 5\% = 3.465V$, which gives worst case results.

NOTE: Please refer to Section 3 for details on calculating power dissipated in the load.

- Power (core)_{MAX} = $V_{CC_MAX} * I_{EE_MAX} = 3.465V * 47mA = \mathbf{162.86mW}$
- Power (outputs)_{MAX} = **30.94mW/Loaded Output pair**

Total Power_{MAX} (3.465V, with all outputs switching) = $162.86mW + 3.94mW = \mathbf{193.8mW}$

2. Junction Temperature.

Junction temperature, T_j , is the temperature at the junction of the bond wire and bond pad and directly affects the reliability of the device. The maximum recommended junction temperature for HiPerClockS devices is 125°C.

The equation for T_j is as follows: $T_j = \theta_{JA} * Pd_total + T_A$

T_j = Junction Temperature

θ_{JA} = Junction-to-Ambient Thermal Resistance

Pd_total = Total Device Power Dissipation (example calculation is in section 1 above)

T_A = Ambient Temperature

In order to calculate junction temperature, the appropriate junction-to-ambient thermal resistance θ_{JA} must be used. Assuming a moderate air flow of 1 meter per second and a multi-layer board, the appropriate value is 65°C/W per Table 6 below.

Therefore, T_j for an ambient temperature of 85°C with all outputs switching is:

$85^\circ C + 0.194W * 65^\circ C/W = 97.6^\circ C$. This is well below the limit of 125°C.

This calculation is only an example. T_j will obviously vary depending on the number of loaded outputs, supply voltage, air flow and the type of board (single layer or multi-layer).

Table 6. Thermal Resistance θ_{JA} for 24 Lead TSSOP, Forced Convection

Meters per Second	θ_{JA} by Velocity		
	0	1	2.5
Multi-Layer PCB, JEDEC Standard Test Boards	70°C/W	65°C/W	62°C/W

3. Calculations and Equations.

The purpose of this section is to derive the power dissipated into the load.

LVPECL output driver circuit and termination are shown in *Figure 6*.

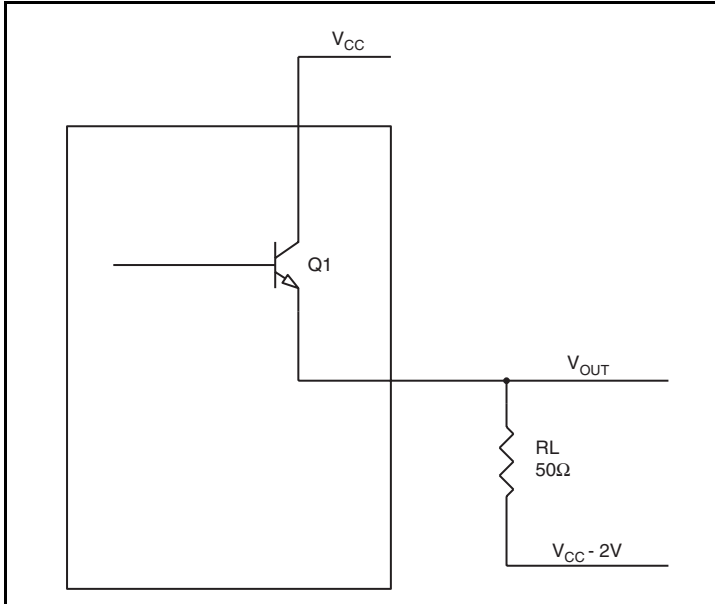

Figure 6. LVPECL Driver Circuit and Termination

To calculate worst case power dissipation into the load, use the following equations which assume a 50Ω load, and a termination voltage of $V_{CC} - 2V$.

- For logic high, $V_{OUT} = V_{OH_MAX} = V_{CC_MAX} - 0.935V$
 $(V_{CC_MAX} - V_{OH_MAX}) = 0.935V$
- For logic low, $V_{OUT} = V_{OL_MAX} = V_{CC_MAX} - 1.67V$
 $(V_{CC_MAX} - V_{OL_MAX}) = 1.67V$

Pd_H is power dissipation when the output drives high.

Pd_L is the power dissipation when the output drives low.

$$Pd_H = [(V_{OH_MAX} - (V_{CC_MAX} - 2V))/R_L] * (V_{CC_MAX} - V_{OH_MAX}) = [(2V - (V_{CC_MAX} - V_{OH_MAX}))/R_L] * (V_{CC_MAX} - V_{OH_MAX}) = [(2V - 0.935V)/50\Omega] * 0.935V = \mathbf{19.92mW}$$

$$Pd_L = [(V_{OL_MAX} - (V_{CC_MAX} - 2V))/R_L] * (V_{CC_MAX} - V_{OL_MAX}) = [(2V - (V_{CC_MAX} - V_{OL_MAX}))/R_L] * (V_{CC_MAX} - V_{OL_MAX}) = [(2V - 1.67V)/50\Omega] * 1.67V = \mathbf{11.2mW}$$

$$\text{Total Power Dissipation per output pair} = Pd_H + Pd_L = \mathbf{30.94mW}$$

Reliability Information

Table 7. θ_{JA} vs. Air Flow Table for a 24 Lead TSSOP

Meters per Second	θ_{JA} by Velocity		
	0	1	2.5
Multi-Layer PCB, JEDEC Standard Test Boards	70°C/W	65°C/W	62°C/W

Transistor Count

The transistor count for ICS853058 is: 326

Package Outline and Package Dimension

Package Outline - G Suffix for 24 Lead TSSOP

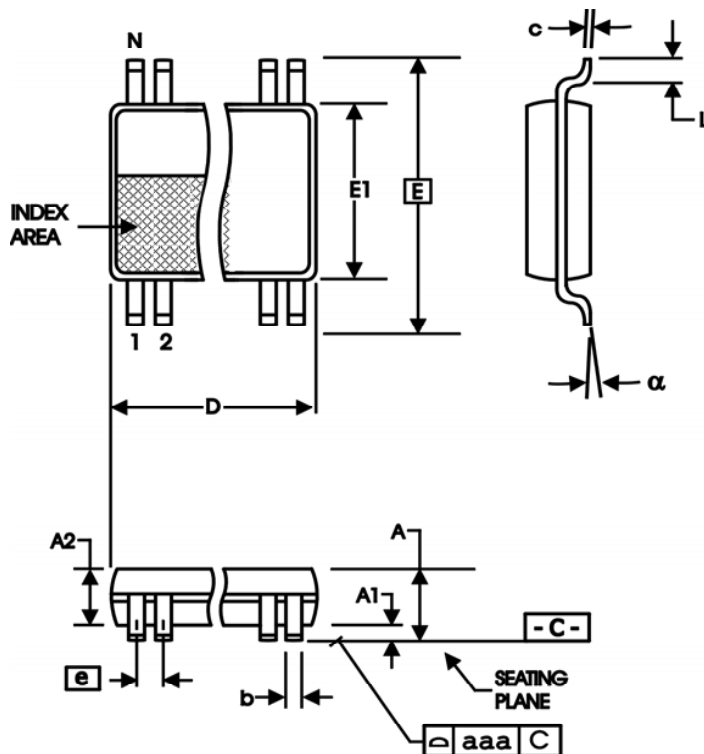

Table 8. Package Dimensions

All Dimensions in Millimeters		
Symbol	Minimum	Maximum
N	24	
A		1.20
A1	0.5	0.15
A2	0.80	1.05
b	0.19	0.30
c	0.09	0.20
D	7.70	7.90
E	6.40 Basic	
E1	4.30	4.50
e	0.65 Basic	
L	0.45	0.75
α	0°	8°
aaa		0.10

Reference Document: JEDEC Publication 95, MO-153

Ordering Information

Table 9. Ordering Information

Part/Order Number	Marking	Package	Shipping Packaging	Temperature
ICS853058AG	ICS853058AG	24 Lead TSSOP	Tube	-40°C to 85°C
ICS853058AGT	ICS853058AG	24 Lead TSSOP	2500 Tape & Reel	-40°C to 85°C
ICS853058AGLF	ICS853058AGL	"Lead-Free" 24 Lead TSSOP	Tube	-40°C to 85°C
ICS853058AGLFT	ICS853058AGL	"Lead-Free" 24 Lead TSSOP	2500 Tape & Reel	-40°C to 85°C

NOTE: Parts that are ordered with an "LF" suffix to the part number are the Pb-Free configuration and are RoHS compliant.

While the information presented herein has been checked for both accuracy and reliability, Integrated Device Technology (IDT) assumes no responsibility for either its use or for the infringement of any patents or other rights of third parties, which would result from its use. No other circuits, patents, or licenses are implied. This product is intended for use in normal commercial and industrial applications. Any other applications, such as those requiring high reliability or other extraordinary environmental requirements are not recommended without additional processing by IDT. IDT reserves the right to change any circuitry or specifications without notice. IDT does not authorize or warrant any IDT product for use in life support devices or critical medical instruments.

Revision History Sheet

Rev	Table	Page	Description of Change	Date
A	T4D T9	4 16	ECL DC Characteristics Table - correct V_{PP} unit of measure from mV to V. Ordering Information Table - added Lead-Free part number.	5/12/08

ICS853058

8:1, DIFFERENTIAL-TO-3.3V OR 2.5V LVPECL/ECL CLOCK MULTIPLEXER

Contact Information:

www.IDT.com

Sales

800-345-7015 (inside USA)
+408-284-8200 (outside USA)
Fax: 408-284-2775
www.IDT.com/go/contactIDT

Technical Support

netcom@idt.com
+480-763-2056

Corporate Headquarters

Integrated Device Technology, Inc.
6024 Silver Creek Valley Road
San Jose, CA 95138
United States
800-345-7015 (inside USA)
+408-284-8200 (outside USA)

