



Chipsmall Limited consists of a professional team with an average of over 10 year of expertise in the distribution of electronic components. Based in Hongkong, we have already established firm and mutual-benefit business relationships with customers from,Europe,America and south Asia,supplying obsolete and hard-to-find components to meet their specific needs.

With the principle of “Quality Parts,Customers Priority,Honest Operation,and Considerate Service”,our business mainly focus on the distribution of electronic components. Line cards we deal with include Microchip,ALPS,ROHM,Xilinx,Pulse,ON,Everlight and Freescale. Main products comprise IC,Modules,Potentiometer,IC Socket,Relay,Connector.Our parts cover such applications as commercial,industrial, and automotives areas.

We are looking forward to setting up business relationship with you and hope to provide you with the best service and solution. Let us make a better world for our industry!



## Contact us

Tel: +86-755-8981 8866 Fax: +86-755-8427 6832

Email & Skype: info@chipsmall.com Web: www.chipsmall.com

Address: A1208, Overseas Decoration Building, #122 Zhenhua RD., Futian, Shenzhen, China





### GENERAL DESCRIPTION



The ICS854057 is a 4:1 or 2:1 LVDS Clock Multiplexer which can operate up to 2GHz and is a member of the HiPerClockS™ family of High Performance Clock Solutions from ICS. The PCLK, nPCLK pairs can accept most standard differential input levels. Internal termination is provided on each differential input pair. The ICS854057 operates using a 2.5V supply voltage. The fully differential architecture and low propagation delay make it ideal for use in high speed multiplexing applications. The select pins have internal pulldown resistors. Leaving one input unconnected (pulled to logic low by the internal resistor) will transform the device into a 2:1 multiplexer. The SEL1 pin is the most significant bit and the binary number applied to the select pins will select the same numbered data input (i.e., 00 selects PCLK0, nPCLK0).

### FEATURES

- High speed differential multiplexer. The device can be configured as either a 4:1 or 2:1 multiplexer
- Single LVDS output
- 4 selectable PCLK, nPCLK inputs with internal termination
- PCLK, nPCLK pairs can accept the following differential input levels: LVPECL, LVDS, CML, SSTL
- Output frequency: >2GHz
- Part-to-part skew: 200ps (maximum)
- Propagation delay: 800ps (maximum)
- Additive phase jitter, RMS: 66fs (typical)
- 2.5V operating supply
- -40°C to 85°C ambient operating temperature
- Available in both, Standard and RoHS/Lead-Free compliant packages

### BLOCK DIAGRAM

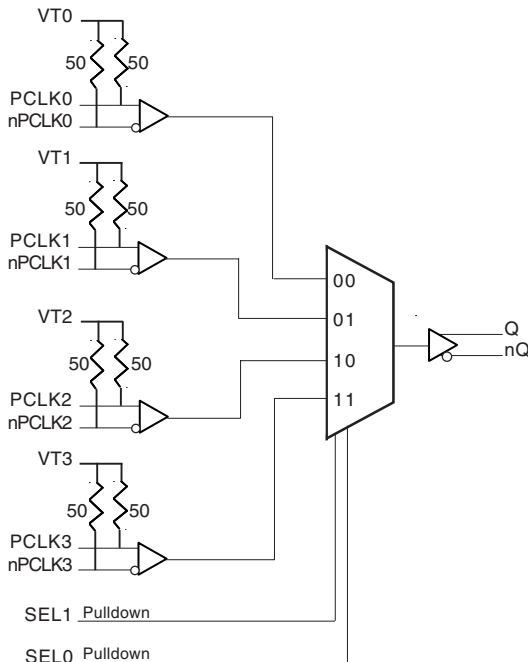

### PIN ASSIGNMENT

V <sub>DD</sub>	1	20	V <sub>DD</sub>
PCLK0	2	19	PCLK3
VT0	3	18	VT3
nPCLK0	4	17	nPCLK3
SEL1	5	16	Q
SEL0	6	15	nQ
PCLK1	7	14	PCLK2
VT1	8	13	VT2
nPCLK1	9	12	nPCLK2
GND	10	11	GND

**ICS854057**  
**20-Lead TSSOP**  
 4.40mm x 6.50mm x 0.925mm body package  
**G Package**  
 Top View



**TABLE 1. PIN DESCRIPTIONS**

Number	Name	Type		Description
1, 20	V <sub>DD</sub>	Power		Positive supply pins.
2	PCLK0	Input		Non-inverting LVPECL differential clock input. R <sub>T</sub> = 50Ω termination to VT0.
3	VT0	Input		Termination input. For LVDS input, leave floating. R <sub>T</sub> = 50Ω termination to VT0.
4	nPCLK0	Input		Inverting LVPECL differential clock input. R <sub>T</sub> = 50Ω termination to VT0
5	SEL1	Input	Pulldown	Clock select input. LVCMOS / LVTTTL interface levels.
6	SEL0	Input	Pulldown	Clock select input. LVCMOS / LVTTTL interface levels.
7	PCLK1	Input		Non-inverting LVPECL differential clock input. R <sub>T</sub> = 50Ω termination to VT1.
8	VT1	Input		Termination input. For LVDS input, leave floating. R <sub>T</sub> = 50Ω termination to VT1.
9	nPCLK1	Input		Inverting LVPECL differential clock input. R <sub>T</sub> = 50Ω termination to VT1.
10, 11	GND	Power		Power supply ground.
12	nPCLK2	Input		Inverting LVPECL differential clock input. R <sub>T</sub> = 50Ω termination to VT2.
13	VT2	Input		Termination input. For LVDS input, leave floating. R <sub>T</sub> = 50Ω termination to VT2.
14	PCLK2	Input		Non-inverting LVPECL differential clock input. R <sub>T</sub> = 50Ω termination to VT2.
15, 16	nQ, Q	Output		Differential output pairs. LVDS interface levels.
17	nPCLK3	Input		Inverting LVPECL differential clock input. R <sub>T</sub> = 50Ω termination to VT3.
18	VT3	Input		Termination input. For LVDS input, leave floating. R <sub>T</sub> = 50Ω termination to VT3.
19	PCLK3	Input		Non-inverting LVPECL differential clock input. R <sub>T</sub> = 50Ω termination to VT3.

NOTE: *Pulldown* refers to internal input resistors. See Table 2, Pin Characteristics, for typical values.

**TABLE 2. PIN CHARACTERISTICS**

Symbol	Parameter	Test Conditions	Minimum	Typical	Maximum	Units
C <sub>IN</sub>	Input Capacitance			1.5		pF
R <sub>PULLDOWN</sub>	Input Pulldown Resistor			50		kΩ
R <sub>T</sub>	Input Termination Resistor			50		Ω

**TABLE 3. CONTROL INPUT FUNCTION TABLE**

Inputs		Clock Out
SEL1	SEL0	PCLKx/nPCLKx
0	0	PCLK0, nPCLK0
0	1	PCLK1, nPCLK1
1	0	PCLK2, nPCLK2
1	1	PCLK3, nPCLK3



### ABSOLUTE MAXIMUM RATINGS

Supply Voltage, $V_{DD}$	4.6V
Inputs, $V_I$	-0.5V to $V_{DD} + 0.5V$
Outputs, $I_O$	
Continuous Current	10mA
Surge Current	15mA
Package Thermal Impedance, $\theta_{JA}$	73.2°C/W (0 lfpm)
Storage Temperature, $T_{STG}$	-65°C to 150°C

NOTE: Stresses beyond those listed under Absolute Maximum Ratings may cause permanent damage to the device. These ratings are stress specifications only. Functional operation of product at these conditions or any conditions beyond those listed in the *DC Characteristics* or *AC Characteristics* is not implied. Exposure to absolute maximum rating conditions for extended periods may affect product reliability.

**TABLE 4A. POWER SUPPLY DC CHARACTERISTICS,  $V_{DD} = 2.5V \pm 5\%$ ,  $T_A = -40^\circ C$  TO  $85^\circ C$**

Symbol	Parameter	Test Conditions	Minimum	Typical	Maximum	Units
$V_{DD}$	Positive Supply Voltage		2.375	2.5	2.625	V
$I_{DD}$	Power Supply Current				60	mA

**TABLE 4B. LVCMOS / LVTTTL DC CHARACTERISTICS,  $V_{DD} = 2.5V \pm 5\%$ ,  $T_A = -40^\circ C$  TO  $85^\circ C$**

Symbol	Parameter	Test Conditions	Minimum	Typical	Maximum	Units
$V_{IH}$	Input High Voltage		$0.7 * V_{DD}$		$V_{DD} + 0.3$	V
$V_{IL}$	Input Low Voltage		-0.3		$0.3 * V_{DD}$	V
$I_{IH}$	Input High Current	SEL0, SEL1 $V_{DD} = V_{IN} = 2.625V$			150	$\mu A$
$I_{IL}$	Input Low Current	SEL0, SEL1 $V_{DD} = 2.625V, V_{IN} = 0V$	-150			$\mu A$

**TABLE 4C. LVPECL DC CHARACTERISTICS,  $V_{DD} = 2.5V \pm 5\%$ ,  $T_A = -40^\circ C$  TO  $85^\circ C$**

Symbol	Parameter	Test Conditions	Minimum	Typical	Maximum	Units
$I_{IH}$	Input High Current	$V_{DD} = V_{IN} = 2.625V$			150	$\mu A$
$I_{IL}$	Input Low Current	$V_{DD} = 2.625V, V_{IN} = 0V$	-150			$\mu A$
$V_{PP}$	Peak-to-Peak Voltage		0.15		1.2	V
$V_{CMR}$	Common Mode Input Voltage; NOTE 1, 2		1.2		$V_{DD}$	V

NOTE 1: Common mode input voltage is defined as  $V_{IH}$ .

NOTE 2: For single ended applications, the maximum input voltage for PCLKx, nPCLKx is  $V_{DD} + 0.3V$ .



**TABLE 4D. LVDS DC CHARACTERISTICS,  $V_{DD} = 2.5V \pm 5\%$ ,  $T_A = -40^\circ C$  TO  $85^\circ C$**

Symbol	Parameter	Test Conditions	Minimum	Typical	Maximum	Units
$V_{OD}$	Differential Output Voltage		225	325	425	mV
$\Delta V_{OD}$	$V_{OD}$ Magnitude Change			4	35	mV
$V_{OS}$	Offset Voltage		1.125	1.25	1.375	V
$\Delta V_{OS}$	$V_{OS}$ Magnitude Change			5	25	mV

**TABLE 5. AC CHARACTERISTICS,  $V_{DD} = 2.5V \pm 5\%$ ,  $T_A = -40^\circ C$  TO  $85^\circ C$**

Symbol	Parameter	Test Conditions	Minimum	Typical	Maximum	Units
$f_{MAX}$	Output Frequency			>2		GHz
$t_{PD}$	Propagation Delay; NOTE 1		300		800	ps
$f_{jit}$	Buffer Additive Phase Jitter, RMS; refer to Additive Phase Jitter Section	622.08MHz, 12kHz - 20MHz		66		fs
$t_{sk(i)}$	Input Skew				40	ps
$t_{sk(pp)}$	Part-to-Part Skew; NOTE 2, 3				200	ps
$t_R / t_F$	Output Rise/Fall Time	20% to 80%	50		250	ps
odc	Output Duty Cycle		47		53	%
		$\leq 700MHz$	49		51	%
$mux_{ISOLATION}$	MUX Isolation	$f = 500MHz$		-55		dBm

NOTE: All parameters are measured at  $f \leq 1.9GHz$  unless noted otherwise.

NOTE 1: Measured from the differential input crossing point to the differential output crossing point.

NOTE 2: Defined as skew between different devices operating at the same supply voltages and with equal load conditions. Using the same type of inputs on each device, the output is measured at the differential cross point.

NOTE 3: This parameter is defined in accordance with JEDEC Standard 65.



### ADDITIVE PHASE JITTER

The spectral purity in a band at a specific offset from the fundamental compared to the power of the fundamental is called the ***dBc Phase Noise***. This value is normally expressed using a Phase noise plot and is most often the specified plot in many applications. Phase noise is defined as the ratio of the noise power present in a 1Hz band at a specified offset from the fundamental frequency to the power value of the fundamental. This ratio is expressed in decibels (dBm) or a ratio of the power in

the 1Hz band to the power in the fundamental. When the required offset is specified, the phase noise is called a ***dBc*** value, which simply means dBm at a specified offset from the fundamental. By investigating jitter in the frequency domain, we get a better understanding of its effects on the desired application over the entire time record of the signal. It is mathematically possible to calculate an expected bit error rate given a phase noise plot.

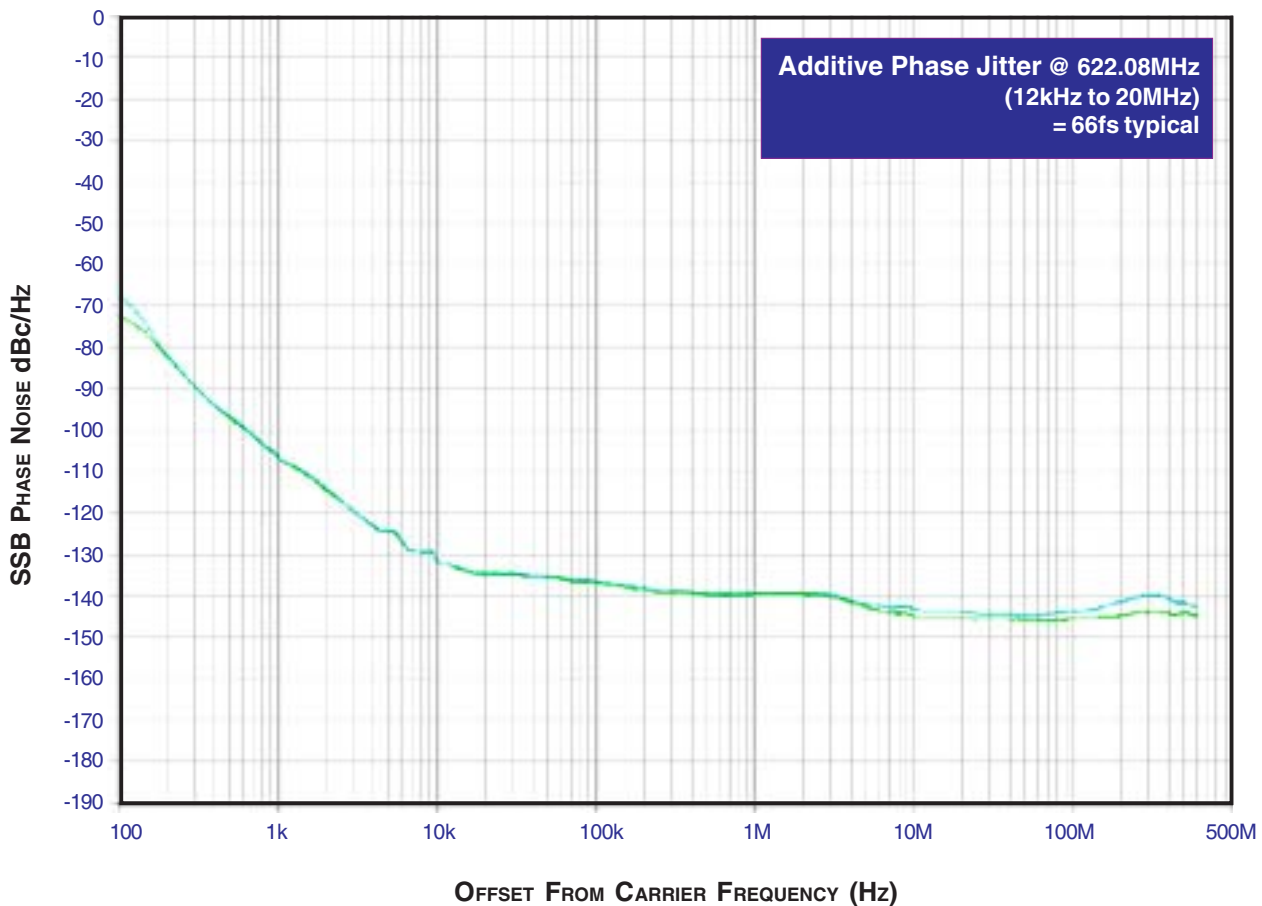

As with most timing specifications, phase noise measurements have issues. The primary issue relates to the limitations of the equipment. Often the noise floor of the equipment is higher than the noise floor of the device. This is illustrated above. The de-

vice meets the noise floor of what is shown, but can actually be lower. The phase noise is dependant on the input source and measurement equipment.



**PARAMETER MEASUREMENT INFORMATION**

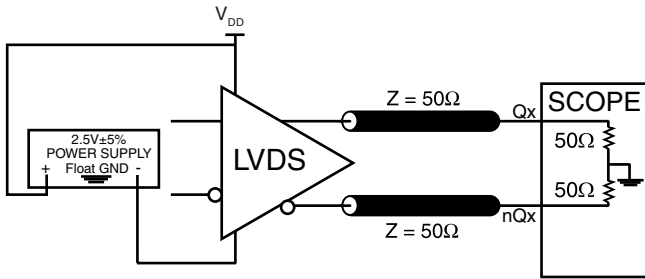

**2.5V OUTPUT LOAD AC TEST CIRCUIT**

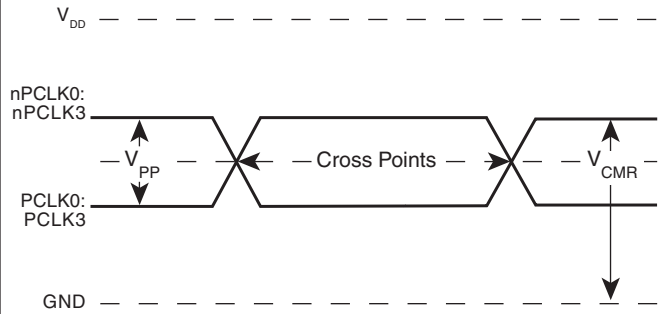

**DIFFERENTIAL INPUT LEVEL**

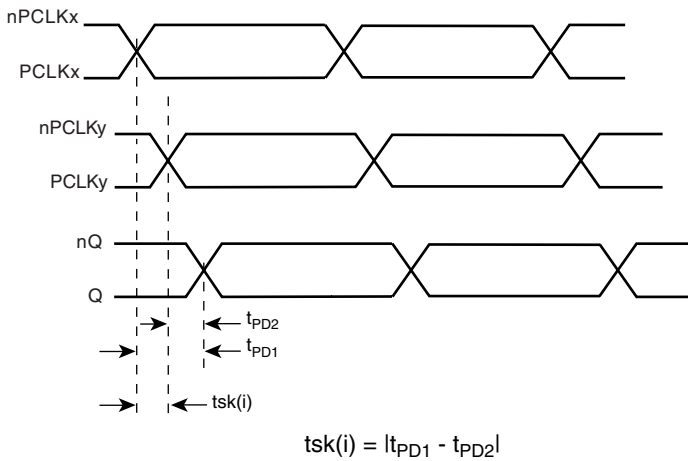

**INPUT SKEW**

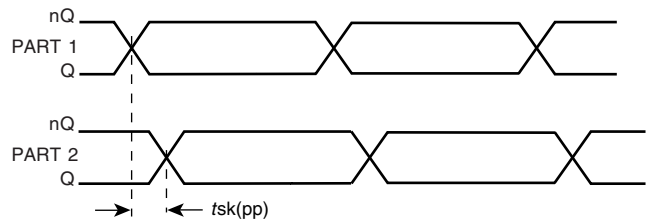

**PART-TO-PART SKEW**

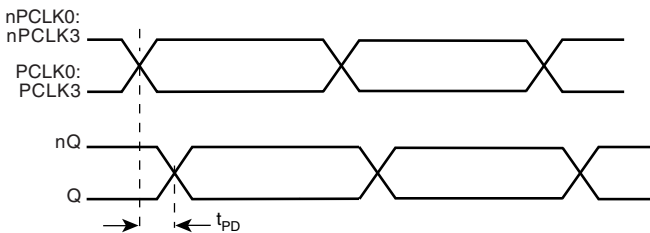

**PROPAGATION DELAY**

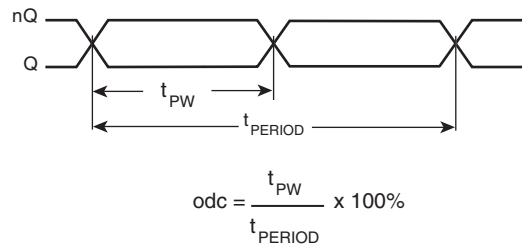

**OUTPUT DUTY CYCLE/PULSE WIDTH/PERIOD**

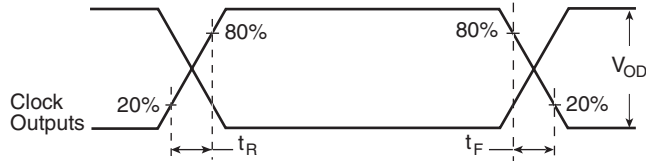

**OUTPUT RISE/FALL TIME**

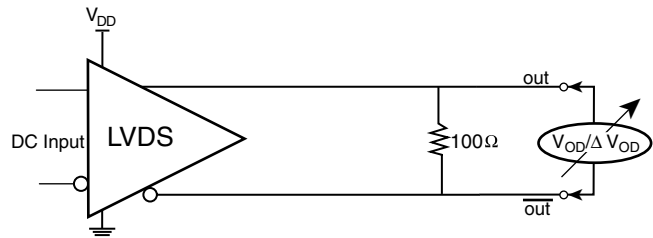

**DIFFERENTIAL OUTPUT VOLTAGE SETUP**

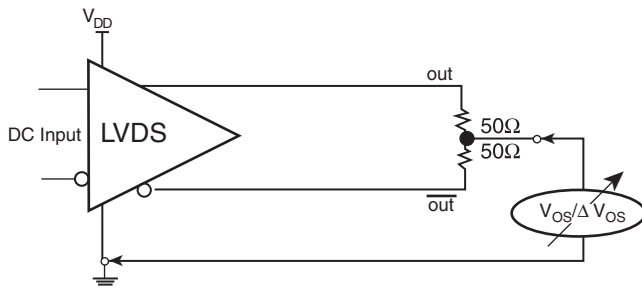

**OFFSET VOLTAGE SETUP**





## APPLICATION INFORMATION

### 2.5V LVDS DRIVER TERMINATION

Figure 1 shows a typical termination for LVDS driver in characteristic impedance of 100Ω differential (50Ω single) transmission line environment. For buffer with multiple LDVS driver, it is recommended to terminate the unused output.

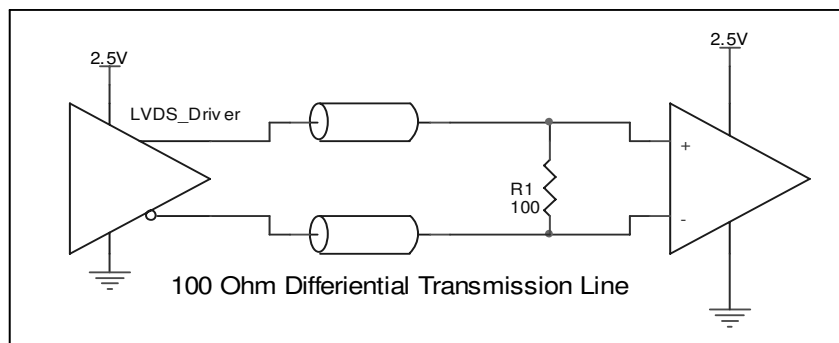

FIGURE 1. TYPICAL LVDS DRIVER TERMINATION

### 2.5V DIFFERENTIAL INPUT WITH BUILT-IN 50Ω TERMINATION UNUSED INPUT HANDLING

To prevent oscillation and to reduce noise, it is recommended to have pull up and pull down connected to true and complement of the unused input as shown in Figure 2.

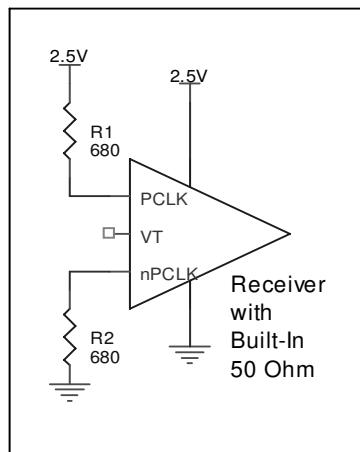

FIGURE 2. UNUSED INPUT HANDLING



### LVPECL INPUT WITH BUILT-IN 50Ω TERMINATIONS INTERFACE

The PCLK /nPCLK with built-in 50Ω terminations accepts LVDS, LVPECL, LVHSTL, CML, SSTL and other differential signals. Both  $V_{SWING}$  and  $V_{OH}$  must meet the  $V_{PP}$  and  $V_{CMR}$  input requirements. Figures 3A to 3E show interface examples for the HiPerClockS PCLK/nPCLK input with built-in

50Ω terminations driven by the most common driver types. The input interfaces suggested here are examples only. If the driver is from another vendor, use their termination recommendation. Please consult with the vendor of the driver component to confirm the driver termination requirements.

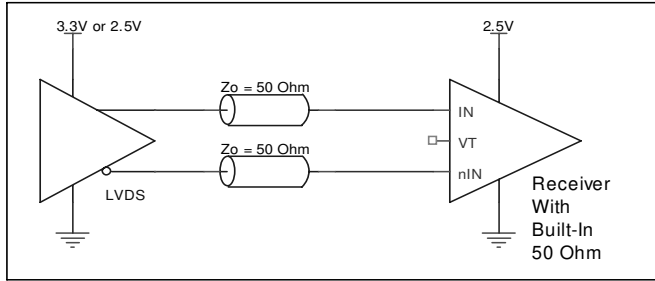

**FIGURE 3A. HiPerClockS PCLK/nPCLK INPUT WITH BUILT-IN 50Ω DRIVEN BY AN LVDS DRIVER**

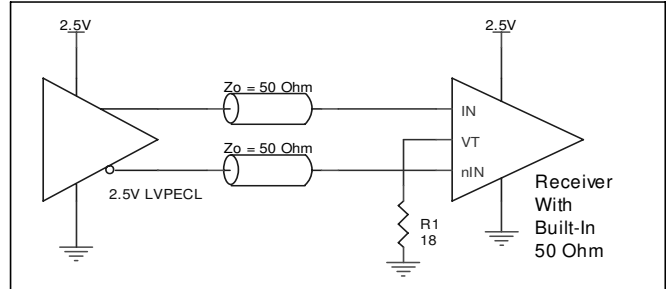

**FIGURE 3B. HiPerClockS PCLK/nPCLK INPUT WITH BUILT-IN 50Ω DRIVEN BY AN LVPECL DRIVER**

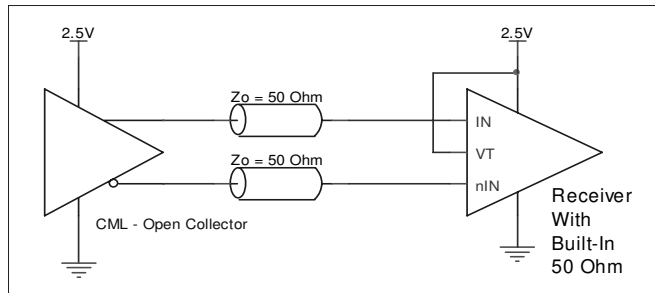

**FIGURE 3C. HiPerClockS PCLK/nPCLK INPUT WITH BUILT-IN 50Ω DRIVEN BY AN OPEN COLLECTOR CML DRIVER**

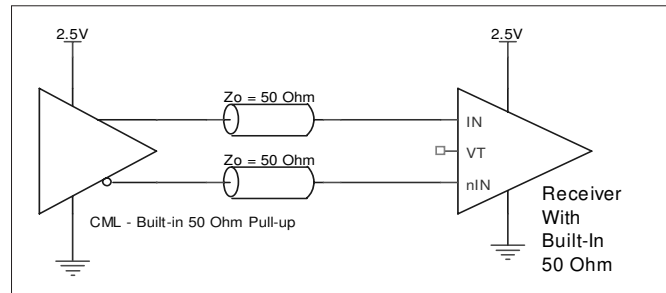

**FIGURE 3D. HiPerClockS PCLK/nPCLK INPUT WITH BUILT-IN 50Ω DRIVEN BY A CML DRIVER WITH BUILT-IN 50Ω PULLUP**

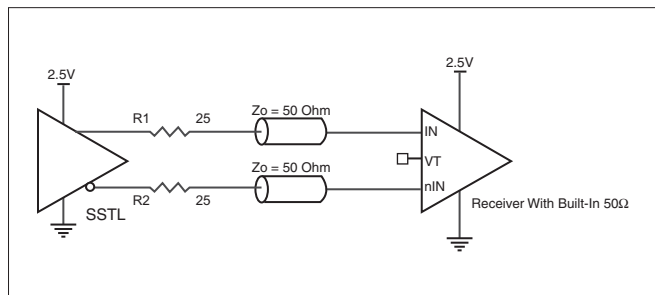

**FIGURE 3E. HiPerClockS PCLK/nPCLK INPUT WITH BUILT-IN 50Ω DRIVEN BY AN SSTL DRIVER**



### RECOMMENDATIONS FOR UNUSED INPUT AND OUTPUT PINS

#### INPUTS:

##### PCLK/nPCLK INPUT:

For applications not requiring the use of a differential input, both the PCLK and nPCLK pins can be left floating. Though not required, but for additional protection, a 1kΩ resistor can be tied from PCLK to ground.

#### OUTPUTS:

##### LVDS OUTPUT

All unused LVDS outputs can be left floating. We recommend that there is no trace attached. Both sides of the differential output pair should either be left floating or terminated.

### SCHEMATIC EXAMPLE

Figure 4 shows a schematic example of the ICS854057. In this example, the PCLK0/nPCLK0 and PCLK1/nPCLK1 inputs are

used. The decoupling capacitors should be physically located near the power pin.

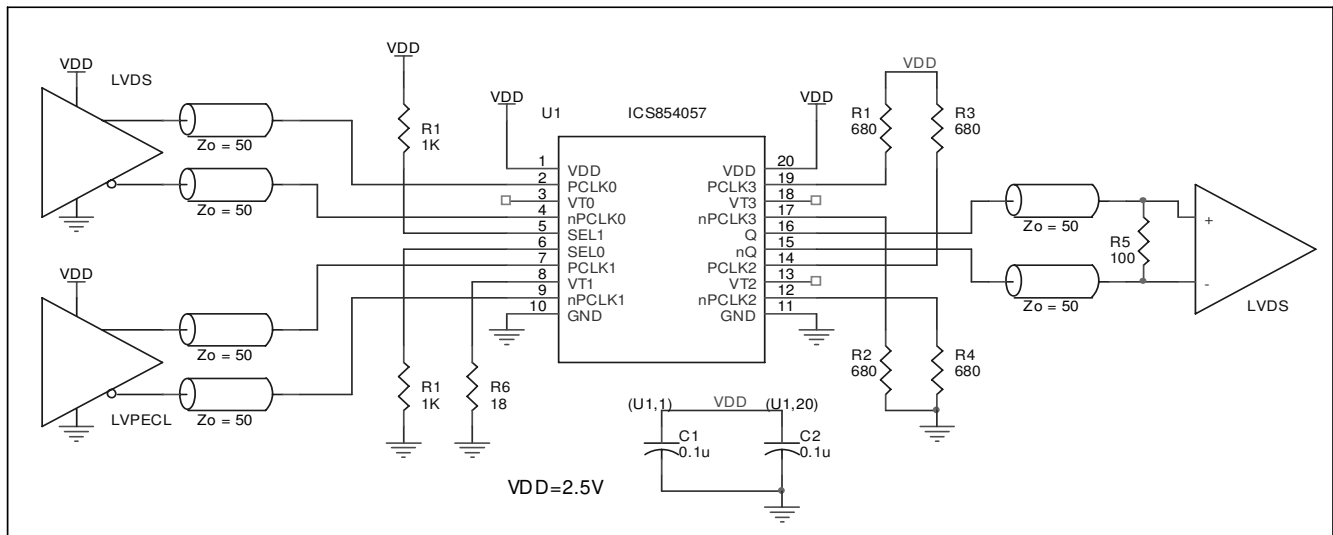

FIGURE 4. EXAMPLE ICS854057 LVDS SCHEMATIC



## RELIABILITY INFORMATION

TABLE 7.  $\theta_{JA}$  vs. AIR FLOW TABLE FOR 20 LEAD TSSOP

$\theta_{JA}$ by Velocity (Linear Feet per Minute)			
	0	200	500
Single-Layer PCB, JEDEC Standard Test Boards	114.5°C/W	98.0°C/W	88.0°C/W
Multi-Layer PCB, JEDEC Standard Test Boards	73.2°C/W	66.6°C/W	63.5°C/W

**NOTE:** Most modern PCB designs use multi-layered boards. The data in the second row pertains to most designs.

### TRANSISTOR COUNT

The transistor count for ICS854057 is: 346



PACKAGE OUTLINE - G SUFFIX FOR 20 LEAD TSSOP

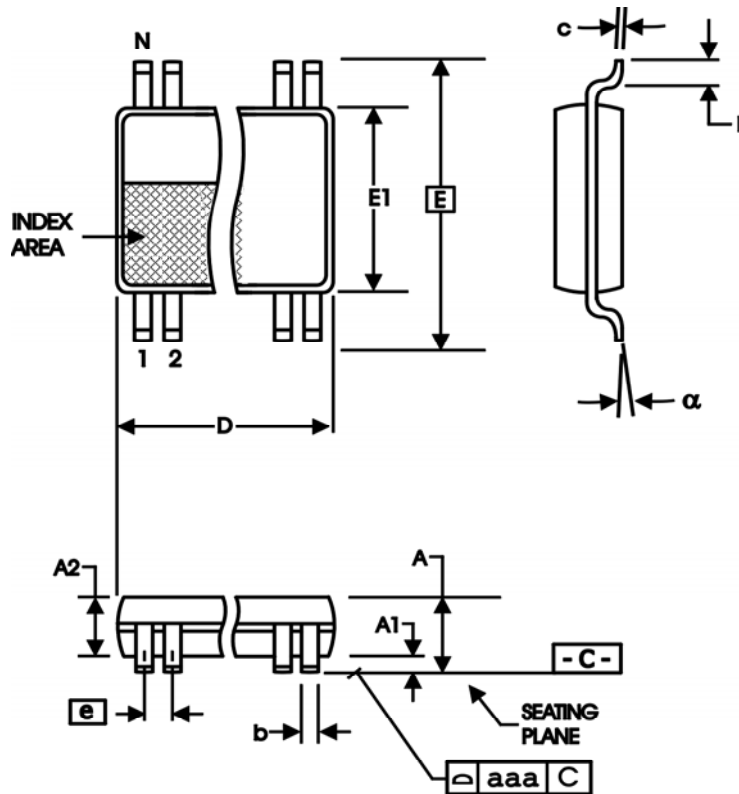

TABLE 8. PACKAGE DIMENSIONS

SYMBOL	Millimeters	
	Minimum	Maximum
N	20	
A	--	1.20
A1	0.05	0.15
A2	0.80	1.05
b	0.19	0.30
c	0.09	0.20
D	6.40	6.60
E	6.40 BASIC	
E1	4.30	4.50
e	0.65 BASIC	
L	0.45	0.75
α	0°	8°
aaa	--	0.10

Reference Document: JEDEC Publication 95, MO-153



Integrated  
Circuit  
Systems, Inc.

# ICS854057

## 4:1 OR 2:1 LVDS CLOCK MULTIPLEXER WITH INTERNAL INPUT TERMINATION

**TABLE 9. ORDERING INFORMATION**

Part/Order Number	Marking	Package	Shipping Packaging	Temperature
854057AG	ICS854057AG	20 lead TSSOP	tube	-40°C to 85°C
854057AGT	ICS854057AG	20 lead TSSOP	2500 tape & reel	-40°C to 85°C
854057AGLFT	ICS854057AGL	20 lead "Lead-Free" TSSOP	tube	-40°C to 85°C
854057AGLFT	ICS854057AGL	20 lead "Lead-Free" TSSOP	2500 tape & reel	-40°C to 85°C

NOTE: Parts that are ordered with an "LF" suffix to the part number are the Pb-Free configuration and are RoHS compliant.

The aforementioned trademark, HiPerClockS™ is a trademark of Integrated Circuit Systems, Inc. or its subsidiaries in the United States and/or other countries. While the information presented herein has been checked for both accuracy and reliability, Integrated Circuit Systems, Incorporated (ICS) assumes no responsibility for either its use or for infringement of any patents or other rights of third parties, which would result from its use. No other circuits, patents, or licenses are implied. This product is intended for use in normal commercial and industrial applications. Any other applications such as those requiring high reliability or other extraordinary environmental requirements are not recommended without additional processing by ICS. ICS reserves the right to change any circuitry or specifications without notice. ICS does not authorize or warrant any ICS product for use in life support devices or critical medical instruments.