



Chipsmall Limited consists of a professional team with an average of over 10 year of expertise in the distribution of electronic components. Based in Hongkong, we have already established firm and mutual-benefit business relationships with customers from,Europe,America and south Asia,supplying obsolete and hard-to-find components to meet their specific needs.

With the principle of "Quality Parts,Customers Priority,Honest Operation,and Considerate Service",our business mainly focus on the distribution of electronic components. Line cards we deal with include Microchip,ALPS,ROHM,Xilinx,Pulse,ON,Everlight and Freescale. Main products comprise IC,Modules,Potentiometer,IC Socket,Relay,Connector.Our parts cover such applications as commercial,industrial, and automotives areas.

We are looking forward to setting up business relationship with you and hope to provide you with the best service and solution. Let us make a better world for our industry!



## Contact us

Tel: +86-755-8981 8866 Fax: +86-755-8427 6832

Email & Skype: info@chipsmall.com Web: www.chipsmall.com

Address: A1208, Overseas Decoration Building, #122 Zhenhua RD., Futian, Shenzhen, China





# LOW SKEW, 1-TO-4 DIFFERENTIAL-TO-CML FANOUT BUFFER

# ICS858020

## General Description



The ICS858020 is a high speed 1-to-4 Differential-to-Open-Collector Output Fanout Buffer and is a member of the HiPerClockS™ family of high performance clock solutions from IDT. The ICS858020 uses an open-collector output structure which requires the termination of the output by 50Ω to V<sub>CC</sub>. The ICS858020 is optimized for high speed and very low output skew, making it suitable for use in demanding applications such as SONET, 1 Gigabit and 10 Gigabit Ethernet, and Fibre Channel. The internally terminated differential input and VREF\_AC pin allow other differential signal families such as LVDS, LVHSTL and Open Collector Output (OC) to be easily interfaced to the input with minimal use of external components. The ICS858020 is packaged in a small 3mm x 3mm 16-pin VFQFN package which makes it ideal for use in space-constrained applications.

## Features

- Four differential CML outputs
- One LVPECL differential clock input
- IN/nIN pair can accept the following differential input levels: LVPECL, LVDS, CML, SSTL
- Maximum output frequency: 3.2GHz
- Output skew: 30ps (maximum)
- Part-to-part skew: 225ps (maximum)
- Additive phase jitter, RMS: <0.3ps (typical)
- Propagation delay: 600ps (maximum)
- Operating voltage supply range: V<sub>CC</sub> = 2.375V to 3.63V, V<sub>EE</sub> = 0V
- -40°C to 85°C ambient operating temperature
- Available in both standard (RoHS 5) and lead-free (RoHS 6) packages

## Block Diagram

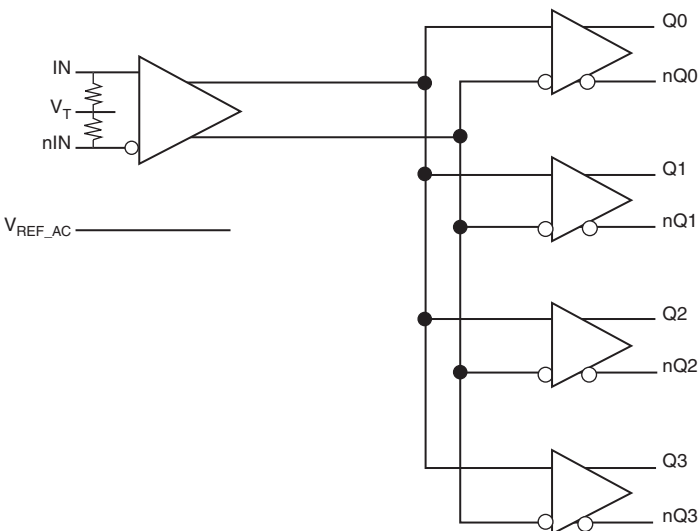

## Pin Assignment

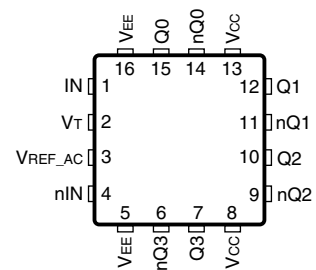

**ICS858020**  
**16-Lead VFQFN**  
**3mm x 3mm x 0.925mm package body**  
**K Package**  
**Top View**

**Table 1. Pin Descriptions**

Number	Name	Type	Description
1	IN	Input	Non-inverting differential LVPECL clock input. This input internally terminates with $50\Omega$ to the $V_T$ pin.
2	$V_T$	Input	Termination input.
3	$V_{REF\_AC}$	Output	Reference voltage for AC-coupled applications. This output biases to $V_{CC} - 1.38V$ .
4	nIN	Input	Inverting differential LVPECL clock input. This input internally terminates with $50\Omega$ to the $V_T$ pin.
5, 16	$V_{EE}$	Power	Negative supply pins.
6, 7	nQ3, Q3	Output	Differential output pair. CML interface levels.
8, 13	$V_{CC}$	Power	Positive supply pins.
9, 10	nQ2, Q2	Output	Differential output pair. CML interface levels.
11, 12	nQ1, Q1	Output	Differential output pair. CML interface levels.
14, 15	nQ0, Q0	Output	Differential output pair. CML interface levels.

## Absolute Maximum Ratings

NOTE: Stresses beyond those listed under *Absolute Maximum Ratings* may cause permanent damage to the device. These ratings are stress specifications only. Functional operation of product at these conditions or any conditions beyond those listed in the *DC Characteristics* or *AC Characteristics* is not implied. Exposure to absolute maximum rating conditions for extended periods may affect product reliability.

Item	Rating
Supply Voltage, $V_{CC}$	4.6V (CML mode, $V_{EE} = 0V$ )
Inputs, $V_I$	-0.5V to $V_{CC} + 0.5V$
Outputs, $I_O$ Continuous Current Surge Current	20mA 40mA
Input Current, IN/nIN	+50mA
$V_T$ Current, $I_{VT}$	+100mA
Input Sink/Source, $I_{REF\_AC}$	+0.5mA
Operating Temperature Range, $T_A$	-40°C to 85°C
Storage Temperature, $T_{STG}$	-65°C to 150°C
Package Thermal Impedance, $\theta_{JA}$ (Junction-to-Ambient)	51.5°C/W (0 lfpm)

## DC Electrical Characteristics

**Table 2A. Power Supply DC Characteristics,  $V_{CC} = 2.375V$  to  $3.63V$ ,  $V_{EE} = 0V$ ,  $T_A = -40^\circ C$  to  $85^\circ C$** 

Symbol	Parameter	Test Conditions	Minimum	Typical	Maximum	Units
$V_{CC}$	Positive Supply Voltage		2.375	3.3	3.63	V
$I_{EE}$	Power Supply Current				135	mA

**Table 2B. DC Characteristics**,  $V_{CC} = 2.375V$  to  $3.63V$ ,  $V_{EE} = 0V$ ,  $T_A = -40^{\circ}C$  to  $85^{\circ}C$ 

Symbol	Parameter	Test Conditions	Minimum	Typical	Maximum	Units
$R_{IN}$	Differential Input Resistance	IN/nIN	40	50	60	$\Omega$
$V_{IH}$	Input High Voltage	IN/nIN	1.2		$V_{CC}$	V
$V_{IL}$	Input Low Voltage	IN/nIN	0		$V_{IH} - 0.15$	V
$V_{IN}$	Input Voltage Swing; NOTE 1		0.15		2.8	V
$V_{DIFF\_IN}$	Differential Input Voltage Swing		0.3		3.4	V
$V_{T\_IN}$	IN-to- $V_T$ Voltage				1.5	V
$V_{REF\_AC}$	Reference Voltage		$V_{CC} - 1.5$	$V_{CC} - 1.4$	$V_{CC} - 1.3$	V

NOTE 1: Refer to Parameter Measurement Information, *Input Voltage Swing Diagram*.

**Table 2C. CML DC Characteristics**,  $V_{CC} = 2.375V$  to  $3.63V$ ,  $V_{EE} = 0V$ ,  $T_A = -40^{\circ}C$  to  $85^{\circ}C$ 

Symbol	Parameter	Test Conditions	Minimum	Typical	Maximum	Units
$V_{OH}$	Output High Voltage; NOTE 1		$V_{CC} - 0.020$	$V_{CC} - 0.010$	$V_{CC}$	V
$V_{OUT}$	Output Voltage Swing		325	400		mV
$V_{DIFF\_OUT}$	Differential Output Voltage Swing		650	800		mV
$R_{OUT}$	Output Source Impedance		40	50	60	$\Omega$

NOTE 1: Outputs terminated with  $100\Omega$  across differential output pair.

## AC Electrical Characteristics

**Table 3. AC Characteristics**,  $V_{CC} = 0V$ ;  $V_{EE} = -3.6V$  to  $-2.375V$  or,  $V_{CC} = 2.375V$  to  $3.6V$ ;  $V_{EE} = 0V$ ,  $T_A = -40^{\circ}C$  to  $85^{\circ}C$ 

Parameter	Symbol	Test Conditions	Minimum	Typical	Maximum	Units
$f_{MAX}$	Output Frequency				3.2	GHz
$t_{PD}$	Propagation Delay, Differential; NOTE 1		350		575	ps
$t_{sk(o)}$	Output Skew; NOTE 2, 4			15	30	ps
$t_{sk(pp)}$	Part-to-Part Skew; NOTE 3, 4				225	ps
$f_{jit}$	Buffer Additive Phase Jitter, RMS; refer to Additive Phase Jitter Section	155.52MHz @ 3.3V, Integration Range: 12kHz – 20MHz		<0.03		fs
$t_R / t_F$	Output Rise/Fall Time	20% to 80%	60		180	ps

All parameters characterized at  $\leq 1.2GHz$  unless otherwise noted.

$R_L = 100\Omega$  after each output pair.

Parameter limits are design target specs.

NOTE 1: Measured from the differential input crossing point to the differential output crossing point.

NOTE 2: Defined as skew between outputs at the same supply voltage and with equal load conditions.

Measured at the output differential cross points.

NOTE 3: Defined as skew between outputs on different devices operating at the same supply voltage and with equal load conditions.

Using the same type of inputs on each device, the outputs are measured at the differential cross points.

NOTE 4: This parameter is defined in accordance with JEDEC Standard 65.



## Additive Phase Jitter

The spectral purity in a band at a specific offset from the fundamental compared to the power of the fundamental is called the ***dBc Phase Noise***. This value is normally expressed using a Phase noise plot and is most often the specified plot in many applications. Phase noise is defined as the ratio of the noise power present in a 1Hz band at a specified offset from the fundamental frequency to the power value of the fundamental. This ratio is expressed in decibels (dBm) or a ratio of the power in the 1Hz band

to the power in the fundamental. When the required offset is specified, the phase noise is called a ***dBc*** value, which simply means dBm at a specified offset from the fundamental. By investigating jitter in the frequency domain, we get a better understanding of its effects on the desired application over the entire time record of the signal. It is mathematically possible to calculate an expected bit error rate given a phase noise plot.

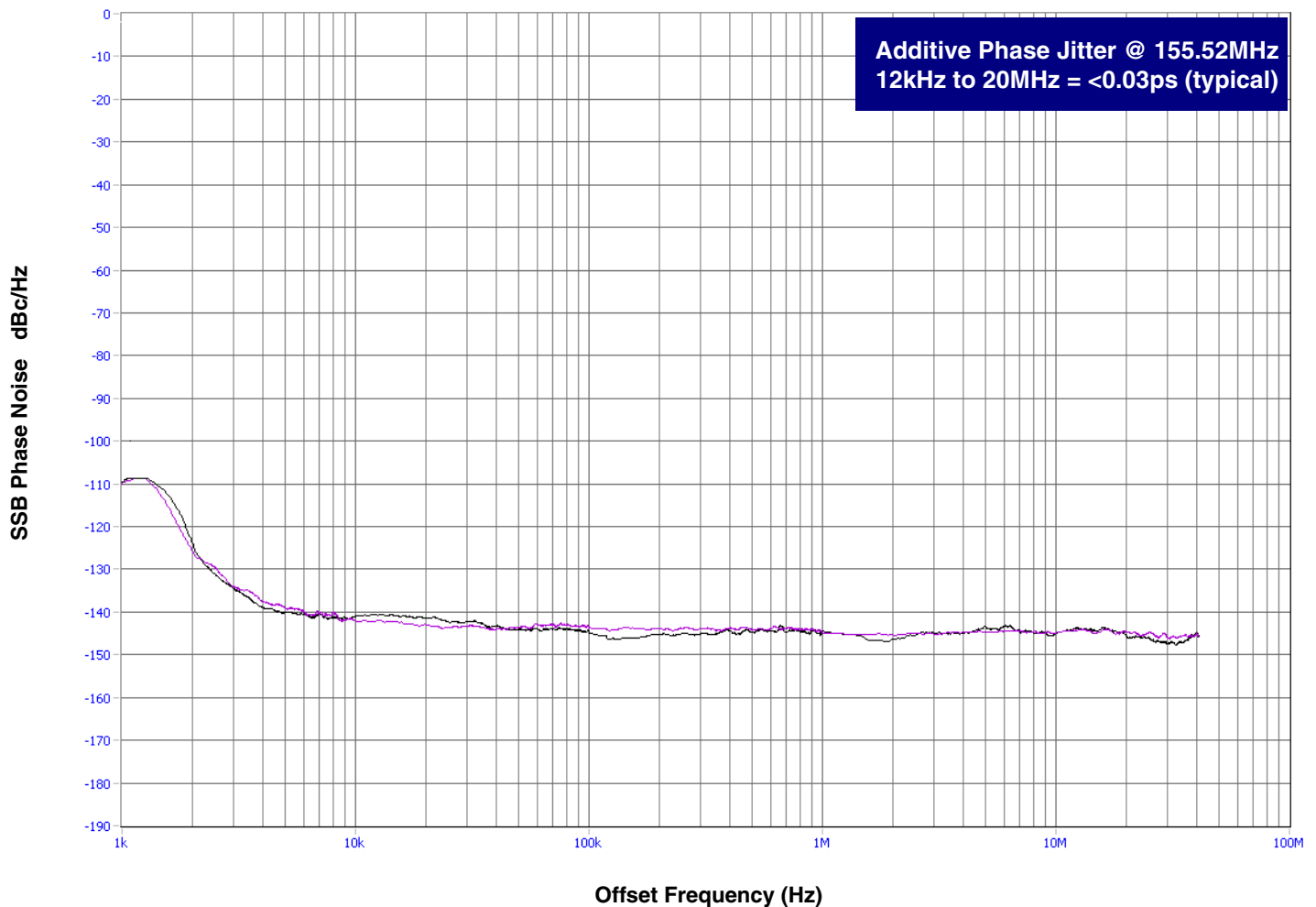

As with most timing specifications, phase noise measurements has issues relating to the limitations of the equipment. Often the noise floor of the equipment is higher than the noise floor of the

device. This is illustrated above. The device meets the noise floor of what is shown, but can actually be lower. The phase noise is dependent on the input source and measurement equipment.

### Parameter Measurement Information

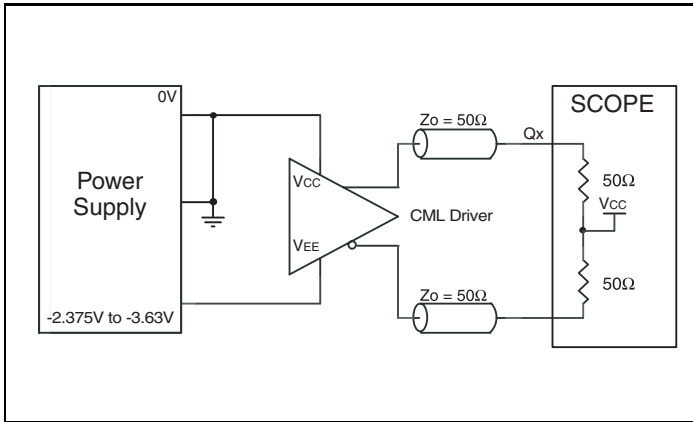

Open Collector Output Load AC Test Circuit

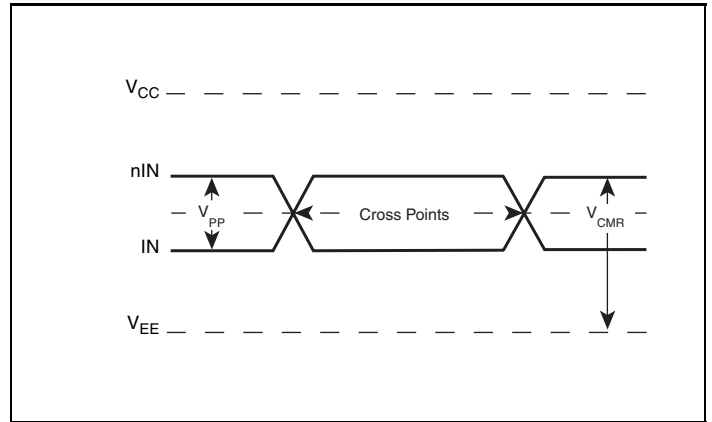

Differential Input Level

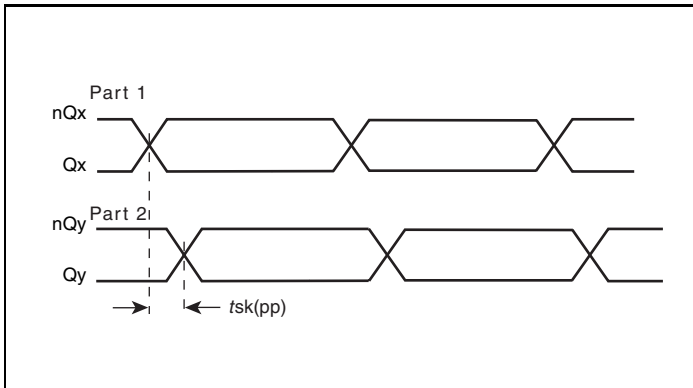

Part-to-Part Skew

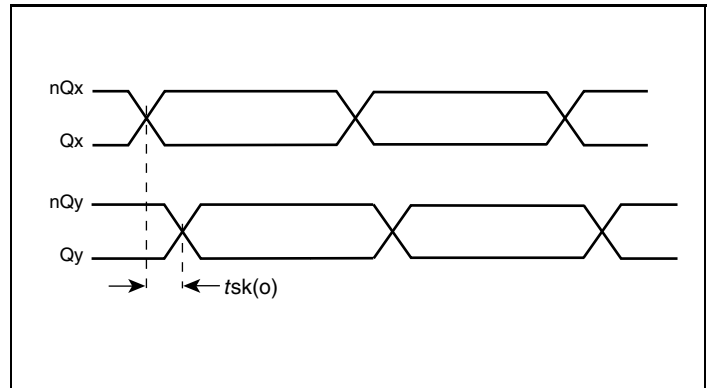

Output Skew

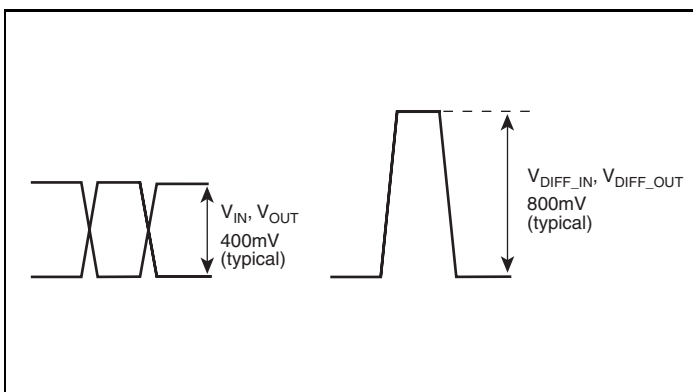

Single-ended & Differential Input Voltage Swing

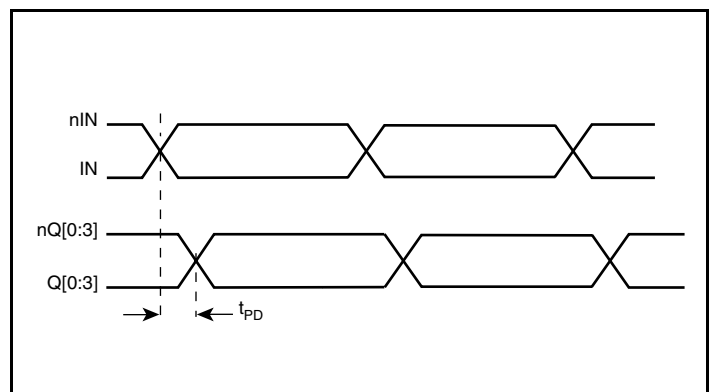

Propagation Delay

## Parameter Measurement Information, continued

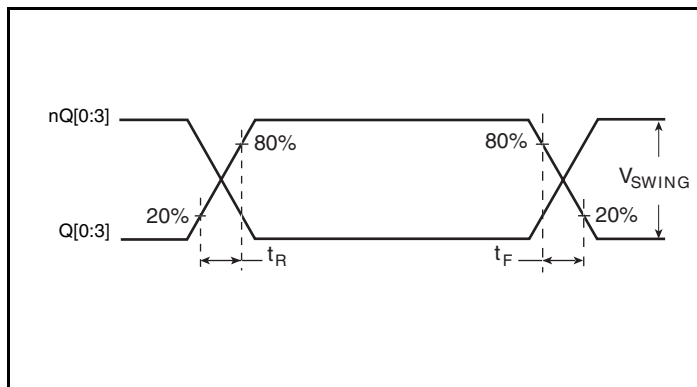

Output Rise/Fall Time

## Application Information

### Recommendations for Unused Output Pins

#### Outputs:

##### CML Outputs

All unused CML outputs can be left floating. We recommend that there is no trace attached. Both sides of the differential output pair should either be left floating or terminated.

### 3.3V Differential Input with Built-In $50\Omega$ Termination Interface

The IN /nIN with built-in  $50\Omega$  terminations accept LVDS, LVPECL, LVHSTL, CML, SSTL and other differential signals. Both signals must meet the  $V_{IN}$  and  $V_{IH}$  input requirements. *Figures 1A to 1c* show interface examples for the HiPerClockS IN/nIN input with built-in  $50\Omega$  terminations driven by the most common driver types.

The input interfaces suggested here are examples only. If the driver is from another vendor, use their termination recommendation. Please consult with the vendor of the driver component to confirm the driver termination requirements.

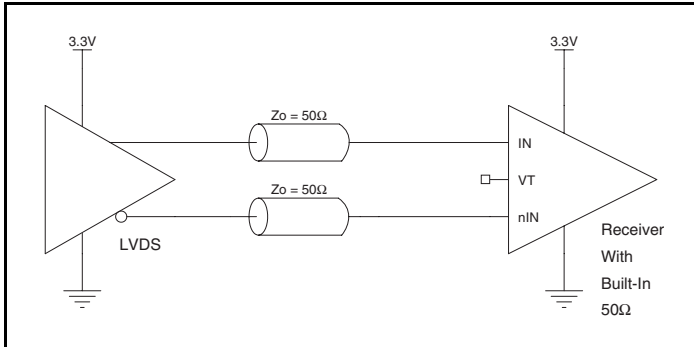

**Figure 1A. HiPerClockS IN/nIN Input with Built-In  $50\Omega$  Driven by an LVDS Driver**

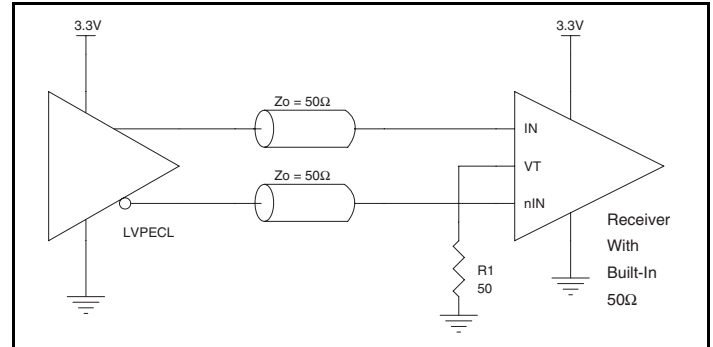

**Figure 1B. HiPerClockS IN/nIN Input with Built-In  $50\Omega$  Driven by an LVPECL Driver**

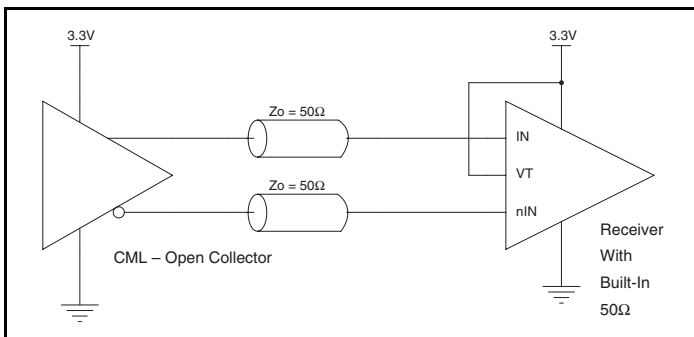

**Figure 1C. HiPerClockS IN/nIN Input with Built-In  $50\Omega$  Driven by a CML Driver**

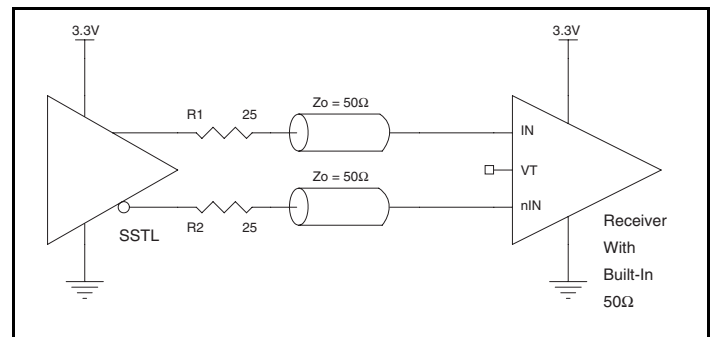

**Figure 1D. HiPerClockS IN/nIN Input with Built-In  $50\Omega$  Driven by an SSTL Driver**



## 2.5V LVPECL Input with Built-In 50Ω Termination Interface

The IN /nIN with built-in 50Ω terminations accept LVDS, LVPECL, LVHSTL, CML, SSTL and other differential signals. Both signals must meet the  $V_{IN}$  and  $V_{IH}$  input requirements. Figures 2A to 2D show interface examples for the HiPerClockS IN/nIN with built-in 50Ω termination input driven by the most common driver types.

The input interfaces suggested here are examples only. If the driver is from another vendor, use their termination recommendation. Please consult with the vendor of the driver component to confirm the driver termination requirements.

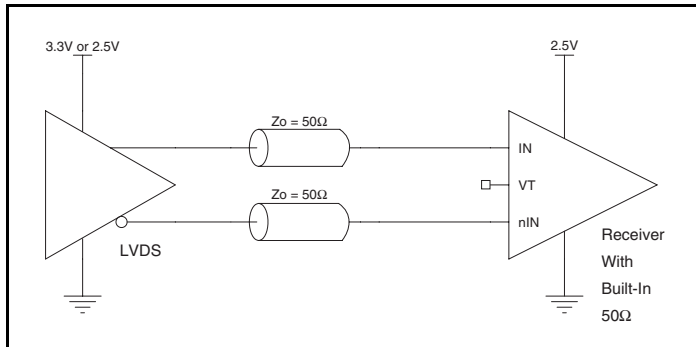

Figure 2A. HiPerClockS IN/nIN Input with Built-In 50Ω Driven by an LVDS Driver

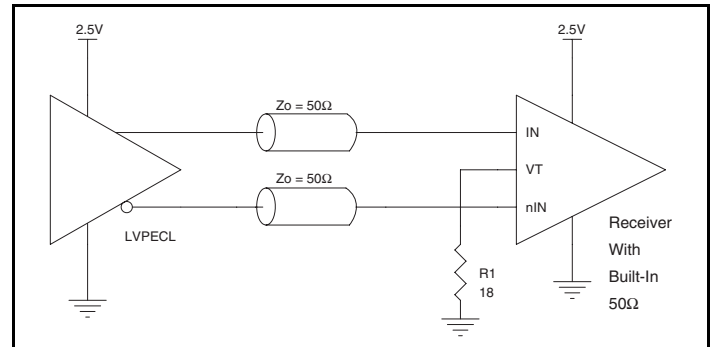

Figure 2B. HiPerClockS IN/nIN Input with Built-In 50Ω Driven by an LVPECL Driver

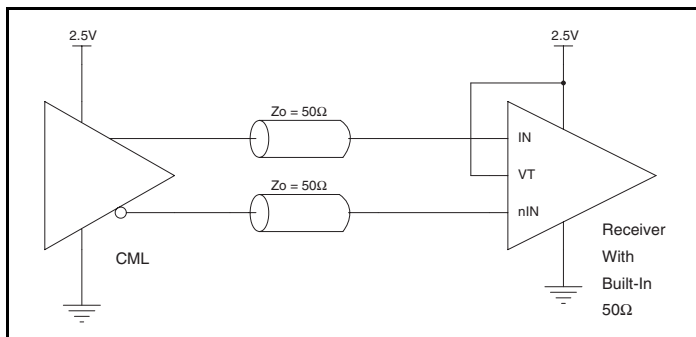

Figure 2C. HiPerClockS IN/nIN Input with Built-In 50Ω Driven by a CML Driver

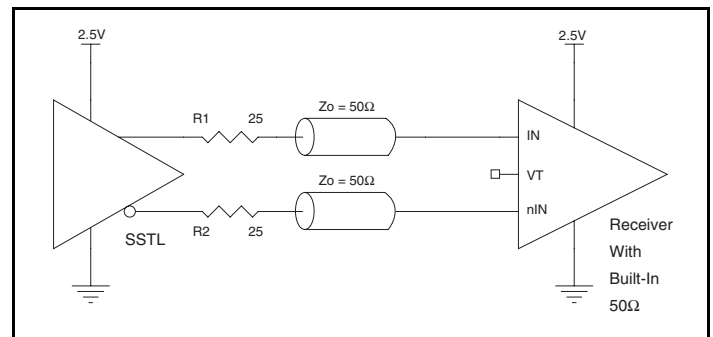

Figure 2D. HiPerClockS IN/nIN Input with Built-In 50Ω Driven by an SSTL Driver

## VFQFN EPAD Thermal Release Path

In order to maximize both the removal of heat from the package and the electrical performance, a land pattern must be incorporated on the Printed Circuit Board (PCB) within the footprint of the package corresponding to the exposed metal pad or exposed heat slug on the package, as shown in *Figure 3*. The solderable area on the PCB, as defined by the solder mask, should be at least the same size/shape as the exposed pad/slug area on the package to maximize the thermal/electrical performance. Sufficient clearance should be designed on the PCB between the outer edges of the land pattern and the inner edges of pad pattern for the leads to avoid any shorts.

While the land pattern on the PCB provides a means of heat transfer and electrical grounding from the package to the board through a solder joint, thermal vias are necessary to effectively conduct from the surface of the PCB to the ground plane(s). The land pattern must be connected to ground through these vias. The vias act as “heat pipes”. The number of vias (i.e. “heat pipes”) are

application specific and dependent upon the package power dissipation as well as electrical conductivity requirements. Thus, thermal and electrical analysis and/or testing are recommended to determine the minimum number needed. Maximum thermal and electrical performance is achieved when an array of vias is incorporated in the land pattern. It is recommended to use as many vias connected to ground as possible. It is also recommended that the via diameter should be 12 to 13mils (0.30 to 0.33mm) with 1oz copper via barrel plating. This is desirable to avoid any solder wicking inside the via during the soldering process which may result in voids in solder between the exposed pad/slug and the thermal land. Precautions should be taken to eliminate any solder voids between the exposed heat slug and the land pattern. Note: These recommendations are to be used as a guideline only. For further information, please refer to the Application Note on the Surface Mount Assembly of Amkor’s Thermally/Electrically Enhance Leadframe Base Package, Amkor Technology.

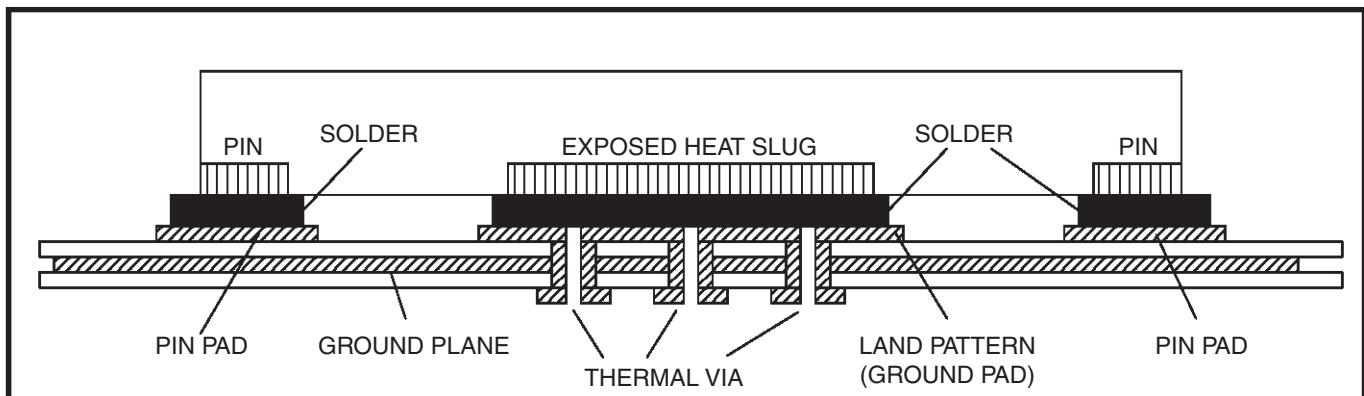

**Figure 3. P.C. Assembly for Exposed Pad Thermal Release Path – Side View (drawing not to scale)**

### Schematic Example

Figure 4 shows a schematic example of the ICS858020. This schematic provides examples of input and output handling. The ICS858020 input has built-in 50Ω termination resistors. The input can directly accept various types of differential signal without AC couple. If AC couple termination is used, the ICS858020 also provides VREF\_AC pin for proper offset level after AC couple. This

example shows the ICS858020 input driven by a 2.5V LVPECL driver with AC couple. The ICS858020 outputs are CML driver with built-in 50Ω pull-up resistors. In this example, we assume the traces are long transmission line and the receiver is high input impedance without built-in matched load. An external 50Ω resistor to V<sub>CC</sub> at the receiver is required for proper termination.

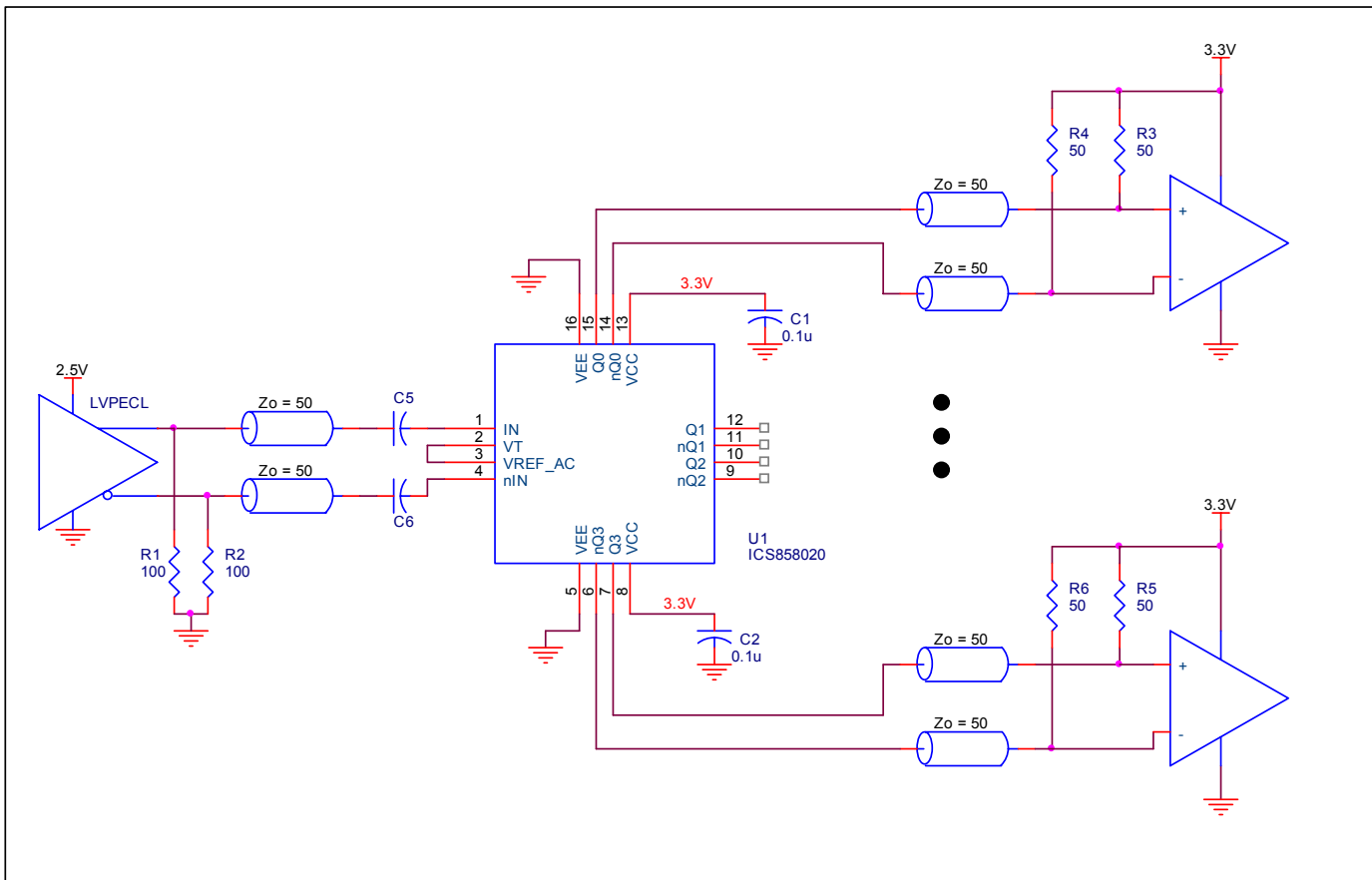

Figure 4. ICS858020 Application Schematic Example

## Reliability Information

Table 4.  $\theta_{JA}$  vs. Air Flow Table for a 16 Lead VFQFN

$\theta_{JA}$ vs. Air Flow			
Linear Feet per Minute	0		
Multi-Layer PCB, JEDEC Standard Test Boards	51.5°C/W		

## Transistor Count

The transistor count for ICS858020 is: 28

Pin compatible with SY58020U

## Package Outline and Package Dimensions

### Package Outline - K Suffix for 16 Lead VFQFN

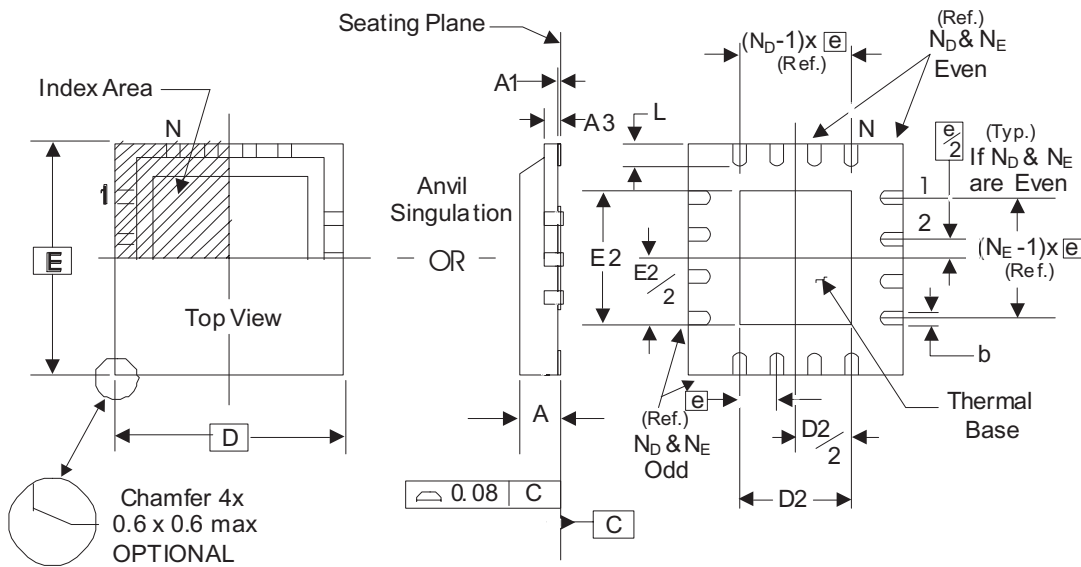

Table 5. K Package Dimensions for 16 Lead VFQFN

All Dimensions in Millimeters		
Symbol	Minimum	Maximum
N	16	
A	0.80	1.0
A1	0	0.05
A3	0.25 Reference	
b	0.18	0.30
e	0.50 Basic	
D, E	3.0	
D2, E2	1.00	1.80
L	0.30	0.50
$N_D N_E$	4.0	

Reference Document: JEDEC Publication 95, MO-220

## Ordering Information

Table 6. Ordering Information

Part/Order Number	Marking	Package	Shipping Packaging	Temperature
858020AK	020A	16 Lead VFQFN	Tube	-40°C to 85°C
858020AKT	020A	16 Lead VFQFN	2500 Tape & Reel	-40°C to 85°C
858020AKLF	20AL	"Lead-Free" 16 Lead VFQFN	Tube	-40°C to 85°C
858020AKLFT	20AL	"Lead-Free" 16 Lead VFQFN	2500 Tape & Reel	-40°C to 85°C

NOTE: Parts that are ordered with an "LF" suffix to the part number are the Pb-Free configuration and are RoHS compliant.

While the information presented herein has been checked for both accuracy and reliability, Integrated Device Technology (IDT) assumes no responsibility for either its use or for the infringement of any patents or other rights of third parties, which would result from its use. No other circuits, patents, or licenses are implied. This product is intended for use in normal commercial and industrial applications. Any other applications, such as those requiring high reliability or other extraordinary environmental requirements are not recommended without additional processing by IDT. IDT reserves the right to change any circuitry or specifications without notice. IDT does not authorize or warrant any IDT product for use in life support devices or critical medical instruments.

## Revision History Sheet

Rev	Table	Page	Description of Change	Date
A	T6	12	Ordering Information Table - correct Shipping Packaging from Tray to Tube.	3/17/06
A	T6	12	Ordering Information Table - corrected marking from 820A to 020A.	4/24/06
A	T6	10 12 13	Added VFQFN EPAD Thermal Release Path section. Updated VFQFN package outline. Ordering Information Table - added Lead-Free marking.	12/10/07
A	T3   T5	3 5 6 10 11	AC Characteristics Table - added conditions to $t_{jit}$ . Parameter Measurement Information, updated <i>Single-ended &amp; Differential Input Voltage Swing</i> diagram. Added <i>Recommendations for Unused Output Pins</i> . Updated schematic example diagram. Package Dimensions Table - corrected D2/E2 dimensions.	09/05/08



ICS858020

LOW SKEW, 1-TO-4, DIFFERENTIAL-TO-CML FANOUT BUFFER

## Contact Information:

**www.IDT.com**

### Sales

800-345-7015 (inside USA)  
+408-284-8200 (outside USA)  
Fax: 408-284-2775  
[www.IDT.com/go/contactIDT](http://www.IDT.com/go/contactIDT)

### Technical Support

[netcom@idt.com](mailto:netcom@idt.com)  
+480-763-2056

### Corporate Headquarters

Integrated Device Technology, Inc.  
6024 Silver Creek Valley Road  
San Jose, CA 95138  
United States  
800-345-7015 (inside USA)  
+408-284-8200 (outside USA)

