



Chipsmall Limited consists of a professional team with an average of over 10 year of expertise in the distribution of electronic components. Based in Hongkong, we have already established firm and mutual-benefit business relationships with customers from,Europe,America and south Asia,supplying obsolete and hard-to-find components to meet their specific needs.

With the principle of “Quality Parts,Customers Priority,Honest Operation,and Considerate Service”,our business mainly focus on the distribution of electronic components. Line cards we deal with include Microchip,ALPS,ROHM,Xilinx,Pulse,ON,Everlight and Freescale. Main products comprise IC,Modules,Potentiometer,IC Socket,Relay,Connector.Our parts cover such applications as commercial,industrial, and automotives areas.

We are looking forward to setting up business relationship with you and hope to provide you with the best service and solution. Let us make a better world for our industry!



## Contact us

Tel: +86-755-8981 8866 Fax: +86-755-8427 6832

Email & Skype: info@chipsmall.com Web: www.chipsmall.com

Address: A1208, Overseas Decoration Building, #122 Zhenhua RD., Futian, Shenzhen, China





# LOW SKEW, 1-TO-4 DIFFERENTIAL-TO-LVDS FANOUT BUFFER W/INTERNAL TERMINATION

# ICS889833

## GENERAL DESCRIPTION



The ICS889833 is a high speed 1-to-4 Differential-to-LVDS Fanout Buffer w/Internal Termination and is a member of the HiPerClockS™ family of high performance clock solutions from IDT. The ICS889833 is optimized for high speed and very low output skew, making it suitable for use in demanding applications such as SONET, 1 Gigabit and 10 Gigabit Ethernet, and Fibre Channel. The internally terminated differential input and VREF\_AC pin allow other differential signal families such as LVPECL, LVDS, and CML to be easily interfaced to the input with minimal use of external components. The device also has an output enable pin which may be useful for system test and debug purposes. The ICS889833 is packaged in a small 3mm x 3mm 16-pin VFQFN package which makes it ideal for use in space-constrained applications.

## FEATURES

- Four differential LVDS outputs
- IN, nIN input pair can accept the following differential input levels: LVPECL, LVDS, CML
- Output frequency: >2GHz
- Cycle-to-cycle jitter, RMS: 0.2ps (maximum)
- Additive phase jitter, RMS: 0.04ps (typical)
- Total jitter: 10ps (maximum)
- Output skew: 40ps (maximum)
- Part-to-part skew: 200ps (maximum)
- Propagation delay: 520ps (maximum)
- 3.3V operating supply
- -40°C to 85°C ambient operating temperature
- Available in both standard (RoHS 5) and lead-free (RoHS 6) packages

## BLOCK DIAGRAM

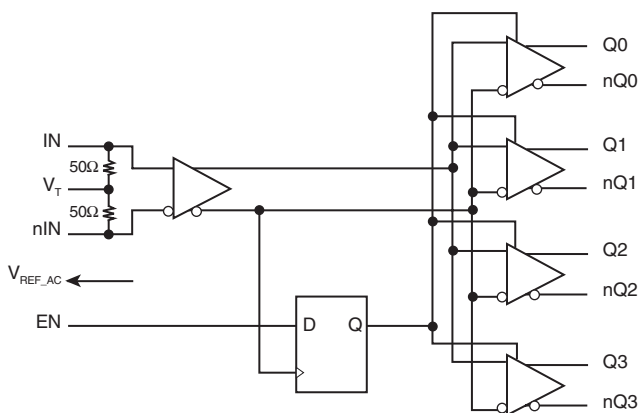

## PIN ASSIGNMENT

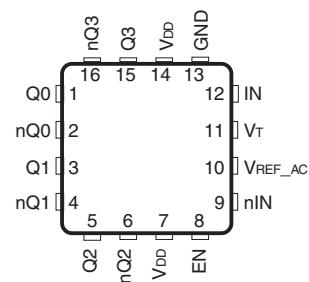

**ICS889833**  
**16-Lead VFQFN**  
 3mm x 3mm x 0.925mm package body  
**K Package**  
 Top View

**TABLE 1. PIN DESCRIPTIONS**

Number	Name	Type		Description
1, 2	Q0, nQ0	Output		Differential output pair. Normally terminated with 100Ω across the pair. Unused outputs must be terminated with 100Ω across the pin (Q0/nQ0). LVDS interface levels.
3, 4	Q1, nQ1	Output		Differential output pair. Normally terminated with 100Ω across the pair. Unused outputs must be terminated with 100Ω across the pin (Q1/nQ1). LVDS interface levels.
5, 6	Q2, nQ2	Output		Differential output pair. Normally terminated with 100Ω across the pair. Unused outputs must be terminated with 100Ω across the pin (Q2/nQ2). LVDS interface levels.
7, 14	V <sub>DD</sub>	Power		Positive supply pins.
8	EN	Input	Pullup	Synchronizing output enable pin. When LOW, enables/disables outputs. When HIGH, enables outputs when left open. Internally connected to a 37kΩ pull-up resistor. LVTTTL / LVCMOS interface levels.
9	nIN	Input		Inverting differential clock input. R <sub>T</sub> = 50Ω termination to V <sub>T</sub> .
10	V <sub>REF_AC</sub>	Output		Reference voltage for AC-coupled applications. Equal to V <sub>DD</sub> - 1.4V (approx.). Maximum sink/source current is 0.5mA.
11	V <sub>T</sub>	Input		Input termination center-tap. Each side of the differential input pair terminates to a V <sub>T</sub> pin. The V <sub>T</sub> pins provide a center-tap to a termination network for maximum interface flexibility.
12	IN	Input		Non-inverting differential clock input. R <sub>T</sub> = 50Ω termination to V <sub>T</sub> .
13	GND	Power		Power supply ground.
15, 16	Q3, nQ3	Output		Differential output pair. Normally terminated with 100Ω across the pair. Unused outputs must be terminated with 100Ω across the pin (Q3nQ3). LVDS interface levels.

NOTE: *Pullup* refers to internal input resistors. See Table 2, Pin Characteristics, for typical values.

**TABLE 2. PIN CHARACTERISTICS**

Symbol	Parameter	Test Conditions	Minimum	Typical	Maximum	Units
R <sub>PULLUP</sub>	Input Pullup Resistor			37		kΩ

**TABLE 3. CONTROL INPUT FUNCTION TABLE**

Inputs			Outputs	
IN	nIN	EN	Q0:Q3	nQ0:nQ3
0	1	1	0	1
1	0	1	1	0
X	X	0	0 (NOTE 1)	1 (NOTE 1)

NOTE 1: On the next negative transition of the input signal (IN).

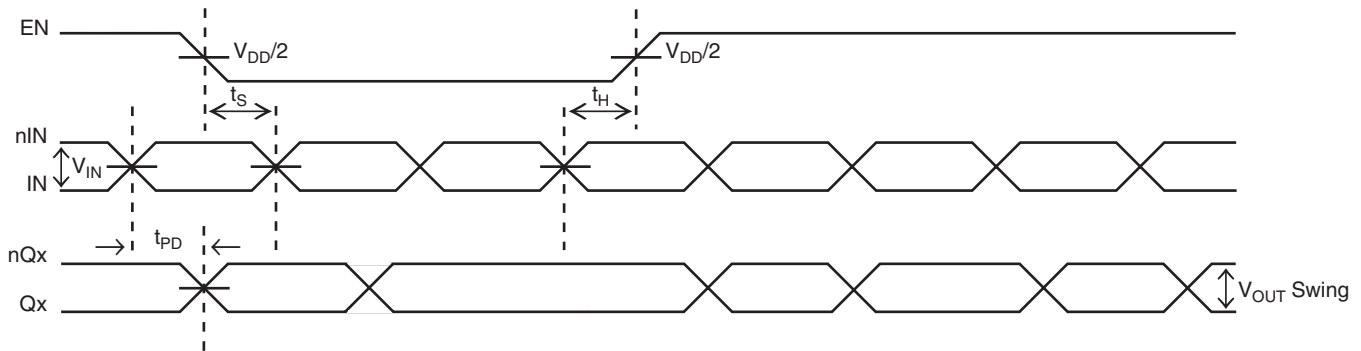

**FIGURE 1. EN TIMING DIAGRAM**

## ABSOLUTE MAXIMUM RATINGS

Supply Voltage, $V_{DD}$	4.6V
Inputs, $V_I$	-0.5V to $V_{DD} + 0.5 V$
Outputs, $I_O$ (LVDS)	
Continuous Current	10mA
Surge Current	15mA
Input Current, $I_N$ , nIN	$\pm 50$ mA
$V_T$ Current, $I_{VT}$	$\pm 100$ mA
Input Sink/Source, $I_{REF\_AC}$	$\pm 0.5$ mA
Operating Temperature Range, $T_A$	-40°C to +85°C
Storage Temperature, $T_{STG}$	-65°C to 150°C
Package Thermal Impedance, $\theta_{JA}$ (Junction-to-Ambient)	90.2°C/W (0 lfpm)

NOTE: Stresses beyond those listed under Absolute Maximum Ratings may cause permanent damage to the device. These ratings are stress specifications only. Functional operation of product at these conditions or any conditions beyond those listed in the *DC Characteristics* or *AC Characteristics* is not implied. Exposure to absolute maximum rating conditions for extended periods may affect product reliability.

**TABLE 4A. POWER SUPPLY DC CHARACTERISTICS,  $V_{DD} = 3.3V \pm 0.3V$ ;  $T_A = -40^\circ C$  TO  $85^\circ C$**

Symbol	Parameter	Test Conditions	Minimum	Typical	Maximum	Units
$V_{DD}$	Positive Supply Voltage		3.0	3.3	3.6	V
$I_{DD}$	Power Supply Current				100	mA

**TABLE 4B. LVCMOS/LVTTL DC CHARACTERISTICS,  $V_{DD} = 3.3V \pm 0.3V$ ;  $T_A = -40^\circ C$  TO  $85^\circ C$**

Symbol	Parameter	Test Conditions	Minimum	Typical	Maximum	Units
$V_{IH}$	Input High Voltage		2		$V_{DD} + 0.3$	V
$V_{IL}$	Input Low Voltage		-0.3		0.8	V
$I_{IH}$	Input High Current	$V_{DD} = V_{IN} = 3.6V$	-125		30	$\mu A$
$I_{IL}$	Input Low Current	$V_{DD} = 3.6V, V_{IN} = 0V$			-300	$\mu A$

NOTE: Specs are design targets unless otherwise noted.

**TABLE 4C. DC CHARACTERISTICS,  $V_{DD} = 3.3V \pm 0.3V$ ;  $T_A = -40^\circ C$  TO  $85^\circ C$**

Symbol	Parameter	Test Conditions	Minimum	Typical	Maximum	Units
$R_{DIFF\_IN}$	Differential Input Resistance	(IN, nIN)	80	100	120	$\Omega$
$R_{IN}$	Input Resistance	IN-to-VT	40	50	60	$\Omega$
$V_{IH}$	Input High Voltage	(IN, nIN)	1.2		$V_{DD}$	V
$V_{IL}$	Input Low Voltage	(IN, nIN)	0		$V_{DD} - 0.15$	V
$V_{IN}$	Input Voltage Swing		0.15		1.7	V
$V_{DIFF\_IN}$	Differential Input Voltage Swing		0.3			V
$V_{REF\_AC}$	Bias Voltage		$V_{DD} - 1.45$	$V_{DD} - 1.35$	$V_{DD} - 1.25$	V

**TABLE 4C. LVDS DC CHARACTERISTICS,  $V_{DD} = 3.3V \pm 0.3V$ ;  $T_A = -40^\circ C$  TO  $85^\circ C$**

Symbol	Parameter	Test Conditions	Minimum	Typical	Maximum	Units
$V_{OD}$	Differential Output Voltage		250	325		mV
$\Delta V_{OD}$	$V_{OD}$ Magnitude Change		500	650		V
$V_{OS}$	Offset Voltage		1.15	1.35	1.55	V
$\Delta V_{OS}$	$V_{OS}$ Magnitude Change				50	mV

**TABLE 5. AC CHARACTERISTICS,  $V_{DD} = 3.3V \pm 0.3V$ ;  $T_A = -40^\circ C$  TO  $85^\circ C$**

Symbol	Parameter	Condition	Minimum	Typical	Maximum	Units
$f_{MAX}$	Maximum Output Frequency		2.0			GHz
$t_{PD}$	Propagation Delay, (Differential); NOTE 1	IN to Qx	300		520	ps
$tsk(o)$	Output Skew; NOTE 2, 3				40	ps
$tsk(pp)$	Part-to-Part Skew; NOTE 3, 4				200	ps
$tjit (cc)$	Cycle-to-Cycle Jitter, RMS; NOTE 5				0.2	ps
$tjit$	Buffer Additive Phase Jitter, RMS; refer to Additive Phase Jitter section	$f = 622.08MHz$ , Integration Range: 12kHz - 20MHz		0.04		ps
		$f \geq 156.25MHz$ , Integration Range: 12kHz - 20MHz			0.225	ps
$tjit (j)$	Total Jitter; NOTE 5				10	ps
$tjit (rj)$	Random Jitter; NOTE 5				1	ps
$tjit (tj)$	Deterministic Jitter; NOTE 5				2	ps
$t_s$	Setup Time	EN to IN/nIN	300			ps
$t_H$	Hold Time	EN to IN/nIN	500			ps
$t_R/t_F$	Output Rise/Fall Time; NOTE 5	20% - 80%	100		220	ps

All parameters characterized at  $\leq 1.4GHz$  unless otherwise noted.

NOTE 1: Measured from the differential input crossing point to the differential output crossing point.

NOTE 2: Defined as skew between outputs at the same supply voltage and with equal load conditions.

Measured at the output differential cross points.

NOTE 3: This parameter is defined in accordance with JEDEC Standard 65.

NOTE 4: Defined as skew between outputs on different devices operating at the same supply voltage and with equal load conditions. Using the same type of inputs on each device, the outputs are measured at the differential cross points.

NOTE 5: Tested at  $f \leq 750MHz$ .

## ADDITIVE PHASE JITTER

The spectral purity in a band at a specific offset from the fundamental compared to the power of the fundamental is called the ***dBc Phase Noise***. This value is normally expressed using a Phase noise plot and is most often the specified plot in many applications. Phase noise is defined as the ratio of the noise power present in a 1Hz band at a specified offset from the fundamental frequency to the power value of the fundamental. This ratio is expressed in decibels (dBm) or a ratio of the power in the 1Hz

band to the power in the fundamental. When the required offset is specified, the phase noise is called a ***dBc*** value, which simply means dBm at a specified offset from the fundamental. By investigating jitter in the frequency domain, we get a better understanding of its effects on the desired application over the entire time record of the signal. It is mathematically possible to calculate an expected bit error rate given a phase noise plot.

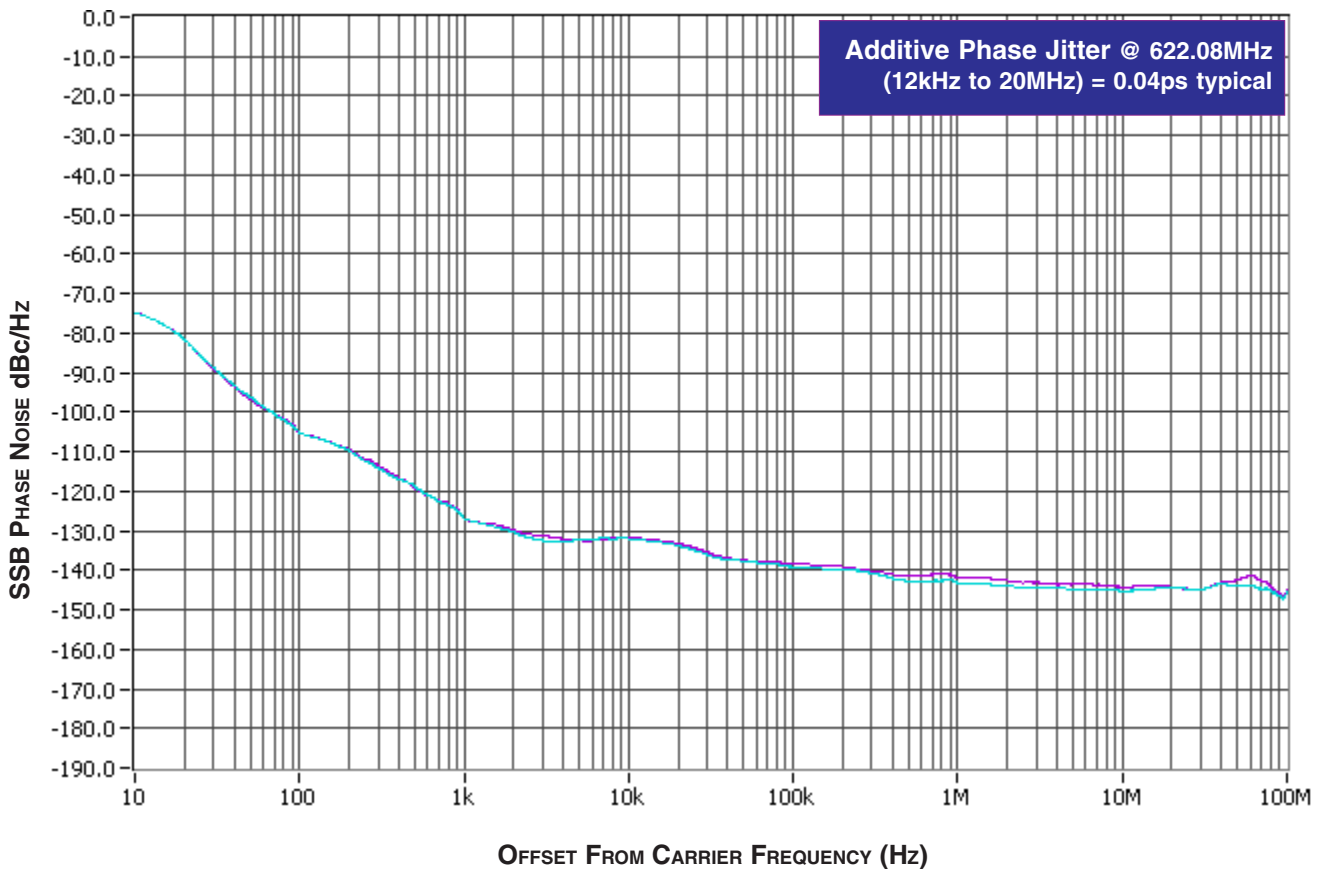

As with most timing specifications, phase noise measurements have issues. The primary issue relates to the limitations of the equipment. Often the noise floor of the equipment is higher than the noise floor of the device. This is illustrated above. The device

meets the noise floor of what is shown, but can actually be lower. The phase noise is dependant on the input source and measurement equipment.

# PARAMETER MEASUREMENT INFORMATION

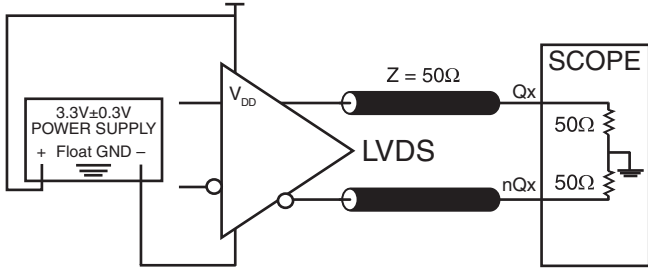

**OUTPUT LOAD AC TEST CIRCUIT**

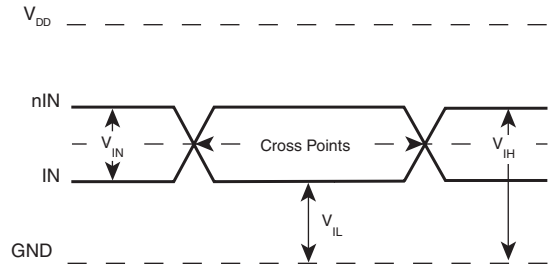

**DIFFERENTIAL INPUT LEVEL**

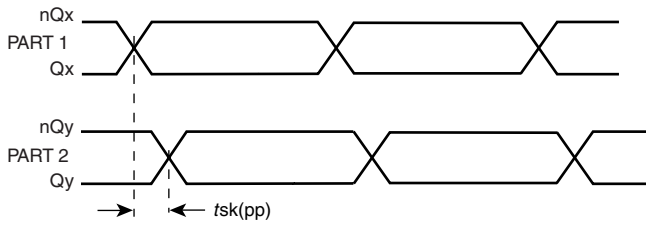

**PART-TO-PART SKEW**

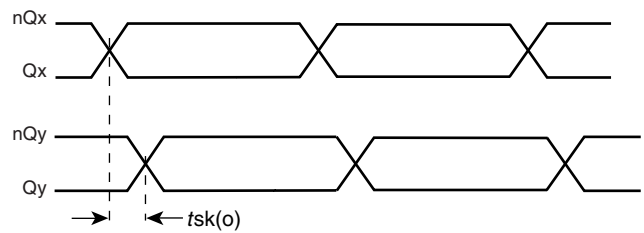

**OUTPUT SKEW**

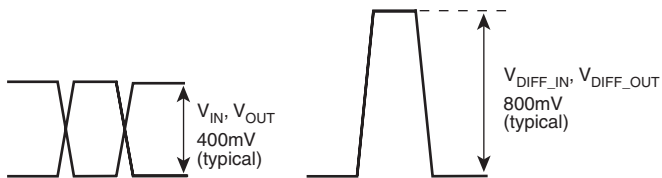

**SINGLE ENDED & DIFFERENTIAL INPUT VOLTAGE SWING**

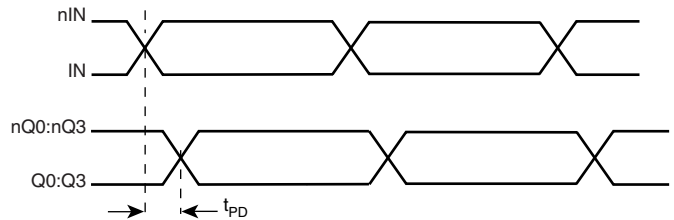

**PROPAGATION DELAY**



# PARAMETER MEASUREMENT INFORMATION, CONTINUED

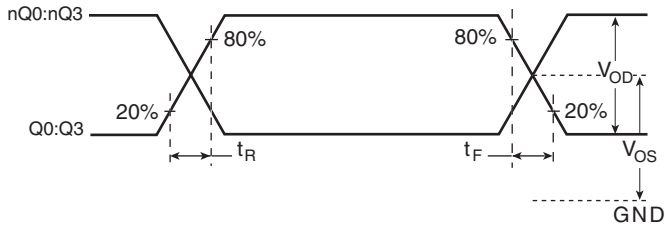

OUTPUT RISE/FALL TIME

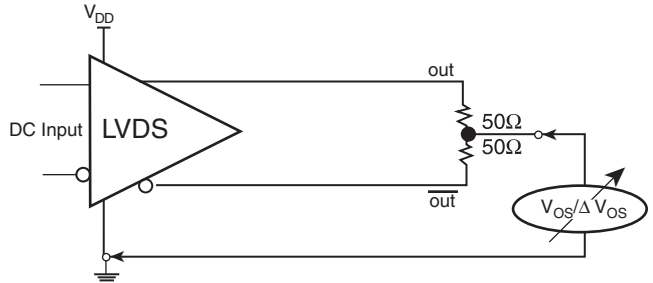

OFFSET VOLTAGE SETUP

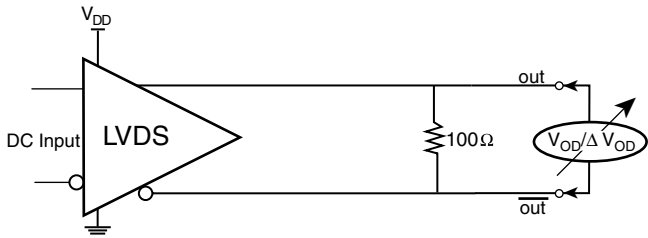

DIFFERENTIAL OUTPUT VOLTAGE SETUP

## Setting for Output Phase Jitter Measurement

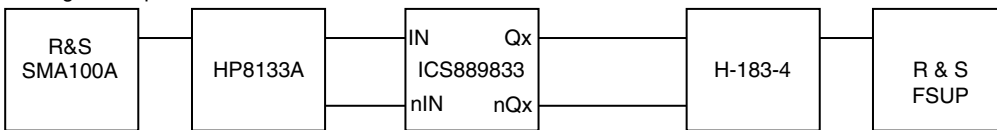

## Setting for Input Phase Jitter Measurement

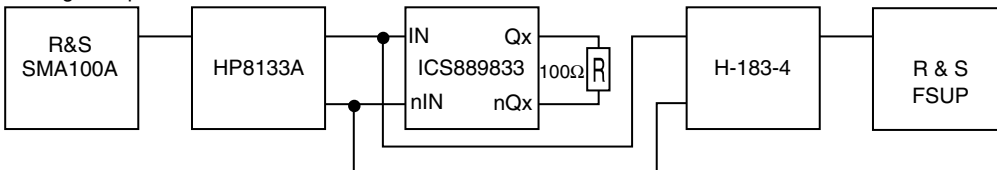

$$t_{jit} = \sqrt{t_{jit}^2(\emptyset) \text{ (output)} - t_{jit}^2(\emptyset) \text{ (input)}}$$

Where  $t_{jit}(\emptyset)$  is RMS Phase Jitter

## BUFFER ADDITIVE PHASE JITTER TEST CIRCUIT

# APPLICATION INFORMATION

## LVPECL INPUT WITH BUILT-IN 50Ω TERMINATIONS INTERFACE

The IN/nIN with built-in 50Ω terminations accepts LVDS, LVPECL, CML and other differential signals. The signal must meet the  $V_{IN}$  and  $V_{IH}$  input requirements. Figures 2A to 2F show interface examples for the HiPerClockS IN/nIN input with built-in 50Ω terminations driven by the most common driver types. The input

interfaces suggested here are examples only. If the driver is from another vendor, use their termination recommendation. Please consult with the vendor of the driver component to confirm the driver termination requirements.

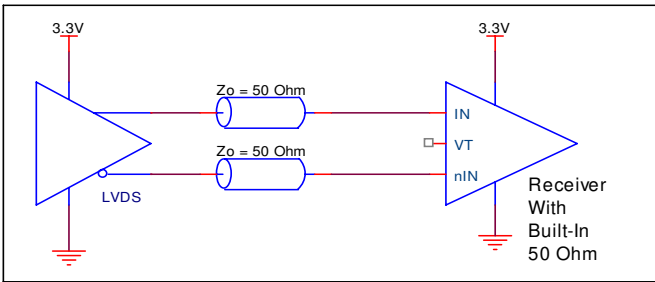

**FIGURE 2A. HiPerClockS IN/nIN INPUT WITH BUILT-IN 50Ω DRIVEN BY AN LVDS DRIVER**

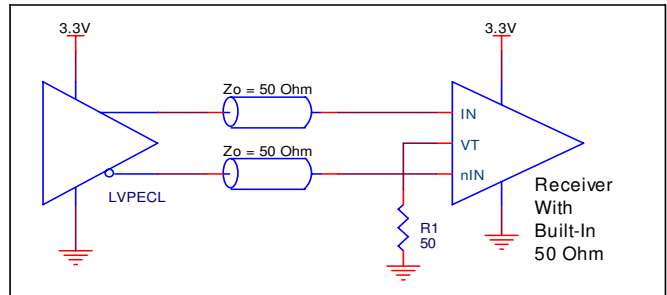

**FIGURE 2B. HiPerClockS IN/nIN INPUT WITH BUILT-IN 50Ω DRIVEN BY AN LVPECL DRIVER**

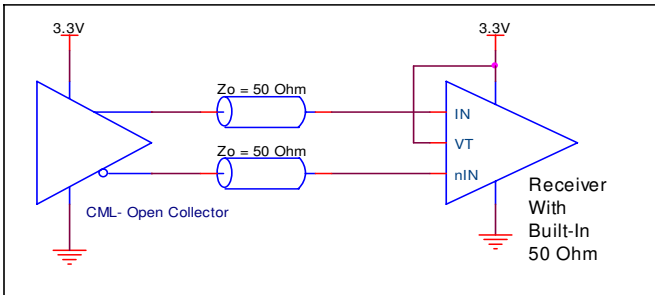

**FIGURE 2C. HiPerClockS IN/nIN INPUT WITH BUILT-IN 50Ω DRIVEN BY A CML DRIVER WITH OPEN COLLECTOR**

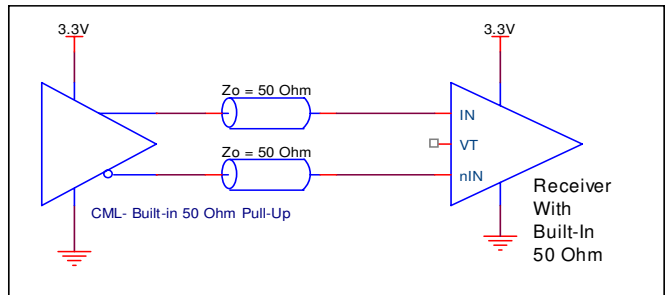

**FIGURE 2D. HiPerClockS IN/nIN INPUT WITH BUILT-IN 50Ω DRIVEN BY A CML DRIVER WITH BUILT-IN 50Ω PULLUP**

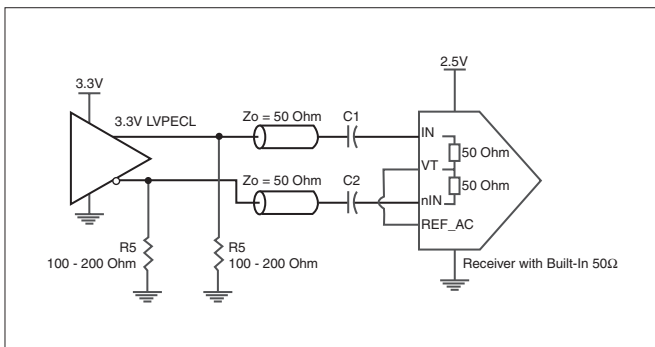

**FIGURE 2E. HiPerClockS IN/nIN INPUT WITH BUILT-IN 50Ω DRIVEN BY A 3.3V LVPECL DRIVER**

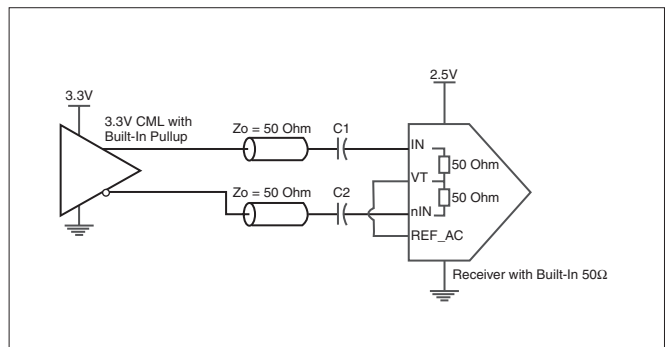

**FIGURE 2F. HiPerClockS IN/nIN INPUT WITH BUILT-IN 50Ω DRIVEN BY A 3.3V CML DRIVER WITH BUILT-IN PULLUP**

## RECOMMENDATIONS FOR UNUSED INPUT AND OUTPUT PINS

### INPUTS:

#### LVC MOS SELECT PINS

All control pins have internal pull-ups or pull-downs; additional resistance is not required but can be added for additional protection. A 1k $\Omega$  resistor can be used.

### OUTPUTS:

#### LVDS OUTPUTS

All unused LVDS output pairs must be terminated with 100 $\Omega$  across.

---

---

### 3.3V LVDS DRIVER TERMINATION

A general LVDS interface is shown in *Figure 3*. In a 100 $\Omega$  differential transmission line environment, LVDS drivers require a matched load termination of 100 $\Omega$  across near the receiver

input. For a multiple LVDS outputs buffer, if only partial outputs are used, it is recommended to terminate the unused outputs.

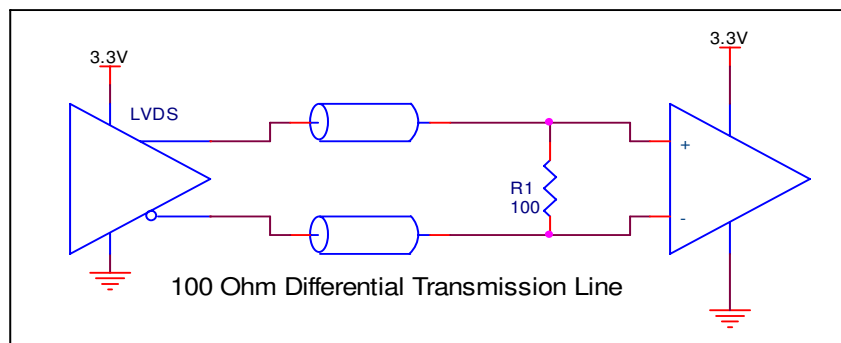

FIGURE 3. TYPICAL LVDS DRIVER TERMINATION

## VFQFN EPAD THERMAL RELEASE PATH

In order to maximize both the removal of heat from the package and the electrical performance, a land pattern must be incorporated on the Printed Circuit Board (PCB) within the footprint of the package corresponding to the exposed metal pad or exposed heat slug on the package, as shown in *Figure 4*. The solderable area on the PCB, as defined by the solder mask, should be at least the same size/shape as the exposed pad/slug area on the package to maximize the thermal/electrical performance. Sufficient clearance should be designed on the PCB between the outer edges of the land pattern and the inner edges of pad pattern for the leads to avoid any shorts.

While the land pattern on the PCB provides a means of heat transfer and electrical grounding from the package to the board through a solder joint, thermal vias are necessary to effectively conduct from the surface of the PCB to the ground plane(s). The land pattern must be connected to ground through these vias. The vias act as “heat pipes”. The number of vias (i.e. “heat pipes”)

are application specific and dependent upon the package power dissipation as well as electrical conductivity requirements. Thus, thermal and electrical analysis and/or testing are recommended to determine the minimum number needed. Maximum thermal and electrical performance is achieved when an array of vias is incorporated in the land pattern. It is recommended to use as many vias connected to ground as possible. It is also recommended that the via diameter should be 12 to 13mils (0.30 to 0.33mm) with 1oz copper via barrel plating. This is desirable to avoid any solder wicking inside the via during the soldering process which may result in voids in solder between the exposed pad/slug and the thermal land. Precautions should be taken to eliminate any solder voids between the exposed heat slug and the land pattern. Note: These recommendations are to be used as a guideline only. For further information, refer to the Application Note on the *Surface Mount Assembly* of Amkor’s Thermally/Electrically Enhance Leadframe Base Package, Amkor Technology.

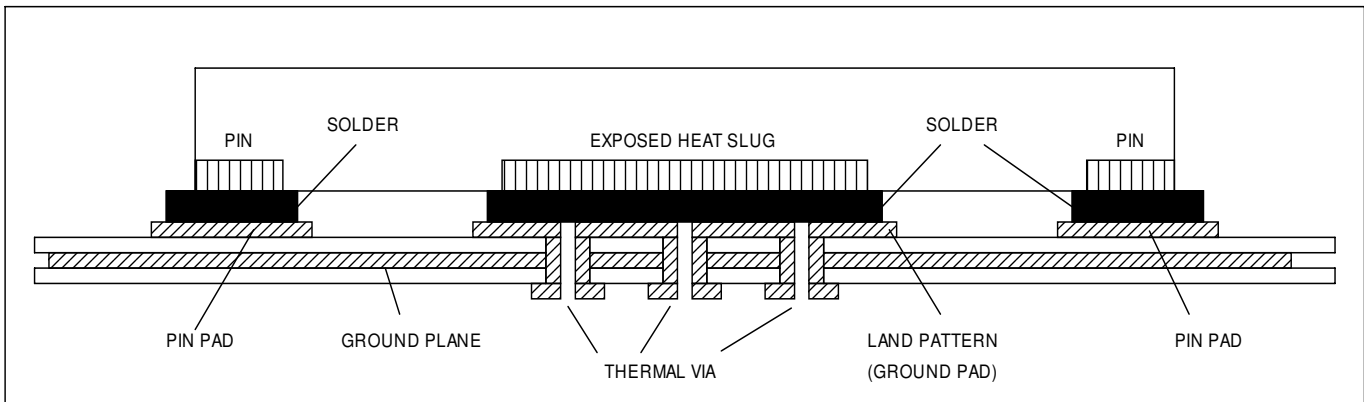

**FIGURE 4. P.C.ASSEMBLY FOR EXPOSED PAD THERMAL RELEASE PATH –SIDE VIEW (DRAWING NOT TO SCALE)**

# POWER CONSIDERATIONS

This section provides information on power dissipation and junction temperature for the ICS889833. Equations and example calculations are also provided.

## 1. Power Dissipation.

The total power dissipation for the ICS889833 is the sum of the core power plus the power dissipated in the load(s). The following is the power dissipation for  $V_{DD} = 3.3V + 0.3V = 3.6V$ , which gives worst case results.

- $Power_{-MAX} = V_{DD\_MAX} * I_{DD\_MAX} = 3.6V * 100mA = \mathbf{360mW}$

## 2. Junction Temperature.

Junction temperature,  $T_j$ , is the temperature at the junction of the bond wire and bond pad and directly affects the reliability of the device. The maximum recommended junction temperature for HiPerClockS™ devices is 125°C.

The equation for  $T_j$  is as follows:  $T_j = \theta_{JA} * Pd\_total + T_A$

$T_j$  = Junction Temperature

$\theta_{JA}$  = Junction-to-Ambient Thermal Resistance

$Pd\_total$  = Total Device Power Dissipation (example calculation is in section 1 above)

$T_A$  = Ambient Temperature

In order to calculate junction temperature, the appropriate junction-to-ambient thermal resistance  $\theta_{JA}$  must be used. Assuming air flow of 200 linear feet per minute and a multi-layer board, the appropriate value is 78.8°C/W per Table 6 below.

Therefore,  $T_j$  for an ambient temperature of 85°C with all outputs switching is:  
 $85^\circ C + 0.360W * 78.8^\circ C/W = 113.4^\circ C$ . This is below the limit of 125°C.

This calculation is only an example.  $T_j$  will obviously vary depending on the number of loaded outputs, supply voltage, air flow, and the type of board (single layer or multi-layer).

**TABLE 6. THERMAL RESISTANCE  $\theta_{JA}$  FOR 16-PIN VFQFN, FORCED CONVECTION**

$\theta_{JA}$ vs. 0 Air Flow (Linear Feet per Minute)			
	0	200	500
Multi-Layer PCB, JEDEC Standard Test Boards	90.2°C/W	78.8°C/W	70.7°C/W

# RELIABILITY INFORMATION

TABLE 7.  $\theta_{JA}$  vs. AIR FLOW TABLE FOR 16 LEAD VFQFN

$\theta_{JA}$ vs. 0 Air Flow (Linear Feet per Minute)			
	0	200	500
Multi-Layer PCB, JEDEC Standard Test Boards	90.2°C/W	78.8°C/W	70.7°C/W

## TRANSISTOR COUNT

The transistor count for ICS889833 is: 181

Pin compatible with SY89833L

**PACKAGE OUTLINE - K SUFFIX FOR 16 LEAD VFQFN**

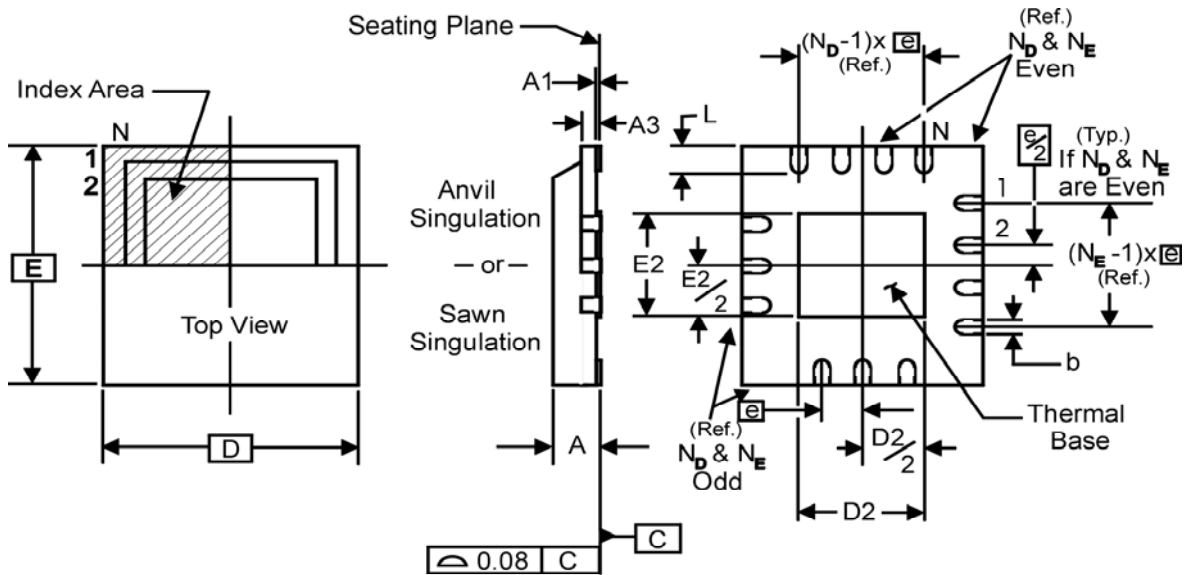

NOTE: The following package mechanical drawing is a generic drawing that applies to any pin count VFQFN package. This drawing is not intended to convey the actual pin count or pin layout of

this device. The pin count and pinout are shown on the front page. The package dimensions are in Table 8 below.

**TABLE 8. PACKAGE DIMENSIONS**

JEDEC VARIATION ALL DIMENSIONS IN MILLIMETERS		
SYMBOL	MINIMUM	MAXIMUM
N	16	
A	0.80	1.0
A1	0	0.05
A3	0.25 Reference	
b	0.18	0.30
e	0.50 BASIC	
$N_D$	4	
$N_E$	4	
D	3.0	
D2	1.0	1.8
E	3.0	
E2	1.0	1.8
L	0.30	0.50

Reference Document: JEDEC Publication 95, MO-220

**TABLE 9. ORDERING INFORMATION**

Part/Order Number	Marking	Package	Shipping Packaging	Temperature
889833AK	833A	16 Lead VFQFN	tube	-40°C to 85°C
889833AKT	833A	16 Lead VFQFN	2500 tape & reel	-40°C to 85°C
889833AKLF	33AL	16 Lead "Lead-Free" VFQFN	tube	-40°C to 85°C
889833AKLFT	33AL	16 Lead "Lead-Free" VFQFN	2500 tape & reel	-40°C to 85°C

NOTE: Parts that are ordered with an "LF" suffix to the part number are the Pb-Free configuration and are RoHS compliant.

While the information presented herein has been checked for both accuracy and reliability, Integrated Device Technology, Incorporated (IDT) assumes no responsibility for either its use or for infringement of any patents or other rights of third parties, which would result from its use. No other circuits, patents, or licenses are implied. This product is intended for use in normal commercial and industrial applications. Any other applications such as those requiring high reliability or other extraordinary environmental requirements are not recommended without additional processing by IDT. IDT reserves the right to change any circuitry or specifications without notice. IDT does not authorize or warrant any IDT product for use in life support devices or critical medical instruments.



**REVISION HISTORY SHEET**

<b>Rev</b>	<b>Table</b>	<b>Page</b>	<b>Description of Change</b>	<b>Date</b>
B	T2	2	Pin Description Table - corrected pin number for Q3/nQ3. Corrected pin description for IN/nIN.	9/9/08
	T5	5	AC Characteristics Table - added 156.25MHz Additive Phase Jitter spec.	
		8	Parameter Measurement Information - added <i>Buffer Additive Phase Jitter Test Circuit Diagram</i> .	
		11	Updated Thermal Release Path section.	

**Innovate with IDT and accelerate your future networks. Contact:**  
**www.IDT.com**

**For Sales**

800-345-7015 (inside USA)  
+408-284-8200 (outside USA)  
Fax: 408-284-2775  
[www.IDT.com/go/contactIDT](http://www.IDT.com/go/contactIDT)

**For Tech Support**

[netcom@idt.com](mailto:netcom@idt.com)  
+480-763-2056

**Corporate Headquarters**

Integrated Device Technology, Inc.  
6024 Silver Creek Valley Road  
San Jose, CA 95138  
United States  
800-345-7015 (inside USA)  
+408-284-8200 (outside USA)

