



Chipsmall Limited consists of a professional team with an average of over 10 year of expertise in the distribution of electronic components. Based in Hongkong, we have already established firm and mutual-benefit business relationships with customers from,Europe,America and south Asia,supplying obsolete and hard-to-find components to meet their specific needs.

With the principle of “Quality Parts,Customers Priority,Honest Operation,and Considerate Service”,our business mainly focus on the distribution of electronic components. Line cards we deal with include Microchip,ALPS,ROHM,Xilinx,Pulse,ON,Everlight and Freescale. Main products comprise IC,Modules,Potentiometer,IC Socket,Relay,Connector.Our parts cover such applications as commercial,industrial, and automotives areas.

We are looking forward to setting up business relationship with you and hope to provide you with the best service and solution. Let us make a better world for our industry!



Contact us

Tel: +86-755-8981 8866 Fax: +86-755-8427 6832

Email & Skype: info@chipsmall.com Web: www.chipsmall.com

Address: A1208, Overseas Decoration Building, #122 Zhenhua RD., Futian, Shenzhen, China





General Purpose Frequency Timing Generator

Recommended Application:

General Purpose Clock Generator

Output Features:

- 17 - PCI clocks selectable, either 33.33MHz or 66.6MHz @ 3.3V
- 1 - 48MHz @ 3.3V
- 1 - REF @ 3.3V, 14.318MHz.

Features:

- Programmable Spread spectrum percentage for EMI control
- Uses external 14.318MHz crystal
- Select pins for frequency select

Key Specifications:

- PCI – PCI output skew within same bank @ 33MHz: <170ps
- PCI – PCI output skew within same bank @ 66MHz: <340ps
- Cycle to Cycle Jitter PCI @ 33MHz: <200ps
- Cycle to Cycle Jitter PCI @ 66MHz: <200ps
- Cycle to Cycle Jitter 48MHz: <350ps
- Cycle to Cycle Jitter REF: <500ps
- Slew Rate: 1.5 - 4 V/ns. (PCI spec.)

Pin Configuration

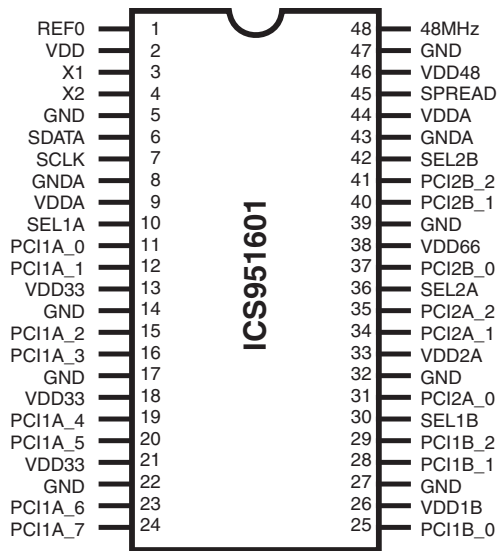

48-pin SSOP

*120K ohm pull-up to VDD on indicated inputs.

Block Diagram

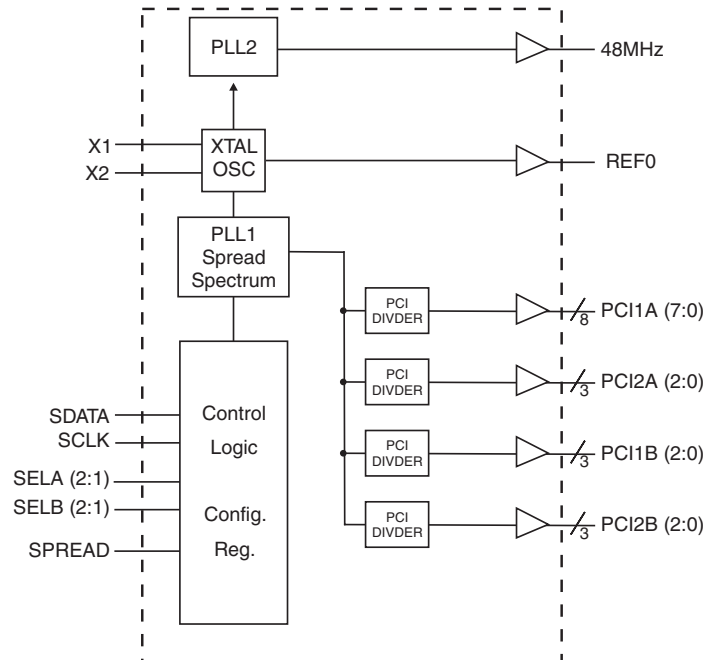

Power Groups:

VDDA = Analog Power
GNDA = Analog Ground

ICS951601

Preliminary Product Preview



Pin Descriptions

Pin number	Pin name	Type	Description
1	REF0	OUT	Reference output
2, 13, 18, 21, 26, 33, 38, 46	VDD	PWR	3.3V Power supply
3	X1	IN	Crystal input, nominally 14.318MHz.
4	X2	OUT	Crystal output, nominally 14.318MHz.
9, 44	VDDA	PWR	Analog 3.3V Power supply
10, 30, 36, 42	SELxx	IN	Real time PCI output frequency selection pins
5, 14, 17, 22, 27, 32, 39, 47	GND	PWR	Ground pins
6	SDATA	I/O	Data pin for I ² C circuitry 5V tolerant
7	SCLK	IN	Clock input of I ² C input
8, 43	GNDA	PWR	Analog ground pins
24, 23, 20, 19, 16, 15, 12, 11,	PCI1A (7:0)	OUT	PCI clock outputs, selectable to be either 33.33 or 66.66MHz at 3.3V.
29, 28, 25	PCI1B (2:0)	OUT	PCI clock outputs, selectable to be either 33.33 or 66.66MHz at 3.3V.
35, 34, 31	PCI2A (2:0)	OUT	PCI clock outputs, selectable to be either 33.33 or 66.66MHz at 3.3V.
41, 40, 37	PCI2B (2:0)	OUT	PCI clock outputs, selectable to be either 33.33 or 66.66MHz at 3.3V.
45	SPREAD	IN	Enables Spread Spectrum, default is on.
48	48MHz	OUT	Fixed 48MHz clock output for USB.



General I²C serial interface information

The information in this section assumes familiarity with I²C programming.

How to Write:

- Controller (host) sends a start bit.
- Controller (host) sends the write address D2_(H)
- ICS clock will **acknowledge**
- Controller (host) sends a dummy command code
- ICS clock will **acknowledge**
- Controller (host) sends a dummy byte count
- ICS clock will **acknowledge**
- Controller (host) starts sending first byte (Byte 0) through byte 5
- ICS clock will **acknowledge** each byte **one at a time**.

How to Write:	
Controller (Host)	ICS (Slave/Receiver)
Start Bit	
Address D2 _(H)	
	ACK
Dummy Command Code	
	ACK
Dummy Byte Count	
	ACK
Byte 0	
	ACK
Byte 1	
	ACK
Byte 2	
	ACK
Byte 3	
	ACK
Byte 4	
	ACK
Byte 5	
	ACK
Stop Bit	

How to Read:

- Controller (host) will send start bit.
- Controller (host) sends the read address D3_(H)
- ICS clock will **acknowledge**
- ICS clock will send the **byte count**
- Controller (host) acknowledges
- ICS clock sends first byte (**Byte 0**) through **byte 5**
- Controller (host) will need to acknowledge each byte

How to Read:	
Controller (Host)	ICS (Slave/Receiver)
Start Bit	
Address D3 _(H)	
	ACK
	Byte Count
ACK	
	Byte 0
ACK	
	Byte 1
ACK	
	Byte 2
ACK	
	Byte 3
ACK	
	Byte 4
ACK	
	Byte 5
ACK	
Stop Bit	

Notes:

1. The ICS clock generator is a slave/receiver, I²C component. It can read back the data stored in the latches for verification. **Read-Back will support Intel PIIX4 "Block-Read" protocol.**
2. The data transfer rate supported by this clock generator is 100K bits/sec or less (standard mode)
3. The input is operating at 3.3V logic levels.
4. The data byte format is 8 bit bytes.
5. To simplify the clock generator I²C interface, the protocol is set to use only "**Block-Writes**" from the controller. The bytes must be accessed in sequential order from lowest to highest byte with the ability to stop after any complete byte has been transferred. The Command code and Byte count shown above must be sent, but the data is ignored for those two bytes. The data is loaded until a Stop sequence is issued.
6. At power-on, all registers are set to a default condition, as shown.

ICS951601

Preliminary Product Preview



Serial Configuration Command Bitmap

Byte 0: Functionality and frequency select register (Default = 0)

Bit	Bit2	Bit7	Bit6	Bit5	Bit4	66MHZ	33MHZ	FEATURES	PWD
	FS4	FS3	FS2	FS1	FS0				
Bit 2,7:4	0	0	0	0	0	66	33	-0.25 % down spread	00000
	0	0	0	0	1	66	33	-0.5 % down spread	
	0	0	0	1	0	66	33	-1.0 % down spread	
	0	0	0	1	1	66	33	-1.5 % down spread	
	0	0	1	0	0	66	33	±0.25 % center spread	
	0	0	1	0	1	66	33	±0.5 % center spread	
	0	0	1	1	0	66	33	±1.0 % center spread	
	0	0	1	1	1	66.6	33.3	±1.5 % center spread	
	0	1	0	0	0	67.32	33.66	2% over-clocking	
	0	1	0	0	1	68.64	34.32	4% over-clocking	
	0	1	0	1	0	69.96	34.98	6% over-clocking	
	0	1	0	1	1	72.6	36.3	10% over-clocking	
	0	1	1	0	0	65.27	32.63	2% under- clocking	
	0	1	1	0	1	63.96	31.97	2% under- clocking	
	0	1	1	1	0	62.6	31.3	2% under- clocking	
	0	1	1	1	1	60	30	2% under- clocking	
	1	0	0	0	0	66.6	33.3	-1.4 % down spread	
	1	0	0	0	1	66.6	33.3	-1.6 % down spread	
	1	0	0	1	0	66.6	33.3	-1.8 % down spread	
	1	0	0	1	1	66.6	33.3	-2.0 % down spread	
1	0	1	0	0	66.6	33.3	± 1.4 % center spread		
1	0	1	0	1	66.6	33.3	± 1.6 % center spread		
1	0	1	1	0	66.6	33.3	±1.8 % center spread		
1	0	1	1	1	66.6	33.3	± 2.0 % center spread		
Bit3	0-Frequency and Spread is selected by hardware select. Latched input 1-Frequency is selected by Bit2, 7:4								0
Bit1	0-Normal 1-Spread spectrum Enabled								0
Bit0	0-Running 1-Tristate all outputs								0



ICS951601

Preliminary Product Preview

Byte 1: PCI1A Stop Clocks Register (1 = enable, 0 = disable)

Bit	Pin #	PWD	Description
Bit 7	24	1	PCI1A_7
Bit 6	23	1	PCI1A_6
Bit 5	20	1	PCI1A_5
Bit 4	19	1	PCI1A_4
Bit 3	16	1	PCI1A_3
Bit 2	15	1	PCI1A_2
Bit 1	12	1	PCI1A_1
Bit 0	11	1	PCI1A_0

Byte 2: PCI2A Stop Clocks Register (1 = enable, 0 = disable)

Bit	Pin #	PWD	Description
Bit 7	35	1	PCI2A_2
Bit 6	34	1	PCI2A_1
Bit 5	31	1	PCI2A_0
Bit 4	29	1	PCI1B_2
Bit 3	28	1	PCI1B_1
Bit 2	25	1	PCI1B_0
Bit 1	-	X	Reserved
Bit 0	-	X	Reserved

Byte 3: PCI2B Stop Clocks Register (1 = enable, 0 = disable)

Bit	Pin #	PWD	Description
Bit 7	41	1	PCI2B_2
Bit 6	40	1	PCI2B_1
Bit 5	37	1	PCI2B_0
Bit 4	-	X	Reserved
Bit 3	-	X	Reserved
Bit 2	-	X	Reserved
Bit 1	-	X	Reserved
Bit 0	-	X	Reserved

Byte 4: Reserved Register (1 = enable, 0 = disable)

Bit	Pin #	PWD	Description
Bit 7	48	1	48MHz
Bit 6	1	1	REF0
Bit 5	-	X	Reserved
Bit 4	-	X	Reserved
Bit 3	-	X	Reserved
Bit 2	-	X	Reserved
Bit 1	-	X	Reserved
Bit 0	-	X	Reserved

Byte 5: Latched Input Read Back Register (1 = enable, 0 = disable)

Bit	Pin #	PWD	Description
Bit7	-	X	SEL2B
Bit6	-	X	SEL1B
Bit5	-	X	SEL2A
Bit4	-	X	SEL1A
Bit3	-	X	Reserved
Bit2	-	X	Reserved
Bit1	-	X	Reserved
Bit0	-	X	Reserved

Note: PWD = Power-Up Default

Byte 6: Reserved for Byte Count Register (1 = enable, 0 = disable)

Bit	Pin #	PWD	Description
Bit7	-	0	Reserved for read byte count
Bit6	-	0	Reserved
Bit5	-	0	Reserved
Bit4	-	0	Reserved
Bit3	-	0	Reserved
Bit2	-	1	Reserved
Bit1	-	1	Reserved
Bit0	-	0	Reserved

ICS951601

Preliminary Product Preview



Absolute Maximum Ratings

Supply Voltage	5.5 V
Logic Inputs	GND -0.5 V to V _{DD} +0.5 V
Ambient Operating Temperature	0°C to +70°C
Storage Temperature	-65°C to +150°C
Case Temperature	115°C

Stresses above those listed under *Absolute Maximum Ratings* may cause permanent damage to the device. These ratings are stress specifications only and functional operation of the device at these or any other conditions above those listed in the operational sections of the specifications is not implied. Exposure to absolute maximum rating conditions for extended periods may affect product reliability.

Electrical Characteristics - Input/Supply/Common Output Parameters

T_A = 0 - 70°C; V_{DD}, V_{DDL} = 3.3 V +/-5% (unless otherwise stated)

PARAMETER	SYMBOL	CONDITIONS	MIN	TYP	MAX	UNITS
Input High Voltage	V _{IH}		2		V _{DD} + 0.3	V
Input Low Voltage	V _{IL}		V _{SS} - 0.3		0.8	V
Input High Current	I _{IH}	V _{IN} = V _{DD}			5	mA
Input Low Current	I _{IL1}	V _{IN} = 0 V; Inputs with no pull-up resistors	-5			mA
Input Low Current	I _{IL2}	V _{IN} = 0 V; Inputs with pull-up resistors	-200			mA
Operating Supply Current	I _{DD3.3OP100}	C _L = 0 pF; Select @ 100 MHz			160	mA
	I _{DD3.3OP133}	C _L = 0 pF; Select @ 133 MHz			160	mA
Input frequency	F _i	V _{DD} = 3.3 V;	11	14.318	16	MHz
Input Capacitance ¹	C _{IN}	Logic Inputs			5	pF
	C _{INX}	X1 & X2 pins	27		45	pF
Transition Time ¹	T _{trans}	To 1st crossing of target Freq.			3	ms
Settling Time ¹	T _s	From 1st crossing to 1% target Freq.			3	ms
Clk Stabilization ¹	T _{STAB}	From V _{DD} = 3.3 V to 1% target Freq.			3	ms

¹Guaranteed by design, not 100% tested in production.

Electrical Characteristics - Input/Supply/Common Output Parameters

T_A = 0 - 70°C; V_{DD} = 3.3 V +/-5%; V_{DDL} = 2.5 V +/-5% (unless otherwise stated)

PARAMETER	SYMBOL	CONDITIONS	MIN	TYP	MAX	UNITS
Operating Supply Current	I _{DD2.5OP100}	C _L = 0 pF; Select @ 100 MHz		16	75	mA
	I _{DD2.5OP133}	C _L = 0 pF; Select @ 133 MHz		19	90	mA
Power Down Supply Current	I _{DD2.5PD}	C _L = 0 pF; PWRDWN# = 0		0.1	100	μA

¹Guaranteed by design, not 100% tested in production.



Electrical Characteristics - PCI

$T_A = 0 - 70^\circ\text{C}$; $V_{DD} = 3.3\text{ V} \pm 5\%$, $V_{DDL} = 2.5\text{ V} \pm 5\%$; $C_L = 30\text{ pF}$ (unless otherwise stated)

PARAMETER	SYMBOL	CONDITIONS	MIN	TYP	MAX	UNITS
Output High Voltage	V_{OH1}	$I_{OH} = -11\text{ mA}$	2.4			V
Output Low Voltage	V_{OL1}	$I_{OL} = 9.4\text{ mA}$			0.4	V
Output High Current	I_{OH1}	$V_{OH} = 2.0\text{ V}$			-22	mA
Output Low Current	I_{OL1}	$V_{OL} = 0.8\text{ V}$	16			mA
Rise Time ¹	t_{r1}	$V_{OL} = 0.4\text{ V}$, $V_{OH} = 2.4\text{ V}$			2	ns
Fall Time ¹	t_{f1}	$V_{OH} = 2.4\text{ V}$, $V_{OL} = 0.4\text{ V}$			2	ns
Duty Cycle ¹	d_{t1}	$V_T = 1.5\text{ V}$	45		55	%
Skew ¹	t_{sk1}	$V_T = 1.5\text{ V} @ 33.33$			170	ps
Skew ¹	t_{sk2}	$V_T = 1.5\text{ V} @ 66.66$			340	ps
Jitter, Cycle-to-cycle ¹	$T_{j\text{cyc-cyc}1}$	$V_T = 1.5\text{ V}$			500	ps

¹Guaranteed by design, not 100% tested in production.

Electrical Characteristics - 48 MHz

$T_A = 0 - 70^\circ\text{C}$; $V_{DD} = 3.3\text{ V} \pm 5\%$; $V_{DDL} = 2.5\text{ V} \pm 5\%$; $C_L = 20\text{ pF}$ (unless otherwise stated)

PARAMETER	SYMBOL	CONDITIONS	MIN	TYP	MAX	UNITS
Output High Voltage	V_{OH5}	$I_{OH} = -16\text{ mA}$	2.4			V
Output Low Voltage	V_{OL5}	$I_{OL} = 9\text{ mA}$			0.4	V
Output High Current	I_{OH5}	$V_{OH} = 2.0\text{ V}$			-22	mA
Output Low Current	I_{OL5}	$V_{OL} = 0.8\text{ V}$	16			mA
Rise Time ¹	t_{r5}	$V_{OL} = 0.4\text{ V}$, $V_{OH} = 2.4\text{ V}$			4	ns
Fall Time ¹	t_{f5}	$V_{OH} = 2.4\text{ V}$, $V_{OL} = 0.4\text{ V}$			4	ns
Duty Cycle ¹	d_{t5}	$V_T = 1.5\text{ V}$	45		55	%
Jitter, Cycle-to-cycle ¹	$T_{j\text{cyc-cyc}5}$	$V_T = 1.5\text{ V}$			350	ps

¹Guaranteed by design, not 100% tested in production.

ICS951601

Preliminary Product Preview



Electrical Characteristics - REF

$T_A = 0 - 70^\circ\text{C}$; $V_{DD} = 3.3\text{ V} \pm 5\%$, $V_{DDL} = 2.5\text{ V} \pm 5\%$; $C_L = 20\text{ pF}$ (unless otherwise stated)

PARAMETER	SYMBOL	CONDITIONS	MIN	TYP	MAX	UNITS
Output High Voltage	V_{OH5}	$I_{OH} = -16\text{ mA}$	2.4			V
Output Low Voltage	V_{OL5}	$I_{OL} = 9\text{ mA}$			0.4	V
Output High Current	I_{OH5}	$V_{OH} = 2.0\text{ V}$			-22	mA
Output Low Current	I_{OL5}	$V_{OL} = 0.8\text{ V}$	16			mA
Rise Time ¹	t_{r5}	$V_{OL} = 0.4\text{ V}$, $V_{OH} = 2.4\text{ V}$			4	ns
Fall Time ¹	t_{f5}	$V_{OH} = 2.4\text{ V}$, $V_{OL} = 0.4\text{ V}$			4	ns
Duty Cycle ¹	d_{t5}	$V_T = 1.5\text{ V}$	45		55	%
Jitter, Cycle-to-cycle ¹	$T_{jyc-cyc5}$	$V_T = 1.5\text{ V}$			500	ps

¹Guaranteed by design, not 100% tested in production.

TARGIFICATION
SUBJECT TO CHANGE
WITH FULL
PRODUCT
CHARACTERIZATION



ICS951601 Preliminary Product Preview

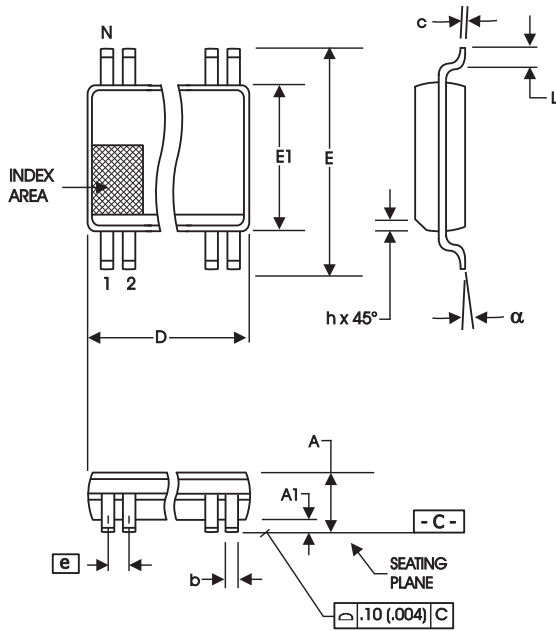

300 mil SSOP Package

SYMBOL	In Millimeters COMMON DIMENSIONS		In Inches COMMON DIMENSIONS	
	MIN	MAX	MIN	MAX
A	2.41	2.80	.095	.110
A1	0.20	0.40	.008	.016
b	0.20	0.34	.008	.0135
c	0.13	0.25	.005	.010
D	SEE VARIATIONS		SEE VARIATIONS	
E	10.03	10.68	.395	.420
E1	7.40	7.60	.291	.299
e	0.635 BASIC		0.025 BASIC	
h	0.38	0.64	.015	.025
L	0.50	1.02	.020	.040
N	SEE VARIATIONS		SEE VARIATIONS	
α	0°	8°	0°	8°

VARIATIONS

N	D mm.		D (inch)	
	MIN	MAX	MIN	MAX
48	15.75	16.00	.620	.630

Reference Doc.: JEDEC Publication 95, MO-18

10-0034

Ordering Information

ICS951601yFLF

Example:

ICS XXXX y F - PPP LF

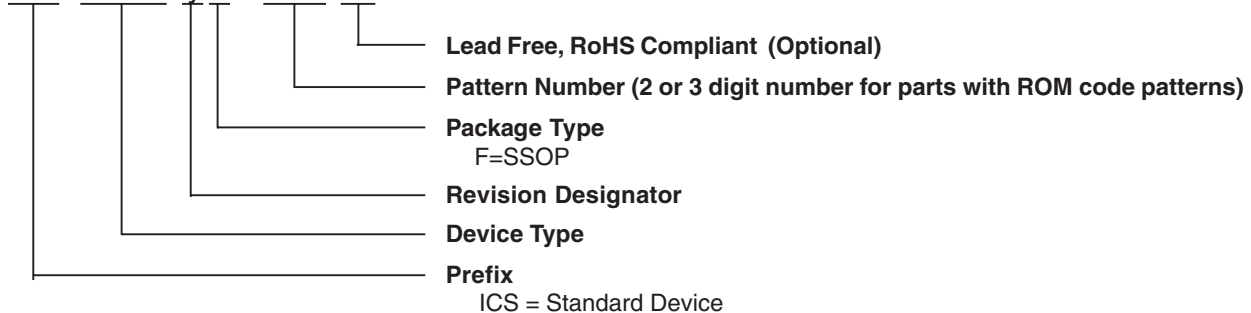

0663C—10/04/05

ICS951601

Preliminary Product Preview



Revision History

Rev.	Issue Date	Description	Page #
C	10/4/2005	Added LF to Ordering Information	9