



Chipsmall Limited consists of a professional team with an average of over 10 year of expertise in the distribution of electronic components. Based in Hongkong, we have already established firm and mutual-benefit business relationships with customers from,Europe,America and south Asia,supplying obsolete and hard-to-find components to meet their specific needs.

With the principle of “Quality Parts,Customers Priority,Honest Operation,and Considerate Service”,our business mainly focus on the distribution of electronic components. Line cards we deal with include Microchip,ALPS,ROHM,Xilinx,Pulse,ON,Everlight and Freescale. Main products comprise IC,Modules,Potentiometer,IC Socket,Relay,Connector.Our parts cover such applications as commercial,industrial, and automotives areas.

We are looking forward to setting up business relationship with you and hope to provide you with the best service and solution. Let us make a better world for our industry!



Contact us

Tel: +86-755-8981 8866 Fax: +86-755-8427 6832

Email & Skype: info@chipsmall.com Web: www.chipsmall.com

Address: A1208, Overseas Decoration Building, #122 Zhenhua RD., Futian, Shenzhen, China



REV - DESCRIPT - DATE - APPRVD
.
.
.

USB-A PLUG,
SEE P-ID651-000
FOR MORE INFORMATION

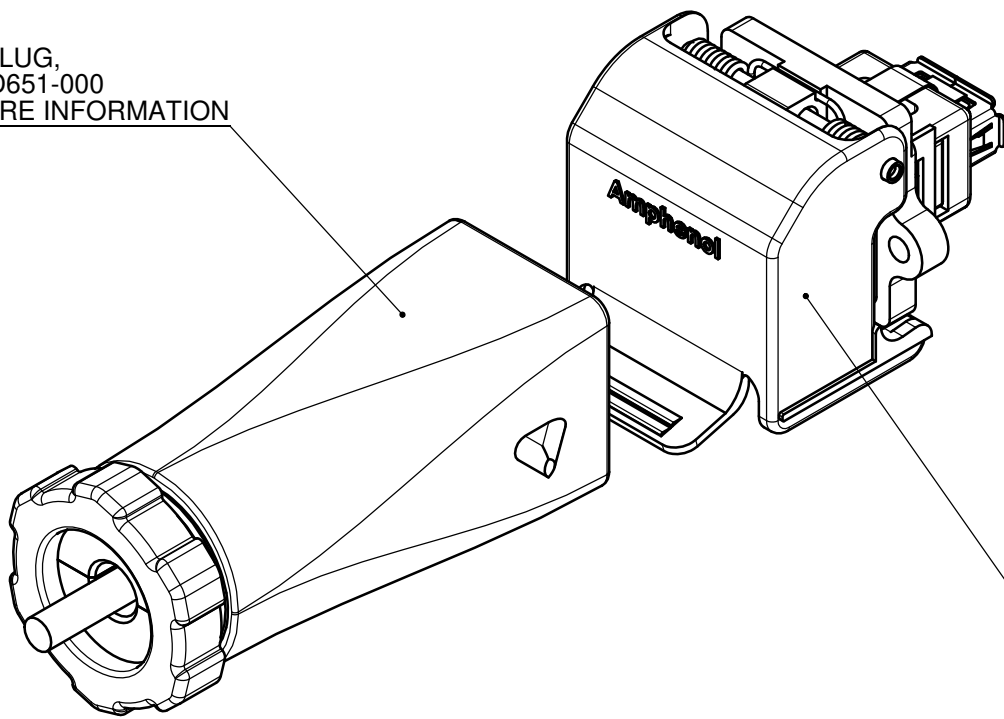

USB-A RECEPTACLE,
SEE P-ID451-000
FOR MORE INFORMATION

NOTES:

1. OPERATING TEMPERATURE: -40°C TO +85°C.
2. ENVIROMENT PERFORMANCE: IP67.
3. CONNECTOR IS ROHS COMPLIANT PER EU DIRECTIVE 2002/95/EC AND AMENDMENTS.
4. PART NUMBER FOR ORDER IS ID751-000.



UNLESS OTHERWISE SPECIFIED DIMENSIONS ARE IN MILLIMETER TOLERANCES ARE:		APPROVALS	DATE	Amphenol Canada Corp.	
		DRAWN S.SEMENOV	FEB16/07		
DECIMALS .XX ± .10 .X ± .25	ANGLES ± 1°	DESIGNED S.SEMENOV	FEB16/07	TITLE USB A RECEPTACLE AND PLUG	
MATERIAL AND FINISH		CHECKED		SIZE C	DWG. NO. P-ID751-000
REF.		QA APP'D		REV. A	
CODE IDENT. NO.		IE APP'D		SCALE 2.5:1	PROJECT ID
		DWG APP'D A.GREEN	FEB16/07	SHEET 1 OF 2	

DO NOT SCALE DRAWING
THIS DOCUMENT CONTAINS PROPRIETARY INFORMATION AND SUCH INFORMATION MAY NOT BE DISCLOSED TO OTHERS FOR ANY PURPOSE
OR USED FOR MANUFACTURING PURPOSES WITHOUT PERMISSION FROM AMPHENOL CANADA CORP.

REV	DESCRIPT	DATE	APPRVD

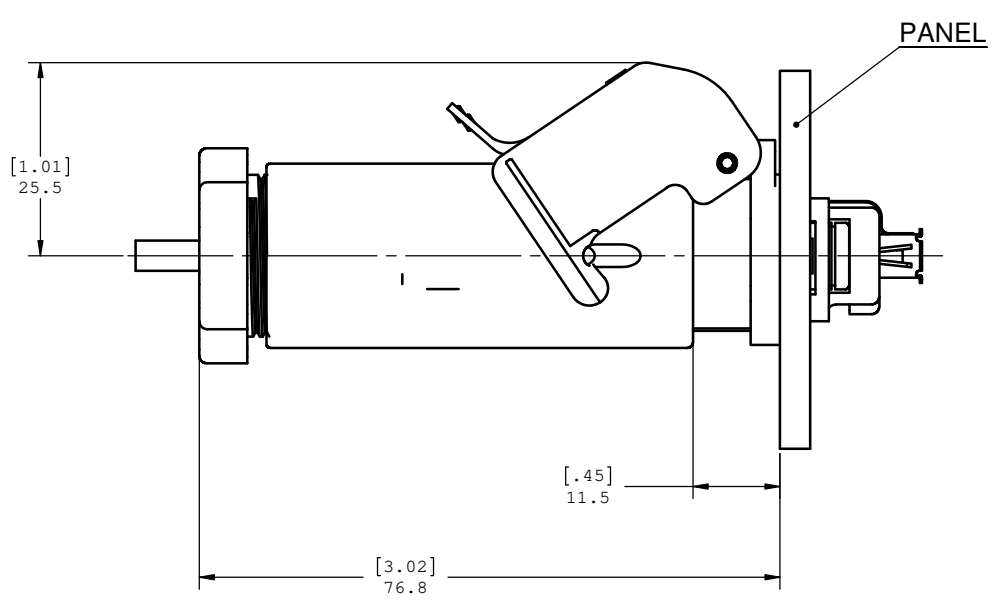
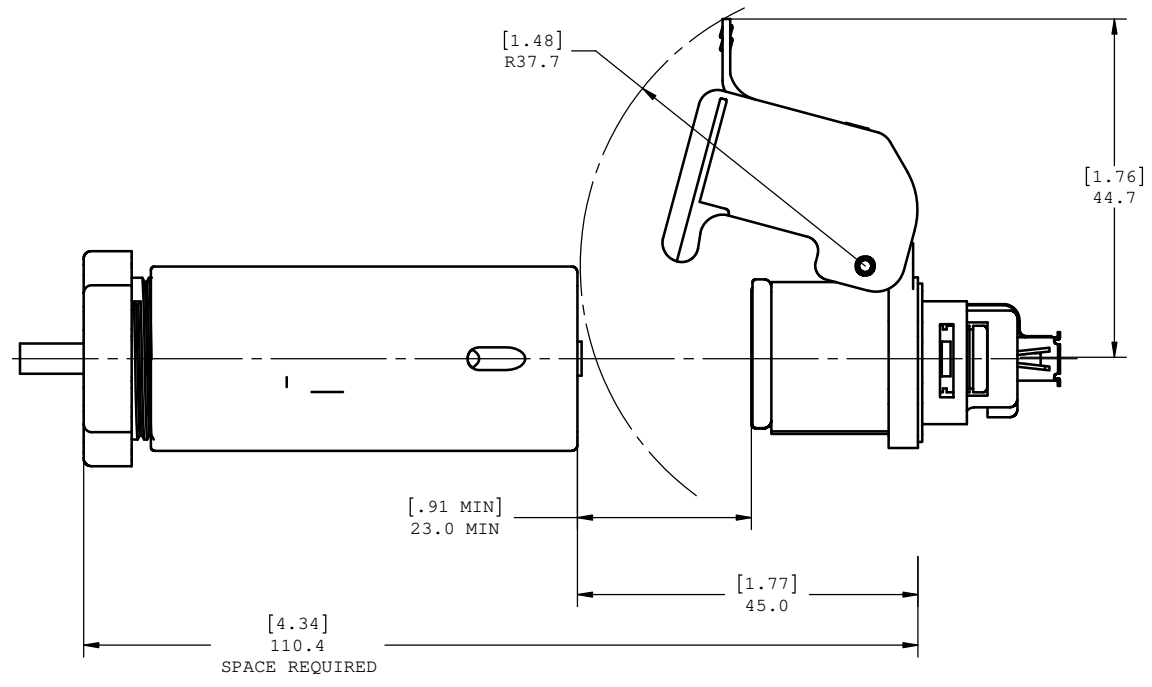

UNLESS OTHERWISE SPECIFIED DIMENSIONS ARE IN MILLIMETER TOLERANCES ARE:		APPROVALS	DATE	Amphenol Canada Corp.	
DECIMALS .XX ±.10 .X ±.25		DRAWN S.SEMENOV	FEB16/07		
ANGLES ± 1°		DESIGNED S.SEMENOV	FEB16/07	TITLE USB A RECEPTACLE AND PLUG	
MATERIAL AND FINISH		CHECKED		SIZE C	DWG. NO. P-ID751-000
REF.		QA APP'D		REV. A	
CODE IDENT. NO.		IE APP'D		SCALE 2:1	PROJECT ID
		DWG APP'D A.GREEN	FEB16/07	SHEET 2 OF 2	

DO NOT SCALE DRAWING
 THIS DOCUMENT CONTAINS PROPRIETARY INFORMATION AND SUCH INFORMATION MAY NOT BE DISCLOSED TO OTHERS FOR ANY PURPOSE
 OR USED FOR MANUFACTURING PURPOSES WITHOUT PERMISSION FROM AMPHENOL CANADA CORP.