



Chipsmall Limited consists of a professional team with an average of over 10 year of expertise in the distribution of electronic components. Based in Hongkong, we have already established firm and mutual-benefit business relationships with customers from,Europe,America and south Asia,supplying obsolete and hard-to-find components to meet their specific needs.

With the principle of "Quality Parts,Customers Priority,Honest Operation,and Considerate Service",our business mainly focus on the distribution of electronic components. Line cards we deal with include Microchip,ALPS,ROHM,Xilinx,Pulse,ON,Everlight and Freescale. Main products comprise IC,Modules,Potentiometer,IC Socket,Relay,Connector.Our parts cover such applications as commercial,industrial, and automotives areas.

We are looking forward to setting up business relationship with you and hope to provide you with the best service and solution. Let us make a better world for our industry!



## Contact us

Tel: +86-755-8981 8866 Fax: +86-755-8427 6832

Email & Skype: info@chipsmall.com Web: www.chipsmall.com

Address: A1208, Overseas Decoration Building, #122 Zhenhua RD., Futian, Shenzhen, China





# LOW-VOLTAGE 10-BIT BUS SWITCH WITH ACTIVE HIGH AND LOW ENABLES

**IDT74CBTLV3862**

## FEATURES:

- 5Ω A/B bi-directional switch
- Isolation Under Power-Off Conditions
- Over-voltage tolerant
- Latch-up performance exceeds 100mA
- Vcc = 2.3V - 3.6V, normal range
- ESD >2000V per MIL-STD-883, Method 3015; >200V using machine model (C = 200pF, R = 0)
- Available in SSOP, QSOP, and TSSOP packages

## APPLICATIONS:

- 3.3V High Speed Bus Switching and Bus Isolation

## DESCRIPTION:

The CBTLV3862 provides ten bits of high-speed bus switching with low on-state resistance of the switch allowing connections to be made with minimal propagation delay.

The device is organized as one 10-bit bus switch. The switches are controlled by independent active-low enable ( $\overline{OE}$ ) and active-high enable (OE) controls.

To ensure the high-impedance state during power up or power down,  $\overline{OE}$  should be tied to Vcc through a pullup resistor; the minimum value of the resistor is determined by the current-sinking capability of the driver, and OE should be tied to GND.

## FUNCTIONAL BLOCK DIAGRAM

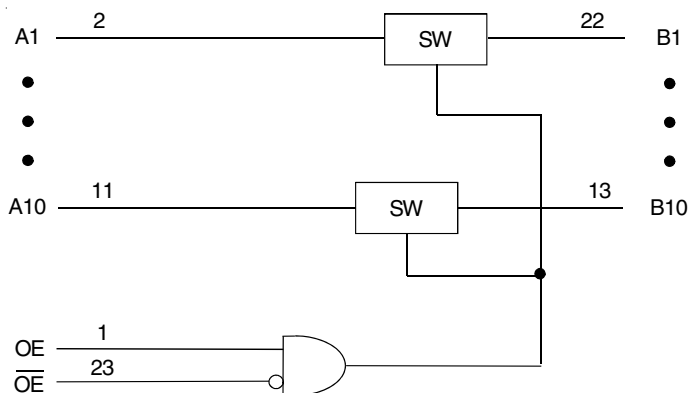

## SIMPLIFIED SCHEMATIC, EACH SWITCH

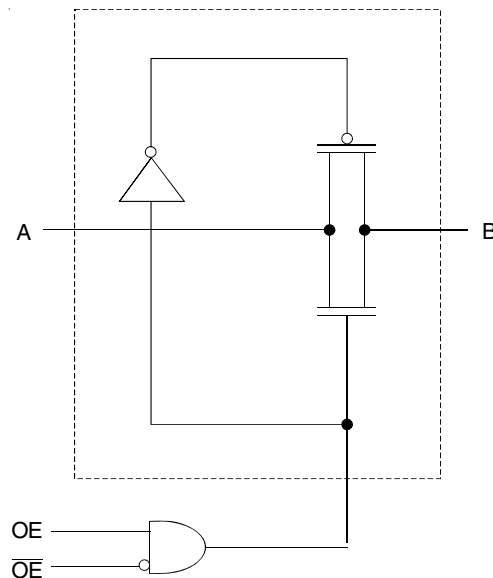

## PIN CONFIGURATION

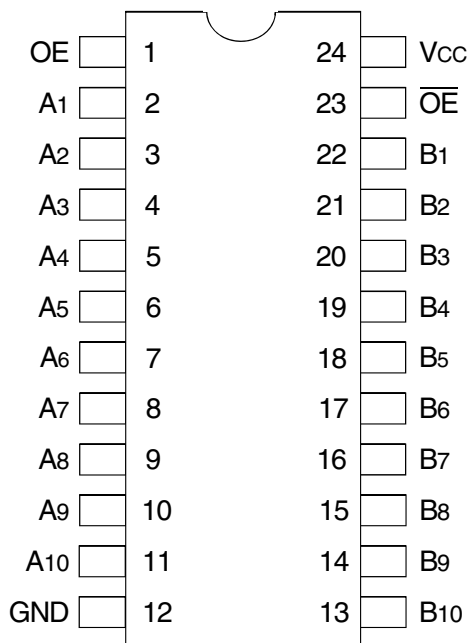

SSOP/ QSOP/ TSSOP  
 TOP VIEW

## ABSOLUTE MAXIMUM RATINGS<sup>(1)</sup>

Symbol	Description	Max.	Unit
V <sub>CC</sub>	Supply Voltage Range	-0.5 to 4.6	V
V <sub>I</sub>	Input Voltage Range	-0.5 to 4.6	V
	Continuous Channel Current	128	mA
I <sub>IK</sub>	Input Clamp Current, V <sub>I/O</sub> < 0	-50	mA
T <sub>STG</sub>	Storage Temperature Range	-65 to +150	°C

**NOTE:**

- Stresses greater than those listed under ABSOLUTE MAXIMUM RATINGS may cause permanent damage to the device. This is a stress rating only and functional operation of the device at these or any other conditions above those indicated in the operational sections of this specification is not implied. Exposure to absolute maximum rating conditions for extended periods may affect reliability.

## FUNCTION TABLE<sup>(1)</sup>

Inputs		Function
OE	$\overline{OE}$	
L	L	Disconnect
L	H	Disconnect
H	L	A Port = B Port
H	H	Disconnect

**NOTE:**

- H = HIGH Voltage Level  
 L = LOW Voltage Level

## OPERATING CHARACTERISTICS<sup>(1)</sup>

Symbol	Parameter	Test Conditions	Min.	Max.	Unit
V <sub>CC</sub>	Supply Voltage		2.3	3.6	V
V <sub>IH</sub>	High-Level Control Input Voltage	V <sub>CC</sub> = 2.3V to 2.7V	1.7	—	V
		V <sub>CC</sub> = 2.7V to 3.6V	2	—	
V <sub>IL</sub>	Low-Level Control Input Voltage	V <sub>CC</sub> = 2.3V to 2.7V	—	0.7	V
		V <sub>CC</sub> = 2.7V to 3.6V	—	0.8	
T <sub>A</sub>	Operating Free-Air Temperature		-40	+85	°C

**NOTE:**

- All unused control inputs of the device must be held at V<sub>CC</sub> or GND to ensure proper device operation.

## DC ELECTRICAL CHARACTERISTICS OVER OPERATING RANGE

Following Conditions Apply Unless Otherwise Specified:

Operating Condition: TA = -40°C to +85°C

Symbol	Parameter	Test Conditions	Min.	Typ. <sup>(1)</sup>	Max.	Unit	
V <sub>IK</sub>	Control Inputs, Data I/O	V <sub>CC</sub> = 3V, I <sub>I</sub> = -18mA	—	—	-1.2	V	
I <sub>I</sub>	Control Inputs, Data I/O	V <sub>CC</sub> = 3.6V, V <sub>I</sub> = V <sub>CC</sub> or GND	—	—	±1	μA	
I <sub>OZ</sub>	Data I/O	V <sub>CC</sub> = 3.6V, V <sub>O</sub> = 0V or 3.6V switch disabled	—	—	5	μA	
I <sub>OFF</sub>		V <sub>CC</sub> = 0V, V <sub>I</sub> or V <sub>O</sub> = 0V or 3.6V	—	—	50	μA	
I <sub>CC</sub>		V <sub>CC</sub> = 3.6V, I <sub>O</sub> = 0, V <sub>I</sub> = V <sub>CC</sub> or GND	—	—	10	μA	
ΔI <sub>CC</sub> <sup>(2)</sup>	Control Inputs	V <sub>CC</sub> = 3.6V, one input at 3V, other inputs at V <sub>CC</sub> or GND	—	—	300	μA	
C <sub>I</sub>	Control Inputs	V <sub>I</sub> = 3V or 0	—	4	—	pF	
C <sub>I(OFF)</sub>		V <sub>O</sub> = 3V or 0 (switch off)	—	6	—	pF	
R <sub>ON</sub> <sup>(3)</sup>	V <sub>CC</sub> = 2.3V Typ. at V <sub>CC</sub> = 2.5V	V <sub>I</sub> = 0	I <sub>O</sub> = 64mA	—	5	8	Ω
			I <sub>O</sub> = 24mA	—	5	8	
	V <sub>CC</sub> = 3V	V <sub>I</sub> = 1.7V	I <sub>O</sub> = 15mA	—	27	40	
			V <sub>I</sub> = 0	I <sub>O</sub> = 64mA	—	5	
		V <sub>I</sub> = 2.4V		I <sub>O</sub> = 24mA	—	5	
			I <sub>O</sub> = 15mA	—	10	15	

### NOTES:

1. Typical Values are at V<sub>CC</sub> = 3.3V, +25°C ambient.
2. The increase in supply current is attributable to each input that is at the specified voltage level rather than V<sub>CC</sub> or GND.
3. This is measured by the voltage drop between the A and B terminals at the indicated current through the switch.

## SWITCHING CHARACTERISTICS

Symbol	Parameter	V <sub>CC</sub> = 2.5V ± 0.2V		V <sub>CC</sub> = 3.3V ± 0.3V		Unit
		Min.	Max.	Min.	Max.	
t <sub>PD</sub> <sup>(1)</sup>	Propagation Delay A to B or B to A	—	0.15	—	0.25	ns
t <sub>EN</sub>	Output Enable Time $\overline{OE}$ to A or B	1	4.5	1	4.2	ns
t <sub>DIS</sub>	Output Disable Time $\overline{OE}$ to A or B	1	5	1	5	ns
t <sub>EN</sub>	Output Enable Time OE to A or B	1	4.5	1	4.2	ns
t <sub>DIS</sub>	Output Disable Time OE to A or B	1	5	1	6	ns

### NOTE:

1. The propagation delay is the calculated RC time constant of the typical on-state resistance of the switch and the specified load capacitance when driven by an ideal voltage source (zero output impedance).

## TEST CIRCUITS AND WAVEFORMS

### TEST CONDITIONS

Symbol	$V_{CC}^{(1)}=3.3V\pm 0.3V$	$V_{CC}^{(2)}=2.5V\pm 0.2V$	Unit
$V_{LOAD}$	6	$2 \times V_{CC}$	V
$V_{IH}$	3	$V_{CC}$	V
$V_T$	1.5	$V_{CC} / 2$	V
$V_{LZ}$	300	150	mV
$V_{HZ}$	300	150	mV
$C_L$	50	30	pF

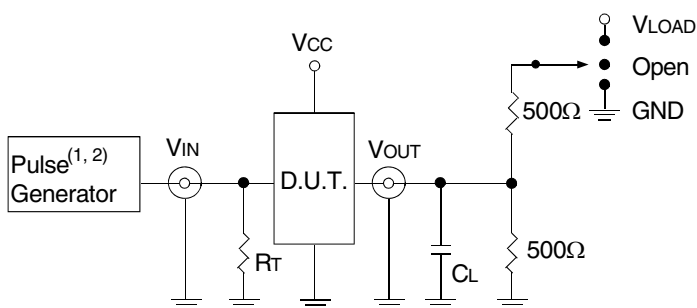
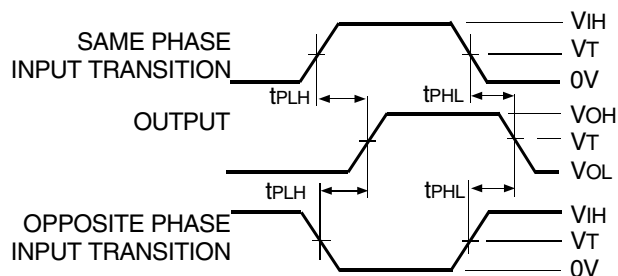

Test Circuits for All Outputs

#### DEFINITIONS:

$C_L$  = Load capacitance: includes jig and probe capacitance.  
 $R_T$  = Termination resistance: should be equal to  $Z_{OUT}$  of the Pulse Generator.

#### NOTES:

1. Pulse Generator for All Pulses: Rate  $\leq 10\text{MHz}$ ;  $t_r \leq 2.5\text{ns}$ ;  $t_f \leq 2.5\text{ns}$ .
2. Pulse Generator for All Pulses: Rate  $\leq 10\text{MHz}$ ;  $t_r \leq 2\text{ns}$ ;  $t_f \leq 2\text{ns}$ .

### SWITCH POSITION

Test	Switch
$t_{PLZ}/t_{PZL}$	$V_{LOAD}$
$t_{PHZ}/t_{PZH}$	GND
$t_{PD}$	Open

### Propagation Delay

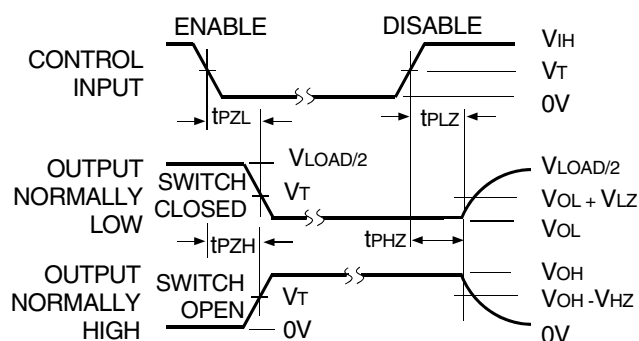

#### NOTE:

1. Diagram shown for input Control Enable-LOW and input Control Disable-HIGH.

### Enable and Disable Times

## ORDERING INFORMATION

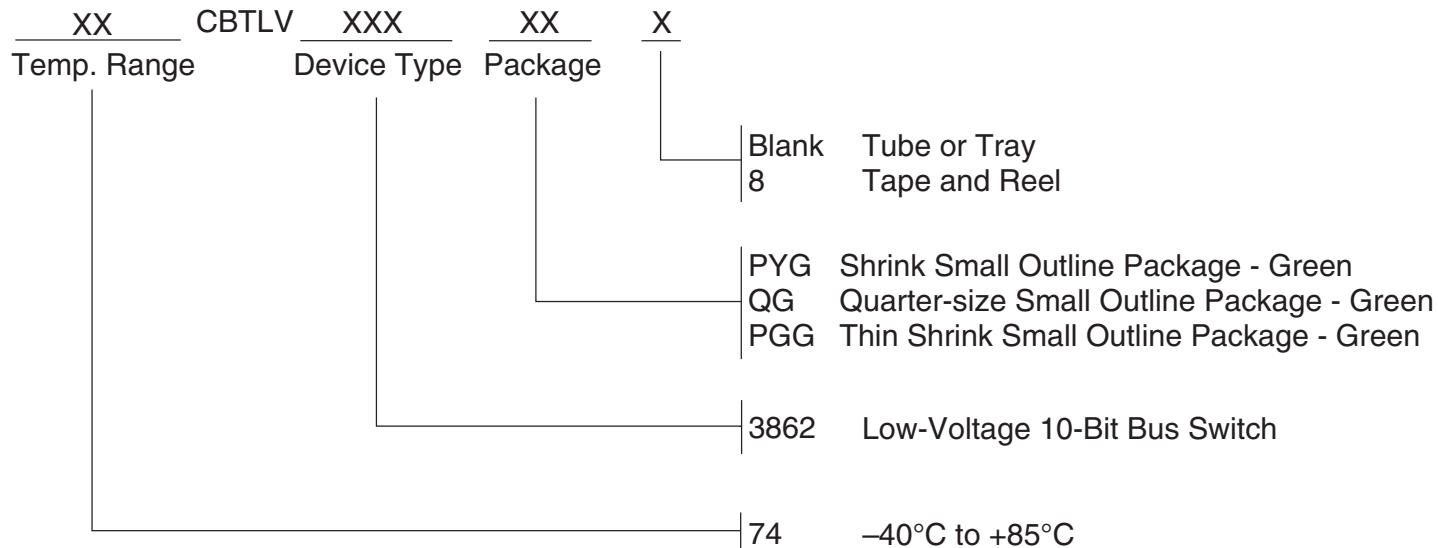

## Datasheet Document History

12/18/2014 Pg. 5 Updated the ordering information by removing the "IDT" notation, non RoHS part and by adding Tape and Reel information.



**CORPORATE HEADQUARTERS**  
 6024 Silver Creek Valley Road  
 San Jose, CA 95138

**for SALES:**  
 800-345-7015 or 408-284-8200  
 fax: 408-284-2775  
 www.idt.com

**for Tech Support:**  
 logichelp@idt.com