



Chipsmall Limited consists of a professional team with an average of over 10 year of expertise in the distribution of electronic components. Based in Hongkong, we have already established firm and mutual-benefit business relationships with customers from,Europe,America and south Asia,supplying obsolete and hard-to-find components to meet their specific needs.

With the principle of “Quality Parts,Customers Priority,Honest Operation,and Considerate Service”,our business mainly focus on the distribution of electronic components. Line cards we deal with include Microchip,ALPS,ROHM,Xilinx,Pulse,ON,Everlight and Freescale. Main products comprise IC,Modules,Potentiometer,IC Socket,Relay,Connector.Our parts cover such applications as commercial,industrial, and automotives areas.

We are looking forward to setting up business relationship with you and hope to provide you with the best service and solution. Let us make a better world for our industry!



## Contact us

Tel: +86-755-8981 8866 Fax: +86-755-8427 6832

Email & Skype: info@chipsmall.com Web: www.chipsmall.com

Address: A1208, Overseas Decoration Building, #122 Zhenhua RD., Futian, Shenzhen, China



# Plastic Optical Fiber Couplers (Splitters)



## DESCRIPTION

Fiber couplers, or splitters, are special fiber optic devices with one or more input fibers for distributing optical signals into two or more output fibers. The optical light is passively split into multiple output signals (fibers), each containing light with properties identical to the original except for reduced amplitude. Because the splitter is a passive device it is immune to EMI, consumes no electrical power and does not add noise to system design. The splitter's passive design is bi-directional and operationally independent of wavelength, constrained only by the physical properties of the PMMA fiber core.

Fiber couplers have input and output configurations defined as  $M \times N$ .  $M$  is the number of input ports and is one or greater.  $N$  is the number of output ports and is always equal to or greater than  $M$ . When there are multiple inputs, output signals are always a combination of the input signals – a coupler can also be considered a combiner.

Fiber optic couplers or splitters are available in a wide range of styles and sizes to split or combine light with minimal loss. All couplers are manufactured using a very simple proprietary process that produces reliable, low-cost devices. They are physically rugged and insensitive to operating temperatures. Couplers can be fabricated in custom fiber lengths and/ or with terminations of any type.

## APPLICATIONS

- ▶ Feedback Control Circuits
- ▶ Ethernet and Automotive LANs
- ▶ Medical Instruments
- ▶ Automotive Electronics
- ▶ Optical Sensors
- ▶ Wavelength Multiplexing
- ▶ Audio Systems
- ▶ Communications Systems

## FEATURES

- ◆ Light, Compact Design
- ◆ Standard Jacketed 1000  $\mu\text{m}$  Core Plastic Fiber Cable
- ◆ High Isolation
- ◆ Light-Tight Stainless Steel Housing
- ◆ Low Loss
- ◆ Excellent Temperature Stability
- ◆ Visible and IR Light-Compatible

## MAXIMUM RATINGS

( $T_A = 25^\circ\text{C}$ )

Operating Temperature Range  
( $T_{OP}$ ) .....  $-55^\circ$  to  $85^\circ\text{C}$

Storage Temperature Range  
( $T_{STG}$ ) .....  $-55^\circ$  to  $85^\circ\text{C}$

Fiber Bending Radius ..... 25 mm

Fiber Tensile Strength ..... 5 kg

## FIBER CHARACTERISTICS ( $T_A = 25^\circ\text{C}$ )

**MATERIAL:** Fiber couplers are manufactured with Mitsubishi GH4001 1000  $\mu\text{m}$  core jacketed step-index optical fiber. See website for detailed fiber specifications.

Parameter	Symbol	Min.	Typ.	Max.	Unit
Fiber Attenuation (650 nm light)	-	-	.14	.16	dB/ m
Fiber N/ A	-	-	.51	-	-
Core Refractive Index	-	-	1.492	-	-
Cladding Refractive Index	-	-	1.402	--	-

# Plastic Optical Fiber Couplers (Splitters)

## CHARACTERISTICS

STOCK NUMBER	PORTS	SPLITTING RATIO %	INSERTION LOSS (MAX)	EXCESS LOSS (MAX)
IF-540	2 X 2	50:50	Port A - Port C 5.6 dB Port A - Port D 3.7 dB Port B - Port C 3.7 dB Port B - Port D 5.6 dB	Port A 1.6 dB Port B 1.6 dB
IF-541	2 X 2	80:20	Port A - Port C 9.9 dB Port A - Port D 2.9 dB Port B - Port C 2.9 dB Port B - Port D 9.9 dB	Port A 1.7 dB Port B 1.7 dB
IF-542	2 X 2	90:10	Port A - Port C 1.5 dB Port A - Port D 2.5 dB Port B - Port C 2.4 dB Port B - Port D 1.5 dB	Port A 2.0 dB Port B 2.0 dB
IF-562	1 X 2	50:50	Port A - Port C 5.6 dB Port A - Port D 3.7 dB	Port A 1.6 dB
IF-543	1 X 3	33:33:33	Port A - Port B 8.2 dB Port A - Port C 8.2 dB Port A - Port D 8.2 dB	Port A 2.2 dB
IF-544	4 X 4	25:25:25:25	— —	— —

All devices are available with ST®, SMA or Versalink fiber terminations.

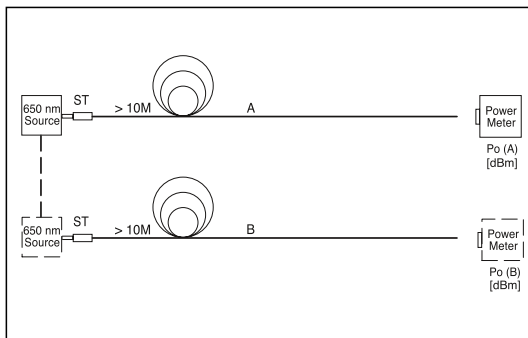

FIGURE 1. Reference measurement - (pre-fused)

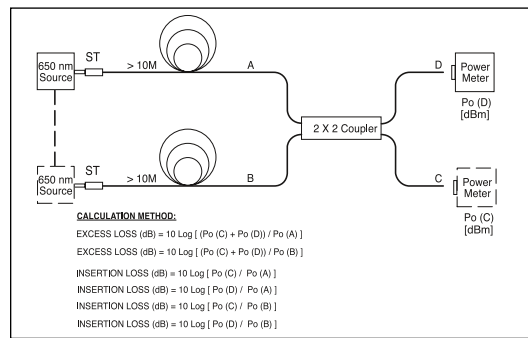

FIGURE 2. Excess & insertion loss measurement - (post-fused)

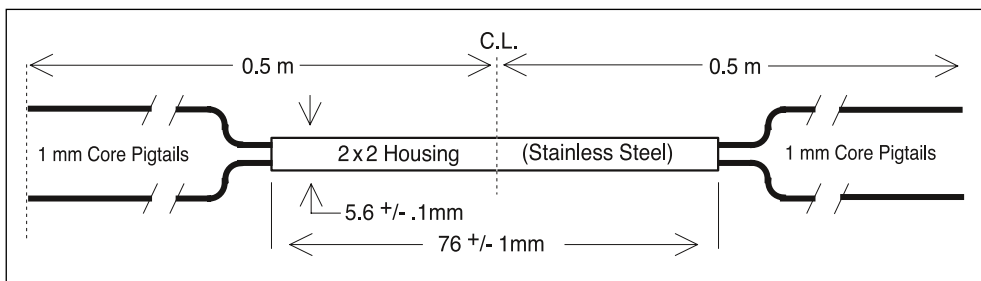

FIGURE 3. Overall Dimensions for 2 X 2 Coupler