



Chipsmall Limited consists of a professional team with an average of over 10 year of expertise in the distribution of electronic components. Based in Hongkong, we have already established firm and mutual-benefit business relationships with customers from,Europe,America and south Asia,supplying obsolete and hard-to-find components to meet their specific needs.

With the principle of “Quality Parts,Customers Priority,Honest Operation,and Considerate Service”,our business mainly focus on the distribution of electronic components. Line cards we deal with include Microchip,ALPS,ROHM,Xilinx,Pulse,ON,Everlight and Freescale. Main products comprise IC,Modules,Potentiometer,IC Socket,Relay,Connector.Our parts cover such applications as commercial,industrial, and automotives areas.

We are looking forward to setting up business relationship with you and hope to provide you with the best service and solution. Let us make a better world for our industry!



## Contact us

Tel: +86-755-8981 8866 Fax: +86-755-8427 6832

Email & Skype: info@chipsmall.com Web: www.chipsmall.com

Address: A1208, Overseas Decoration Building, #122 Zhenhua RD., Futian, Shenzhen, China



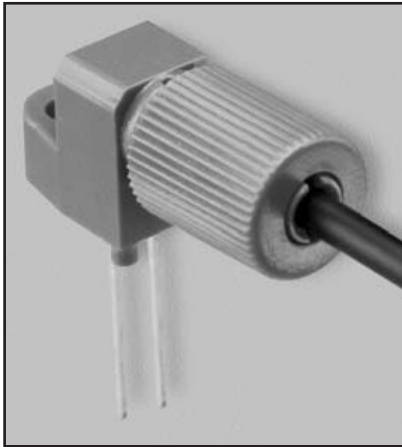

## DESCRIPTION

The IF-E97 is a high-optical-output, visible red LED housed in a “connector-less” style plastic fiber optic package. The output spectrum is produced by a GaAlAs die which peaks at 660 nm, one of the optimal transmission windows of PMMA plastic optical fiber. The device package features an internal micro-lens and a precision-molded PBT housing to ensure efficient optical coupling with standard 1000  $\mu\text{m}$  core plastic fiber cable.

## APPLICATION HIGHLIGHTS

The high output and excellent linearity of the IF-E97 make it suitable for analog and digital data links. The IF-E97 can achieve data rates of 1 Mbps when used with an IF-D96 photologic detector. The visible red light has low attenuation in PMMA plastic fiber and aids in troubleshooting installations. The drive circuit design is simpler than required for laser diodes, making the IF-E97 the lowest cost selection for a variety of analog and digital applications requiring maximum operating distance.

## APPLICATIONS

- ▶ Low Cost Analog and Digital Data Links
- ▶ Automotive Electronics
- ▶ Digitized Audio
- ▶ Medical Instruments
- ▶ PC-to-Peripheral Data Links
- ▶ Robotics Communications
- ▶ Motor Controller Triggering
- ▶ EMC/EMI Signal Isolation
- ▶ Local Area Networks
- ▶ Intra-System Links: Board-to-Board, Rack-to-Rack

## FEATURES

- ◆ High Optical Power
- ◆ Visible Red Output Aids Troubleshooting
- ◆ Low Transmission Loss with PMMA Plastic Fiber
- ◆ No Optical Design required
- ◆ Mates with standard 1000  $\mu\text{m}$  Core Jacketed Plastic Fiber Cable
- ◆ Internal Micro-Lens for Efficient Optical Coupling
- ◆ Inexpensive Plastic Connector Housing
- ◆ Connector-Less Fiber Termination
- ◆ Light-Tight Housing Provides Interference-Free Transmission
- ◆ RoHS compliant

## MAXIMUM RATINGS

( $T_A=25^\circ\text{C}$ )

Operating and Storage Temperature Range ( $T_{OP}, T_{STG}$ )	.....-40° to 85°C
Junction Temperature ( $T_J$ )	.....85°C
Soldering Temperature (2 mm from case bottom) ( $T_S$ ) $t \leq 5$ s	.....240°C
Reverse Voltage ( $V_R$ )	.....5 V
Power Dissipation ( $P_{TOT}$ ) $T_A=25^\circ\text{C}$	.....100 mW
De-rate Above 25°C	.....1.33 mW/°C
Forward Current, DC ( $I_F$ )	.....40 mA
Surge Current ( $I_{FSM}$ ) $t \leq 10 \mu\text{sec}$	.....200 mA

## CHARACTERISTICS ( $T_A=25^\circ\text{C}$ )

Parameter	Symbol	Min.	Typ.	Max.	Unit
Peak Wavelength	$\lambda_{PEAK}$	650	660	670	nm
Spectral Bandwidth (50% of $I_{MAX}$ )	$\Delta\lambda$	-	40	-	nm
Output Power Coupled into Plastic Fiber (1 mm core diameter). Distance Lens to Fiber $\leq 0.1$ mm, 1 m polished fiber, $I_F=20$ mA	$\Phi_{min}$	250 -6.0	325 -4.9	425 -3.7	$\mu\text{W}$ dBm
Switching Times (10% to 90% and 90% to 10%) ( $I_F=20$ mA)	$t_r, t_f$	-	.5	-	$\mu\text{s}$
Capacitance (F=1 MHz)	$C_0$	-	30	-	pF
Forward Voltage ( $I_F=20$ mA)	$V_f$	1.7	1.9	2.1	V

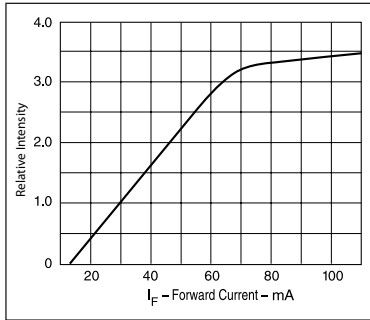

FIGURE 1. Normalized power launched versus forward current.

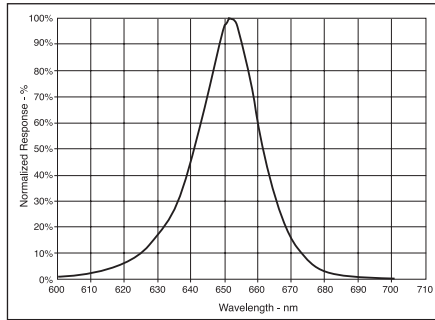

FIGURE 2. Typical spectral output versus wavelength.

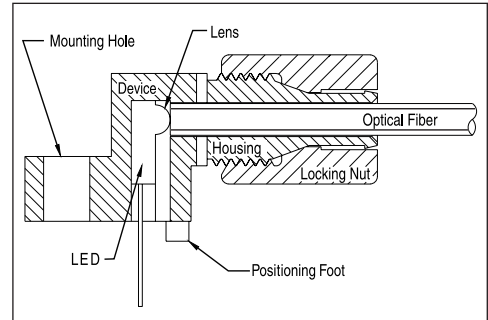

FIGURE 3. Cross-section of fiber optic device.

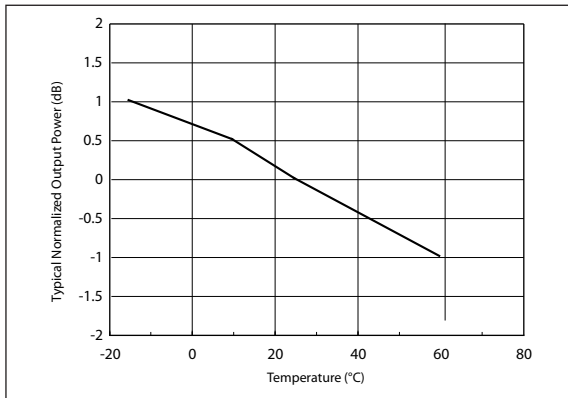

FIGURE 4. Output power versus temperature

## FIBER TERMINATION INSTRUCTIONS

1. Cut off the ends of the optical fiber with a single-edge razor blade or sharp knife. Try to obtain a precise 90-degree angle (square).
2. Insert the fiber through the locking nut and into the connector until the core tip seats against the internal micro-lens.
3. Screw the connector locking nut down to a snug fit, locking the fiber in place.

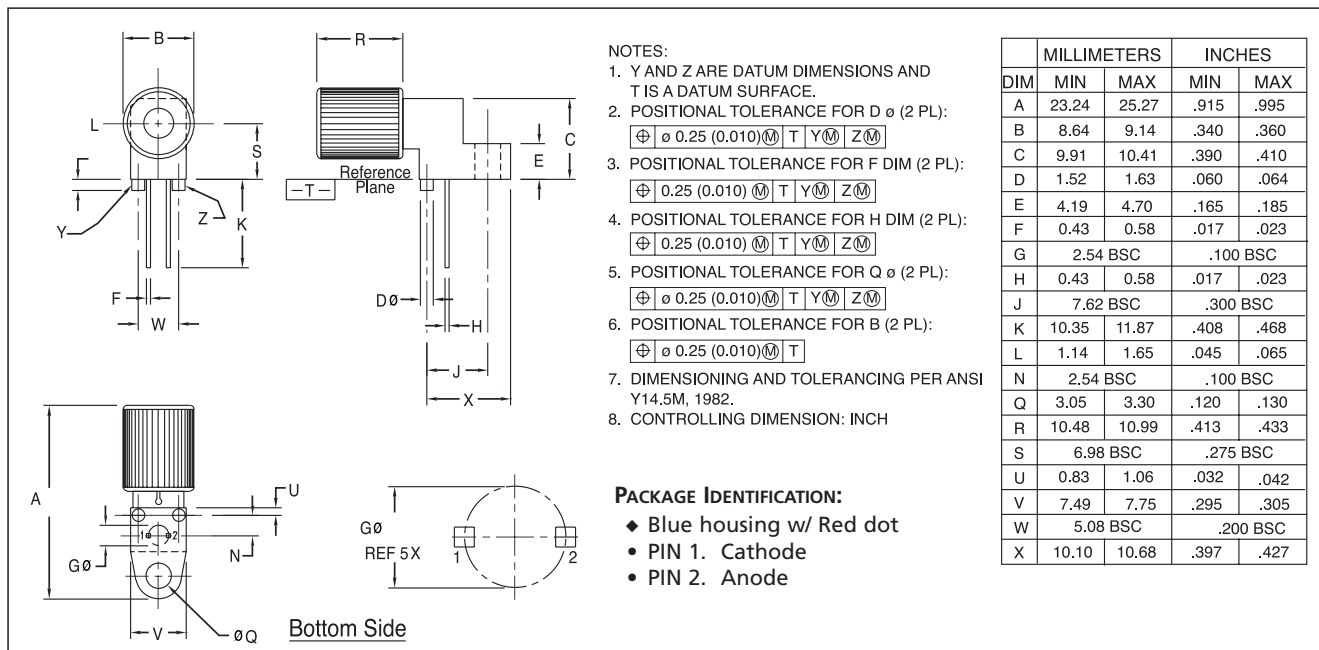

FIGURE 5. Case outline.