



Chipsmall Limited consists of a professional team with an average of over 10 year of expertise in the distribution of electronic components. Based in Hongkong, we have already established firm and mutual-benefit business relationships with customers from,Europe,America and south Asia,supplying obsolete and hard-to-find components to meet their specific needs.

With the principle of “Quality Parts,Customers Priority,Honest Operation,and Considerate Service”,our business mainly focus on the distribution of electronic components. Line cards we deal with include Microchip,ALPS,ROHM,Xilinx,Pulse,ON,Everlight and Freescale. Main products comprise IC,Modules,Potentiometer,IC Socket,Relay,Connector.Our parts cover such applications as commercial,industrial, and automotives areas.

We are looking forward to setting up business relationship with you and hope to provide you with the best service and solution. Let us make a better world for our industry!



## Contact us

Tel: +86-755-8981 8866 Fax: +86-755-8427 6832

Email & Skype: info@chipsmall.com Web: www.chipsmall.com

Address: A1208, Overseas Decoration Building, #122 Zhenhua RD., Futian, Shenzhen, China



The image features a bundle of fiber optic cables that fan out from the bottom right towards the top left. Each individual fiber is illuminated with a bright blue light, creating a starburst effect at the tips. The background is solid black, which makes the glowing blue fibers stand out prominently. The overall aesthetic is high-tech and futuristic.

# OPTICAL VOICE LINK

INDUSTRIAL FIBER OPTICS

# TABLE OF CONTENTS

Preface .....	ii
OBJECTIVE .....	1
STARTING OUT .....	1
TOOLS AND TEST EQUIPMENT .....	1
KIT COMPONENTS .....	2
ASSEMBLY INSTRUCTIONS .....	2
EXPERIMENTS AND ACTIVITIES .....	8
"NUTS AND BOLTS" OF FIBER OPTICS .....	12
EXTENDING THE LINK .....	25
GLOSSARY .....	26
REFERENCES .....	28
RELATED PRODUCTS .....	30

\* \* \*

## Warranty Information

This kit was carefully inspected before leaving the factory. If any components were damaged in shipping, *Industrial Fiber Optics* will replace them at its discretion. Since soldering and incorrect assembly can damage electrical components, no warranty can be made after assembly has begun. If any parts become damaged, replacements may be obtained from most radio/ electronics supply shops. Refer to the parts lists on pages 2 and 5 of this manual for identification.

*Industrial Fiber Optics* recognizes that responsible service to our customers is the basis of our continued operation. We welcome and solicit your feedback about our products and how they might be modified to best suit your needs.

# PREFACE

You have undoubtedly heard about the wonders of fiber optics. AT&T, Sprint and other large telecommunication companies have saturated the airwaves and print media with advertisements heralding this bright new technology. Futurists talk about the marvels of lightwave communications and photonic technology. Omni magazine writes about "Fiberopolis." Long-distance telephone calls travel through optical fiber crossing the United States and spanning the oceans to connect the continents.

The enthusiasm is not mere hype; fiber optic technology is real and important. From coast to coast, phone companies are laying fiber in the ground, pulling cable through manholes and stringing it between poles. The military is buying fiber for portable battlefield communications systems, due to its superior performance. Medical fiber optic systems allow physicians to peer inside the human body without surgery. Very few technologies ever realize the fantastic growth rates predicted for them by market analysts. Fiber optics, however, has exceeded predictions.

As we pass Y2k, fiber optics will become common in your everyday life. It will enter the office environment. In your home, it will provide services that would have been impractical without it: high-definition TV, secondary education classes in the comfort of your home, a paper-less, environmentally clean "newspaper."

A decade ago, fiber optics was tucked away in the back pages of optics books, and optics courses were options for senior-level physics majors. Even today, few universities have full-fledged optics programs, and even fewer have fiber optics programs alone. Most of today's optics specialists were trained in other fields, typically electronics or physics.

But today, you are not alone in your interest in fiber optics. Interest is increasing as technology advances and begins affecting everyone's life.

The *Optical Voice Link* is a project-oriented introduction to optical fiber communications. This booklet contains all the information needed to construct this project including component lists, a section on theory of design and operation, assembly instructions and simple exercises to increase your knowledge. A list of references, fiber optics glossary and additional projects complement the instruction.

Welcome to the fascinating and expanding world of fiber optics. We hope that you will find the field an exciting and interesting one in which to work and play.

# OBJECTIVE

Several objectives can be accomplished with the *Optical Voice Link*: An instructor may use it as a short, hands-on fiber optic curriculum or as a module to demonstrate before the class. A student may use the kit for a science project; hobbyists can use it as a home or industrial project to amaze their friends. Experience and knowledge will be gained during assembly and while working with the electronic microphone, analog fiber optic transmitter and receiver, and the fiber cable interfaces. You will hear your own voice, for example, after it has been converted into light and then coupled into, through and out of an optical fiber.

# STARTING OUT

The *Optical Voice Link* is an introduction to the mysteries and science of fiber optics. No prior fiber optics experience is needed to build this kit and bring it to operational level. After completion, it can be used to demonstrate the unique characteristics of fiber optics or in several practical commercial and industrial applications.

This booklet is your guide to understanding the theory of fiber optic communication, and it includes assembly instructions; please read them carefully to avoid mistakes. Several exercises have also been included to help you understand this technology. If, after completing this kit, you would like to acquire more knowledge about fiber optics, check the **List of References** on pages 28 and 29, and the list of other products we offer, on pages 30 and 31.

The kit you have purchased furnishes all the parts required to construct a fully functional fiber optic voice link. Before beginning the actual assembly, check the contents of each component packet against the lists in **Tables 1** and **2** to ensure you have a complete kit. Alkaline batteries are required, but not included (link may not work properly if you do not use alkaline batteries). The link can be extended up to 10 meters with additional fiber cable and splices purchased separately.

A portion of the instructions suggests the use of an oscilloscope to perform demonstrations and to make some of the measurements. It is helpful but not necessary. You can complete the kit and learn a significant amount about fiber optics without one.

# TOOLS AND TEST EQUIPMENT YOU'LL NEED

Wire cutters

Small Phillips screw driver

1 ml water or light oil

25-watt soldering iron

Two 9-volt alkaline batteries

Single-edge razor blade or sharp knife

Needle-nose pliers

Small adjustable wrench

Rosin-core solder

18-gauge wire-stripper

Dual-trace oscilloscope (optional)

# KIT COMPONENTS

This kit when completed features a transmitter assembly, an inter-connecting fiber optic cable and a receiver assembly. **Table 1** contains the component list for the transmitter portion, and **Table 2** lists the required parts for the receiver portion, including the fiber optic cable and polishing paper.

**Table 1. Transmitter printed wiring board parts list.**

D/N	P/N	Description	Color-code
C1		220 $\mu$ f electrolytic capacitor	
C2		.047 $\mu$ f Mylar <sup>®</sup> capacitor	
D1		Red LED	
D2	IF-E96	Fiber optic red LED	Pink Dot
H1		Battery holder	
H2		2-56 X 1/4 inch long screws (2)	
H3		2-56 X 3/8 inch long screw	
H4		2-56 nuts (3)	
H5		Rubber mounting bumpers (3)	
MIC1		Microphone	
PWB1		Trans. printed wiring board	
R1		2.2 k $\Omega$ 1/4 watt resistor	Red Red Red
R2		2.2 k $\Omega$ 1/4 watt resistor	Red Red Red
R3		150 $\Omega$ 1/4 watt resistor	Brown Green Brown
SW1		Momentary switch	
U1	LM386N	Audio amplifier	

# ASSEMBLY INSTRUCTIONS

**Follow the guidelines below when assembling printed wiring boards:**

- Mount all components on the side of the printed wiring boards with the white lettering. (Component Side.)
- Use the white markings on the printed circuit boards to determine where each part is to be placed.
- All soldering is to be completed on the side opposite components. (Solder side.)
- Use a water-soluble or rosin core solder such as Radio Shack P/ N 64-001. Do not use an acid or caustic flux solder such as used in industrial applications.
- Avoid applying prolonged heat to any part of the board or component, to prevent damage. 5 seconds maximum.
- After soldering each component, trim its lead length flush with the surface of the solder.



Resistor

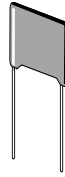

Mylar<sup>®</sup> capacitor

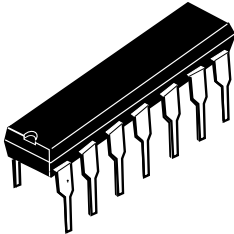

Integrated Circuit

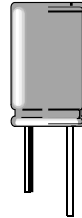

Electrolytic capacitor

**Figure 1. Component identification: resistors, capacitors, ICs.**

## **Transmitter Printed Wiring Board**

1. If the transmitter and receiver printed wiring boards are connected, break them apart along the groove running between them. Set the receiver board aside until you reach the Receiver Assembly section.
2. Insert resistors **R1** through **R3**, one at a time into the printed wiring board and solder them in place.
3. **C1** is sensitive to the direction in which it is installed. Identify the wire marked with minuses ( - - ), the shortest lead, then the round pad on the printed wiring board within the area corresponding to that capacitor. Match up the two, insert the leads properly into the board, and solder the capacitor into place.
4. There is no positive/ negative orientation of capacitor **C2**. Identify, insert its leads through the board and solder them in place. Do not allow solder to touch body of component.
5. Locate the square pad within the area on the printed wiring board designated for placement of **D1** (the red LED). Insert the LED with the shortest leg of **D1** (the cathode) into the respective square pad on the printed wiring board, and solder it into place.
6. Identify pin 1 of **U1** (the lower left pin of the integrated circuit [IC] when viewed from above). Insert the IC into the designated spot marked on the printed circuit board, with pin 1 to your lower left into the hole with the square pad. Solder in place.
7. Insert switch **SW1** on the board and solder it in place.
8. Install the battery holder following the legend outline, fasten in place with two 2-56 × 1/4 inch screws and nuts, and solder the two electrical leads.

9. Clean the printed circuit board with soap and warm water to remove solder residue. Soapy water will not harm the components as long as electrical power is not being applied—in which case you don't want to get anywhere near water anyway, for safety's sake. If you used a rosin core solder, clean the board with the flux remover before washing in soap and water. Rinse thoroughly. Shake the board to remove water from under the IC. Wipe everything dry with paper towels and let air-dry for 30 minutes minimum.
10. The microphone, **MIC1**, is polarity sensitive. Insert it so the part outline aligns with the white legend on the printed wiring board. Solder in place.
11. Identify **D2** as the blue fiber optic housing with a pink dot on one side. Insert **D2** in the designated area on the printed wiring board. Fasten in place with a 2/56 × 3/8 inch screw and nut. Solder the leads.
12. Separate the three rubber bumpers from each other, remove the paper backing that protects the adhesive and install on the solder side of the printed wiring board. Place two on the end by the battery holder and one near the fiber optic LED among all of the protruding leads.
13. Insert a 9-volt alkaline battery (user must provide) into the battery holder.

*(You may notice that some marked portions of the board do not have components laced in them. Don't be alarmed; they are not needed in this kit.)*

## **Receiver Assembly Steps**

1. Insert resistors **R1** and **R3**, one at a time into the receiver printed wiring board and solder.
2. **C1** and **C3** are capacitors which are sensitive to the directions in which they are installed. Identify the wire marked with minuses (- - -), the shortest lead, then the round pad on the printed wiring board within the area corresponding to that capacitor. Match up the two, insert the leads properly into the board, and solder the capacitor into place.
3. There is no positive/ negative orientation of capacitors **C2** and **C4**. Identify each, insert their leads through the board and solder in place.
4. Locate the square pad within the area on the printed wiring board designated for placement of **D1** (the green LED). Insert the shortest leg of **D1** (the cathode) into the respective square pad on the printed wiring board, and solder into place.
5. Identify pin 1 of **U1** (the lower left pin of the integrated circuit [IC] when viewed from above). Insert the IC into the designated spot marked on the printed circuit board, with pin 1 to your lower left into the square hole. Solder in place.



**Table 2. Receiver printed wiring board parts list.**

D/N	P/N	Description	Color-code
<b>C1</b>		220 $\mu$ f electrolytic capacitor	
<b>C2</b>		.047 $\mu$ f Mylar <sup>®</sup> capacitor	
<b>C3</b>		220 $\mu$ f electrolytic capacitor	
<b>C4</b>		.047 $\mu$ f Mylar <sup>®</sup> capacitor	
<b>D1</b>		Green LED	
<b>H1</b>		Battery holder	
<b>H2</b>		2-56 X 1/4 inch long screws (2)	
<b>H3</b>		2-56 X 3/8 inch long screw	
<b>H3</b>		2-56 nuts (3)	
<b>H4</b>		Rubber mounting bumpers (3)	
<b>H5</b>		6 inches speaker wire	
<b>PWB2</b>		Rec. printed wiring board	
<b>Q1</b>	IF-D92	Fiber optic phototransistor	White Dot
<b>R1</b>		2.2 k $\Omega$ 1/4 watt resistor	Red Red Red
<b>R2/SW1</b>		5 k $\Omega$ potentiometer with on/off switch	N/A
<b>R3</b>		10 $\Omega$ 1/4 watt resistor	Brown Black Black
<b>U1</b>	LM386N	Audio amplifier	
<b>SPKR1</b>		3-inch speaker	
<b>F1</b>		3 meters 1000 $\mu$ m plastic fiber	
		600 grit polishing paper	

- Install the battery holder following the legend outline, fasten in place with two 2-56  $\times$  1/4 inch screws and nuts, and solder the two electrical leads.
- Separate the two conductors of the speaker wire about 12 mm (.5 inch) on one end and about 25 mm (1 inch) on the other end. Remove 6 mm (.25 inch) of insulation from both ends of both conductors.
- Locate an area marked "Speaker" on the receiver printed wiring board just ahead of the battery holder. Insert the copper-colored conductor of the speaker wire into the hole marked with a "+" and solder. Insert the other conductor into the other hole and solder it in place.
- Clean the printed circuit board with soap and warm water to remove solder residue. Soapy water will not harm the components as long as electrical power is not being applied—in which case you don't want to get anywhere near water anyway, for safety's sake. If you used a rosin core solder, clean the board with the flux remover before washing in soap and water. Rinse thoroughly. Shake the board to remove water from under the IC. Wipe everything dry with paper towels and let air-dry for 30 minutes.
- Identify **Q1** as the black fiber optic housing with a white dot on one side. Insert **Q1** in the designated area on the printed wiring board. Fasten it in place with a 2-56 inch  $\times$  3/8 screw and nut. Solder the leads.
- Insert the potentiometer, **R2/ SW1**, on the board and solder in place.
- Separate the three rubber bumpers from each other, remove the paper backing that protects the adhesive and install on the solder side of the printed wiring board. Place two on the end by the battery holder and one near the fiber optic phototransistor among all of the protruding leads.



# Fiber Preparation Instructions

Each end of the optical fiber must be carefully prepared so it transmits light effectively.

1. Cut off the ends of the cable with a single-edge razor blade or sharp knife. Try to obtain a precise 90-degree angle (square).
2. Wet the 600 grit polishing paper with water or light oil and place it on a flat, firm surface. Hold the optical fiber upright, at right angles to the paper, and polish the fiber tip with a gentle "figure-8" motion as shown in **Figure 3**. You may get the best results by supporting the upright fiber against some flat object such as a portion of a printed wiring board.

**(Don't insert the fiber ends into the fiber optic LED or photodetector until we give you the word, in the next section.)**

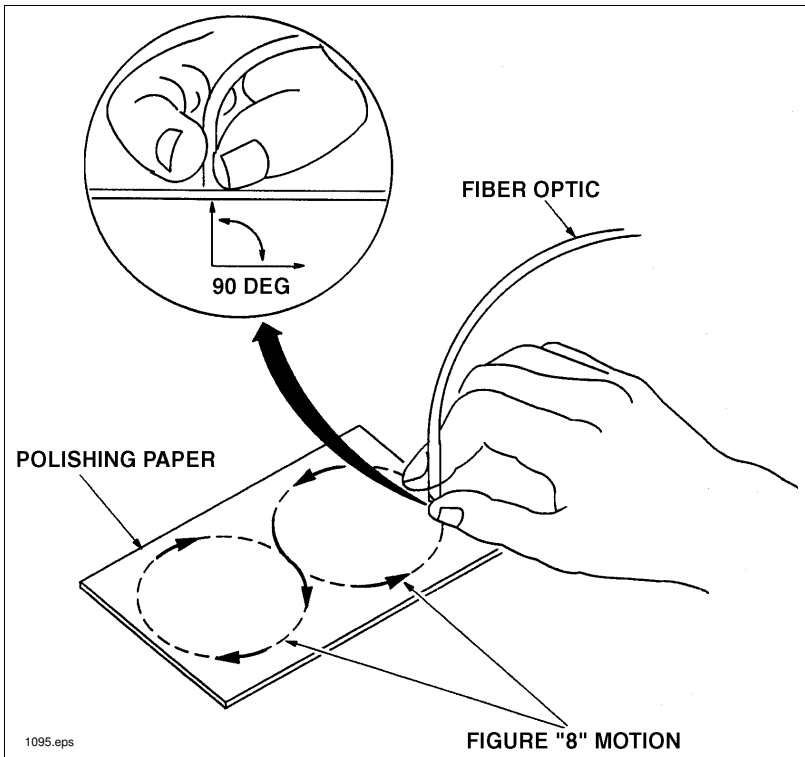

**Figure 3. Pattern and orientation of the optical fiber during polishing.**

# EXPERIMENTS AND ACTIVITIES

- A1.** *Grasp an optical fiber near its tip between your thumb and forefinger. Point it toward a light source and observe the other end of the fiber. Note the changes in brightness in that end as you move the other end around, or cover its tip with a finger. Do any colors of light seem to transmit better than others?*
- A2.** *Holding the fiber about .5 mm (.02 inches) from this page, move it left to right across the heading of this section. What changes do you observe in the brightness at the other end of the fiber?*
- A3.** *Push the momentary switch on the transmitter board to energize this assembly. The red LED (**DI**) should light. If not, check battery condition and assembly of the printed wiring board including installation of **R1** and orientation of **DI**.*
- A3.** *Determine if the transmitter fiber optic LED (**IF-E96**) is on by measuring the voltage across it with a multimeter or oscilloscope when the momentary switch is closed. The proper operating voltage for this LED is approximately 1.8 volts. If the LED does not have any voltage across it, double-check the installation of **UI** and **R2**. (You should be able to see red light being emitted from inside the LED housing when switch is closed.)*
- A4.** *With an oscilloscope, using AC and DC input coupling, vary the sweep setting and observe the voltage at the output of **LM386N** (pin 5, **UI**) for the following sounds: talking, crumpling paper, whistling, humming, blowing a whistle, tapping your finger on the microphone, clapping. Describe or draw below the amplitude and frequency of the signals seen on the oscilloscope display.*

- A5.** *Do you see a periodic signal on the oscilloscope display when humming or whistling? If you change pitch does the period of measured signal on the oscilloscope change?*
- A6.** *In electronics, multiple circuit designs often will achieve the same design goals. We'd now like you to design an electronic LED drive circuit different than the one on the transmitter printed wiring board. A schematic of this transmitter is shown in **Figure 11** (gain of LM386N as shown is 20). We suggest using an operational amplifier and a NPN transistor. Single or dual voltage supply is acceptable. Draw that circuit below.*
- A7.** *Press the momentary switch on the transmitter board and measure the voltage across **R3** with an oscilloscope or multimeter. Calculate the current through the red fiber optic LED (**D2**).*
- A8.** *What is the minimum voltage out of LM386N in the circuit shown in **Figure 11** before the red fiber optic LED would turn off, or become very non-linear? Assume  $V_f$  of the LED is 1.8 volts.*
- A9.** *Assuming that the maximum voltage output from the 9-volt battery is 8.5 volts under load, what is the maximum current that can flow through the red fiber optic LED (**D2**) when being driven by **UI** through **R3**?*

- A10.** Connect the transmitter and receiver assemblies with the optical fiber, following the steps in **Figure 4**. Move the transmitter and receiver printed wiring boards as far apart as the fiber length will allow.

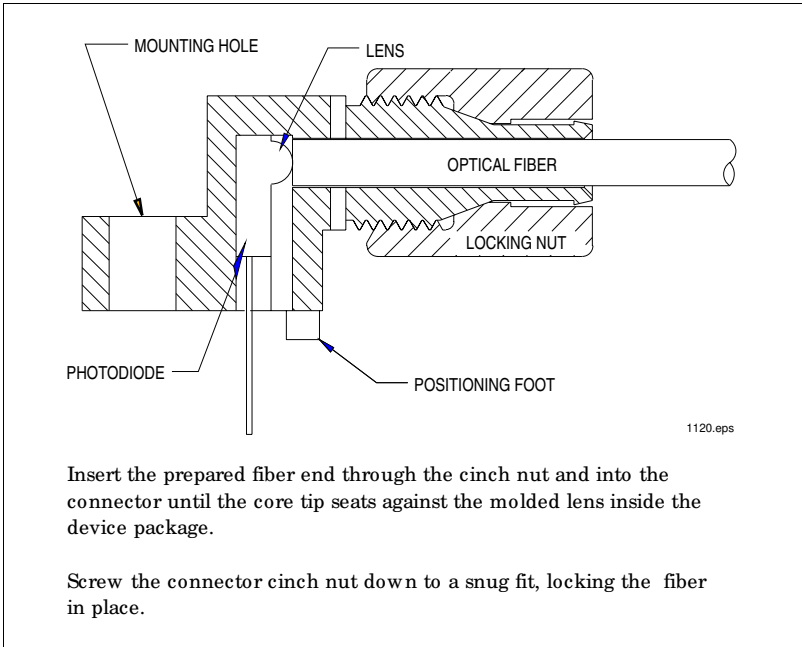

**Figure 4. Cross-section of fiber optic LED and cable.**

- A11.** Turn the receiver switch on and turn it clockwise to about the midway position. Press the momentary switch on the transmitter and speak into the microphone. You should hear your voice from the speaker at the receiver end. (If a high-pitched sound is produced by the receiver when pressing the momentary switch, reduce the volume at the receiver.) In the space below describe the quality of your voice reproduction at the receiver.

- A12.** Using both channels of a dual-trace oscilloscope, look at the signals at the output of **UI** (pin 5) on the transmitter and receiver assemblies. Observe the signals at both points while whistling softly. Describe the signals. Are the two signals in phase? Move closer to the microphone or whistle louder. Can you see signals on the oscilloscope beginning to get distorted? When distortion is visible on the oscilloscope display, what is the quality of sound coming from the receiver?

- A13.** *Assuming that this receiver needs  $2 \times 10^{-6}$  watts of light to reproduce the audio signal, the transmitter launches  $50 \times 10^{-6}$  watts of power into the fiber and the fiber has 1 dB of attenuation per meter, determine the maximum length of cable that can be installed between transmitter and receiver and still function properly.*
- A14.** *With the transmitter and receiver assemblies as far apart as possible, adjust the gain of the receiver to as high as possible without the receiver producing a high-pitched squeal when the transmitter momentary-switch is closed. Have somebody touch the transmitter microphone to a mechanical clock while holding down the momentary switch. (If you are completing this project by yourself, you may solder a jumper wire across the momentary switch connections.) Can you hear the gears inside the clock moving, through the receiver speaker? Repeat this experiment with an electric clock.*
- A15.** *Disconnect the fiber from the transmitter, leaving the fiber connected to the receiver. Turn the volume on the receiver switch to maximum. Hold the transmitter end of the fiber up to a fluorescent light. What do you hear? The noise you hear is 120 Hz, twice the frequency of the 110-volt, 60 Hz AC input. The fluorescent light is pulsing; it is not actually "on" all the time. Repeat this procedure, holding the fiber close to an incandescent light bulb. What do you hear now? Describe the difference.*
- A16.** *What is the numerical value for the current through the fiber optic LED in terms of millivolts of input voltage to LM386N? (Answer is in mA/mV.) What is the numerical value of the voltage output to the speaker in terms of milliwatts of optical power on the base of Q1? Assume the responsivity of Q1 to be 100 mA/mW.*

# "NUTS AND BOLTS" OF FIBER OPTICS

Before fiber optics came along, the primary means of real-time, reliable data communication was electrical in nature. It was accomplished using copper wire or by transmitting electromagnetic (radio) waves through free space. Fiber optics changed that by providing an alternate means of sending information over significant distances — using light energy. Although initially a very controversial technology, fiber optics has today been shown to be very reliable and cost-effective.

Light, as utilized for communications, has a major advantage because it can be manipulated (modulated) at significantly higher frequencies than electrical signals. For example, a fiber optic cable can carry up to 100 million times more information than a telephone line! The fiber optic cable has lower energy loss and wider bandwidth capabilities than copper wire.

As you will learn, fiber optic communication is a quite simple technology, and utilizing electronic technology to a large extent. In fact, it was research in electronics that established the groundwork for fiber optics to develop into the communications giant that it is today. Fiber optics became reality when several technologies came together at once. It was not an immediate process, nor was it easy, but it was most impressive when it occurred. An example of one critical product which emerged from that technological merger was the semiconductor LED, of the type used in the educational kit which you have constructed. The following sections provide more detail about the electronics nature of a basic fiber optic data link, and the theory of operation for your *Industrial Fiber Optics* kit.

## Advantages of Fiber Optics

Fiber optics has at least eight advantages over conventional copper cables:

- Greater information-carrying capabilities
- Smaller cable diameter
- Lighter weight-per-cable length
- Greater transmission distance
- Immunity to electrical interference
- Cables do not radiate energy
- Greater reliability
- Lower overall cost



# Elements of a Fiber Optic Data Link

Basically, a fiber optic data link contains three main elements: a transmitter, an optical fiber and a receiver. The transmitter takes data previously in electrical form and transforms it into optical (light) energy containing the same information. The optical fiber is the medium which carries the energy to the destination (receiver). At the receiver, light is converted back into electrical form with the same pattern as originally fed to the transmitter by the person who sent the message.

It is important to note that optical energy can be beamed through the air or free space (like a flashlight beam). In fact, there are applications in which communication through air is used when installing optical fiber would be too costly or impractical. The advantages of optical fiber are that it allows light to be routed around corners and transported through obstructions (such as walls in buildings), just as household electrical and telephone wiring do, but with much greater signal-carrying capacity, plus being able to operate at greater distances and on foggy and rainy days.

Also contained in fiber optic data links are connectors that provide the connections among transmitter and receiver modules and optical fiber. These allow quick addition or removal of modules, and the ability to offer communication capabilities at multiple locations using various "coupling" and "splitting" devices.

The educational kit you have constructed contains all the elements described above with the exception of multiple distribution devices, since it links a single receiver and transmitter. The transmitter and receiver circuits in this kit are analog. This means the sound waves are converted to light to transmit down the fiber and then converted back electrical and acoustic waves at the receiver. We will not digitize the audio sounds and recreate them at the receiver as is done in telephone fiber optic networks.

## Light: A Review

The operation of an optical fiber depends on the basic principles of optics and the interaction of light with matter. The first step in understanding fiber optics is to review some of the properties of light.

### Wavelength and Particles

Many of light's properties are explained by thinking of light as an electromagnetic wave. "Light" is a small part of the electromagnetic spectrum as can be seen in **Figure 5**. The relationship between light's wavelength and frequency can be seen by **Equation 1**:

$$\lambda = \frac{c}{f} \qquad \text{Eq. 1}$$

where  $c$  is the speed of light and  $f$  is frequency.

Light is higher in frequency and shorter in wavelength than the more common AM and FM radio waves. Visible light ranges from 380 nanometers, (nm), as far deep violet, to 750 nm, as far deep red. Infrared radiation has longer waves than visible light. Most fiber optic systems operate using infrared light with wavelengths between 750 and 1500 nm.

Light also has some particle-like properties similar to electrons (atomic). A light particle is called a photon, a discrete unit of energy, but it has no mass. The amount of energy contained by a photon depends on its frequency. The higher the frequency, the higher the energy. The energy,  $E$ , in joules, contained by a photon is:

$$E = h \cdot f \tag{Eq. 2}$$

where  $f$  is frequency in Hz and  $h$  is Planck's constant, which is  $6.63 \times 10^{-34}$  joule-seconds.

Light's ability to act sometimes as a wave and sometimes as a particle, prompted the famous "wave-particle duality" theory of modern physics. Using both of light's properties is important in fiber optics. For example, many properties of optical fiber vary with wavelength, so the wave description is used. The responsivity of optical detectors is best explained by light's particle theory.

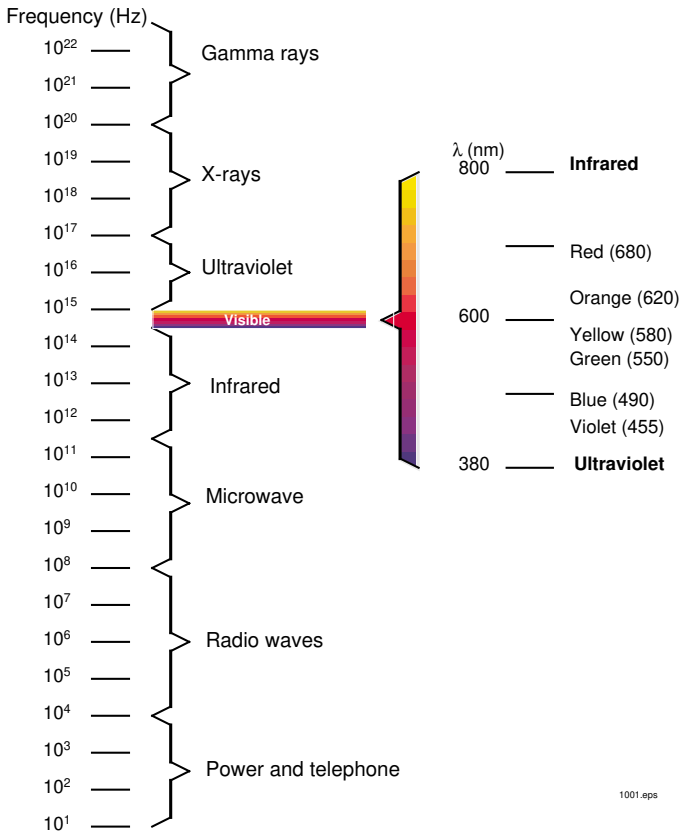

Figure 5. The electromagnetic spectrum.

## Refractive Index

The most important optical measurement for any optical material is its refractive index ( $n$ ). Refractive index is the ratio of the speed of light in a vacuum to the speed of light in a material.

$$n = \frac{C_{\text{vacuum}}}{C_{\text{material}}} \quad \text{Eq. 3}$$

The speed of light through any material is always slower than in a vacuum, so the refractive index is always greater than one. In practice, the refractive index is measured by comparing the speed of light in the material to that in air, rather than in a vacuum. This simplifies the measurements and in most cases does not make any practical difference, since the refractive index of air is very close to that of a vacuum. See **Table 3**.

## Why Optical Fiber Works As It Does

Light travels in straight lines through most optical materials, but that's not the case at the junction (interface) of two materials with different refractive indices. Air and water are a case in point, as shown in **Figure 6**. The light ray traveling through air actually is bent as it enters the water. The amount of bending depends on the refractive indices of the two materials involved, and also on the angle of the incoming (incident) ray of light as it strikes the interface. The angle of the incident ray is measured from a line drawn perpendicular to the surface. The same is true for the angle of the refracted ray of light after it has been bent.

The mathematical relationship between the incident ray and the refracted ray is explained by **Snell's Law**:

$$n_1 \cdot \sin \Theta_1 = n_2 \cdot \sin \Theta_2 \quad \text{Eq. 4}$$

in which  $n_1$  and  $n_2$  are the refractive indices of the initial and secondary materials, respectively, and  $\Theta_1$  and  $\Theta_2$  are the incident and refracted angles.

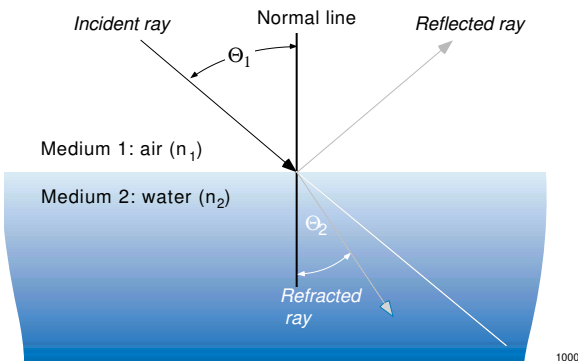

**Figure 6.** The different portions of a light ray at a material interface.

Snell's equation can be rearranged to determine the refracted angle,  $\Theta_2$ , knowing  $n_1$ ,  $n_2$ , and  $\Theta_1$ .

$$\Theta_2 = \text{arc sin} \left( \frac{n_1}{n_2} \bullet \sin \Theta_1 \right) \quad \text{Eq. 5}$$

When  $n_1$  is larger than  $n_2$  there are angles of incidence in which

$$\frac{n_1}{n_2} \bullet \sin \Theta_1 \geq 1 \quad \text{Eq. 6}$$

In this case the incident light ray,  $\Theta_1$ , does not exit and 100 percent of light is reflected at an angle equal to the angle of incidence as if the boundary of  $n_1$  and  $n_2$  were a mirror. (Recall from trigonometry that the maximum value of the sine of any angle is 1.) The phenomenon just described is called *total internal reflection*. The angle at which this total internal reflection occurs is

$$\Theta_{\text{critical}} = \text{arc sin} \frac{n_2}{n_1} \quad \text{Eq. 7}$$

The concept above, which has been discussed in one dimension, can be further expanded into two dimensions which would then have the capability of channeling or directing light from one point to another. The most common two-dimensional structure to achieve is a solid rod of material surrounded by a layer of lower-refractive-index material. This two-dimensional structure is the fundamental construction of all optical fibers. The total internal reflection property (where the outer layer has a lower refractive index than the core) is a critical element of the principal theory for light transmission in all optical fibers. If you'd like to learn more about the mathematics governing fiber optics, we recommend that you consult the books listed in the **References** section. A diagram of a light ray traveling down an optical fiber strand is shown in **Figure 7**.

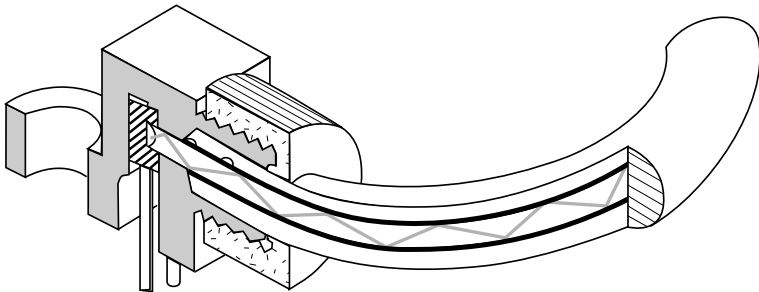

**Figure 7. A light ray traveling through and trapped by total internal reflection inside an optical fiber.**

**Table 3. Refractive indices of some common materials.**

Material	Refractive Index
Vacuum	1.0
Air	1.00029
Water	1.33
Fused quartz	1.46
Glass	1.45 - 1.6
Silicon	3.4
Diamond	2.0
Gallium arsenide	3.6

## Numerical Aperture

The critical angle of an optical fiber although critical to understanding how a fiber operates is not a normally specified parameter. Acceptance angle and numerical aperture are the common specifications and are related to the critical angle. Numerical aperture of an optical fiber can be calculated from the core's and cladding's refractive indices.

$$NA = \sqrt{n_{core}^2 - n_{cladding}^2} \quad \text{Eq. 8}$$

Acceptance angle can be determined by the following equation:

$$\Theta_{acceptance} = 2 \bullet \text{arc sin} \sqrt{n_{core}^2 - n_{cladding}^2} \quad \text{Eq. 9}$$

Acceptance angle of a fiber is the half cone angle of the light that can be launched into an optical fiber and be reflected internally as shown in **Figure 8**. A fiber's numerical apertures or acceptance angles are used to determine collection efficiency from LEDs and photodetectors.

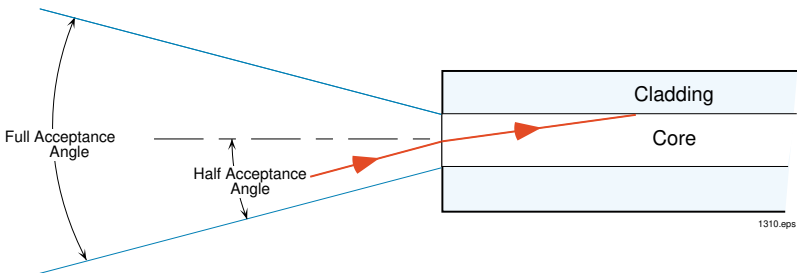

**Figure 8. Optical fiber showing the acceptance angle of light.**

## Fiber Materials

Optical fiber is made from three types of materials:

- Glass
- Plastic
- Other

More than 99 percent of all optical fiber used for data communications in the world is made from glass or plastic. The category "other" includes exotic optical materials such as silicon or gallium arsenide, which are used for special ultraviolet or infrared light applications.

Glass has superior optical qualities compared to plastic, but is more expensive per unit volume, harder to cut and requires special end connections. Glass fiber is typically used for high-data-rate/ long-distance transmission and for medical applications because it can be autoclaved and is impervious to body fluids. For lower data rates and distances less than 150 meters, plastic fibers are more economical, easy to terminate and do not require special tools. A very small amount of fiber is a hybrid solution — plastic-cladding glass. The fiber core is high quality glass, with an inexpensive plastic cladding.

## Attenuation

Throughout this manual we have praised the capabilities of fiber optics. Although fiber has many advantages it is not perfect because a certain amount of light is lost as it travels through the optical fiber. This loss is called *attenuation*, and it has several causes:

- absorption by the material through which light travels
- scattering of light out of the fiber core by imperfections in the fiber
- leakage of light from the core caused by environmental factors such as moisture

Fiber attenuation is measured by comparing output power with input power. Attenuation of a fiber is most often described in decibels (dB). The decibel is a logarithmic unit, relating the ratio of output power to input power. Loss in decibels is defined as:

$$Loss = 10 \bullet \text{Log}_{10} \frac{P_o}{P_i} \qquad \text{Eq. 10}$$

If the output power from a fiber is 0.001 of the input power, the signal has experienced a 30 dB loss. (The minus sign has been dropped for convenience and is implied on all attenuation measurements.)

A fiber's attenuation is very dependent upon the composition of its core material and the wavelength of light being transmitted, as can be seen in **Figure 9**. A fiber's attenuation is normalized for a unit length, usually in kilometers. This normalized definition is called a fiber's characteristic attenuation and is accurate for the measured wavelength only.

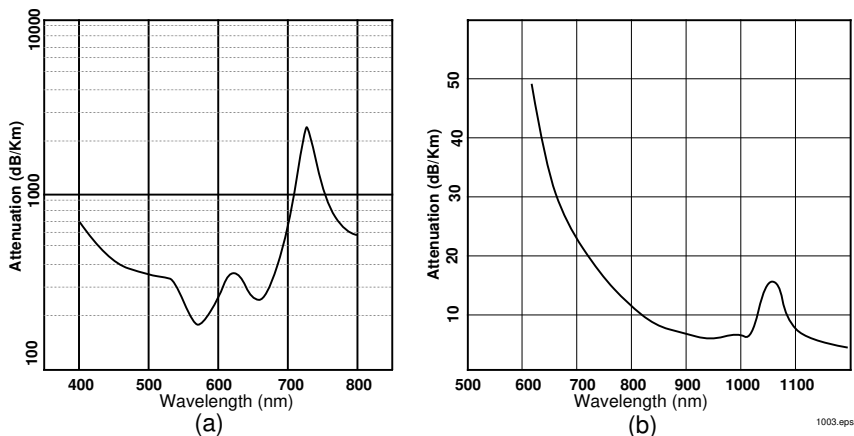

**Figure 9. Attenuation of plastic fiber (a), glass fiber (b).**

## Fiber Construction

The simplest optical fiber cable consists of two concentric layers of transparent materials. The inner portion (the core) transports the light. The outer covering (the cladding) must have a lower refractive index than the core, so the two are made of different materials. Most optical fibers are packaged in a cable with additional layers to protect the core and cladding from environment and mechanical damage or degradation before use, since any damage degrades the optical waveguide as shown in **Figure 10**. Common additional layers found in a fiber optic cable include:

**Buffer** - A protective layer around the cladding to protect it from damage. It also serves as the load-bearing member for the optical cable.

**Strength Member** - Material that is added to the cable to increase tensile strength. Common strengthening materials are Kevlar<sup>®</sup>, steel and fiberglass strands or rods.

**Jacket** - The outermost coating of the cable, which provides protection from abrasion, acids, oil, water, etc. The choice of jacket depends upon the type of protection desired. The jacket may contain multiple layers.

The fiber optic cable in this kit has a polyethylene jacket to protect the polymethyl methacrylate polymer (PMMA) core and fluorine polymer cladding. The fiber core is 980  $\mu\text{m}$  (0.04 inches) in diameter, surrounded by 10  $\mu\text{m}$  of cladding.

## **Transmitter**

Fiber optic transmitters are typically composed of a buffer, driver, and optical source. Often, optical connectors are also integrated into the final package. The buffer electronics provide both an electrical connection and "isolation" between the driver electronics and the electrical system supplying the data. The driver electronics provide electrical power to the optical source in a fashion that duplicates the pattern of data being fed to the

transmitter. Finally, the optical source (LED in this kit) converts the electrical power to light energy with the same pattern.

The following discussion assumes the reader has a basic knowledge of analog circuit functions (e.g., amplifiers, AC-coupling, DC bias) and vocabulary.

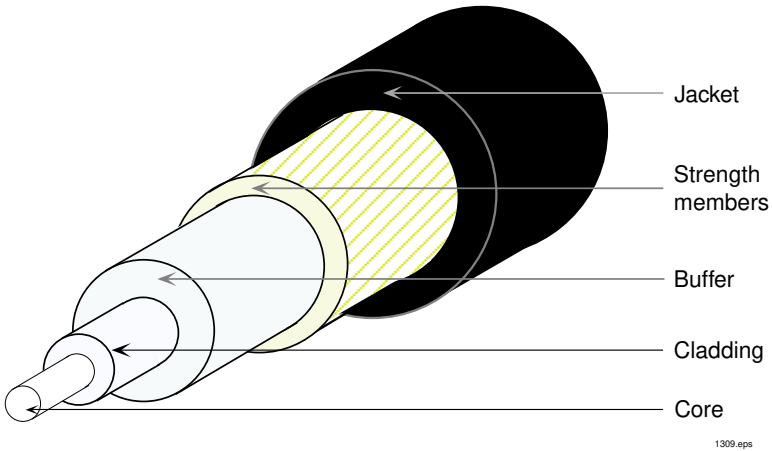

**Figure 10. Cross-section of a simple fiber optic cable.**

## Circuit Operation

As mentioned previously most fiber optic transmitters typically have an amplifier or buffer, driver, optical source, and sometimes an optical connector or interface. The transmitter in this kit also has an acoustic microphone for converting sound waves to an electrical signal, and requires a nine-volt battery with holder to provide electrical power. **Figure 11** shows the schematic of the circuits contained on the transmitter printed wiring board of this kit.

Pushing the momentary-close switch, **SW1**, activates the optical voice link by applying 9-volt battery power to the indicator light, microphone, audio circuits and fiber optic LED. The switch must be closed for the transmitter to operate by generating light to carry audio signals.

Tracing a signal through the transmitter circuit starts with the microphone. Here any acoustic vibrations near the microphone are sensed and produce an electrical AC signal proportional in strength and frequency to that of the acoustic signal. This AC signal is coupled through the DC blocking capacitor (**C2**) to the LM386N audio amplifier. The LM386N amplifies the signal and drives the fiber optic LED (**D2**). The output of the LED is red light with a DC component and AC signal superimposed upon it from the LM386. A typical output signal from LM386N is shown in **Figure 12**.



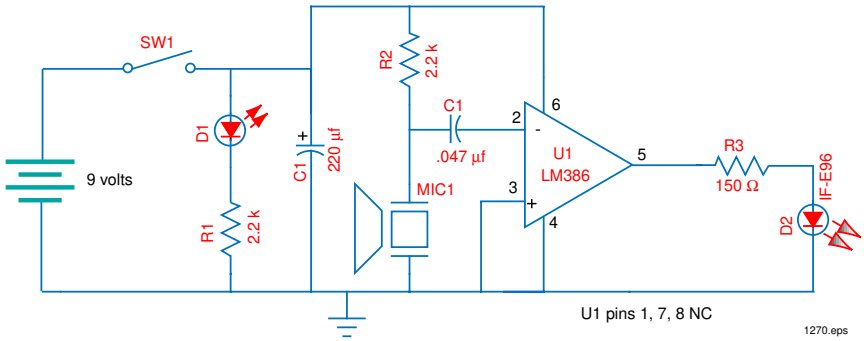

**Figure 11. Transmitter circuit schematic.**

### Microphone

Your voice produces acoustic vibrations, which are picked up by a microphone (MIC1) containing a sensitive membrane and a FET (Field effect transistor). The microphone and R2 form a voltage divider. With no voice input, the microphone acts as a passive resistor, resulting in a voltage across the microphone of about eight volts. When sound is sensed by the microphone, its resistance (and voltage across it) will vary according to the loudness and the frequency.

### Amplifier/Driver

The LM386 is a power audio amplifier designed for use in low-voltage consumer applications. It has an input impedance (pin 2) of 50 K ohms. This input impedance combined with the 0.047 µf capacitor (C2) produces a 3 dB high-pass-frequency point of 70 Hz for the microphone signals. The gain of the LM386N as shown in the circuit schematic is 20. Inputs to the amplifier are ground referenced and the output is internally automatically biased at one-half the supply voltage. The output of LM386N being at one half supply voltage causes a DC current to flow through the red fiber optic LED is equal to

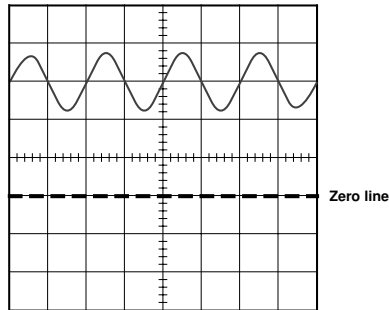

**Figure 12. Oscilloscope display showing a typical AC signal superimposed on a DC level from pin 5 of LM386N in the transmitter circuit.**

$$I_{LED} = \frac{V_{cc}/2 - V_{LED}}{R3}$$

$$V_{cc} - 9 \text{ volts}$$

$$V_{LED} - 1.5 \text{ volts}$$

**Eq. 11**

## LED

The LED, IF-E96, used in this kit produces red Light. Its optical output is centered at 660 nanometers (nm). The IF-E96 fiber optic component also has a built-in connector/ fiber-termination optimized for the jacketed 980  $\mu\text{m}$  core plastic fiber. LEDs are useful for fiber optics because they are inexpensive, reliable, easy to operate, have a wide temperature operating range, and respond quickly to electrical current.

## Miscellaneous parts

Power for the transmitter circuit is provided by a standard 9-volt alkaline battery. Power is activated when the momentary switch (**SW1**) is pressed and held. No power is consumed by the circuit when the switch is open. Typical current consumption from the battery for this circuit when the momentary switch is closed is 25 mA. Because this transmitter operates only momentarily, a battery can last for weeks of use.

A red LED (**D1**) and limiting resistor (**R1**) provide an indication of the transmitter's battery condition, and they function as a "switch-on" indicator. The LED will turn on immediately with the momentary switch's closure. If it is dim or dims after a few seconds of operation, you should replace the battery to ensure best operation.

**C1** functions as a power filter capacitor for the receiver circuit when the **LM386N** amplifier/ driver requires a low impedance source of energy to drive the LED.

## Receiver

Once light energy from the fiber optic transmitter reaches the destination (receiver) it must be converted back to a form of electrical energy with the same information pattern that was fed to the transmitter by the person sending the message. Analog fiber optic receivers typically perform these functions using three elements: a photodetector, an amplifier and sometimes a buffer. As with fiber optic transmitters, the optical connector is often integrated into the receiver package. The photodetector converts light energy (optical power) to an electrical current. Any pattern or modulation imparted in the optical power (from, for instance, a fiber optic transmitter) will be reproduced as an electric current with the same pattern. Long lengths of fibers and other distribution losses can reduce the optical power, resulting in a comparatively weak electrical signal from the photodetector. To compensate for this decline in signal strength, the amplifier increases the amplitude of the electrical signal. Finally, buffer electronics isolate the photodetector and amplifier from any load the receiver is required to drive.