



Chipsmall Limited consists of a professional team with an average of over 10 year of expertise in the distribution of electronic components. Based in Hongkong, we have already established firm and mutual-benefit business relationships with customers from,Europe,America and south Asia,supplying obsolete and hard-to-find components to meet their specific needs.

With the principle of “Quality Parts,Customers Priority,Honest Operation,and Considerate Service”,our business mainly focus on the distribution of electronic components. Line cards we deal with include Microchip,ALPS,ROHM,Xilinx,Pulse,ON,Everlight and Freescale. Main products comprise IC,Modules,Potentiometer,IC Socket,Relay,Connector.Our parts cover such applications as commercial,industrial, and automotives areas.

We are looking forward to setting up business relationship with you and hope to provide you with the best service and solution. Let us make a better world for our industry!



## Contact us

Tel: +86-755-8981 8866 Fax: +86-755-8427 6832

Email & Skype: info@chipsmall.com Web: www.chipsmall.com

Address: A1208, Overseas Decoration Building, #122 Zhenhua RD., Futian, Shenzhen, China



# Fiber Optic Speed of Light Apparatus

Instruction Manual

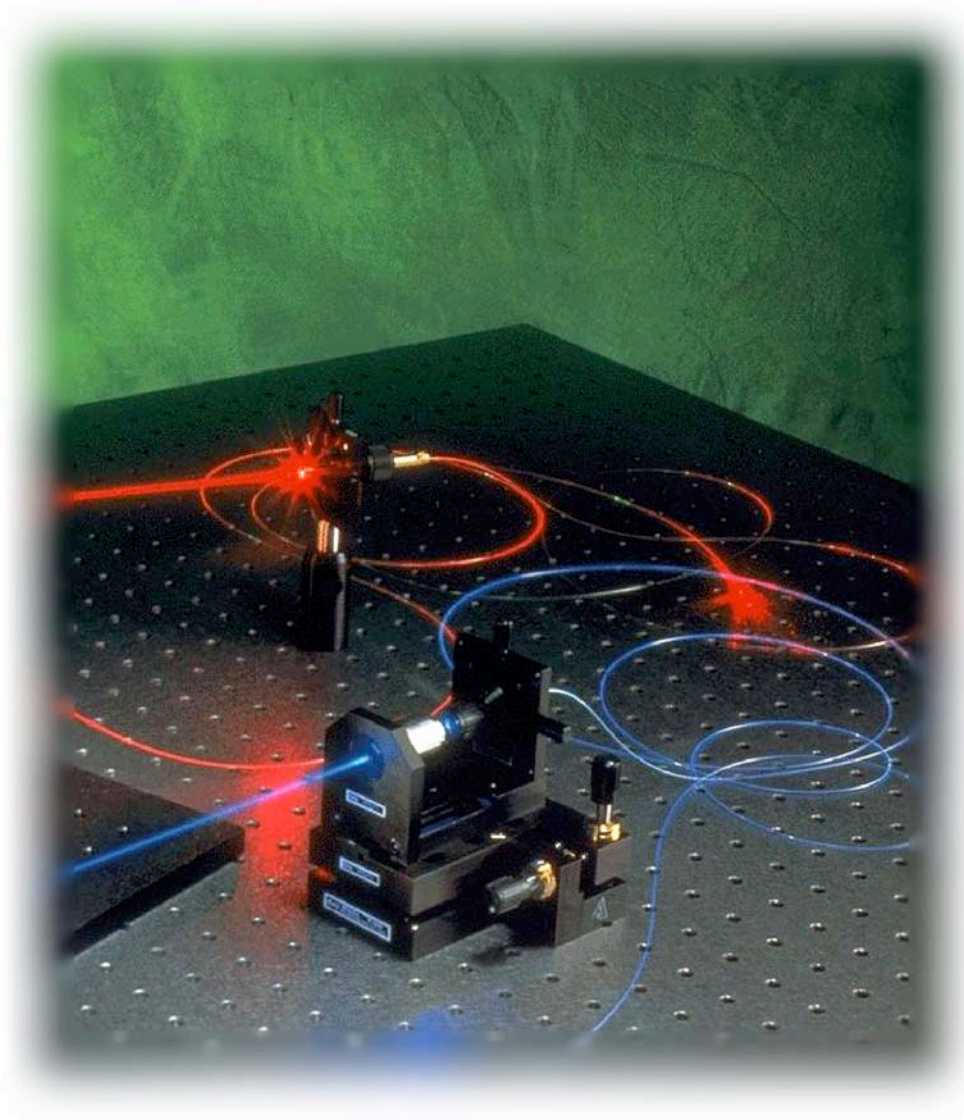

INDUSTRIAL FIBER OPTICS

---

\*

Copyright © 2010  
Previous Printings 2001, 2004  
by Industrial Fiber Optics, Inc.  
12 0225 IF-SL Rev G

Printed in the United States of America

\* \* \*

All rights reserved. No part of this publication may be reproduced, stored  
in a retrieval system, or transmitted in any form or by any means  
(electronic, mechanical, photocopying, recording, or otherwise) without  
prior written permission from Industrial Fiber Optics, Inc.

\* \* \* \* \*

**INDUSTRIAL FIBER OPTICS**  
1725 West 1<sup>st</sup> Street  
Tempe, AZ 85281-7622  
USA

# TABLE OF CONTENTS

INTRODUCTION .....	1
BACKGROUND INFORMATION .....	2
THE SPEED OF LIGHT – A CENTURIES-LONG QUEST .....	2
SPEED ZONES OCCUR WHEN LIGHT MEETS MATTER.....	3
FIBER OPTICS: LIGHT MEETS ITS MASTER AT LAST .....	4
OPTICAL FIBER: THE WORKHORSE TODAY .....	5
THERE IS <u>ALWAYS</u> A NEW FRONTIER .....	7
ACTIVITY .....	8
MATERIALS REQUIRED FOR THE PROJECT .....	8
EQUIPMENT SETUP .....	9
CALIBRATION.....	10
MEASUREMENT.....	11
SPEED OF LIGHT CALCULATION .....	11
APPENDIX.....	13
KIT ASSEMBLY.....	13
FIBER PREPARATION .....	19
REFERENCES .....	20
GLOSSARY .....	22

# INTRODUCTION

---

Welcome to the fascinating world of fiber optics technology! We believe you will find the instructions and exercises in this science curriculum not only educational, but challenging and enjoyable as well.

This manual is an essential component of the *Speed of Light Apparatus* — which is designed for use in science, physics, industrial technology and vocational education classrooms, grades 10-12. Physics fans and other science-oriented individuals (including those who are just intellectually curious about how things work!) may also obtain the apparatus for studies in home or workshop.

Your particular apparatus may have been purchased either fully assembled at our factory, or in kit form which you can assemble on your own. Easy-to-follow instructions for this kit are contained in the *Assembly* portion of this manual.

The manual is intended to guide both instructors and students through a basic introduction to the principles of fiber optics and the measurement of the speed of light. The apparatus includes one experiment, along with descriptions of components, a glossary of terms commonly encountered in fiber optics, and a list of optional reading references which discuss fiber optics theory and development.

Everything is here for you to get in on the ground floor of fiber optics, to develop an understanding of emerging technology in this vast new field of potential applications, and to ready yourself for more advanced studies.

When you are ready to move on to more sophisticated discussions, look for our other study materials and kits specifically designed to make learning both fun and rewarding.

# BACKGROUND INFORMATION

---

The miracles of modern-day fiber optic technology didn't simply show up on someone's door step. Centuries of curiosity, experimentation, frustration and perspiration passed before pure science won out over superstition and guesswork. A small Italian gentleman was among the first to seek enlightenment about the speed of light . . . .

## The Speed of Light – A Centuries-Long Quest

Scientists, and probably even more casual thinkers, began speculating about the speed of light centuries ago. When you consider that early civilizations often made gods and goddesses out of suns, planets and moons, it isn't hard to understand their fascination and wonder about one of the most powerful forms of energy in their world.

One of the first, that we know of, to ask himself, "Hmmm....wonder how fast that stuff travels?" was Galileo Galilei (1564-1642), Italian astronomer and physicist....the same fellow who dropped objects off the now-Leaning Tower of Pisa trying to calculate their rates of fall.

Galileo scored with the tower business, in calculating the fall rates of items as varied as feathers and cannonballs. Light was another matter, however, and he knew he had to attempt his measurements of light speed over a much greater distance if he hoped to get a *whatever*-per-second grip on that speeding luminous energy.

He decided that hilltop-to-hilltop was a good starting point, and that's where he began, with himself on one hill and his trusty assistant on another, well after the sun had set. Each man carried an oil-burning lamp with a cover, so he could shield the light until needed.

Galileo uncovered his lamp briefly, sending a flash of light over to his assistant. The assistant replied, with his own quick flash of light back to the boss. The exchanges continued that night, and many nights more, from hilltops increasingly further apart.

Galileo had hoped to measure the time which elapsed from the moment the lamp shields were uncovered until the light was perceived by his eye. Rotten luck. He finally decided (rightfully) that he and his assistant weren't physically up to the challenge of grappling with an item we now know to travel at 186,000 miles per second. (Incorrectly) he determined that light travels at infinite speed.



**Figure 1. Galileo Galilei (1564-1642).**

The next recorded method of measuring light was that of Frenchman Armande H. L. Fizeau (1819-1896) in 1849. Try to visualize his elaborate, apparently unwieldy array of mirrors, lenses, and a huge rotating cogwheel with 720 teeth, designed to measure the speed of light over a distance of 5.39, count 'em, miles.

But the thing worked. Pretty much. Fizeau and his apparatus computed light speed at 194,000 miles per second. Not bad, when you consider the scientific tools available at that time, plus the difficulty of the experiment.

In the years that followed, investigators steadily improved on Fizeau's equipment and methods of observation. Most notable was the work of American physicist, Albert Michelson, (1852-1931) who replaced Fizeau's 720-tooth wheel with an eight-sided mirror. (He also increased the measurement distance to 44 miles.)

In 1926, Michelson got a grip on light, computed at 299,796 kilometers per second — or 186,284 miles per second.

The quest for precision, and the continued refinement of the measurement, continued until, today, really only hard-core mathematicians quibble about the number of decimal places we should assign to the speed of light.

The speed of light in a vacuum is now listed as 299,792.4562 kilometers per second. For the purposes of everyday discussion we generally suffice with a figure of 300 million meters per second, or 186,000 miles per second.

## Speed Zones Occur When Light Meets Matter

Up to this point, we've talked primarily about light traveling through a vacuum, such as outer space. When light passes through some medium other than a vacuum (such as a gas, solid, or liquid), it slows down. But often not by much.

- At sea level, light speed through air is only about 70 kilometers less per second than it is in a vacuum. (At higher altitudes, where the air is less dense, and where light is impeded less by solid airborne particles, light speed increases.) For most practical purposes we can rate light speed in air versus light speed in a vacuum the same.
- In water, however, things get relatively sluggish. The speed of light is about 25 percent less than in a vacuum.
- In glass, light has even a tougher time. Its speed drops by about 33 percent, compared to its rate in a vacuum.

To put these relationships into some form of mathematical perspective we utilize the term "refractive index" (or "index of refraction") — which refers to the ratio between the speed of light in a vacuum and its speed in some other medium. Here's the equation:

$$\frac{\textit{Light speed in a vacuum}}{\textit{Light speed in another medium}} = \textit{Refractive index}$$

Or, massaging things down into more manageable symbols:

$$\frac{c}{v} = n$$

Substituting the numerical values of light speed in air, water, and glass we would obtain the following refractive indices:

*For air:*  $n = 1.000$   
*For water:*  $n = 1.333$   
*For glass:*  $n = 1.50$

If we went to five decimal places instead of three, we would find the refractive index for air is actually 1.00029.

Precise? Definitely much more so than in the days of Fizeau, not to mention Galileo. You'll soon learn how we can measure the speed of light with accuracy that would have astounded those well-intentioned gentlemen with their lamps, cogwheels, and mirrors.

## Fiber Optics: Light Meets its Master at Last

The modern-day technology of fiber optics got its start back in the days when tinkerers and scientists were trying their best to bend light around corners. It isn't exactly clear why anyone would want to do that, but a lot of people, even a hundred years ago, were unwilling to accept that light travel was confined to straight lines.

They tried hundreds of schemes — many involving intricate arrangements of mirrors — but no one scored big until 1870 when English physicist, John Tyndall (1820-1893), demonstrated a most impressive principle to members of the British Royal Society.

With a simple apparatus whose major components included a light source, a slender stream of falling water, and a bucket, Tyndall demonstrated that light could be guided inside a most definitely un-straight arc of water. His equipment is represented in **Figure 2**.

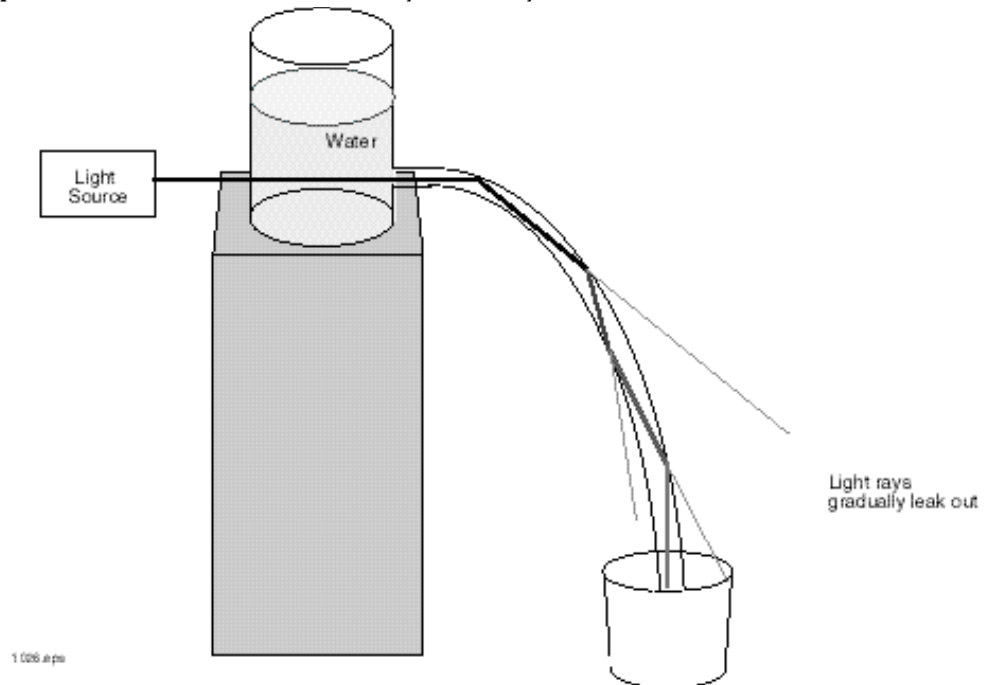

**Figure 2. John Tyndall's demonstration: Guiding light in water.**



Good show! Good show! Tyndall depicted for the first time what now occurs millions of times a day in our high-tech communications industry: Light is **guided** inside some curving medium, and very little is allowed to escape until we're ready to let it go. He used a stream of water. We use slender fibers of glass and plastic.

Sixty-five years after Tyndall's water, light, and bucket demo, Norman R. French, a scientist with American Telephone and Telegraph (AT&T), conceived of and demonstrated the use of light-guiding fibers as a communications device. Proof of the pudding: He was granted a patent for an "optical telephone system" which transmitted voice signals on beams of light through a network of "light pipes."

By the early 1960s, scientists (most working for the phone companies) were right on the doorstep of creating the first fiber optic telephone networks. Three components, in particular, were proving to be increasingly compatible:

- Small, compact Light Emitting Diodes (LEDs)
- Lasers
- Glass optical fibers

Researchers from throughout the world put those items through assorted scientific hoops day after day, year after year, until they arrived at the basis for the largest and most efficient fiber optic telephone communications in existence today.

In 1976, the Bell System installed a trial fiber optic telephone system, and one year later had a commercial system in operation near Chicago. The phenomenal reliability of that system was in large part responsible for the rapid acceptance of fiber optic networks today. Bell's "acceptable" percentage of "outages" or out-of-operation-due-to-failure-time for its existing wire and microwave carrier system was .02 percent. The new fiber optic set-up, even while the bugs were still being removed, had a downtime average of .0001 percent. Small wonder that engineers and financiers alike started thinking: "Fiber optics...hmmm.....sound good....sound very good."

## Optical Fiber: The Workhorse Today

Optic fibers are usually made of plastic or glass. Plastic fibers cost less than glass but they lose light more readily. Both consist of two essential layers of transparent optical materials, core and cladding.

Viewed from one end, as in **Figure 3**, the fiber materials appear in cross section as concentric circles, with a common center, or axis, thus the term coaxial. The outer layer is called cladding; the inner layer, which carries the light, is called the core. What makes this little combination workable is the concept we discussed earlier, called the refractive index. The

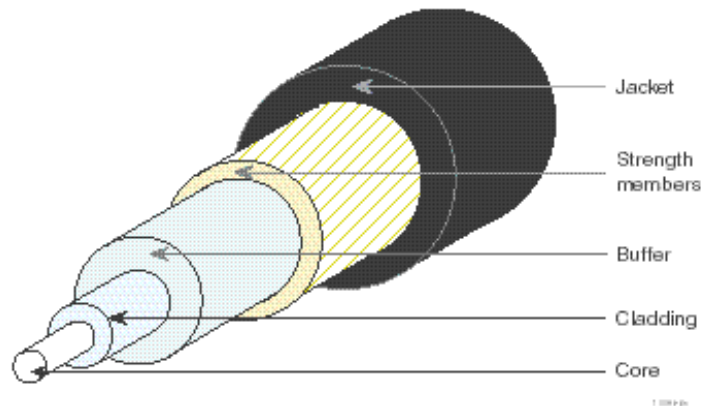

**Figure 3. Cross-section of a typical optical cable.**

cladding of an optical fiber has a lower refractive index than that of the core, and that simple difference helps trap light rays within the core, rather than allowing them to wander off into space.

When light enters an optical fiber, it travels in a straight line until it strikes the boundary between core and cladding. At that point, light is deflected back into the core and proceeds once again in a straight line until it strikes the core/cladding boundary again. The process repeats itself time and again, and it permits light to negotiate curves in the fiber by sort of ricocheting its way around the turns.

Whether we're talking glass or plastic, however, one principle works the same for both, and that's a little jewel known as **Snell's Law** – the thing that explains the ricochet-around-the-turns process we described above.

The amount that light bends depends partly on two materials having different refractive indices (as in optical fiber) but it also depends on the **angle** at which the light ray strikes the boundary between the two materials. That "incoming" light ray is known as the **incident** ray, and the "outgoing" light ray which bounces off the surface is known as the **reflected** ray.

Mr. Snell (his full name was Willebrod Snell van Royen), a Dutch mathematician, birth date unknown, explained in 1621 how light is bent, by explaining the relationship between angles of incidence and angles of transmission. **Figure 4** depicts these two angles. Note that both angles are measured from a line drawn perpendicular to the surface, at the point where the incident ray strikes.

Here's the equation:

$$\eta_1 \cdot \sin \theta_1 = \eta_2 \cdot \sin \theta_2$$

The  $\eta_1$  and  $\eta_2$  are the respective refractive indices of the two materials involved (in an optical fiber these would be the refractive indices of the core and cladding).  $\theta_1$  is the angle of incidence;  $\theta_2$  is the angle of transmission.

Snell's Law isn't limited to the bending of light, though. It also helps explain how light can be reflected from a

surface. That's handy for us, because if light couldn't be reflected, our optical fiber would be just so much excess hose, rather than the communications wonder it is.

When an incident light ray strikes the boundary surface between our two materials at a 90-degree angle, most of that light is going to penetrate the materials and keep on going. The same will be true if the incident angle is very small — say on the order of a few degrees away from the perpendicular.

However, as Snell's law tells us, there is a point — otherwise known as the **critical angle** (when the incident light ray is leaning well away from the perpendicular) — when the incoming

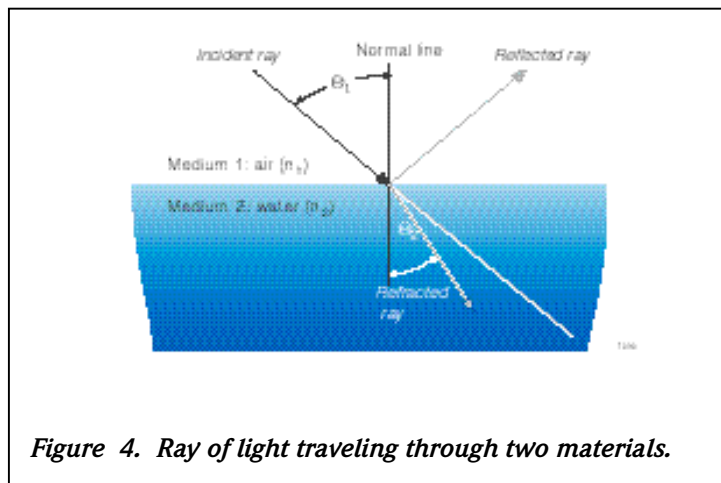

**Figure 4. Ray of light traveling through two materials.**

light will be totally reflected off the boundary between the two materials, as in our optical fiber. Stated another way: If light traveling through one material encounters another material having a lower index of refraction, and if that light strikes the boundary between the materials at a low-enough, or "glancing" angle, it cannot escape from the first material. This is where we get the term **total internal reflection**, which explains how light is guided in an optical fiber.

## There is Always a New Frontier

We've come quite a distance in time and technology since the days when Galileo grappled with the awesome speed of luminous energy. Today, *knowing* the speed of light isn't so important to us as our ability to *control* the way in which light travels. Through the marvels of fiber optics, we have achieved partial control, but we are only on the threshold of new discovery. Just as people in John Tyndall's day wanted to throw a few curves into the flight path of light, you can bet that people today (perhaps even you!) are thinking of ways to disprove old beliefs, to overcome the challenges of the unknown, and to master the mysteries of science with innovation and determination.

# ACTIVITY

---

Using the **Speed of Light Apparatus** and a dual-channel oscilloscope you will be able to measure the speed of light in a transparent medium.\* In this case, the medium is plastic optical fiber.

The transmitter portion of the apparatus generates more than 500,000 light pulses per second, which appear as a cone of red light leaving the red LED. When one end of the fiber is connected to an LED and the other end to a detector or receiver, our red light will make a circular trip through the fiber. The time required for these red pulses to travel through a 20-meter-long fiber is about 100 billionths of a second, or 100 nanoseconds.

A bit on the quick side? Rather. However, with the aid of an oscilloscope, this becomes a straightforward, practical, and visually rewarding demonstration of how an elusive natural phenomenon such as light can be captured (briefly) and measured by people who put their minds to work.

## Materials Required for the Project:

### *Speed of Light Module, which includes:*

- Speed of Light Apparatus \*
- 110 VAC-to-DC power adapter - use only the one provided
- 15 centimeters of plastic fiber<sup>†</sup>
- 20 meters of plastic fiber<sup>†</sup>

### *Required but not included:*

- Dual-channel oscilloscope, 20-MHz bandwidth or greater  
(time-base measurement capability of 0.1 micro-seconds or less)
- 2 oscilloscope probes

\* If you purchased your Speed of Light Apparatus as a kit, you must first assemble it, following the instructions in the Assembly portion of this manual. If the kit was assembled at the factory, you may proceed with **Equipment Setup** following.

† Check the ends of the fiber to see if they are polished and flat. If not, go to the Fiber Preparation section and polish the ends of the fiber cable before going further.

## Equipment Setup

1. Turn on the oscilloscope.
2. On the oscilloscope make the following settings:
  - Set the Horizontal Mode Switch on A
  - Set the Triggering Mode on Auto
  - Set the Trigger Source Switch on Channel 1
  - Set Triggering on Positive Slope
  - Set the voltage control of input Channel 1 on 1-volt per division
  - Set the voltage control of input Channel 2 on 0.5-volt per division
  - Set the input coupling of both channels on AC
  - Set the Timebase on 50 nanoseconds per division
  - Set Vertical Mode to ALT.
3. Connect the probe of Channel 1 to the (blue) test point marked "**Reference**" on the Speed of Light Apparatus.
4. Connect the Ground lead of Channel 1's probe to the ground test point just below the **Reference** test point. (It is not essential to use probes with ground leads, but the waveforms on the oscilloscope screen will have better shapes from which measurements can be made.) If your probes do not have ground leads, use the ground on the oscilloscope.
5. Connect the probe of Channel 2 to the "**Delay**" (blue) test point on the apparatus.
6. Connect the ground lead from Channel 2's probe to the ground test point just below the "**Delay**" (white) test point.
7. Move Channel 2's input selector to the "ground" position.
8. Plug the connector of the 110 VAC-to-DC power adapter into the receptacle on the left side of the apparatus. Plug the AC adapter into a 110 VAC 60 Hz receptacle.
9. As soon as the AC adapter supplies power to the apparatus, the yellow LED should light up. **D3**, the fiber optic LED, should also be visible if you lean down to look sideways into the front of the blue fiber optic housing.
10. Turn the "**Calibration Delay**" knob on the apparatus to the 12 o'clock position.
11. Loosen the fiber optic cinch nuts on the fiber optic LED **D3** and detector **D8**.
12. Select the 15-cm length of plastic fiber and insert one end of it into LED **D3** until it is seated, then *lightly* tighten the fiber optic cinch nut.
13. Insert the other end of the optical fiber into detector **D8** until seated, then tighten its fiber optic locking nut.

## Calibration

It is important to calibrate this apparatus to ensure accurate results for the remainder of the activity. The calibration will be done with 15 cm of optical fiber installed to simulate a distance of zero. Admittedly, 15 cm is not zero range, but the time delay in 15 cm of fiber is less than one nanosecond — not enough to affect the accuracy of this apparatus and test equipment. If at any time your results differ from those we describe, you should go back and double-check your measurements.

1. A pulse should now be observed as Channel 1 on the oscilloscope CRT screen. It should be approximately 3.5 volts in amplitude and 35 nanoseconds in pulse width. The pulse width is measured at 50% amplitude of the pulse. See **Figure 5**. This is the calibration pulse which will serve as a reference pulse for subsequent measurements.
2. Turn the input selector of Channel 2 from ground to AC coupling.
3. A second pulse from 1 to 1.5 volts in amplitude and 75 nanoseconds wide should also now be visible. This is the pulse received through the 15 cm fiber optic cable.
4. Using the vertical positioning knobs, align the bases of Channel 1 and Channel 2 traces with the second grid line above the bottom of the CRT screen.
5. Using the horizontal positioning knob, align Channel 1 with the second grid line from the left of the CRT screen.
6. Rotate the **Calibration Delay** knob on the apparatus until the peak of the received pulse coincides with the peak of the reference pulse as shown in **Figure 6**.
7. Readjust the oscilloscope's sweeptime/timebase scale to 20 nanoseconds per division. (This scale may be available only by using the 10X magnification knob on the oscilloscope. Consult the oscilloscope operator's manual if you are uncertain about how to locate the proper scale.)
8. Fine-tune the Calibration Delay Adjustment knob on the apparatus to achieve best overlap/coincidence of the reference and received pulses.

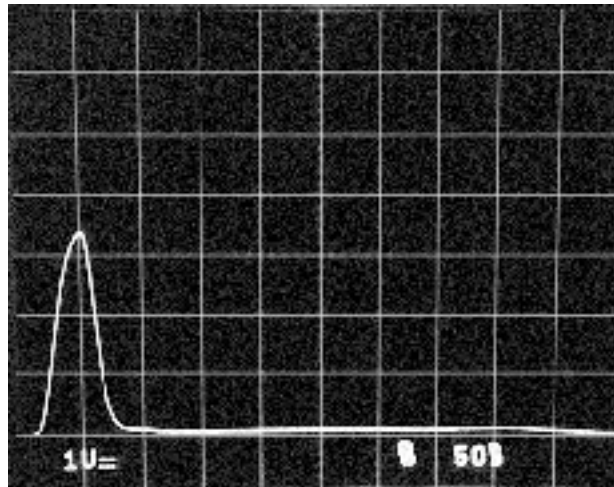

*Figure 5. Photograph of the oscilloscope screen with the "Reference" pulse displayed as Channel 1.*

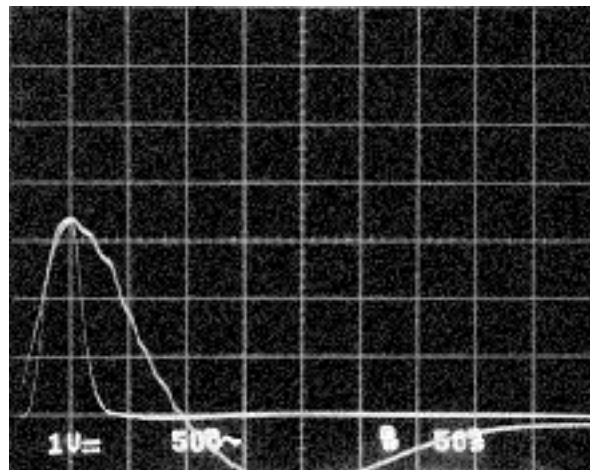

*Figure 6. Correct alignment of Channel 1 and 2 oscilloscope traces for proper Speed of Light Apparatus calibration.*

- Carefully loosen the fiber cinch nuts on LED **D3** and Detector **D8** and remove the 15 cm length of fiber.

## Measurement

Finally . . . we are going to make our speed of light measurement! Using the oscilloscope we will measure the time required for the red LED light pulses to travel through 20 meters of plastic fiber.

- Insert one end of the 20-meter plastic fiber gently but firmly, into LED **D3** until the fiber is seated. Lightly finger-tighten the fiber optic cinch nut on the LED.
- Insert the other end of the fiber into Detector **D8** and lightly tighten the fiber optic cinch nut.
- Observe the display on the CRT screen of the oscilloscope. The received pulse should now have moved to the right of the reference pulse, with a reduced amplitude of approximately 50%. See **Figure 7**.
- Very carefully measure the time difference between the reference pulse and the delay pulse, in nanoseconds. Make the measurement from the second vertical graticule used in your initial calibration to the peak of the relocated received pulse (that is, the received pulse generated when using the 20-meter optical fiber).
- Write down the result of your measurements from Step 4. (It should be between 90 and 110 nanoseconds.)

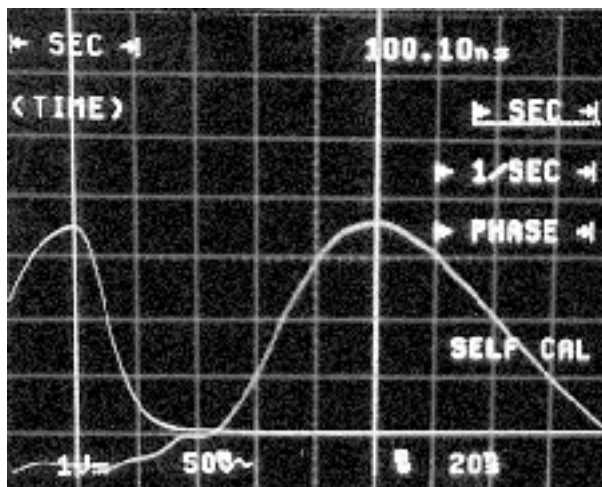

*Figure 7. Oscilloscope display showing approximate positions of the reference pulse and the received pulse delayed through 20 meters of fiber.*

## Speed of Light Calculation

We now have just about all the information we need to calculate the speed of light. Because the light in our demonstration is traveling through a plastic fiber, which is not a vacuum, we need to know the index of refraction of the plastic fiber to compensate for the slower light speed.

As you will recall (or at least, we hope you recall, heh, heh) from the preceding **Background Information** sections here, the index of refraction of a particular medium equals the speed of light in a vacuum divided by the speed of light in the medium. ( $n = c/v$ ).

"Ahhh," you're probably saying to yourself, "It's all coming back to me now." Sure.

Today we won't attempt to measure the index of refraction of the plastic fiber. That's a project for another day. For now, we'll rely on the manufacturer's specifications, which say our fiber's refractive index is 1.5.

Use the familiar equation:

$$c = \frac{n \cdot l}{t}$$

where

$c$  = the speed of light in a vacuum

$n$  = the index of refraction of the plastic fiber

$l$  = the length of the plastic fiber, in meters

$t$  = the travel time of light through the 20 - meter fiber, in nanoseconds

Now take the measurement number you wrote down and substitute it for 't' in the equation. If the results of your measurement resembled 100 nanoseconds, your numbers should look something like this:

$$\begin{aligned} c &= \frac{1.5 \cdot 20 \text{ m}}{100 \times 10^{-9} \text{ seconds}} \\ &= 3 \times 10^{-8} \text{ meters / second} \end{aligned}$$

In other words — the speed of light.

Just to make sure you understand why you feel proud about yourself (rightfully so) for having arrived at the right numbers, run back through the preceding **Background Information** sections.

If you begin with people's initial curiosity about the speed of light, more than 500 years ago, you probably can appreciate how far that curiosity — and determination, and scientific dedication, and sudden inspiration — have changed our world. The demonstration you completed so simply with your *Speed of Light Apparatus* was founded upon the endless questions and, eventually, scientific explorations, of thousands of adventurous people who dared to ask: "Why?"

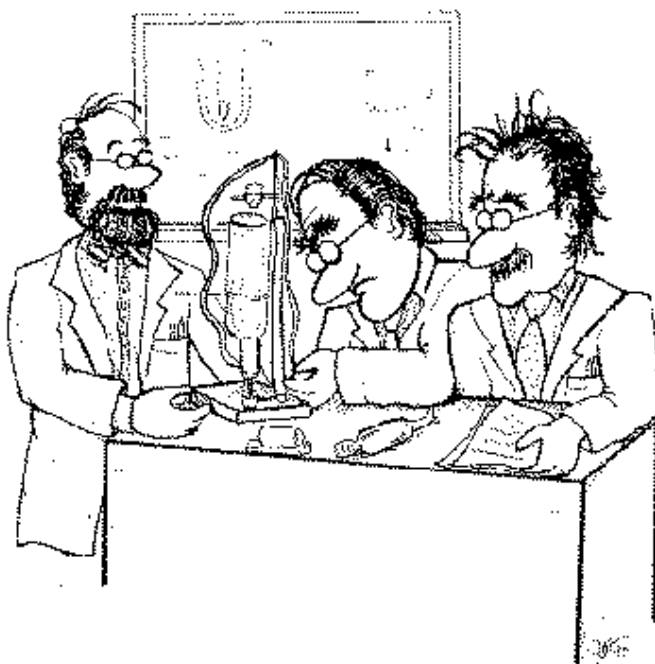



# KIT ASSEMBLY

---

If you obtained your *Industrial Fiber Optics* Speed of Light Apparatus in kit form, rather than already assembled at the factory, these instructions will explain how to get everything together and ready for operation.

## Tools and equipment required for assembly

- 25-watt soldering iron
- Needle-nose pliers
- Single-edge razor blade or sharp knife
- Small standard blade screwdriver
- Small Phillips screwdriver
- Small adjustable wrench
- Solder\*
- Water, glycerin or light oil
- Wire cutters

\* Solid-core solder is recommended for assembly. If rosin-core solder is used you may wish to purchase flux remover to make cleaning the board easier after you have finished soldering.

## Parts Identification

All the components required for this apparatus are listed in **Table 1**. Compare the contents of the kit to the list in the table before you start assembly, to ensure all components are present.

1. Identify all the resistors, using the color codes in Table 1.
2. This kit contains six axial leaded ceramic capacitors. The values of these capacitors may be denoted by a three digit code, or by color bands similar to those on the resistors.
3. Two of the capacitors have values of .047  $\mu\text{F}$ . They are identified by the code 473, or color bands of yellow, violet, orange, white.
4. The other four capacitors have values of 150 pF. They are identified by the code 151, or color bands of brown, green, brown, silver.
5. Identify all the resistors, using the color codes in **Table 1**.
6. Locate diodes **D2, D4, D5, D6** and **D7**. They are the red glass components (with a black cathode marking on one end) and wire leads protruding from both ends.
7. Identify the remaining components shown in **Table 1**.

**Table 1. Speed of Light Apparatus Parts List.**

P/N	Value	Description	Color Code
Q1	2N2369	NPN switching transistor	
Q2	2N5179	NPN wide bandwidth transistor	
Q3	2N5179	NPN wide bandwidth transistor	
Q4	2N5179	NPN wide bandwidth transistor	
D1		Yellow LED	
D2	1N914/1N4148	Switching diode	Blue housing, pink dot
D3	IF-E96	Fiber optic red LED	
D4	1N914/1N4148	Switching diode	
D5	1N914/1N4148	Switching diode	
D6	1N914/1N4148	Switching diode	
D7	1N914/1N4148	Switching diode	Black housing, orange dot
D8	IF-D91	Fiber optic photo diode	
C1	1 $\mu$ f 50 V	Electrolytic capacitor	Brown green brown silver or 151 Brown green brown silver or 151 Yellow violet orange silver 473 Brown green brown silver 151 Brown green brown silver 151 Yellow violet orange white 473
C2	10 $\mu$ f 16 V	Electrolytic capacitor	
C3	150 pf	Axial ceramic capacitor	
C4	150 pf	Axial ceramic capacitor	
C5	.047 $\mu$ f	Axial ceramic capacitor	
C6	150 pf	Axial ceramic capacitor	
C7	150 pf	Axial ceramic capacitor	
C8	.047 $\mu$ f	Axial ceramic capacitor	
R1	1 k	1/4 watt carbon film resistor	Brown black red
R2	2.2 k	1/4 watt carbon film resistor	Red red red
R3	270 ohms	1/4 watt carbon film resistor	Red violet brown
R4	2.2 k	1/4 watt carbon film resistor	Red red red
R5	47 ohms	1/4 watt carbon film resistor	Yellow violet black
R6	2.2 k	1/4 watt carbon film resistor	Red red red
R7	2.2 k	1/4 watt carbon film resistor	Red red red
R8	10 k	Linear potentiometer	Not applicable
R9	47 ohms	1/4 watt carbon film resistor	Yellow violet black
R10	220 ohms	1/4 watt carbon film resistor	Red red brown
R11	10 k	1/4 watt carbon film resistor	Brown black orange
R12	22 ohms	1/4 watt carbon film resistor	Red red black
R13	1 k	1/4 watt carbon film resistor	Brown black red
R14	4.7 k	1/4 watt carbon film resistor	Yellow violet red
R15	2.2 k	1/4 watt carbon film resistor	Red red red
R16	10 k	1/4 watt carbon film resistor	Brown black orange
U1	7805	Linear voltage regulator	
U2	TLC555CP	CMOS timer	
U3	74LS221	TTL dual monostable	
U4	DB101	Bridge rectifier	
H1		2.1 mm power jack	
H2		Test point, white (2)	
H3		Test point, blue (2)	
H4		Printed wiring board	
H5		Six inches 24 gauge wire	
H6		Chassis	
H7		110 VAC-to-DC power adapter	
H8		Knob	
H9		2-56 machine screw with nut (2)	
H10		4-40 machine screw with nut	
H11		#4 3/8" sheet metal screws (6)	
H12		Rubber feet (4)	
H13		Polishing paper	
F1		20-meter fiber	
F2		15-centimeter fiber	

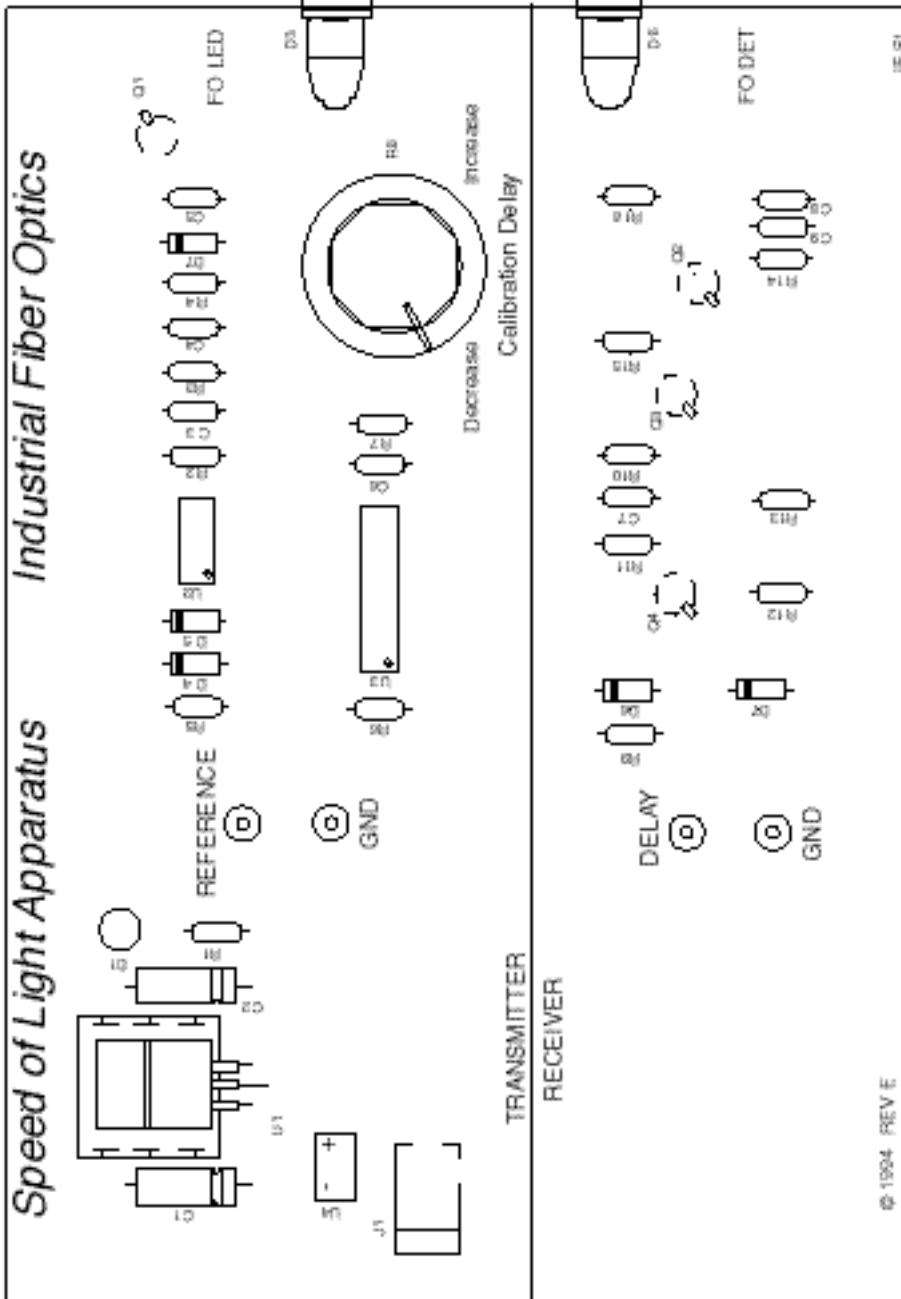

DWG SHELL	INDUSTRIAL FIBEROPTICS
CHK	TEMPR, AZ
DRN	DMHL
DWT	000204
REV	REV
REV	E
DWG NUMBER	IF-SL

SILK SCREEN - COMP SIDE

Figure 8. Printed wiring board legend showing the correct parts placement for assembly of the Speed of Light Apparatus.



## Assembly Procedure

All components are to be mounted on the side of the blue printed wiring board with the white printing except for **R8**. All soldering is to be completed on the opposite side. Avoid applying prolonged heat to any part of the board or component to prevent damage. After soldering each component, trim its lead length flush with the solder.

A copy of the printed wiring board's legend is shown in *Figure 8*. Use it to properly place the components on the board. A copy of the circuit schematic is also included as *Figure 9*.

1. Identify pin 1 of **U2** and **U3** (the lower left pin of the integrated circuit [IC], when viewed from above). Insert the ICs into designated spots marked on the printed circuit board, with pin 1 to your lower left. The lettering on the ICs will face the same direction as the markings on the board. Solder in place.
2. Identify the plus and minus signs on **U4** and match them to the same signs on the printed circuit board.
3. Insert resistors **R1** through **R7**, and **R9** through **R16**, one at a time into the printed wiring board and solder. Do not install the potentiometer **R8** yet.
4. Orientation of diodes **D2**, and **D4** through **D7** is critical. Line up the "bar" markings on the diode with the bar on the printed circuit board diode positional indicators. Insert and solder.
5. **C1** and **C2** are capacitors which are sensitive to the direction in which they are installed. Identify the wire lead marked with minuses (- - -), then the round pad on the printed wiring board corresponding to that capacitor. Match up the two, insert the leads properly into the board, and solder each capacitor into place.
6. There is no positive/negative orientation of capacitors **C3** through **C8**. Identify each, insert leads through the board and solder in place.
7. **Q1** is the only 3-lead metal "can" transistor in your kit. Align the metal tab protruding from the can with the white ink tab on the printed wiring board and solder.
8. **Q2**, **Q3**, and **Q4** are 4-lead metal can transistors. Align the metal tab protruding from the can with the white ink tab on the printed wiring board, then solder all leads into place.
9. Locate the square pad within the area on the wiring board designated for placement of **D1** (the yellow LED). Insert the shortest leg of **D1** (the cathode) into the square pad on the printed wiring board, and solder into place.
10. **U1** will be installed with the flat metal tab contacting the board. Use needle-nose pliers to grip the three leads approximately 0.3 inch (7.5 mm) out from the square black base and bend them downward at a 90° angle to penetrate the board. Insert the 4-40 screw through the metal tab and the wiring board, and fasten it in place using the nut provided. Solder the three leads onto the board.
11. Install the two white test points **H2** at the locations on the wiring board marked as "GND" connections, then solder.

12. Install the two blue test points that are marked as "**Reference**" and "**Delay**" and solder to the wiring board.
13. Clean the printed circuit board with soap and warm water to remove solder residue. Soapy water will not harm the components as long as electrical power is not being applied — in which case you don't want to get anywhere near water anyway, for safety's sake. If you used a rosin core solder, clean the board with flux remover before washing in soap and water. Rinse thoroughly. Shake the board to remove water from under the ICs. Wipe everything dry with paper towels and let it air-dry for 30 minutes.
14. Insert **D3** and **D8** in designated areas on the printed circuit board and secure in place with the 2-56 screws and nuts provided. Solder each lead.
15. Remove the nut and washer from the potentiometer **R8**. Insert the shaft of the potentiometer through the bottom of the board, aligning the tab on the pot with the hole on the board. Use the washer and nut to tighten **R8** securely to the board.
16. Turn the board over to expose its bottom, with the fiber optic emitter **D3** and detector **D8** pointing away from you. Solder a 5-cm (1.5") 24-gauge jumper wire from the left pin of the pot to the solder pad just underneath it. Solder another jumper of the same length between the pot's middle and right pins, then to the open solder pad that is connected to **R7**.
17. Place the power supply jack onto the printed wiring board and solder all three of its leads into place. Apply heat and solder sparingly to prevent the solder from flowing down into the jack.
18. The printed wiring board is now assembled and ready for installation in the chassis provided. Using the six #4 sheet metal screws provided, fasten the printed circuit board onto the raised supports of the chassis. Do not overtighten the screws or you could crack the chassis.
19. Remove the adhesive backing from the four rubber feet provided, and attach one to each corner of the chassis base.

Proceed to the **Fiber Preparation** section to finish the ends of the fiber cable.

# FIBER PREPARATION

Cutting and polishing the ends of plastic fiber cable is easy. In addition to the items contained in your kit, you need only a polishing liquid (water, glycerin, or light oil), a sharp knife or single-edge razor blade, and a wire stripper. The 600-grit paper included in the kit for polishing fiber can be reused by rinsing it under tap water to remove any polishing residue. To polish the two fiber optic cables, complete Steps **1** and **2** below, for both ends of each fiber.

1. Cut 1 to 2 mm off the end of the fiber cable with the razor blade or sharp knife, trying to get as square a cut as possible.
2. Wet the 600-grit polishing paper with water or light oil and place the paper, abrasive side facing up, on any hard flat surface. Polish the end of the fiber by moving it in a "Figure 8" pattern against the paper, while holding the fiber perpendicular to the polishing surface. Supporting the fiber against a flat perpendicular object during polishing will help support the flexible fiber and result in a better/flatter termination. After 20 Figure 8s, examine the end of the fiber. (A microscope or magnifying glass is helpful, but not required.) If the end is cloudy, not flat, or has scratches, repeat **Step 2**.

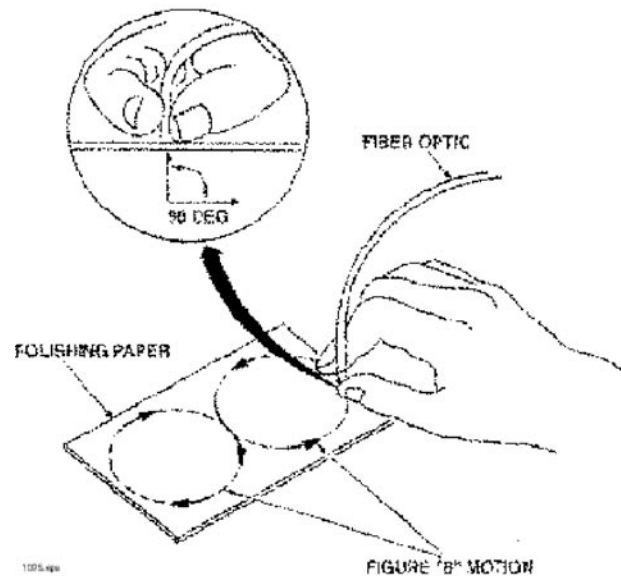

*Figure 10. Figure-9 pattern used for polishing the fiber ends..5*

Your **Speed of Light Apparatus** is now ready for operation. Turn to the **ACTIVITY** section of this manual for step-by-step instructions on how to operate the apparatus.

# REFERENCES

---

Following is a list of books, magazines, and other publications which may be useful in the study of fiber optics. If the title does not mention fiber optics, please still consider it a worthwhile source of information, since fiber optic systems span multiple technologies.

## BOOKS

---

### INTRODUCTORY

*Fiber Optics: A Bright New Way to Communicate*, Billings, Dodd, Mead & Company, New York, NY 1986

*The Rewiring of America: The Fiber Revolution*, David Chaffee, Academic Press, Inc., Orlando, FL 32887 1988

*Understanding Fiber Optics*, Second Edition, Hecht, Howard W. Sams, 201 West 103rd Street, Indianapolis, IN 46290 1989

*Fiber Optics Communications, Experiments & Projects*, Boyd, Howard W. Sams, 4300 West 62nd Street, Indianapolis, IN 1982

*Technician's Guide to Fiber Optics*, Sterling, AMP Incorporated, Harrisburg, PA 17105, 1987 (Paperback), Delmar Publishers, 2 Computer Drive West, Box 15-015, Albany, New York 12212-9985 (Hardbound version)

*Fiber Optics Handbook*, Second Edition, Hentschel, Hewlett Packard, 1988

### ADVANCED

*Fiber Optic Communications*, Fourth Edition, Palais, Prentice-Hall Publishing, 1998

*Optical Fiber Transmission*, Basch, Howard W. Sams, 4300 West 62nd Street, Indianapolis, IN 1986

### COLLEGE LEVEL

*An Introduction to Optical Fibers*, Cherin, McGraw-Hill Book Company, 1983

*Fiber Optic Handbook for Engineers and Scientists*, Allard, McGraw-Hill Publishing, New York, NY 1990

*Fiber Optics*, James C. Daly, CRC Press, Inc., 2000 Corporate Blvd, N.W., Boca Raton, FL 1986

*Fiber Optics in Communication Systems*, Elion and Elion, Marcel Dekker, Inc. 1978

*Pulse Code Formats for Fiber Optic Communications*, Morris, Marcel Dekker, Inc. 1983

*Optical Fibre Sensing and Signal Processing*, Culshaw, Peter Peregrinus LTD., 1984

*Principles of Optical Fiber Measurements*, Marcuse, Academic Press, 1974

*Semiconductor Devices for Optical Communications*, Kressel, Springer-Verlag, Inc., 1980



## **SAFETY**

*Safety with Lasers and Other Optical Sources*, Stiney and Wolbarsht, Plenum Press, 1980

*Safe Use of Lasers*, ANSI Standard Z136.1, LIA, 12424 Research Parkway, Suite 130, Orlando, FL 32826

*Safe Use of Optical Fiber Communications Systems Utilizing Laser Diodes & LED Sources*, ANSI Standard Z136.2, LIA, 12424 Research Parkway, Suite 130, Orlando, FL 32826

*A User's Manual for Optical Waveguide Communications*, Gallawa, U.S. Department of Commerce

## **Monthly publications**

The first two items are journals which are available to members of the respective professional societies. The last four are trade magazines available free of charge to qualified readers.

*Applied Optics*, Optical Society of America, 1816 Jefferson Place, NW, Washington, DC 20036

*Optical Engineering*, SPIE, P. O. Box 10, Bellingham, WA 98227

*Fiberoptic Product News*, Gordon Publications, Inc., Box 1952, Dover, NJ 07801

*Laser Focus World*, PenWell Publishing Co., 1421 S. Sheridan, Tulsa, OK 74112

*Lightwave Magazine*, PenWell Publishing Co., 1421 S. Sheridan, Tulsa, OK 74112

*Photonics Spectra*, The Optical Publishing Co., Berkshire Common, Pittsfield, MA 01202-4949

## **Fiber Optic Buyer's Guides**

*Fiberoptic Product News Buying Guide*, Gordon Publications, Inc., Box 1952, Dover, NJ 07801

*Lightwave Buyer's Guide*, PenWell Publishing Co., 1421 S. Sheridan, Tulsa, OK 74112

## **Organizations**

Optical Society of America, 1816 Jefferson Place, NW., Washington, DC 20036

Society of Photo-Optical Instrumentation Engineers (SPIE), P. O. Box 10, Bellingham, WA 98227

Laser Institute of America, 12424 Research Parkway, Suite 130, Orlando, FL 32826

# GLOSSARY

---

**Absorption.** In an optical fiber, the loss of optical power resulting from conversion of that power into heat. See also: **Scattering**.

**Acceptance Angle.** The angle within which an optical fiber will accept light for transmission along its core. This angle is measured from the centerline of the core.

**Angle of Incidence.** The angle formed between a ray of light striking a surface and a line drawn perpendicular to that surface at the point of incidence (the point at which the light ray strikes the surface).

**Angstrom.** ( Å ) A unit of length often used to characterize light. An Angstrom is equal to 0.1 nm or  $10^{-10}$  meters. The word is often spelled out as Angstrom(s) because the special symbol is not available on typewriters and older printers.

**Attenuation.** Reduction of signal magnitude, or loss, normally measured in decibels. Fiber attenuation normally is measured per unit length in decibels per kilometer.

**Cable.** A single fiber or a bundle, sometimes including strengthening strands of opaque material covered by a protective jacket.

**Cladding.** The layer of glass or other transparent material surrounding the light-carrying core of an optical fiber. It has a lower refractive index than the core. Coatings may be applied over the cladding.

**Connector.** A device mounted at the end of a fiber optic cable, light source, receiver or housing that mates to a similar device to couple light optically into and out of optical fibers. A connector joins two fiber ends or one fiber end and a light source or detector.

**Core.** The central part of an optical fiber that carries the light.

**Coupler.** A device which connects three or more fiber ends, dividing one input between two or more outputs or combining two or more inputs into one output.

**Critical Angle.** The smallest angle of incidence at which light will undergo total internal reflection.

**Detector.** A device that generates an electrical signal when illuminated by light or infrared radiation. The most common in fiber optics are photodiodes, photodarlingtontons and phototransistors.

**Fall time.** Typically specified as the time required for a signal to fall from 90 percent to 10 percent of its original negative or positive amplitude. See also: **Rise time**

**Fiber.** The optical wave guide, or light-carrying core or conductor. Generally refers to the combination of optical core and cladding. See also: **Core; Cladding**

**Fiber buffer.** A buffering material that is used to protect an optical fiber's core and cladding from physical damage.

**Fiber optics.** A branch of optical technology that deals with the transmission of radiant energy through optical waveguides generally made of glass or plastic.