



Chipsmall Limited consists of a professional team with an average of over 10 year of expertise in the distribution of electronic components. Based in Hongkong, we have already established firm and mutual-benefit business relationships with customers from,Europe,America and south Asia,supplying obsolete and hard-to-find components to meet their specific needs.

With the principle of “Quality Parts,Customers Priority,Honest Operation,and Considerate Service”,our business mainly focus on the distribution of electronic components. Line cards we deal with include Microchip,ALPS,ROHM,Xilinx,Pulse,ON,Everlight and Freescale. Main products comprise IC,Modules,Potentiometer,IC Socket,Relay,Connector.Our parts cover such applications as commercial,industrial, and automotives areas.

We are looking forward to setting up business relationship with you and hope to provide you with the best service and solution. Let us make a better world for our industry!



Contact us

Tel: +86-755-8981 8866 Fax: +86-755-8427 6832

Email & Skype: info@chipsmall.com Web: www.chipsmall.com

Address: A1208, Overseas Decoration Building, #122 Zhenhua RD., Futian, Shenzhen, China



General information

IPM for typical voltages up to 690 V_{RMS}
Rated output current 650 A_{RMS}

Features

- Integrated current, voltage and temperature measurement
- Tvjop max=150°C
- Real time Tvj simulation
- IGBT4 technology
- Smart protection
- TIM and pressfit technology
- Modbus interface
- 100% tested IPM
- ROHS compliant
- Integrated chip current : 2400A
- Integrated chip voltage: 1700V



Topology	half bridge
Application	Energy Storage, Smart Grid, Wind, Drives, Solar
Heatsink	air cooled
Implemented sensors	voltage, current, temperature
Driver signals IGBT	+15V
Approvals	UL61800-5-1
Sales - name	IFF2400P17AE440989

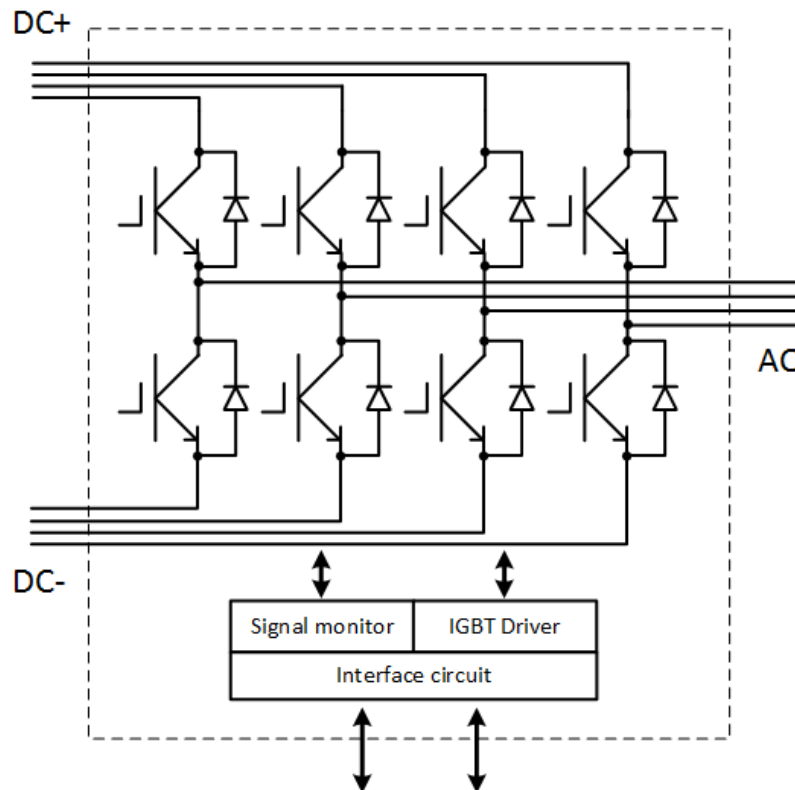

prepared by: OW	date of publication: 2018-06-22
approved by: ZF	revision: 2.3

Preliminary data

Characteristic values

IGBT characteristic value

			min.	typ.	max.	
Collector-emitter voltage	$I_C = 2400\text{ A}, T_{vj} = 25^\circ\text{C}$	$V_{ce\text{ sat}}$		1.95	2.30	V
	$I_C = 2400\text{ A}, T_{vj} = 150^\circ\text{C}$			2.45		V
Turn on energy loss	$I_C = 2400\text{ A}, V_{DC} = 900\text{ V}, L_S = 17\text{ nH}, T_{vj} = 25^\circ\text{C}$	E_{on}		730		mJ
	$I_C = 2400\text{ A}, V_{DC} = 900\text{ V}, L_S = 17\text{ nH}, T_{vj} = 150^\circ\text{C}$			1170		mJ
Turn off energy loss	$I_C = 2400\text{ A}, V_{DC} = 900\text{ V}, L_S = 17\text{ nH}, T_{vj} = 25^\circ\text{C}$	E_{off}		460		mJ
	$I_C = 2400\text{ A}, V_{DC} = 900\text{ V}, L_S = 17\text{ nH}, T_{vj} = 150^\circ\text{C}$			810		mJ
Thermal resistance junction to ambient for diode due diode housing	per IPM switch, Air flow rate= 550m ³ /h	$R_{thja\text{ IGBT-<IGBT}}$		0.0619		K/W
Thermal resistance junction to ambient for IGBT due IGBT housing	per IPM switch, Air flow rate= 550m ³ /h	$R_{thja\text{ IGBT-<diode}}$		0.0492		K/W

Notes

Tinlet = 25°C

For further details about the thermal resistance please refer to the handbook.

Diode characteristic value

			min.	typ.	max.	
Forward voltage	$I_C = 2400\text{ A}, T_{vj} = 25^\circ\text{C}$	V_F		1.80	2.20	V
	$I_C = 2400\text{ A}, T_{vj} = 150^\circ\text{C}$			1.95		V
Reverse recovery energy	$I_C = 2400\text{ A}, V_{DC} = 900\text{ V}, L_S = 17\text{ nH}, T_{vj} = 25^\circ\text{C}$	E_{rec}		250		mJ
	$I_C = 2400\text{ A}, V_{DC} = 900\text{ V}, L_S = 17\text{ nH}, T_{vj} = 150^\circ\text{C}$			530		mJ
Thermal resistance junction to ambient for diode due diode housing	per IPM switch, Air flow rate= 550m ³ /h	$R_{thja\text{ diode-<diode}}$		0.0721		K/W
Thermal resistance junction to ambient for IGBT due IGBT housing	per IPM switch, Air flow rate= 550m ³ /h	$R_{thja\text{ diode-<IGBT}}$		0.0485		K/W

Notes

Tinlet = 25°C

For further details about the thermal resistance please refer to the handbook.

Absolute maximum rated values

Collector-emitter voltage	IGBT; $T_{vj} = 25^\circ\text{C}$	V_{CES}		1700		V
Repetitive peak reverse voltage	Diode; $T_{vj} = 25^\circ\text{C}$	V_{RRM}		1700		V
DC link voltage		V_{DC}		1450		V
Peak switching current		I_{peak}		4000		A
Insulation test voltage	$f = 50\text{ Hz}, t = 60\text{ s}$	V_{ISOL}		3.4		kV _{RMS}
Junction temperature	under switching conditions	T_{vjop}		150		°C
Operational ambient temperature min.		T_{amb}		-40		°C
Switching frequency operation values		f_{sw2}		10		kHz

Notes

prepared by: OW	date of publication: 2018-06-22
approved by: ZF	revision: 2.3



Preliminary data

Operation values

			min.	typ.	max.	
Rated continuous current	$V_{DC} = 1100\text{ V}$, $V_{AC} = 690\text{ V}_{RMS}$, $\cos(\varphi) = 0.85$, $f_{AC\ sine} = 50\text{ Hz}$, $f_{sw} = 3000\text{ Hz}$, $T_{inlet} = 25^\circ\text{C}$, $T_j \leq 150^\circ\text{C}$	I_{AC}		650		A_{RMS}
Power losses	$I_{AC} = 650\text{ A}$, $V_{DC} = 1100\text{ V}$, $V_{AC} = 690\text{ V}_{RMS}$, $\cos(\varphi) = 0.85$, $f_{AC\ sine} = 50\text{ Hz}$, $f_{sw} = 3000\text{ Hz}$, $T_{inlet} = 25^\circ\text{C}$, $T_j \leq 150^\circ\text{C}$	P_{loss}		4000		W

Controller interface

			min.	typ.	max.	
Auxiliary voltage		V_{aux}	19.2	24	28.3	V
Auxiliary power requirement	$V_{aux} = 24\text{ V}$	P_{aux}			48	W
Digital input level		$V_{in\ low}$			2	V
		$V_{in\ high}$	8.5		16	V
Digital output level	max. 1 mA	$V_{out\ low}$			2	V
		$V_{out\ high}$	13.5	15	16.5	V
Interlock time	default value	$t_{interlock}$		4		μs
Propagation delay for PWM	default value	t_{prop}		4		μs
Analog output for phase current	for 650 A	$V_{Iac\ ana}$		1.54		V
Over current shut down	default value, response time 15 μs	$I_{ac\ trip}$		4200		A
Analog DC link voltage sensor output	load max 5 mA, @ 1100 V	$V_{DC\ ana}$		7.86		V
Over voltage shut down	default value, response time 500 μs	$V_{dc\ trip}$		1340		V
Chip over temperature shut down	default value, response time 1000 μs	$T_{vj\ trip}$		150		$^\circ\text{C}$
Analog output for junction temperature	for 150 $^\circ\text{C}$	$V_{Tvj\ ana}$		10		V
PCB ambient over temperature shut down	default value, response time 1 s	$T_{pcb\ err}$		85		$^\circ\text{C}$
Serial BUS	Modbus, RS485			19200		Bit/s

prepared by: OW	date of publication: 2018-06-22
approved by: ZF	revision: 2.3



Preliminary data

System data

				min.	typ.	max.	
EMC robustness	according to IEC61800 at named interfaces	power	V_{Burst}	2			kV
		control	V_{Burst}	2			kV
Storage temperature			T_{stor}	-40		85	°C
Operational ambient temperature			$T_{op\ amb}$	-40		65	°C
Stray inductance			L_s		8.5		nH
Lead resistance			$R_{CC\ EE}$		1.2		mΩ
Impuls test voltage	Power to logic side, acc .IEC 61800-5-1				12		kV
Isolation test voltage	RMS, f = 50 Hz, t = 60 s		V_{ISOL}		3.4		kV
Creepage distance	Power side to heatsink across housing				13		mm
Clearance	Power side to heatsink				8		mm
Protection degree				IP00			
Pollution degree				2			
Dimensions	width x depth x height			215	338	166	mm
Weight					11.5		kg

Notes

Partical discharge test, power side to logic side, according to IEC 61800-5-1, TE > 1920V

Housing CTI > 175

For further details about the system data please refer to the handbook.

Heatsink air cooled

				min.	typ.	max.	
Air flow	$T_{air} = 25\ ^\circ C$, $P_{air} = 5.5\ hPa$, dry and dust free, measured at the side of the heat sink		$\Delta V/\Delta t$		550		m³/h
Air inlet temperature			T_{inlet}		40		°C

prepared by: OW	date of publication: 2018-06-22
approved by: ZF	revision: 2.3

Preliminary data

output characteristic IGBT/Diode
T_{vj} = 150°C

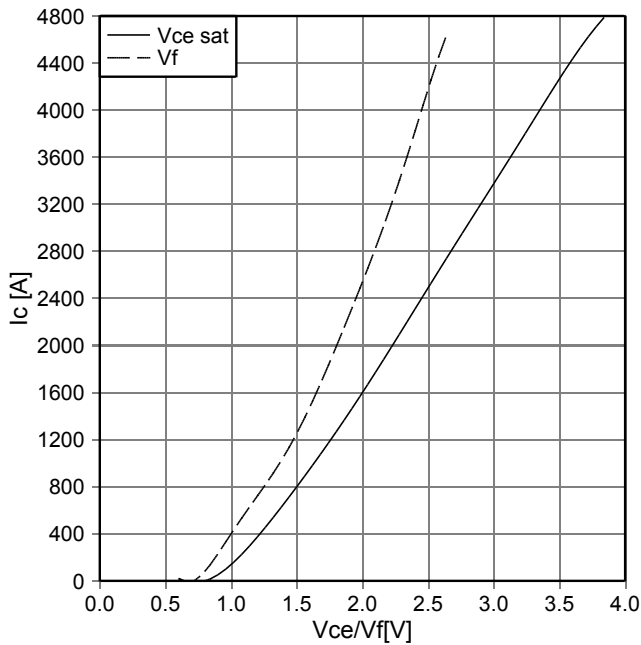

switching losses, Eon, Eoff, Erec
V_{dc} 1100V, T_{vj} = 150°C

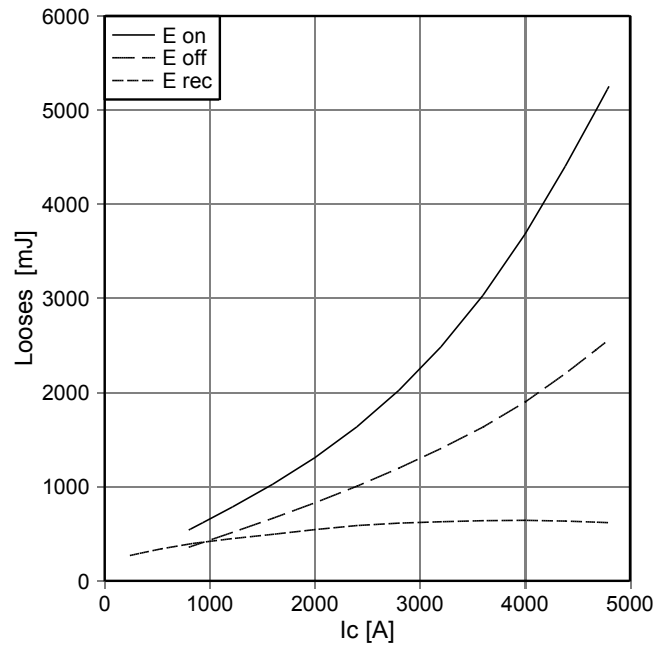

safe operating area

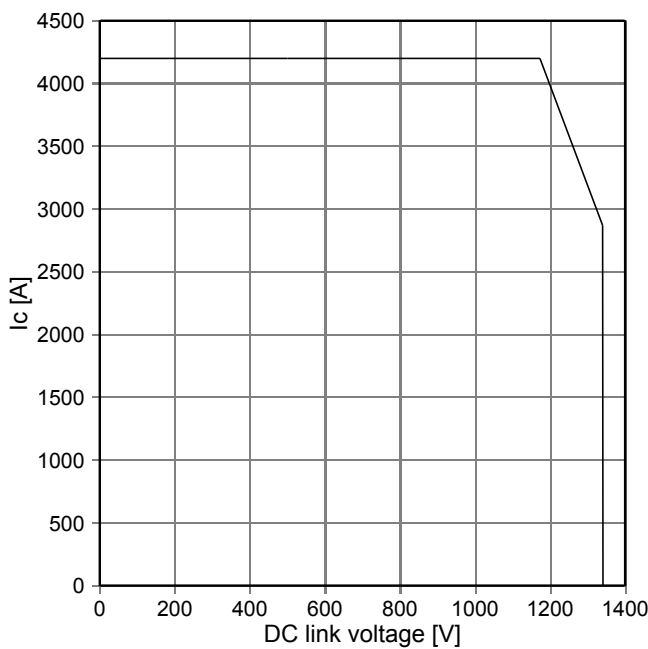

Pressure drop vs. flow rate
T_{inlet} = 25°C

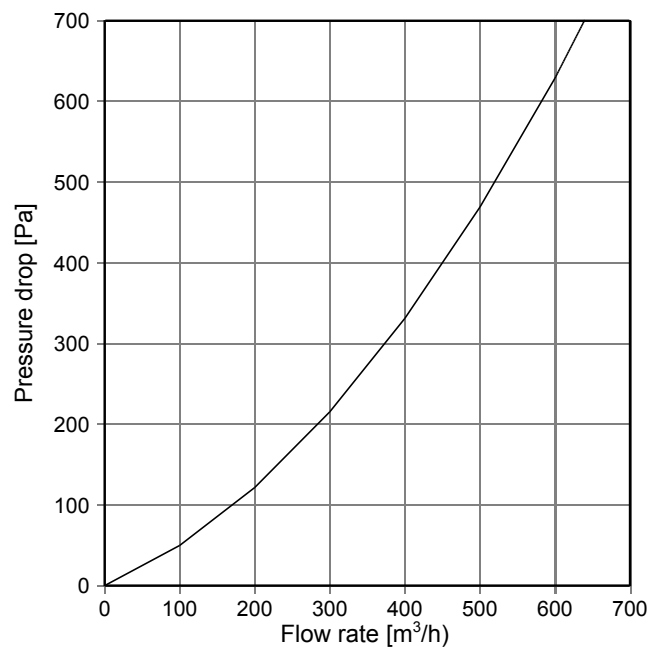

prepared by: OW	date of publication: 2018-06-22
approved by: ZF	revision: 2.3



Preliminary data

Thermal resistance vs. Flow rate
T inlet=25°C

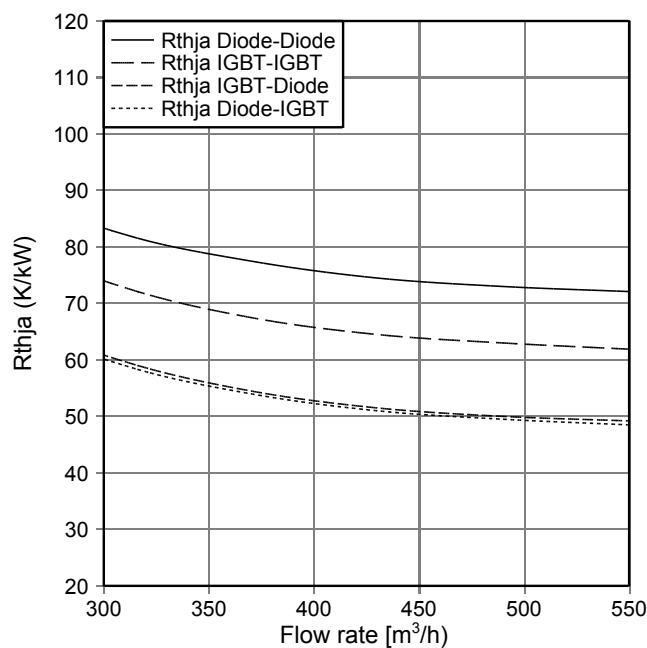

prepared by: OW	date of publication: 2018-06-22
approved by: ZF	revision: 2.3

thermal impedance
 Tinlet =25°C, Air flow rate= 550m3/h

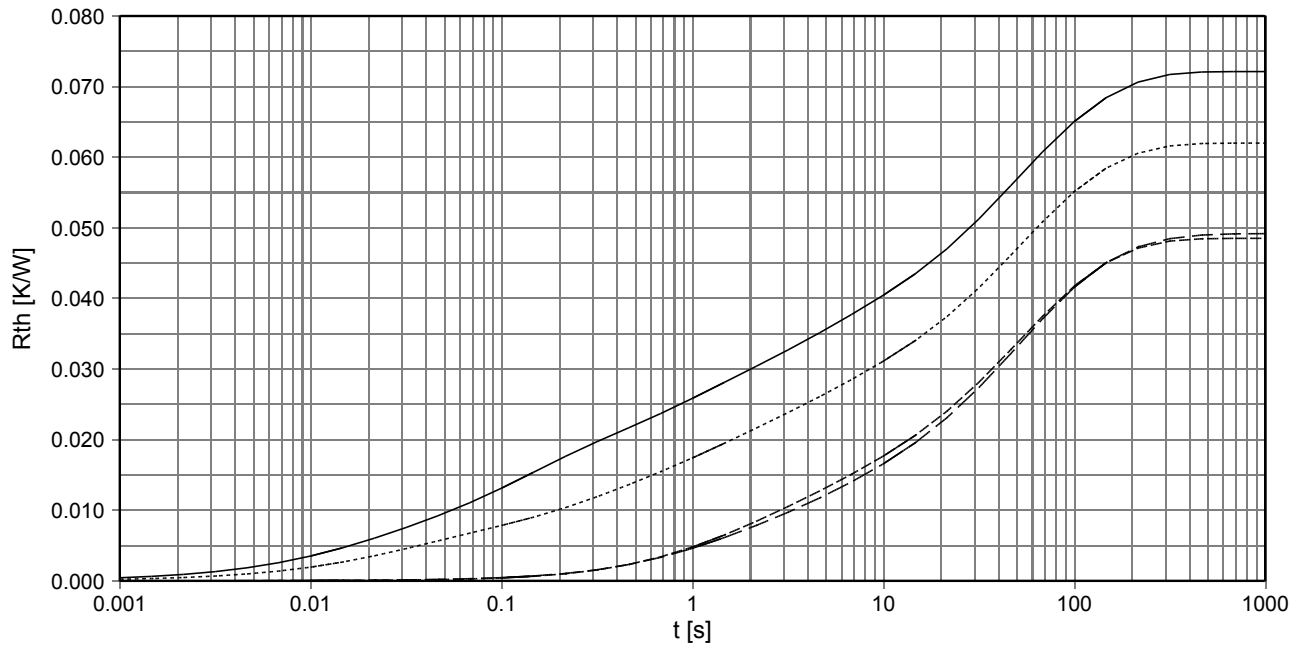

—— Rthja Diode - Diode

i:	1	2	3	4	5	6
r[K/W]:	0.0045	0.01125	0.0084	0.00975	0.01473	0.0235
τ [s]:	0.014	0.102	0.638	3.11	30.44	78

- - - Rthja IGBT - Diode

i:	1	2	3	4	5	6
r[K/W]:	-0.00052	0.00429	0.00628	0.00458	0.0263	0.00825
τ [s]:	0.172	0.942	3.525	22.34	51.9	125

- . - - Rthja Diode-IGBT

i:	1	2	3	4	5	6
r[K/W]:	-0.00059	0.00523	0.00694	0.00185	0.01666	0.01842
τ [s]:	0.164	1.165	3.71	19.85	39.7	81.6

..... Rthja IGBT-IGBT

i:	1	2	3	4	5	6
r[K/W]:	0.005	0.0047	0.0072	0.0083	0.0164	0.0204
τ [s]:	0.026	0.2	0.848	3.525	35.58	80.37

prepared by: OW	date of publication: 2018-06-22
approved by: ZF	revision: 2.3

Circuit diagram

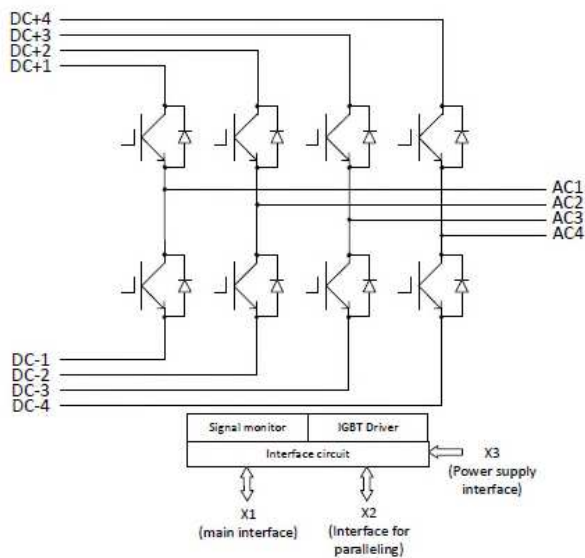

Pin configuration for X1 (main control interface)

Pin	Signal	I/O	Pin	Signal	I/O
1	24V_supply	PWR	14	GND_supply	PWR
2	24V_supply	PWR	15	GND_supply	PWR
3	+15_DC	PWR	16	GND_DC	PWR
4	Alert	OUT	17	Enable	IN
5	Fault	IN/OUT	18	Warn_OV	IN/OUT
6	ANA_Tj	ANA OUT	19	ID_det	IN/OUT
7	ANA_Vdc	ANA OUT	20	GND_ana	PWR
8	PWM_top	IN	21	PWM_bot	IN
9	Warn_OC	IN/OUT	22	GND_dig	PWR
10	ANA_lc	ANA OUT	23	Warn_OT	IN/OUT
11	TX/RX_IN+	IN/OUT	24	TX/RX_IN-	IN/OUT
12	TX/RX_Out+	IN/OUT	25	TX/RX_Out-	IN/OUT
13	Shield			Housing is shield	

Detail information for X1, X2 and X3 refer to handbook

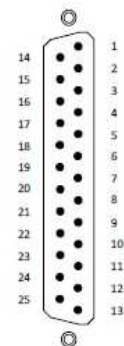

Sub-D 25, male with UNC thread

prepared by: OW	date of publication: 2018-06-22
approved by: ZF	revision: 2.3



Terms & Conditions of usage

The data contained in this product data sheet is exclusively intended for technically trained staff. You and your technical departments will have to evaluate the suitability of the product for the intended application and the completeness of the product data with respect to such application.

This product data sheet is describing the characteristics of this product for which a warranty is granted. Any such warranty is granted exclusively pursuant to the terms and conditions of the supply agreement. There will be no guarantee of any kind for the product and its characteristics.

Should you require product information in excess of the data given in this product data sheet or which concerns the specific application of our product, please contact the sales office, which is responsible for you (see www.infineon.com, sales&contact). For those that are specifically interested we may provide application notes.

Due to technical requirements our product may contain dangerous substances. For information on the types in question please contact the sales office, which is responsible for you.

Should you intend to use the Product in aviation applications, in health or live endangering or life support applications, please notify. Please note, that for any such applications we urgently recommend

- to perform joint Risk and Quality Assessments;
- the conclusion of Quality Agreements;
- to establish joint measures of an ongoing product survey, and that we may make delivery depended on the realization of any such measures.

If and to the extent necessary, please forward equivalent notices to your customers.

Changes of this product data sheet are reserved.

Safety Instructions

Prior to installation and operation, all safety notices and warnings and all warning signs attached to the equipment have to be carefully read. Make sure that all warning signs remain in a legible condition and that missing or damaged signs are replaced. To installation and operation, all safety notices and warnings and all warning signs attached to the equipment have to be carefully read. Make sure that all warning signs remain in a legible condition and that missing or damaged signs are replaced.

prepared by: OW	date of publication: 2018-06-22
approved by: ZF	revision: 2.3