



Chipsmall Limited consists of a professional team with an average of over 10 year of expertise in the distribution of electronic components. Based in Hongkong, we have already established firm and mutual-benefit business relationships with customers from,Europe,America and south Asia,supplying obsolete and hard-to-find components to meet their specific needs.

With the principle of “Quality Parts,Customers Priority,Honest Operation,and Considerate Service”,our business mainly focus on the distribution of electronic components. Line cards we deal with include Microchip,ALPS,ROHM,Xilinx,Pulse,ON,Everlight and Freescale. Main products comprise IC,Modules,Potentiometer,IC Socket,Relay,Connector.Our parts cover such applications as commercial,industrial, and automotives areas.

We are looking forward to setting up business relationship with you and hope to provide you with the best service and solution. Let us make a better world for our industry!



Contact us

Tel: +86-755-8981 8866 Fax: +86-755-8427 6832

Email & Skype: info@chipsmall.com Web: www.chipsmall.com

Address: A1208, Overseas Decoration Building, #122 Zhenhua RD., Futian, Shenzhen, China



UNCONTROLLED DOCUMENT

PART NUMBER
IFL-LX2162-16T

REV.
B

REV.	E.C.N. NUMBER AND REVISION COMMENTS	DATE
A	E.C.N. #10347.	5.20.97
B	E.C.N. #11148.	12.28.06

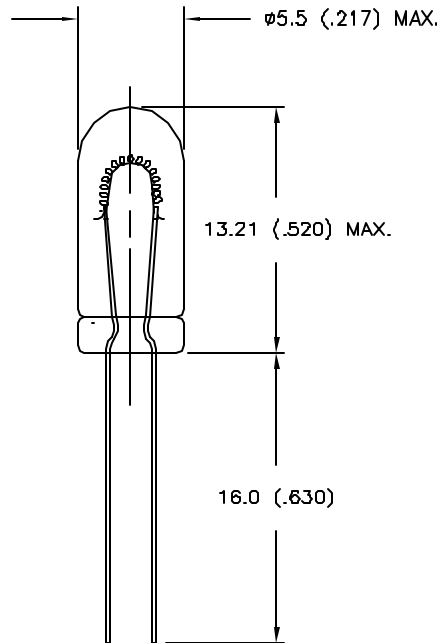

ELECTRO-OPTICAL SPECIFICATIONS

OPERATING VOLTAGE VAC OR VDC:	13-15 V
DESIGN VOLTAGE VDC OR VAC:	14
CURRENT DRAW @ DESIGN VOLTS:	100mA
M.S.C.P. @ DESIGN VOLTS:	.50 MSCP
AVERAGE LIFE @ DESIGN VOLTS:	10,000 HRS.

MECHANICAL SPECIFICATIONS

BULB SIZE AND SHAPE:	T5.8 TUBULAR
BULB GLASS TYPE:	KG12 SEMI SOFT
BASE OR LEAD FINISH:	TINNED
FILAMENT SHAPE:	C-2F
L.C.L. IF APPLICABLE:	N/A
MANUFACTURING PSS:	IFL/T 5.8 WTWL

ENVIRONMENTAL SPECIFICATIONS

VIBRATION TESTING:	MIL-E-5400N, GRAPH IV
SHOCK TEST:	MIL-STD-883 METHOD 2002 TEST CON A
OPERATING TEMPERATURE:	-50 TO +100 °C
STORAGE TEMPERATURE: <u>NOTES:</u>	-50 TO +125 °C
SOLDERABILITY OF LEADS:	MIL-STD 202F, METHOD 208D

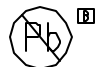

UNCONTROLLED DOCUMENT

*UNLESS OTHERWISE SPECIFIED TOLERANCES PER DECIMAL PRECISION ARE: X=±1 (±0.038), XX=±0.5 (±0.020), XXX=±0.25 (±0.010), XXXX=±0.127 (±0.005). LEAD SIZE=±0.05 (0.002), LEAD LENGTH=±0.75 (±0.030). MIN= +DECIMAL PRECISION MAX= +0.00 -DECIMAL PRECISION

REV. B	PART NUMBER IFL-LX2162-16T
T-1 3/4 WIRE TERMINAL LAMP WITH 16mm LEADS.	

CONFIDENTIAL INFORMATION
THE INFORMATION CONTAINED IN THIS DOCUMENT IS THE PROPERTY OF LUMEX INC. EXCEPT AS SPECIFICALLY AUTHORIZED IN WRITING BY LUMEX INC., THE HOLDER OF THIS DOCUMENT SHALL KEEP ALL INFORMATION CONTAINED HEREIN CONFIDENTIAL AND SHALL PROTECT SAME IN WHOLE OR IN PART FROM DISCLOSURE AND DISSEMINATION TO ALL THIRD PARTIES.

RELIABILITY NOTE
OUR MANY YEARS OF EXPERIENCE DATA ACCUMULATION INDICATE THAT SOLDER HEAT IS A MAJOR CAUSE OF EARLY AND FUTURE FAILURE. PLEASE PAY ATTENTION TO YOUR SOLDERING PROCESS.



290 E. HELEN ROAD
PALATINE, IL 60067-6976
PHONE: +1.847.359.2790
US WEB: www.lumex.com
TW WEB: www.lumex.com.tw

DRAWN BY: JC	CHECKED BY:	APPROVED BY:	DATE: 5.20.97
			PAGE: 1 OF 1
			SCALE: N/A