



Chipsmall Limited consists of a professional team with an average of over 10 year of expertise in the distribution of electronic components. Based in Hongkong, we have already established firm and mutual-benefit business relationships with customers from,Europe,America and south Asia,supplying obsolete and hard-to-find components to meet their specific needs.

With the principle of “Quality Parts,Customers Priority,Honest Operation,and Considerate Service”,our business mainly focus on the distribution of electronic components. Line cards we deal with include Microchip,ALPS,ROHM,Xilinx,Pulse,ON,Everlight and Freescale. Main products comprise IC,Modules,Potentiometer,IC Socket,Relay,Connector.Our parts cover such applications as commercial,industrial, and automotives areas.

We are looking forward to setting up business relationship with you and hope to provide you with the best service and solution. Let us make a better world for our industry!



## Contact us

Tel: +86-755-8981 8866 Fax: +86-755-8427 6832

Email & Skype: info@chipsmall.com Web: www.chipsmall.com

Address: A1208, Overseas Decoration Building, #122 Zhenhua RD., Futian, Shenzhen, China





# IFX1054G

Fault Tolerant Low Speed CAN-Transceiver

## Data Sheet

Rev. 1.0, 2009-05-12

Standard Products

## Table of Contents

<b>1</b>	<b>Overview</b> .....	<b>3</b>
<b>2</b>	<b>Block Diagram</b> .....	<b>4</b>
2.1	Circuit Description .....	5
<b>3</b>	<b>Pin Configuration</b> .....	<b>7</b>
3.1	Pin Assignment .....	7
3.2	Pin Definitions and Functions .....	7
<b>4</b>	<b>Operation Modes, Wake - Up</b> .....	<b>8</b>
4.1	Bus Failure Management .....	9
4.2	Application Hints .....	10
<b>5</b>	<b>Absolute Maximum Ratings</b> .....	<b>11</b>
5.1	Functional Range .....	11
<b>6</b>	<b>Electrical Characteristics</b> .....	<b>12</b>
<b>7</b>	<b>Application Information</b> .....	<b>17</b>
7.1	Further Application Information .....	18
<b>8</b>	<b>Package Outlines</b> .....	<b>19</b>
<b>9</b>	<b>Revision History</b> .....	<b>20</b>



## 1 Overview

### Features

- Data transmission rate up to 125 kBaud
- Low current consumption in Stand - By and Sleep operation mode, including BUS Wake - Up
- Implemented Receive - Only mode
- Optimized Electromagnetic Compatibility (EMC)
- Wake - Up input pin, dual edge sensitive
- $V_S$  Supply fail flag
- Extended bus failure management to guarantee safe operation during all bus line failure events
- Support of failure conditions
- Fully Wake - Up capability during all bus line failure conditions
- Supports one-wire transmission mode with ground offset voltages up to 1.5 V
- Prevention from bus occupation in case of CAN controller failures
- Thermal protection
- Bus line error protection
- Green Product (RoHS compliant)

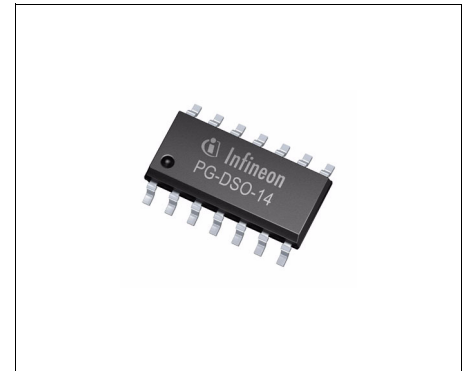

**PG-DSO-14**

### Description

The CAN-Transceiver IFX1054G works as the interface between the CAN protocol controller and the physical CAN bus - lines.

It is optimized for low-speed data transmission (up to 125 kBaud) in industrial applications. While no data is transferred, the power consumption can be minimized by multiple low power modes. In Normal operation mode a differential signal is transmitted / received. When bus wiring failures are detected the device automatically switches in a dedicated single - wire mode to maintain the CAN bus communication.

Type	Package	Marking
IFX1054G	PG-DSO-14	IFX1054G

## 2 Block Diagram

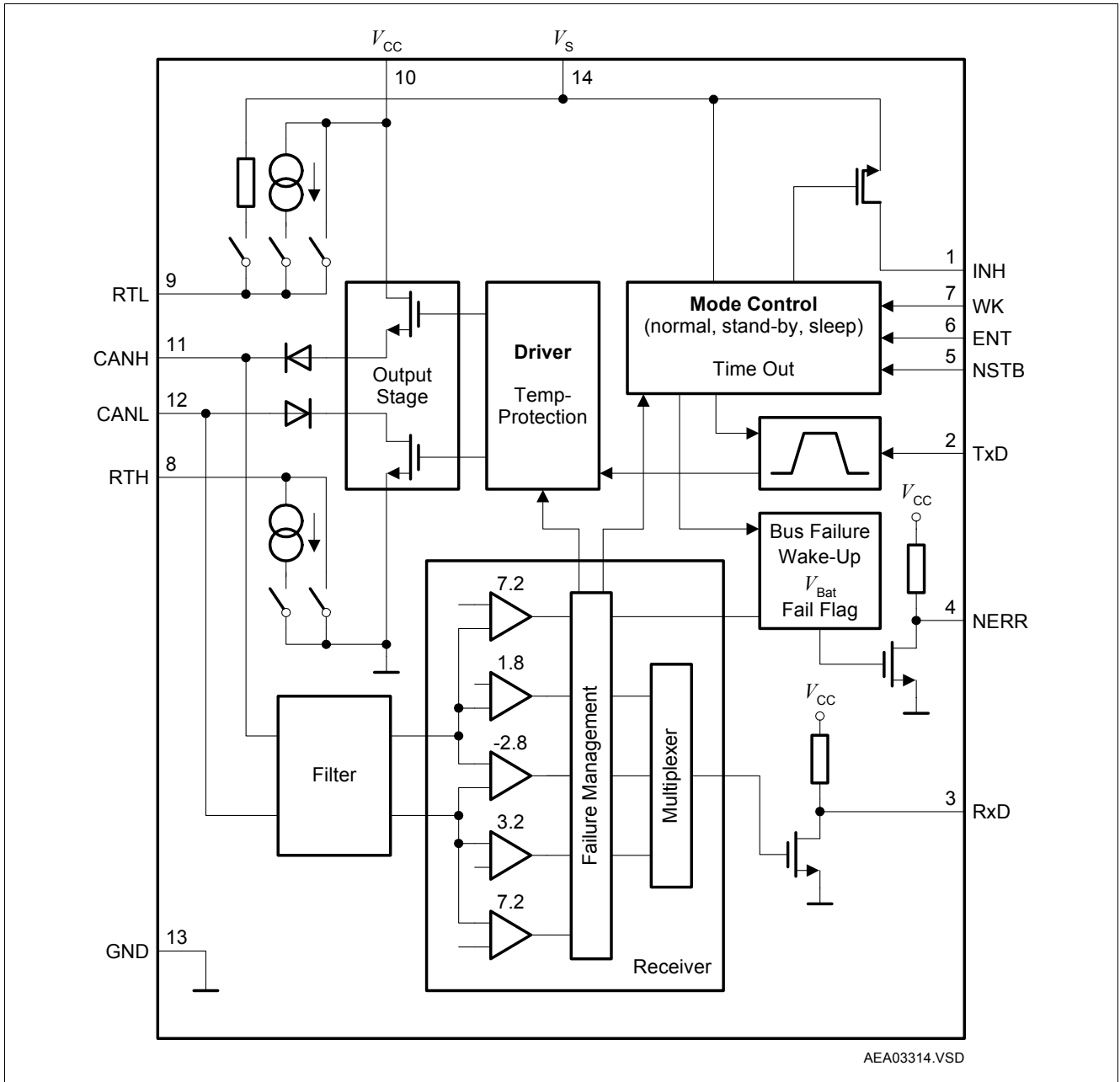

Figure 1 Block Diagram

## 2.1 Circuit Description

The CAN transceiver IFX1054G works as the interface between the CAN protocol controller and the physical CAN bus-lines. **Figure 2** shows the principle configuration of a CAN network.

The IFX1054G is optimized for low-speed data transmission (up to 125 kBaud) in industrial applications.

In Normal operation mode a differential signal is transmitted / received. When bus wiring failures are detected the device automatically switches in a dedicated single-wire mode to maintain communication.

While no data is transferred, the power consumption can be minimized by multiple low power operation modes. Further a Receive - Only mode is implemented.

To reduce radiated electromagnetic emission (EME) the dynamic slopes of the CANL and CANH signals are both limited and symmetric. This allows the use of an unshielded twisted or parallel pair of wires for the bus. During single-wire transmission (one of the bus lines is affected by a bus line failure) the EME performance of the system is degraded from the differential mode.

In case the transmission data input TxD is permanently dominant, both, the CANH and CANL transmitting stage are disabled after a certain delay time. This is necessary to prevent the bus from being blocked by a defective protocol unit or short to GND at the TxD input.

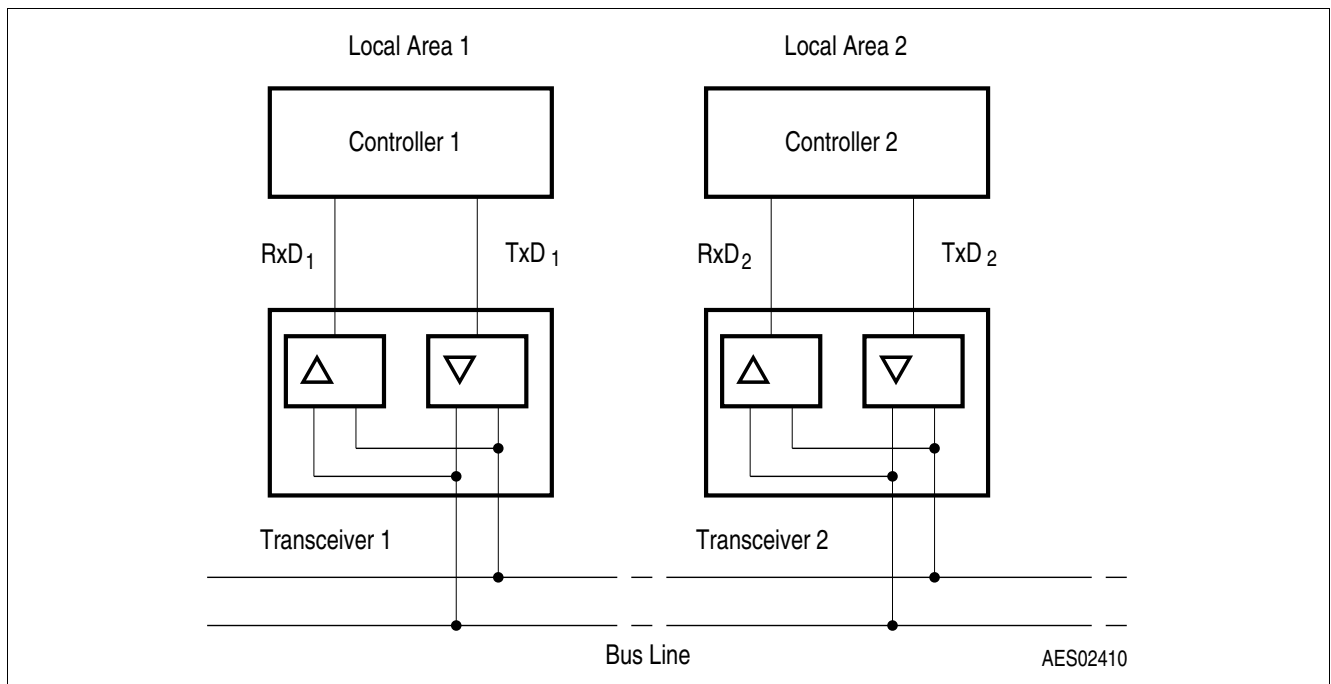

Figure 2 CAN Network Example

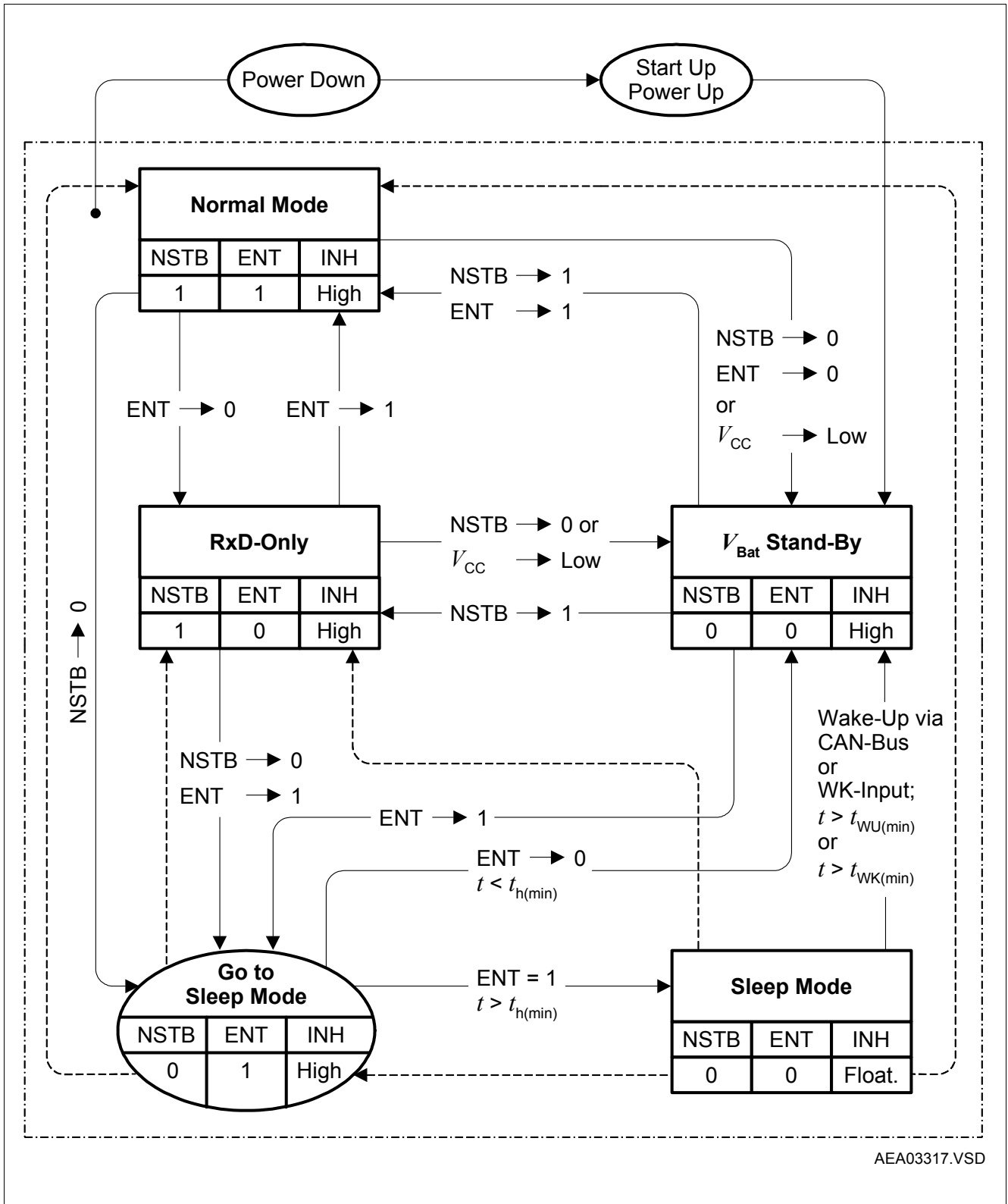

Figure 3 State Diagram

## 3 Pin Configuration

### 3.1 Pin Assignment

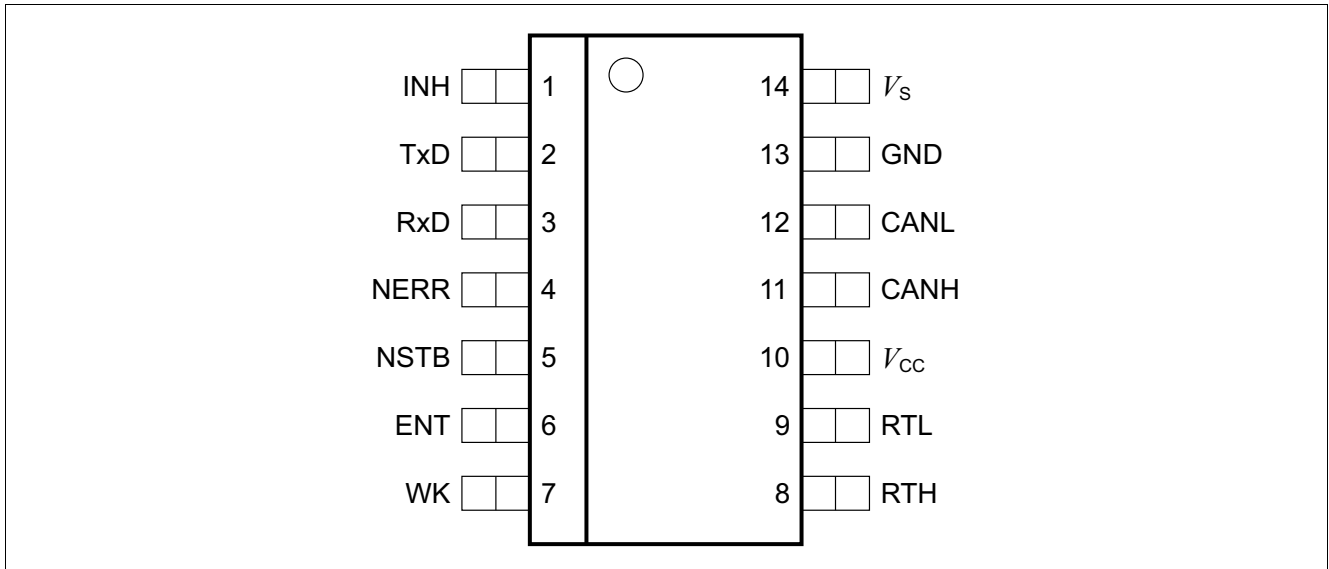

Figure 4 Pin Configuration

### 3.2 Pin Definitions and Functions

Pin	Symbol	Function
1	INH	<b>Inhibit output;</b> for controlling an external voltage regulator
2	TxD	<b>Transmit data input;</b> integrated pull - up, LOW: bus becomes dominant, HIGH: bus becomes recessive
3	RxD	<b>Receive data output;</b> integrated pull - up, LOW: bus is dominant, HIGH: bus is recessive
4	NERR	<b>Error flag output;</b> integrated pull - up, LOW: bus error (in Normal operation mode), further functions see <a href="#">Table 1</a>
5	NSTB	<b>Not stand-by input;</b> digital control input to select operation modes, see <a href="#">Figure 3</a>
6	ENT	<b>Enable transfer input;</b> digital control input to select operation modes, see <a href="#">Figure 3</a>
7	WK	<b>Wake - Up input;</b> if level of V <sub>WAKE</sub> changes the device indicates a Wake - up from low power mode by switching the RxD output LOW and switching the INH output HIGH (in Sleep mode), see <a href="#">Table 1</a>
8	RTH	<b>Termination resistor output;</b> connected to CANH bus-line via termination resistor (500 Ω < R <sub>RTH</sub> < 16 kΩ), controlled by internal failure management
9	RTL	<b>Termination resistor output;</b> connected to CANL bus-line via termination resistor (500 Ω < R <sub>RTL</sub> < 16 kΩ), controlled by internal failure and mode management
10	V <sub>CC</sub>	<b>Supply voltage input;</b> +5 V, block to GND directly at the IC with ceramic capacitor
11	CANH	<b>CAN bus line H;</b> HIGH: dominant state
12	CANL	<b>CAN bus line L;</b> LOW: dominant state
13	GND	<b>Ground</b>
14	V <sub>S</sub>	<b>Voltage supply input;</b> block to GND directly at the IC with ceramic capacitor



## 4 Operation Modes, Wake - Up

In addition to the Normal operation mode, the IFX1054G offers a Receive - Only mode as well as two Low - Power operation modes to save power during periods that do not require communication on the CAN bus: Sleep mode,  $V_{BAT}$  Stand - By mode (see [Table 1](#) and [Figure 2](#)). Via the control input pins NSTB and ENT the operation modes are selected by the microcontroller. In the Low - Power modes neither receiving nor transmitting of messages is possible.

In Sleep operation mode the lowest power consumption is achieved. In order to minimize the overall current consumption of the ECU (electronic control unit) the external voltage regulator (5 V supply) is deactivated by the INH output in this mode, when connected. For that purpose the INH output is switched to high impedance. In parallel the CANL line is pulled - up to the battery supply voltage via the RTL output and the pull - up paths at the input pins TxD and RxD are disabled from the internal supply.

To enter the Sleep operation mode the transition “Go - to - Sleep” has to be selected ([Figure 2](#)) for a minimum time  $t_{h(min)}$ . After the minimum hold time  $t_{h(min)}$  the Sleep mode can be actively selected. Otherwise the IFX1054G will automatically fall in Sleep mode because of the not powered microcontroller.

On a Wake - Up request either by bus line activities or via the WK input, the transceiver is automatically set in  $V_{BAT}$  Stand - By mode. Now the voltage regulator (5 V supply) is enabled by the INH output. The WK input reacts to both, transition from high to low voltage level as well as the other way round. To avoid faulty Wake - Up's due to transients on the bus lines or the WK input circuitry respectively, a certain filter time is implemented. As soon as  $V_{CC}$  is provided, the Wake - Up request is monitored on both, the NERR and RxD outputs, by setting them low. Upon this the microcontroller can activate the Normal operation mode by setting the control inputs NSTB and ENT high.

The  $V_{BAT}$  Stand - By mode corresponds to the Sleep mode, but a voltage regulator connected to the INH output will remain active. Wake - Up requests via the WK pin or the bus lines are immediately reported to the microcontroller by setting RxD and NERR low. A power - on condition ( $V_{BAT}$  pin is supplied) automatically switches the IFX1054G to  $V_{BAT}$  Stand - By mode.

In the Receive - Only mode data on the CAN-bus is transferred to the RxD output, but both output stages, CANH as well as CANL are disabled. This means that data at the TxD input is not transmitted to the CAN bus. This mode is useful in combination to a dedicated network - management software that allows separate diagnosis for all nodes.

A Wake - Up request in the Receive - Only mode is only reported at the RxD-output. The NERR output in this mode is used to indicate a battery fail condition. When entering the Normal mode the  $V_{BAT}$ -flag is reset and the NERR output becomes high again. This feature is useful e.g. when changing the ECU and therefore a presetting routine of the microcontroller has to be started.

If either of the supply voltages drops below the specified limits, the transceiver is automatically switched to  $V_{BAT}$  Stand - By mode or power - down mode respectively.

**Table 1 Truth Table of the CAN Transceiver**

NSTB	ENT	Mode	INH	NERR	RxD	RTL
0	0	$V_{BAT}$ Stand - By mode <sup>1)</sup>	$V_{BAT}$	active LOW Wake - Up interrupt if $V_{CC}$ is present		switched to $V_{BAT}$
0	0	Sleep mode <sup>2)</sup>	floating			switched to $V_{BAT}$
0	1	Go - to - Sleep command	becomes floating			switched to $V_{BAT}$
1	0	Receive - Only mode	$V_{BAT}$	active LOW $V_{BAT}$ Power - On flag <sup>3)</sup>	HIGH = recessive receive data; LOW = dominant receive data	switched to $V_{CC}$
1	1	Normal mode	$V_{BAT}$	active LOW bus error flag	HIGH = recessive receive data; LOW = dominant receive data	switched to $V_{CC}$

1) Wake - Up interrupts are released when entering Normal operation mode.

2) If Go - to - Sleep command was used before, ENT may turn LOW as  $V_{CC}$  drops, without affecting internal functions.

3)  $V_{BAT}$  Power - On flag will be reseted when entering Normal operation mode.

#### 4.1 Bus Failure Management

The IFX1054G detects the bus failures as described in [Table 2](#), and automatically switches to a dedicated CANH or CANL single wire mode to maintain data transmission if necessary. Therefore, the device is equipped with one differential receiver and 4 single ended receivers, two for each bus line. To avoid false triggering by external RF influences the single wire modes are only activated after a certain delay time. As soon as the bus failure disappears the transceiver switches back to differential mode after another time delay. Bus failures are indicated in the Normal operation mode by setting the NERR output low.

The differential receiver threshold is typ. -3.1 V. This ensures correct reception in the Normal operation mode as well as in the failure cases 1, 2 and 4 with a noise margin as high as possible. For these failures, further failure management is not necessary. Detection of the failure cases 1, 2, 3a and 4 is only possible when the bus is dominant. Nevertheless, they are reported on the NERR output until transmission of the next CAN word on the bus begins.

When one of the bus failures 3, 5, 6, 6a and 7 is detected, the defective bus wire is disabled by switching off the affected bus termination and the respective output stage. A Wake - Up from Sleep mode via the bus is possible either via a dominant CANH or CANL line. This ensures that a Wake - Up is possible even if one of the failures 1 to 7 occurs.

**Table 2 CAN Bus-line Failures**

Failure #	Failure Description
1	CANL line interrupted
2	CANH line interrupted
3	CANL line shorted to $V_{BAT}$
3a	CANL line shorted to $V_{CC}$
4	CANH line shorted to GND
5	CANL line shorted to GND
6	CANH line shorted to $V_{BAT}$

**Table 2 CAN Bus-line Failures**

Failure #	Failure Description
6a	CANH line shorted to $V_{CC}$
7	CANL line shorted to CANH line

A current limiting circuit protects the CAN transceiver output stages from damage by short-circuit to positive and negative battery voltages. The CANH and CANL pins are protected against electrical transients.

The transmitter output stages generate the majority of the power dissipation. Therefore they are disabled if the junction temperature exceeds the maximum value. This effectively reduces power dissipation, and hence will lead to a lower chip temperature, while other parts of the IC can remain operating. In temperature shut - down condition the IFX1054G is still able to receive CAN-bus messages.

## 4.2 Application Hints

**Table 3 Not Needed Pins**

Pin Symbol	Recommendation
INH	Leave open
NERR	Leave open
NSTB	Connect to $V_{CC}$
ENT	Connect to $V_{CC}$
WK	Connect to $V_{BAT}$ , connect to GND: increases current consumption by approx. 5 $\mu$ A

## 5 Absolute Maximum Ratings

**Table 4 Absolute Maximum Ratings**

Parameter	Symbol	Limit Values		Unit	Notes
		Min.	Max.		
Input voltage at $V_{BAT}$	$V_S$	-0.3	40	V	–
Logic supply voltage $V_{CC}$	$V_{CC}$	-0.3	6	V	–
Input voltage at TxD, RxD, NERR, NSTB and ENT	$V_{IN}$	-0.3	$V_{CC} + 0.3$	V	–
Input voltage at CANH and CANL	$V_{BUS}$	-40	40	V	–
Transient voltage at CANH and CANL	$V_{BUS}$	-150	100	V	1)
Input voltage at WK	$V_{WK}$	-40	40	V	–
Input voltage at INH	$V_{INH}$	-0.3	$V_{BAT} + 0.3$	V	–
Input voltage at RTH and RTL	$V_{RTH/L}$	-0.3	40	V	–
Junction temperature	$T_j$	-40	160	°C	–
Storage temperature	$T_{stg}$	-55	155	°C	–
Electrostatic discharge voltage at pin CANH, CANL, RTH, RTL, $V_{BAT}$	$V_{esd}$	-4	4	kV	2)
Electrostatic discharge voltage at any other pin	$V_{esd}$	-2	2	kV	2)

1) See ISO 7637

2) Human body model: equivalent to discharging a 100 pF capacitor through a 1.5 kΩ resistor.

*Note: Stresses above those listed here may cause permanent damage to the device. Exposure to absolute maximum rating conditions for extended periods may affect device reliability.*

### 5.1 Functional Range

**Table 5 Functional Range**

Parameter	Symbol	Limit Values		Unit	Notes
		Min.	Max.		
Logic input voltage	$V_{CC}$	4.75	5.25	V	–
Battery input voltage	$V_S$	5.7	27	V	–
Termination resistances at RTL and RTH	$R_{RTL/H}$	0.5	16	kΩ	–
Junction temperature	$T_j$	-40	150	°C	–
<b>Thermal Resistance</b>					
Junction ambient	$R_{thja}$	–	120	K/W	–
<b>Thermal Shutdown</b>					
Junction temperature	$T_{jSH}$	160	200	°C	10 °C hyst.
<b>Wake Input Voltage</b>					
Wake input voltage	$V_{WK}$	-0.3	27	V	–

*Note: In the operating range, the functions given in the circuit description are fulfilled.*

## 6 Electrical Characteristics

**Table 6 Static Characteristics**

4.75 V ≤ V<sub>CC</sub> ≤ 5.25 V; 6 V ≤ V<sub>S</sub> ≤ 27 V; normal operation mode; -40 ≤ T<sub>j</sub> ≤ +125 °C (unless otherwise specified). All voltages are defined with respect to ground. Positive current flowing into the IC.

Parameter	Symbol	Limit Values			Unit	Notes
		Min.	Typ.	Max.		
<b>Supplies V<sub>CC</sub>, V<sub>S</sub></b>						
Supply current	I <sub>CC</sub>	-	3.5	10.0	mA	Recessive; TxD = V <sub>CC</sub>
		-	6.5	10	mA	Dominant; TxD = 0 V; no load
Supply current (Receive - Only mode)	I <sub>CC</sub>	-	3.5	10.0	mA	-
Supply current (V <sub>BAT</sub> Stand - By)	I <sub>CC</sub>	-	25	55	μA	V <sub>CC</sub> = 5 V;
	I <sub>S</sub>	-	30	50	μA	V <sub>S</sub> = 12 V
Supply current (V <sub>BAT</sub> Stand - By)	I <sub>CC</sub> + I <sub>S</sub>	-	55	85	μA	V <sub>CC</sub> = 5 V; V <sub>S</sub> = 12 V T <sub>j</sub> = 25 °C
Supply current (Sleep operation mode)	I <sub>S</sub>	-	50	70	μA	V <sub>CC</sub> = 0 V; V <sub>S</sub> = 12 V
Supply current (Sleep operation mode)	I <sub>S</sub>	-	50	65	μA	V <sub>CC</sub> = 0 V; V <sub>S</sub> = 12 V T <sub>j</sub> = 25 °C
Battery voltage for setting power - on flag	V <sub>S</sub>	-	1	3.5	V	-
<b>Receiver Output RxD and Error Detection Output NERR</b>						
HIGH level output voltage (pin NERR)	V <sub>OH</sub>	V <sub>CC</sub> - 0.9	-	V <sub>CC</sub>	V	I <sub>0</sub> = -100 μA
HIGH level output voltage (pin RxD)	V <sub>OH</sub>	V <sub>CC</sub> - 0.9	-	V <sub>CC</sub>	V	I <sub>0</sub> = -250 μA
LOW level output voltage	V <sub>OL</sub>	0	-	0.9	V	I <sub>0</sub> = 1.25 mA
<b>Transmission Input TxD, not Stand-By NSTB and Enable Transfer ENT</b>						
HIGH level input voltage	V <sub>IH</sub>	0.7 × V <sub>CC</sub>	-	V <sub>CC</sub> + 0.3	V	-
LOW level input voltage	V <sub>IL</sub>	-0.3	-	0.3 × V <sub>CC</sub>	V	-
HIGH level input current (pins NSTB and ENT)	I <sub>IH</sub>	-	20	80	μA	V <sub>i</sub> = 4 V
LOW level input current (pins NSTB and ENT)	I <sub>IL</sub>	0.7	6	-	μA	V <sub>i</sub> = 1 V
HIGH level input current (pin TxD)	I <sub>IH</sub>	-150	-30	-5	μA	V <sub>i</sub> = 4 V
LOW level input current (pin TxD)	I <sub>IL</sub>	-600	-300	-40	μA	V <sub>i</sub> = 1 V
Forced battery voltage stand-by mode (fail safe)	V <sub>CC</sub>	2.75	-	4.5	V	-



**Electrical Characteristics**
**Table 6 Static Characteristics (cont'd)**

4.75 V  $\leq V_{CC} \leq 5.25$  V; 6 V  $\leq V_S \leq 27$  V; normal operation mode;  $-40 \leq T_j \leq +125$  °C (unless otherwise specified). All voltages are defined with respect to ground. Positive current flowing into the IC.

Parameter	Symbol	Limit Values			Unit	Notes
		Min.	Typ.	Max.		
<b>Wake - Up input WK</b>						
Input current	$I_{IL}$	-3	-2	-1	$\mu$ A	$V_{WK} = 0$ V
Wake - Up threshold voltage	$V_{WK(min)}$	2.2	3.0	3.9	V	$V_{NSTB} = 0$ V
<b>Inhibit Output INH</b>						
HIGH level voltage drop $\Delta V_H = V_S - V_{INH}$	$\Delta V_H$	–	0.1	0.8	V	$I_{INH} = -0.18$ mA
Leakage current	$I_{INH,ik}$	-5.0	–	5.0	$\mu$ A	sleep operation mode; $V_{INH} = 0$ V
<b>Bus Lines CANL, CANH</b>						
Differential receiver recessive-to-dominant threshold voltage	$V_{dRxD(rd)}$	-3.6	-3.1	-2.6	V	$V_{CC} = 5.0$ V
Differential receiver dominant-to-recessive threshold voltage	$V_{dRxD(dr)}$	-3.6	-3.1	-2.6	V	$V_{CC} = 5.0$ V
CANH recessive output voltage	$V_{CANH,r}$	0.10	0.15	0.30	V	TxD = $V_{CC}$ ; $R_{RTH} < 4$ k $\Omega$
CANL recessive output voltage	$V_{CANL,r}$	$V_{CC} - 0.2$	–	–	V	TxD = $V_{CC}$ ; $R_{RTL} < 4$ k $\Omega$
CANH dominant output voltage	$V_{CANH,d}$	$V_{CC} - 1.4$	$V_{CC} - 1.0$	$V_{CC}$	V	TxD = 0 V; $V_{CC} = 5$ V; $R_L = 100\Omega$
CANL dominant output voltage	$V_{CANL,d}$	–	1.0	1.4	V	TxD = 0 V; $V_{CC} = 5$ V; $R_L = 100\Omega$
CANH output current	$I_{CANH}$	-110	-80	-50	mA	$V_{CANH} = 0$ V; TxD = 0 V
		-5	0	5	$\mu$ A	Sleep operation mode; $V_{CANH} = 12$ V
CANL output current	$I_{CANL}$	50	80	110	mA	$V_{CANL} = 5$ V; TxD = 0 V
		-5	0	5	$\mu$ A	Sleep operation mode; $V_{CANL} = 0$ V; $V_S = 12$ V
Voltage detection threshold for short-circuit to battery voltage on CANH and CANL	$V_{det(th)}$	6.5	7.3	8.0	V	–
CANH Wake - Up voltage threshold	$V_{CANH,wu}$	1.1	2.2	2.5	V	–
CANL Wake - Up voltage threshold	$V_{CANL,wu}$	2.5	3.1	3.9	V	–
CANH single-ended receiver threshold	$V_{CANH}$	1.5	1.8	2.3	V	failure cases 3, 5 and 7; $V_{CC} = 5$ V

**Electrical Characteristics**
**Table 6 Static Characteristics (cont'd)**

4.75 V  $\leq V_{CC} \leq 5.25$  V; 6 V  $\leq V_S \leq 27$  V; normal operation mode;  $-40 \leq T_j \leq +125$  °C (unless otherwise specified). All voltages are defined with respect to ground. Positive current flowing into the IC.

Parameter	Symbol	Limit Values			Unit	Notes
		Min.	Typ.	Max.		
CANL single-ended receiver threshold	$V_{CANL}$	2.8	3.1	3.5	V	failure case 6 and 6a; $V_{CC} = 5$ V
Difference of Wake - Up threshold	$V_{diff,wu}$	0.8	–	–	V	–
CANL leakage current	$I_{CANL,ik}$	-5	0	5	$\mu$ A	$V_{CC} = 0$ V; $V_S = 0$ V; $V_{CANL} = 12$ V; $T_j < 85$ °C
CANH leakage current	$I_{CANH,ik}$	-5	0	5	$\mu$ A	$V_{CC} = 0$ V; $V_S = 0$ V; $V_{CANH} = 5$ V; $T_j < 85$ °C

**Termination Outputs RTL, RTH**

RTL to $V_{CC}$ switch - on resistance	$R_{RTL}$	–	20	95	$\Omega$	$I_o = -10$ mA
RTL to BAT switch series resistance	$R_{oRTL}$	8	15	30	k $\Omega$	$V_{BAT}$ Stand - By or Sleep operation mode
RTH to ground switch - on resistance	$R_{RTH}$	–	40	95	$\Omega$	$I_o = 10$ mA
RTH output voltage	$V_{oRTH}$	–	0.7	1.0	V	$I_o = 1$ mA; low power mode
RTH pull - down current	$I_{RTH,pd}$	40	75	120	$\mu$ A	failure cases 6 and 6a
RTL pull - up current	$I_{RTL,pu}$	-120	-75	-40	$\mu$ A	failure cases 3, 5 and 7
RTH leakage current	$I_{RTH,ik}$	-5	0	5	$\mu$ A	$V_{CC} = 0$ V; $V_S = 0$ V; $V_{RTH} = 5$ V; $T_j < 85$ °C
RTL leakage current	$I_{RTL,ik}$	-10	0	10	$\mu$ A	$V_{CC} = 0$ V; $V_S = 0$ V; $V_{RTL} = 12$ V; $T_j < 85$ °C

**Electrical Characteristics**
**Table 7 Dynamic Characteristics**

4.75 V ≤ V<sub>CC</sub> ≤ 5.25 V; 6 V ≤ V<sub>S</sub> ≤ 27 V; normal operation mode; -40 ≤ T<sub>j</sub> ≤ +125 °C (unless otherwise specified). All voltages are defined with respect to ground. Positive current flowing into the IC.

Parameter	Symbol	Limit Values			Unit	Notes
		Min.	Typ.	Max.		
CANH and CANL bus output transition time recessive-to-dominant	t <sub>rd</sub>	0.6	1.2	2.4	μs	10% to 90%; C <sub>1</sub> = 10 nF; C <sub>2</sub> = 0; R <sub>1</sub> = 100 Ω
CANH and CANL bus output transition time dominant-to-recessive	t <sub>dr</sub>	0.3	0.6	1.3	μs	10% to 90%; C <sub>1</sub> = 1 nF; C <sub>2</sub> = 0; R <sub>1</sub> = 100 Ω
Minimum dominant time for Wake - Up via CANL or CANH	t <sub>wu(min)</sub>	8	25	40	μs	Stand - By modes; V <sub>S</sub> = 12 V
Minimum Wake - Up time on pin WK	t <sub>wk(min)</sub>	8	25	50	μs	Low power modes; V <sub>S</sub> = 12 V
Failure cases 3, 6 detection time	t <sub>fail</sub>	20	40	80	μs	Normal operation mode
Failure case 6a detection time		2	4	8	ms	Normal operation mode
Failure cases 5, 7 detection time		1.0	2.0	4.0	ms	Normal operation mode
Failure cases 5, 6, 6a, 7 recovery time		20	40	80	μs	Normal operation mode
Failure cases 3 recovery time		250	500	750	μs	Normal operation mode
Failure cases 5, 7 detection time		0.4	1.0	2.4	ms	Stand - By mode; V <sub>S</sub> = 12 V
Failure cases 5, 7 recovery time		0.4	1.0	2.4	ms	Stand - By mode; V <sub>S</sub> = 12 V
Failure cases 6, 6a detection time		0.8	4.0	8.0	ms	Stand - By mode; V <sub>S</sub> = 12 V
Failure cases 6, 6a recovery time		0.4	1.0	2.4	ms	Stand - By mode; V <sub>S</sub> = 12 V
Propagation delay TxD-to-RxD LOW (recessive to dominant)		t <sub>PD(L)</sub>	–	1.3	2.4	μs
	–		1.5	2.4	μs	C <sub>1</sub> = C <sub>2</sub> = 3.3 nF; R <sub>1</sub> = 100 Ω; no bus failure and failure cases 1, 2, 3a, 4
	–		1.6	2.5	μs	C <sub>1</sub> = 100 pF; C <sub>2</sub> = 0; R <sub>1</sub> = 100 Ω; bus failure cases 3, 5, 6, 6a
	–		1.8	2.6	μs	C <sub>1</sub> = C <sub>2</sub> = 3.3 nF; R <sub>1</sub> = 100 Ω; bus failure cases 3, 5, 6, 6a

**Electrical Characteristics**
**Table 7 Dynamic Characteristics (cont'd)**

4.75 V  $\leq V_{CC} \leq 5.25$  V; 6 V  $\leq V_S \leq 27$  V; normal operation mode;  $-40 \leq T_j \leq +125$  °C (unless otherwise specified). All voltages are defined with respect to ground. Positive current flowing into the IC.

Parameter	Symbol	Limit Values			Unit	Notes
		Min.	Typ.	Max.		
Propagation delay TxD-to-RxD HIGH (dominant to recessive)	$t_{PD(H)}$	–	1.2	2.4	$\mu$ s	$C_1 = 100$ pF; $C_2 = 0$ ; $R_1 = 100$ $\Omega$ ; no failures and bus failure cases 1, 2, 3a, 4
		–	2.5	3.5	$\mu$ s	$C_1 = C_2 = 3.3$ nF; $R_1 = 100$ $\Omega$ ; no bus failure and failure cases 1, 2, 3a, 4
Propagation delay TxD-to-RxD HIGH (dominant to recessive)	$t_{PD(H)}$	–	1.0	2.1	$\mu$ s	$C_1 = 100$ pF; $C_2 = 0$ ; $R_1 = 100$ $\Omega$ ; bus failure cases 3, 5, 6, 6a
		–	1.5	2.6	$\mu$ s	$C_1 = C_2 = 3.3$ nF; $R_1 = 100$ $\Omega$ ; bus failure cases 3, 5, 6, 6a
Minimum hold time to go sleep command	$t_{h(min)}$	15	30	60	$\mu$ s	–
Edge-count difference (falling edge) between CANH and CANL for failure cases 1, 2, 3a, 4 detection NERR becomes LOW	$n_e$	–	4	–	–	Normal operating mode
Edge-count difference (rising edge) between CANH and CANL for failure cases 1, 2, 3a, 4 recovery		–	2	–	–	Normal operating mode
TxD permanent dominant disable time	$t_{TxD}$	1.3	2.0	3.5	ms	–

## 7 Application Information

Note: The following information is given as a hint for the implementation of the device only and shall not be regarded as a description or warranty of a certain functionality, condition or quality of the device.

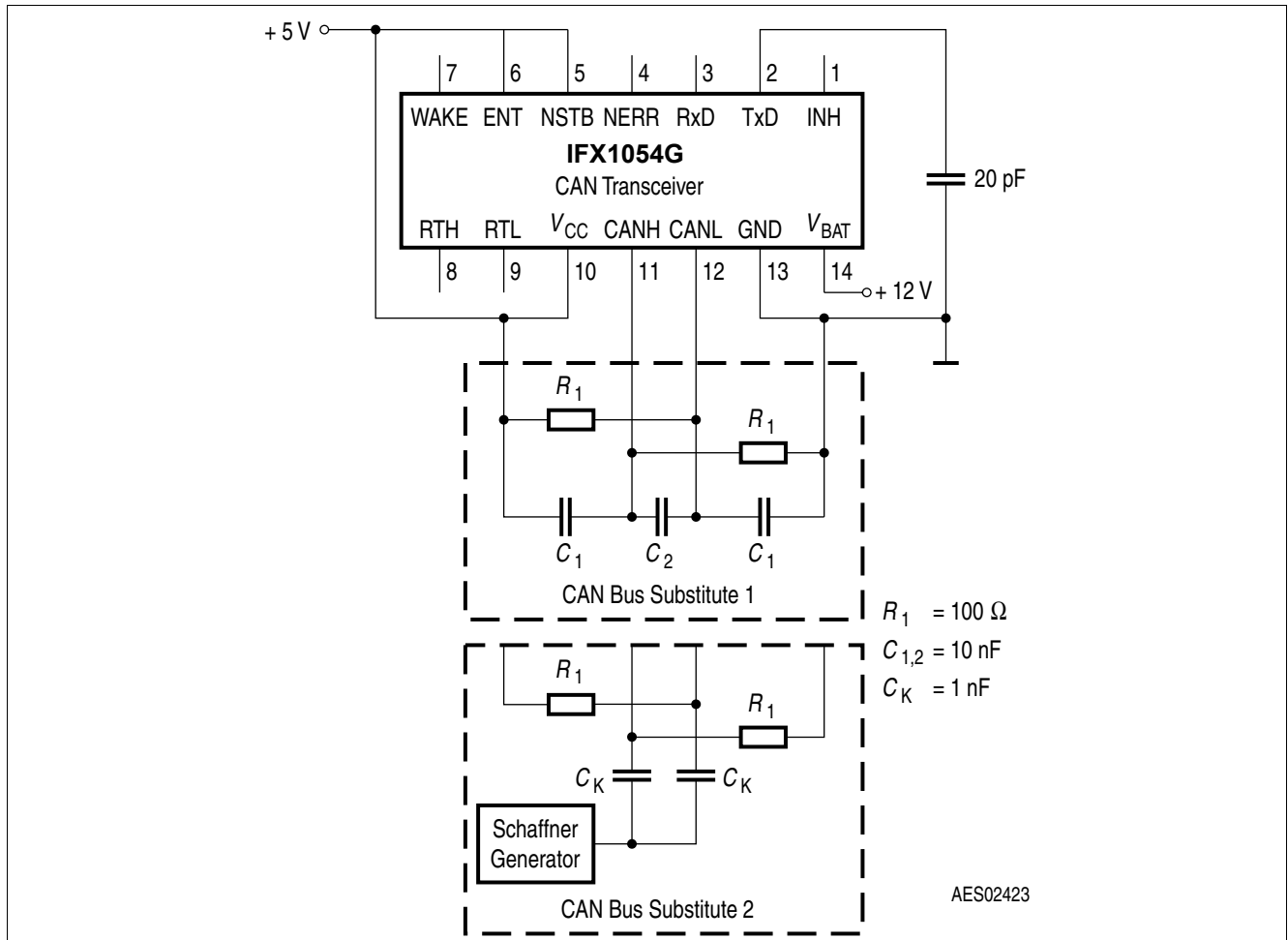

**Figure 5 Test Circuit**

For isolated testing the CAN Bus Substitute 1 is connected to the CAN Transceiver (see [Figure 5](#)). The capacitors  $C_{1-2}$  simulate the cable. Allowed minimum values of the termination resistors  $R_{RTH}$  and  $R_{RTL}$  are 500  $\Omega$ . Electromagnetic interference on the bus lines is simulated by switching to CAN Bus Substitute 2. The waves of the applied transients will be in accordance with ISO 7637 part 1, test 1, test pulses 1, 2, 3a and 3b.



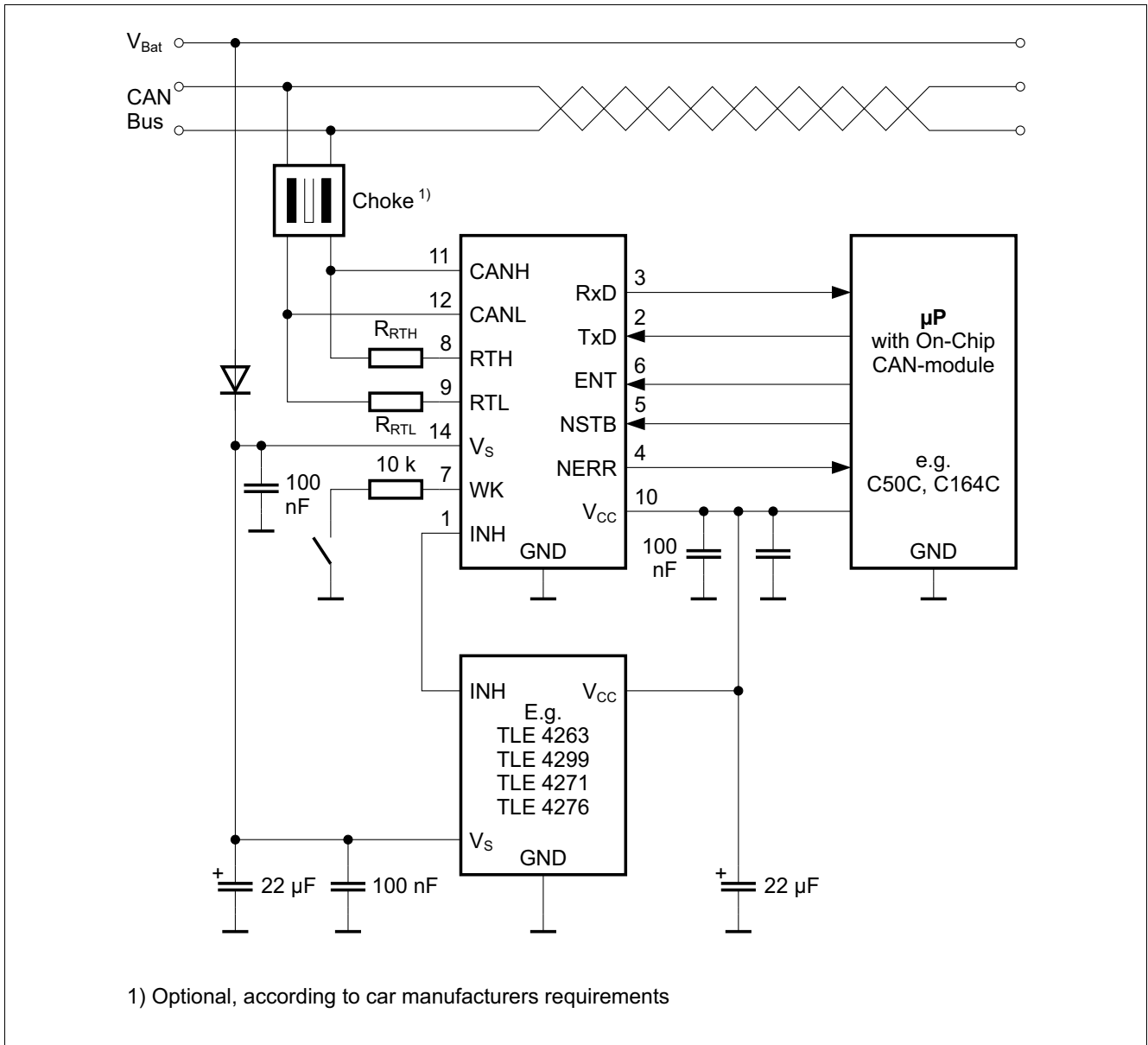

**Figure 6 Application Example**

*Note: This is a very simplified example of an application circuit. The function must be verified in the real application.*

**7.1 Further Application Information**

- Please contact us for information regarding the Pin FMEA.
- Existing Application Note
- For further information you may contact: <http://www.infineon.com/>

## 8 Package Outlines

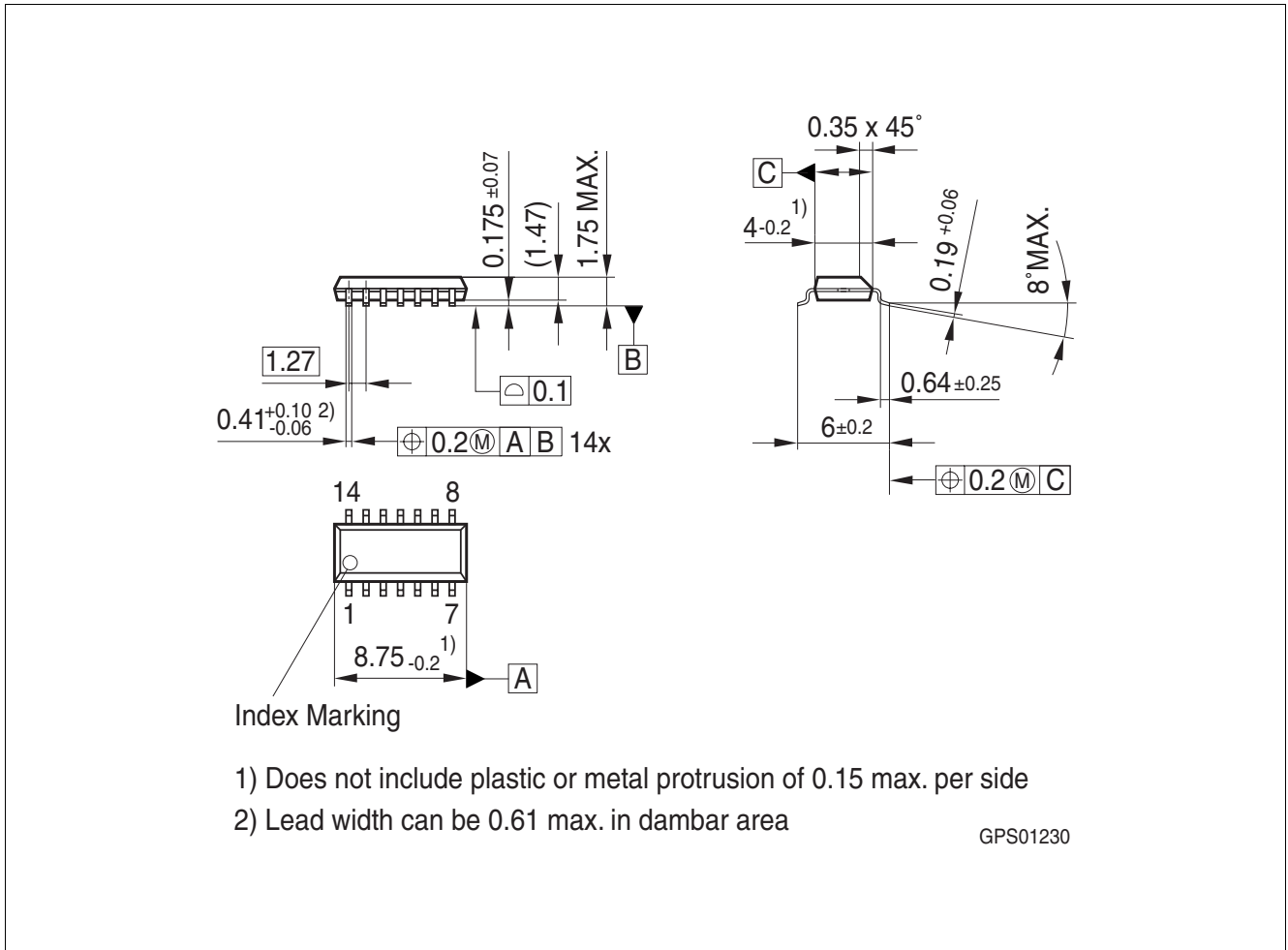

Figure 7 PG-DSO-14

### Green Product (RoHS compliant)

To meet the world-wide customer requirements for environmentally friendly products and to be compliant with government regulations the device is available as a green product. Green products are RoHS-Compliant (i.e. Pb-free finish on leads and suitable for Pb-free soldering according to IPC/JEDEC J-STD-020).

For further information on alternative packages, please visit our website:  
<http://www.infineon.com/packages>.

Dimensions in mm

## 9 Revision History

Revision	Date	Changes
1.0	2009-05-12	Initial Data sheet

**Edition 2009-05-12**

**Published by  
Infineon Technologies AG  
81726 Munich, Germany**

**© 2009 Infineon Technologies AG  
All Rights Reserved.**

### **Legal Disclaimer**

The information given in this document shall in no event be regarded as a guarantee of conditions or characteristics. With respect to any examples or hints given herein, any typical values stated herein and/or any information regarding the application of the device, Infineon Technologies hereby disclaims any and all warranties and liabilities of any kind, including without limitation, warranties of non-infringement of intellectual property rights of any third party.

### **Information**

For further information on technology, delivery terms and conditions and prices, please contact the nearest Infineon Technologies Office ([www.infineon.com](http://www.infineon.com)).

### **Warnings**

Due to technical requirements, components may contain dangerous substances. For information on the types in question, please contact the nearest Infineon Technologies Office.

Infineon Technologies components may be used in life-support devices or systems only with the express written approval of Infineon Technologies, if a failure of such components can reasonably be expected to cause the failure of that life-support device or system or to affect the safety or effectiveness of that device or system. Life support devices or systems are intended to be implanted in the human body or to support and/or maintain and sustain and/or protect human life. If they fail, it is reasonable to assume that the health of the user or other persons may be endangered.