



Chipsmall Limited consists of a professional team with an average of over 10 year of expertise in the distribution of electronic components. Based in Hongkong, we have already established firm and mutual-benefit business relationships with customers from,Europe,America and south Asia,supplying obsolete and hard-to-find components to meet their specific needs.

With the principle of “Quality Parts,Customers Priority,Honest Operation,and Considerate Service”,our business mainly focus on the distribution of electronic components. Line cards we deal with include Microchip,ALPS,ROHM,Xilinx,Pulse,ON,Everlight and Freescale. Main products comprise IC,Modules,Potentiometer,IC Socket,Relay,Connector.Our parts cover such applications as commercial,industrial, and automotives areas.

We are looking forward to setting up business relationship with you and hope to provide you with the best service and solution. Let us make a better world for our industry!



Contact us

Tel: +86-755-8981 8866 Fax: +86-755-8427 6832

Email & Skype: info@chipsmall.com Web: www.chipsmall.com

Address: A1208, Overseas Decoration Building, #122 Zhenhua RD., Futian, Shenzhen, China



IsoLoop[®] Isolated CAN Evaluation Board

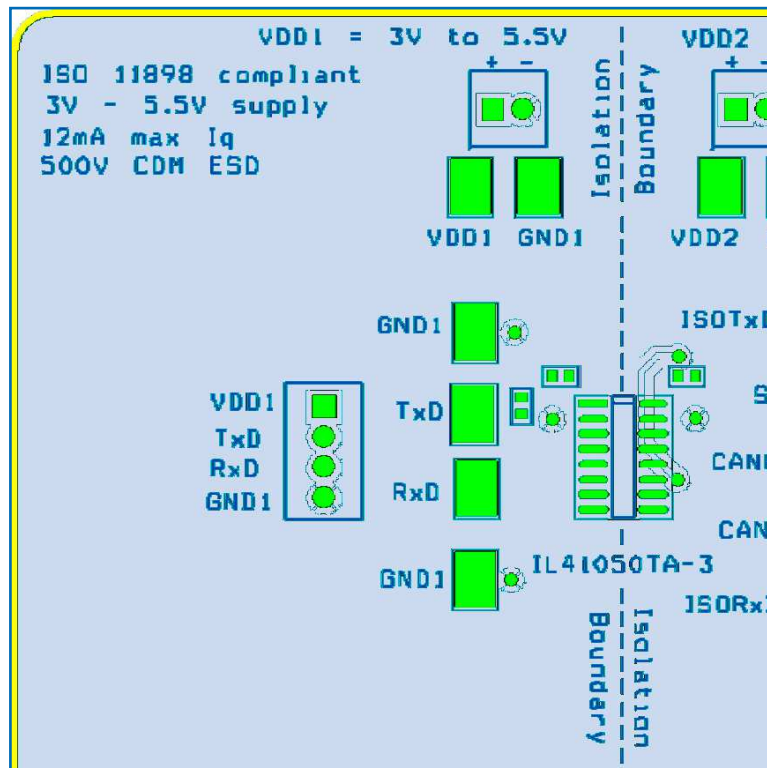

Board No.: IL41050-01

About This Evaluation Board

This Evaluation Board provides a complete isolated CAN node using the revolutionary IL41050TA-3E isolated transceiver.

The IL41050TA is a galvanically isolated, CAN (Controller Area Network) transceiver, designed as the interface between the CAN protocol controller and the physical bus. Advanced features facilitate reliable bus operation. Unpowered nodes do not disturb the bus, and a unique non-volatile programmable power-up feature prevents unstable nodes. The devices also have a hardware-selectable silent mode that disables the transmitter.

Designed for harsh CAN and DeviceNet environments, IL41050TA transceivers have transmit data dominant time-out, bus pin transient protection, a rugged Charged Device Model ESD rating, thermal shutdown protection, and short-circuit protection. Unique edge-triggered inputs improve noise performance.

Unlike optocouplers or other isolation technologies, IsoLoop isolators have virtually indefinite barrier life.

The Isolation Advantage

Battery fire caused by over or under charging of individual lithium ion cells is a major concern in multi-cell high voltage electric and hybrid vehicle batteries. To combat this, each cell is monitored for current flow, cell voltage, and in some advanced batteries, magnetic susceptibility. The IL41050 allows seamless connection of the monitoring electronics of every cell to a common CAN bus by electrically isolating inputs from outputs, effectively isolating each cell from all other cells. Cell status is then monitored via the CAN controller in the Battery Management System (BMS).

Another major advantage of isolation is the tremendous increase in noise immunity it affords the CAN node, even if the power source is a battery. Inductive drives and inverters can produce transient swings in excess of 20 kV/ μ s. The traditional, non-isolated CAN node provides some protection due to differential signaling and symmetrical driver/receiver pairs, but the IL41050 typically provides more than twice the dV/dt protection of a traditional CAN node.

Circuit Diagram

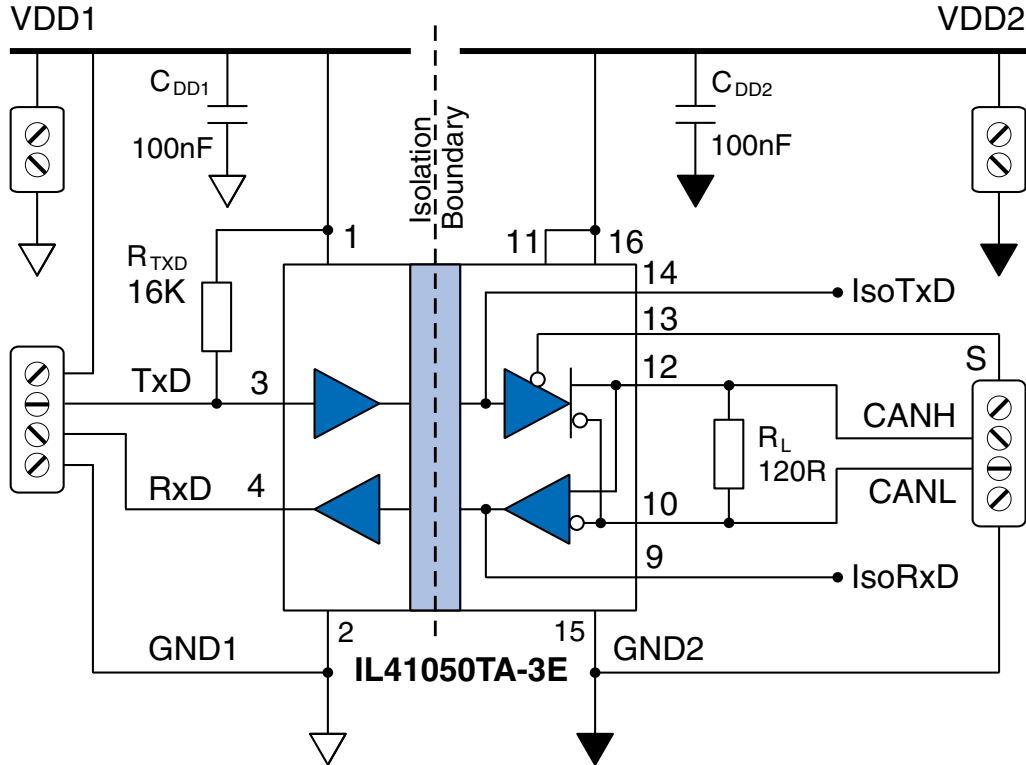

IL41050 TA-3E pin	Symbol	Description
1	V_{DD1}	V_{DD1} power supply
2	GND_1	V_{DD1} power supply ground return
3	TxD	Transmit Data input
4	RxD	Receive Data output
5	NC	No internal connection
6	NC	No internal connection
7	NC	No internal connection
8	NC	No internal connection
9	IsoRxD	Isolated RxD output (for test purposes only)
10	CANL	Low level CANbus line
11	V_{DD2}	V_{DD2} CAN I/O bus circuitry power supply input*
12	CANH	High level CANbus line
13	S	Mode select input (open or low for normal operation; high for silent mode)
14	IsoTxD	Isolated TxD output (for test purposes only)
15	GND_2	V_{DD2} power supply ground return
16	V_{DD2}	V_{DD2} isolation power supply input*

*Pin 11 is not internally connected to pin 16; both are connected to V_{DD2} in the PCA.

Specification Highlights and Quickstart

IL41050TA Specification Highlights:

- Fully compliant with the ISO 11898 CAN standard
- 3.0 V to 5.5 V input power supplies
- 12 mA maximum quiescent recessive supply current
- 70 mA maximum bus-side dynamic supply current
- ± 500 V CDM ESD
- 1 Mbps
- 2,500 V_{RMS} isolation (1 minute)
- 30 kV/ μ s transient immunity
- Silent mode to disable transmitter
- Unpowered nodes do not disturb the bus
- Edge triggered, non-volatile input improves noise performance
- Thermal shutdown protection
- Short-circuit protection for ground and bus power
- -55°C to $+125^{\circ}\text{C}$ operating temperature
- 0.15" and 0.3" and 16-pin JEDEC-standard SOIC packages
- UL1577 and IEC 61010-2001 approved

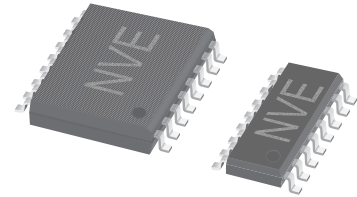

Quick Start:

- Connect V_{DD1} to a 3.3 V power supply and V_{DD2} to 5 V.
- Connect a 500 kHz signal generator to the “TxD” input.
- Verify the “Rx” and CAN outputs on an oscilloscope:

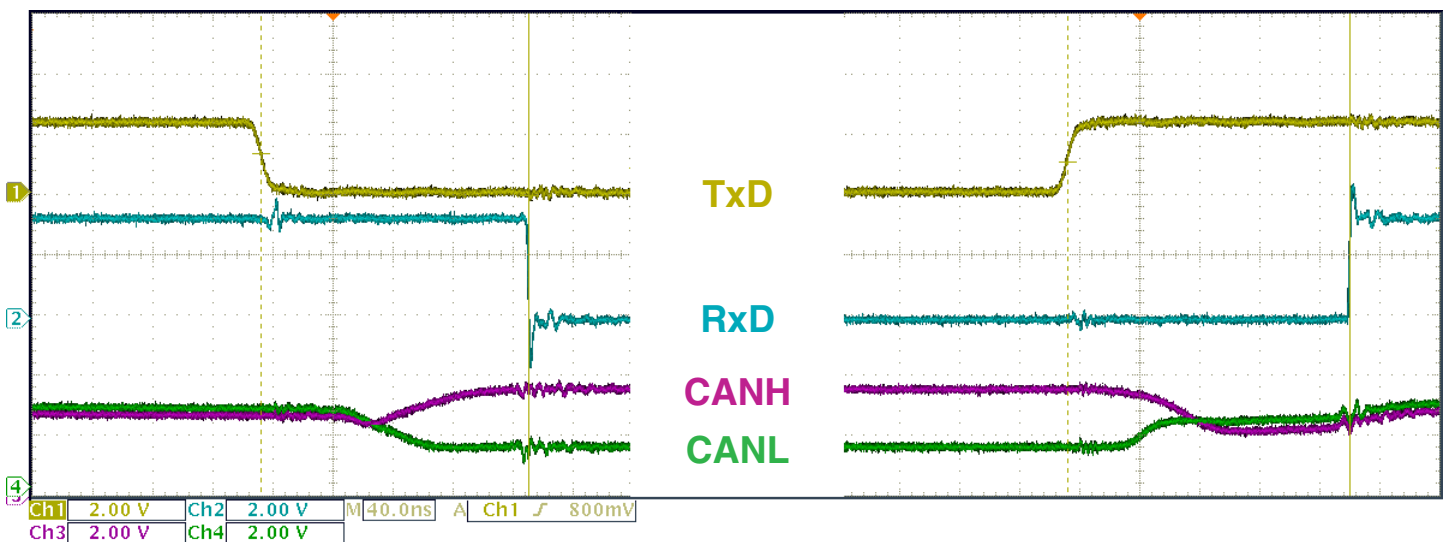

Visit www.IsoLoop.com for datasheets.

Application Information

Bus-Side Power Supply Pins

Both V_{DD2} power supply inputs (pins 11 and 16) must be connected to the bus-side power supply. Pin 11 powers the bus side of the CAN I/O circuitry, while pin 16 powers the bus-side isolation circuitry. For testing purposes, they are not internally connected, but the part will not operate without both pins powered, and operation without both pins powered can cause damage.

Power Supply Decoupling

Both V_{DD1} and V_{DD2} must be bypassed with 100 nF ceramic capacitors. These supply the dynamic current required for the isolator switching and should be placed as close as possible to V_{DD} and their respective ground return pins.

Input Configurations

The TxD input should not be left open as the state will be indeterminate. If connected to an open-drain or open collector output, a pull-up resistor (typically 16 k Ω) should be connected from the input to V_{DD1} . This kit has a 16 k Ω pull-up resistor.

The Mode Select (“S”) input has a 150 k Ω nominal internal pull-down resistor. It can be left open or set low for normal operation.

Bus Termination

Because of their relatively low speed, CAN networks can sometimes be unterminated, but reflections are minimized by terminating both ends of the bus (but not every node). Two 120 Ω termination resistors are generally used to match a 60 Ω cable impedance. This kit comes with a 120 Ω termination resistor. The resistor can be removed for multi-node configurations.

Level Shifting

As shown in the figure at right, the IL41050 can provide isolation and level shifting between a 5 volt CAN bus and a 3 volt microcontroller such as an SJA1000 MCU.

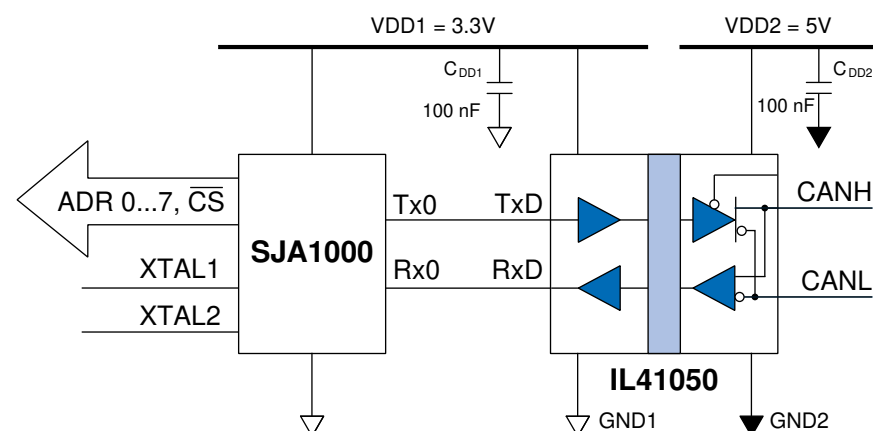

IsoRxD / IsoTxD Outputs

The IsoRxD and IsoTxD outputs are isolated versions of the RxD and TxD signals. These outputs are provided on the IL41050 narrow-body version for troubleshooting, and are brought to test points in this kit. Normally no connections are made to the pins.

Dominant Mode Time-out and Failsafe Receiver Functions

CAN bus latch up is prevented by an integrated Dominant mode timeout function. If the TxD pin is forced permanently low by hardware or software application failure, the time-out returns the RxD output to the high state no more than 765 μ s after TxD is asserted dominant. The timer is triggered by a negative edge on TxD. If the duration of the low is longer than the internal timer value, the transmitter is disabled, driving the bus to the recessive state. The timer is reset by a positive edge on pin TxD.

If V_{DD2} power is lost, the IL41050 asserts the RxD output high when the supply voltage falls below 3.8 V. RxD will return to normal operation when V_{DD2} rises above approximately 4.2 V.

Programmable Power-Up

A unique non-volatile programmable power-up feature prevents unstable nodes. A state that needs to be present at node power up can be programmed at the last power down. For example if a CAN node is required to “pulse” dominant at power up, TxD can be sent low by the controller immediately prior to power down. When power is resumed, the node will immediately go dominant allowing self-check code in the microcontroller to verify node operation. If desired, the node can also power up silently by presetting the TxD line high at power down. At the next power on, the IL41050 will remain silent, awaiting a dominant state from the bus.

The microcontroller can check that the CAN node powered down correctly before applying power at the next “power on” request. If the node powered down as intended, RxD will be set high and stored in the IL41050’s non-volatile memory. The level stored in the RxD bit can be read before isolated node power is enabled, avoiding possible CAN bus disruption due to an unstable node.

Evaluation Board Layout

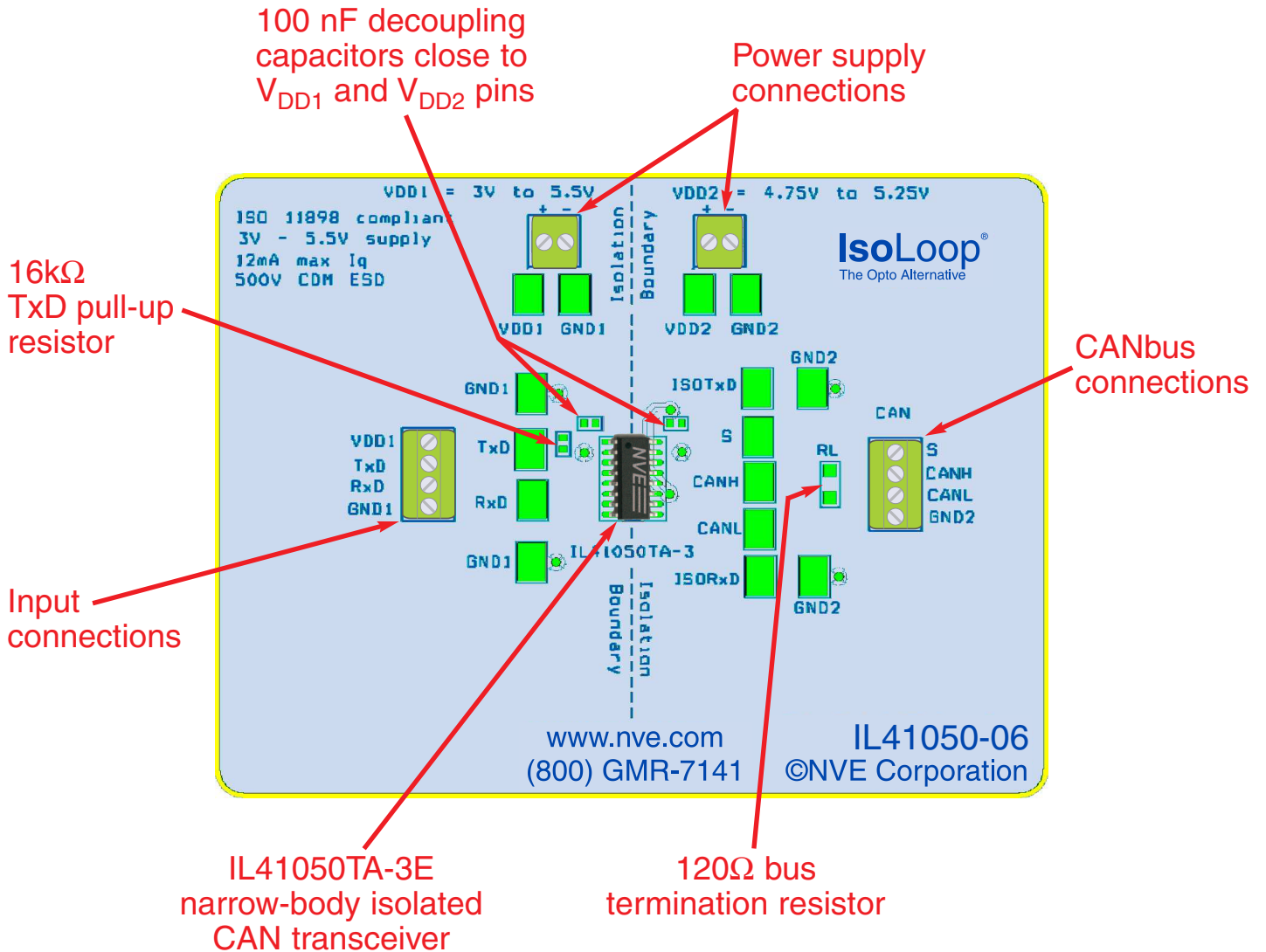

Limited Warranty and Liability

Information in this document is believed to be accurate and reliable. However, NVE does not give any representations or warranties, expressed or implied, as to the accuracy or completeness of such information and shall have no liability for the consequences of use of such information. In no event shall NVE be liable for any indirect, incidental, punitive, special or consequential damages (including, without limitation, lost profits, lost savings, business interruption, costs related to the removal or replacement of any products or rework charges) whether or not such damages are based on tort (including negligence), warranty, breach of contract or any other legal theory.

Right to Make Changes

NVE reserves the right to make changes to information published in this document including, without limitation, specifications and product descriptions at any time and without notice.

Use in Life-Critical or Safety-Critical Applications

Unless NVE and a customer explicitly agree otherwise in writing, NVE products are not designed, authorized or warranted to be suitable for use in life support, life-critical or safety-critical devices or equipment. NVE accepts no liability for inclusion or use of NVE products in such applications and such inclusion or use is at the customer's own risk. Should the customer use NVE products for such application whether authorized by NVE or not, the customer shall indemnify and hold NVE harmless against all claims and damages.

Applications

Applications described in this document are illustrative only. NVE makes no representation or warranty that such applications will be suitable for the specified use without further testing or modification. Customers are responsible for the design and operation of their applications and products using NVE products, and NVE accepts no liability for any assistance with applications or customer product design. It is customer's sole responsibility to determine whether the NVE product is suitable and fit for the customer's applications and products planned, as well as for the planned application and use of customer's third party customers. Customers should provide appropriate design and operating safeguards to minimize the risks associated with their applications and products. NVE does not accept any liability related to any default, damage, costs or problem which is based on any weakness or default in the customer's applications or products, or the application or use by customer's third party customers. The customer is responsible for all necessary testing for the customer's applications and products using NVE products in order to avoid a default of the applications and the products or of the application or use by customer's third party customers. NVE accepts no liability in this respect.

An ISO 9001 Certified Company

NVE Corporation
11409 Valley View Road
Eden Prairie, MN 55344-3617

©NVE Corporation

All rights are reserved. Reproduction in whole or in part is prohibited without the prior written consent of the copyright owner.

Manual No.: ISB-CB-007

August 2012