



Chipsmall Limited consists of a professional team with an average of over 10 year of expertise in the distribution of electronic components. Based in Hongkong, we have already established firm and mutual-benefit business relationships with customers from,Europe,America and south Asia,supplying obsolete and hard-to-find components to meet their specific needs.

With the principle of “Quality Parts,Customers Priority,Honest Operation,and Considerate Service”,our business mainly focus on the distribution of electronic components. Line cards we deal with include Microchip,ALPS,ROHM,Xilinx,Pulse,ON,Everlight and Freescale. Main products comprise IC,Modules,Potentiometer,IC Socket,Relay,Connector.Our parts cover such applications as commercial,industrial, and automotives areas.

We are looking forward to setting up business relationship with you and hope to provide you with the best service and solution. Let us make a better world for our industry!



## Contact us

Tel: +86-755-8981 8866 Fax: +86-755-8427 6832

Email & Skype: info@chipsmall.com Web: www.chipsmall.com

Address: A1208, Overseas Decoration Building, #122 Zhenhua RD., Futian, Shenzhen, China



# IsoLoop<sup>®</sup> IL700-Series Isolator Evaluation Board

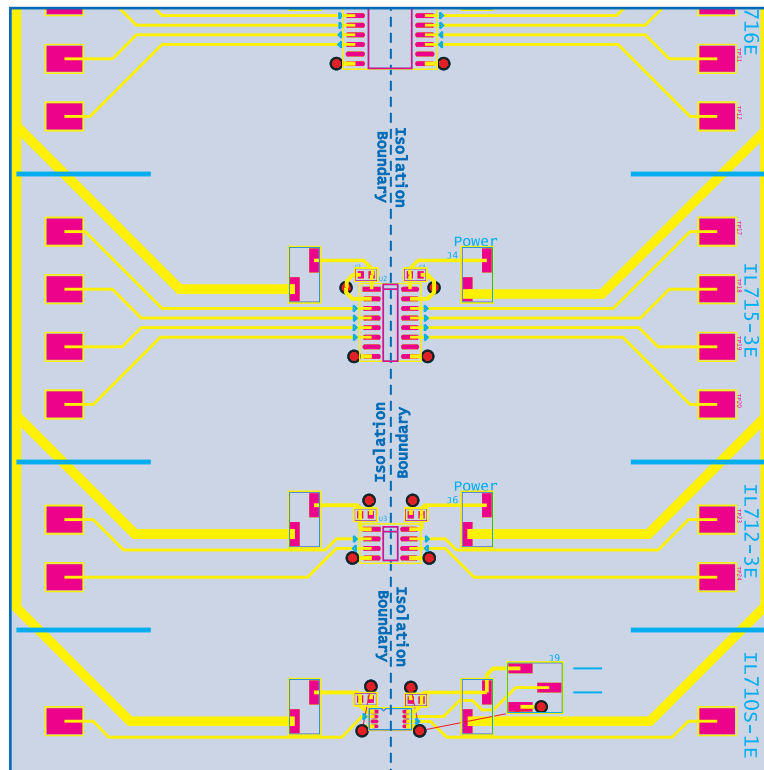

Board No.: IL700-01

# About This Board

This evaluation board lets you try a variety of NVE's flagship series of award-winning of IsoLoop Isolators.

The board has four IL700-Series isolators in four package types:

- IL716E (wide-body SOIC-16)
- IL715-3E (narrow-body SOIC-16)
- IL712-3E (SOIC-8)
- IL710S-1E (MSOP-8)

IL700-Series Isolators use patented spintronic Giant Magnetoresistive (GMR) technology. The symmetric magnetic coupling barrier provides a typical propagation delay of only 10 ns and a pulse width distortion as low as 300 ps, the best of any isolator. And their real ceramic/polymer barriers last pretty much forever.

## **IL700 /IL200-Series Specification Highlights**

- Up to 150 Mbps (S-Series)
- PWD to 300 ps (S-Series)
- 100 ps Typical Pulse Jitter
- 10 ns Typical Propagation Delay
- 4 ns Typical Prop. Delay Skew
- 2 mA/Channel Max. Quiescent Current
- Up to 125°C (T-Series)
- 2.5 kVrms Isolation (1 min.)
- 25,000 Year Barrier Life
- UL1577 and IEC61010 Approved
- MSOP, SOIC, and PDIP Packages

# Application Information

## Why Isolate?

Isolation reduces noise, eliminates ground loops, and improves safety.

## Applications

Popular IL700/IL200 applications include multiplexed data transmission, board-to-board communication, serial communications, and logic-level shifting.

## Board Layout Speed Limitations

Circuit board traces should be as short as possible with a minimum of vias for best performance. Since the evaluation board was designed for ease of use and with test points, it may not provide maximum speed.

## Electrostatic Discharge Sensitivity

This product has been tested for electrostatic sensitivity to the limits in the datasheet. However, all integrated circuits and boards should be handled with appropriate care to avoid damage. Damage caused by inappropriate handling or storage could range from performance degradation to complete failure.

## Electromagnetic Compatibility

IsoLoop Isolators have the lowest EMC footprint of any isolation technology. IsoLoop Isolators' Wheatstone bridge configuration and differential magnetic field signaling ensure excellent EMC performance against all relevant standards. These isolators are fully compliant with generic EMC standards EN50081, EN50082-1 and the umbrella line-voltage standard for Information Technology Equipment (ITE) EN61000.

## Power Supply Decoupling and Ground Planes

As shown on this board, both isolator power supplies should be decoupled with low-ESR 47 nF ceramic capacitors. Bypass capacitors should be as close as possible to the  $V_{DD}$  pins. Ground planes for both  $GND_1$  and  $GND_2$  are recommended for data rates above 10 Mbps.

## Signal Status on Start-up and Shut Down

To minimize power dissipation, IL700 input signals are differentiated and then latched on the output side of the isolation barrier to reconstruct the signal. This could result in an ambiguous output state depending on power up, shutdown and power loss sequencing. Therefore, the designer should consider including an initialization signal in the start-up circuit. Initialization consists of toggling the input either high then low, or low then high.

# Serial Interface Illustrative Applications

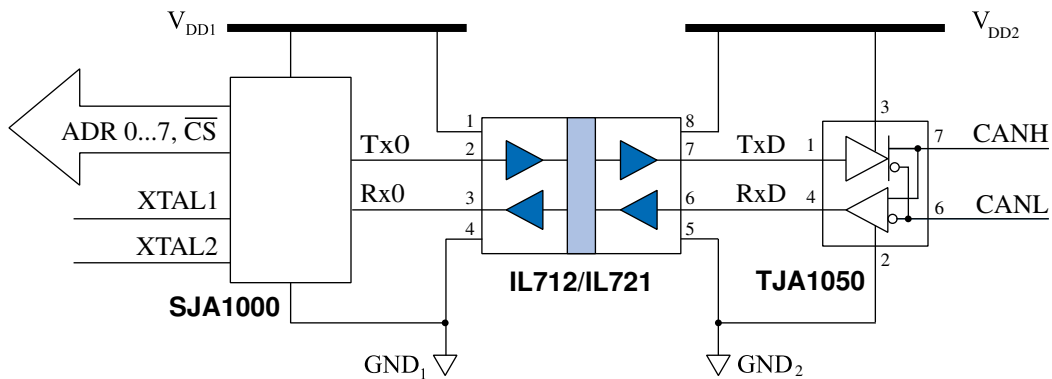

## Isolating Standard CAN Transceivers

Isolating CANbus allows higher speed and more reliable operation by eliminating ground loops and reducing noise susceptibility. This simple circuit works with any CAN transceiver with a TxD dominant timeout, which includes all of the current-generation transceivers including the ubiquitous Philips/NXP TJA1050. Propagation delay is critical for CANbus, and the IL712 and IL721 bidirectional isolators have best-in-class propagation delay of 10 ns.

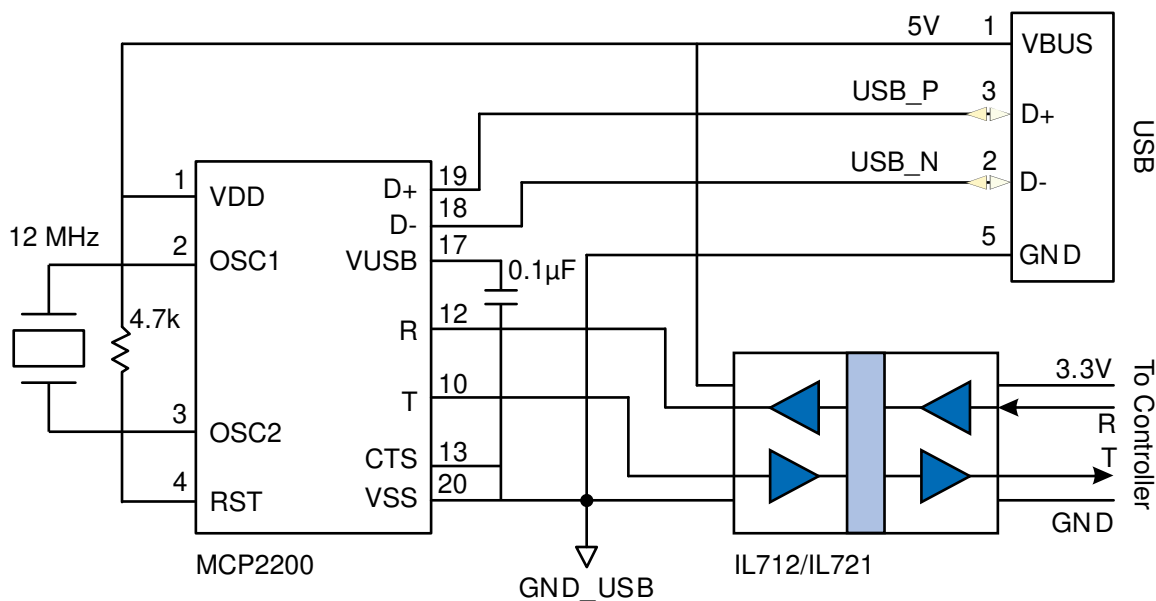

## Isolated USB UART Using an IL712 or IL721

Isolating the input to a USB controller (rather than the bus lines) requires fewer isolation channels and is therefore usually the simplest solution, as shown above. The Microchip MCP2200 is a USB 2.0 to UART protocol converter.

Visit [www.IsoLoop.com](http://www.IsoLoop.com) for more illustrative IsoLoop Isolator applications.

# ADC and DAC Illustrative Applications

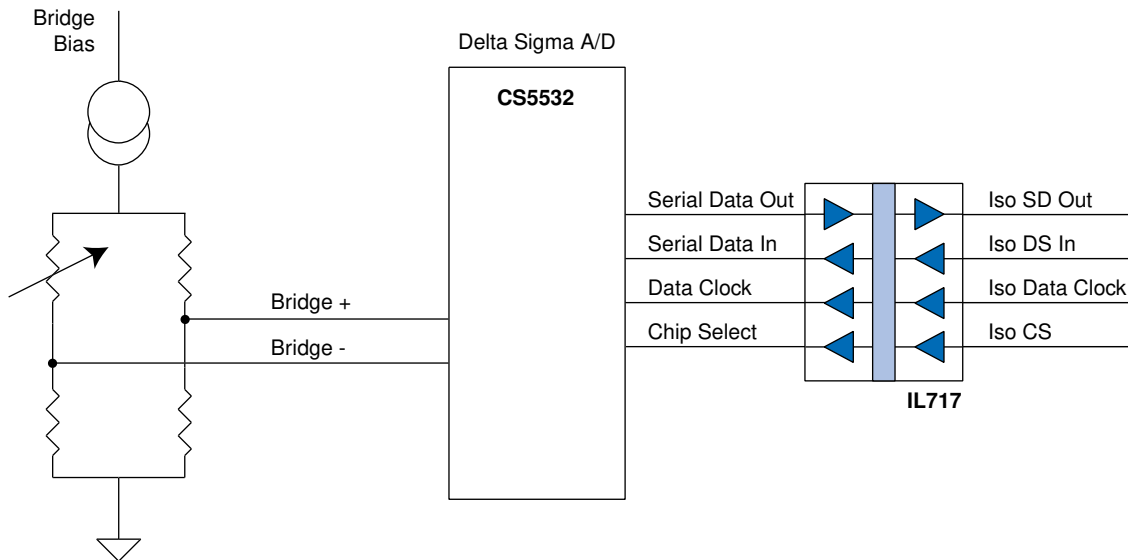

## Single-Channel Isolated SPI Delta-Sigma A/D Converter Using IL717

This circuit illustrates a typical single-channel delta-sigma isolated ADC SPI interface. The A/D is located on the bridge with no signal conditioning electronics between the bridge sensor and the ADC. In this case, the IL717 is the best choice for isolation. It isolates the control bus from the microcontroller. The system clock is located on the isolated side of the system.

## Multi-Channel Isolated Sampling A/D Converter

The IL261 is ideal for isolating multi-channel sampling ADCs. Isolated channels A0 and A1 control the analog channel being sampled, while the three remaining IL261 I/O lines isolate the SPI interface.

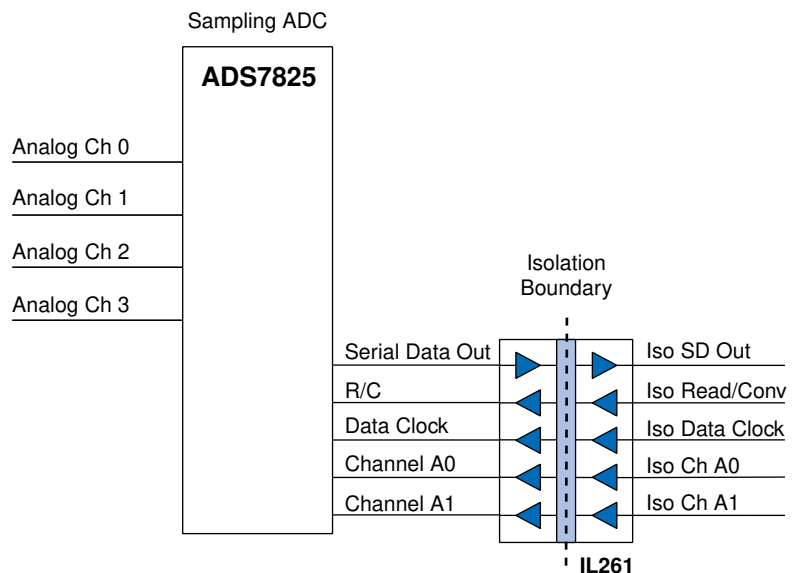

Visit [www.IsoLoop.com](http://www.IsoLoop.com) for more illustrative IsoLoop Isolator applications.

# Other Illustrative Applications

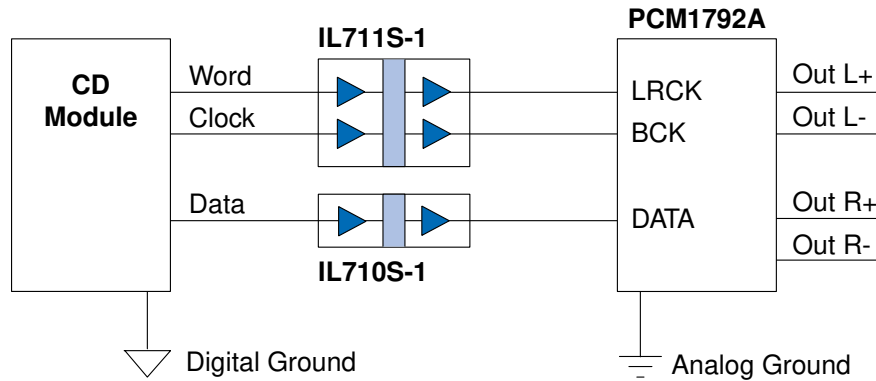

## Isolated I<sup>2</sup>S Using IL710/IL711

Isolating a CD transport DAC with an isolated Inter-IC Sound (I<sup>2</sup>S) bus eliminates ground loops. The IL700-Series isolators' precision edge placement (just 100 ps jitter) all but eliminates noise-induced phase error and hum in the analog side of the audio system.

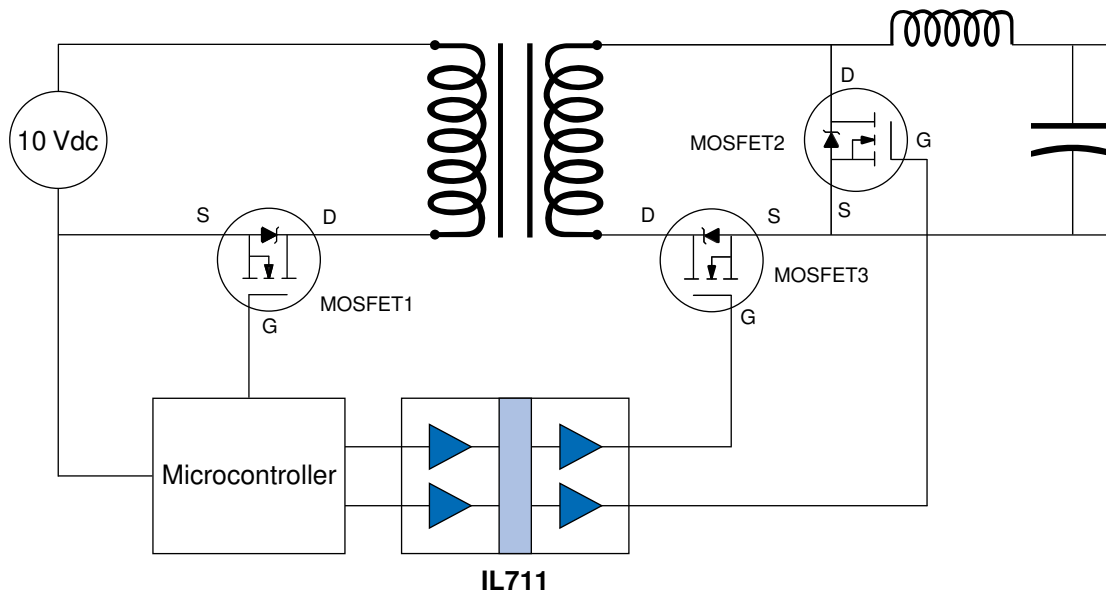

## Intelligent DC-DC Converter With Synchronous Rectification

A typical primary-side controller uses an IL711 to drive the synchronous rectification signals from primary side to secondary side. Isolator pulse-width distortion as low as 0.3 ns minimizes MOSFET dead time and maximizes conversion efficiency.

Visit [www.IsoLoop.com](http://www.IsoLoop.com) for more illustrative IsoLoop Isolator applications.

# IL700/IL200 Series High-Performance Isolators

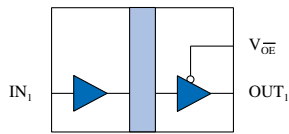

IL710

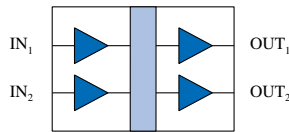

IL711

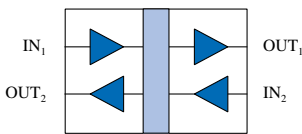

IL712

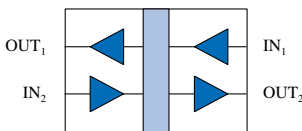

IL721

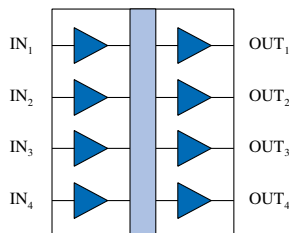

IL715

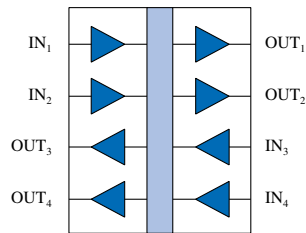

IL716

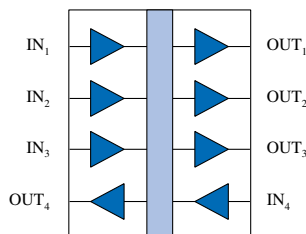

IL717

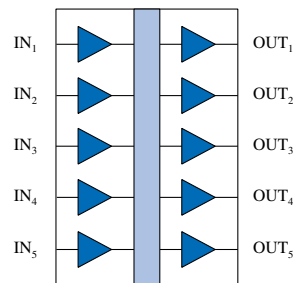

IL260

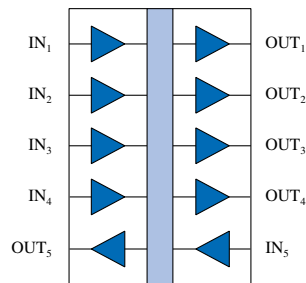

IL261

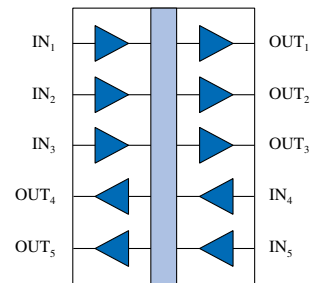

IL262

## Features:

- **IL200 Series**  
Five channels per package
- **IL700-1 Series**  
World's smallest isolators (MSOP-8)
- **IL700S Series**  
Fastest (150 Mbps)  
and lowest PWD (300 ps)
- **IL700T Series**  
Highest operating temperature  
(125°C with no derating)

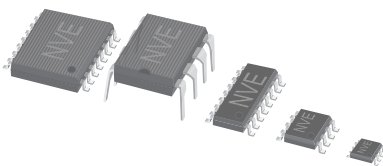

Parameters	Min.	Typ.	Max.	Units
Data Rate (S-Series)	100 (130)	110 (150)		Mbps
PWD (S-Series)		3 (0.3)	3	ns
Propagation Delay		10	15	ns
Propagation Delay Skew		4	6	ns
Pulse Jitter		100		ps
Quiescent Current		1.5	2	mA/ch
Transient Immunity	20	30		kV/μs
Temperature Range (T-Series)	-40		+100 (+125)	°C
IL200 Series	-40		+85	°C



### **Limited Warranty and Liability**

Information in this document is believed to be accurate and reliable. However, NVE does not give any representations or warranties, expressed or implied, as to the accuracy or completeness of such information and shall have no liability for the consequences of use of such information. In no event shall NVE be liable for any indirect, incidental, punitive, special or consequential damages (including, without limitation, lost profits, lost savings, business interruption, costs related to the removal or replacement of any products or rework charges) whether or not such damages are based on tort (including negligence), warranty, breach of contract or any other legal theory.

### **Right to Make Changes**

NVE reserves the right to make changes to information published in this document including, without limitation, specifications and product descriptions at any time and without notice.

### **Use in Life-Critical or Safety-Critical Applications**

Unless NVE and a customer explicitly agree otherwise in writing, NVE products are not designed, authorized or warranted to be suitable for use in life support, life-critical or safety-critical devices or equipment. NVE accepts no liability for inclusion or use of NVE products in such applications and such inclusion or use is at the customer's own risk. Should the customer use NVE products for such application whether authorized by NVE or not, the customer shall indemnify and hold NVE harmless against all claims and damages.

### **Applications**

Applications described in this document are illustrative only. NVE makes no representation or warranty that such applications will be suitable for the specified use without further testing or modification. Customers are responsible for the design and operation of their applications and products using NVE products, and NVE accepts no liability for any assistance with applications or customer product design. It is customer's sole responsibility to determine whether the NVE product is suitable and fit for the customer's applications and products planned, as well as for the planned application and use of customer's third party customers. Customers should provide appropriate design and operating safeguards to minimize the risks associated with their applications and products. NVE does not accept any liability related to any default, damage, costs or problem which is based on any weakness or default in the customer's applications or products, or the application or use by customer's third party customers. The customer is responsible for all necessary testing for the customer's applications and products using NVE products in order to avoid a default of the applications and the products or of the application or use by customer's third party customers. NVE accepts no liability in this respect.

## **An ISO 9001 Certified Company**

NVE Corporation  
11409 Valley View Road  
Eden Prairie, MN 55344-3617

©NVE Corporation

All rights are reserved. Reproduction in whole or in part is prohibited without the prior written consent of the copyright owner.

Manual No.: ISB-CB-005

February 2012