



Chipsmall Limited consists of a professional team with an average of over 10 year of expertise in the distribution of electronic components. Based in Hongkong, we have already established firm and mutual-benefit business relationships with customers from,Europe,America and south Asia,supplying obsolete and hard-to-find components to meet their specific needs.

With the principle of “Quality Parts,Customers Priority,Honest Operation,and Considerate Service”,our business mainly focus on the distribution of electronic components. Line cards we deal with include Microchip,ALPS,ROHM,Xilinx,Pulse,ON,Everlight and Freescale. Main products comprise IC,Modules,Potentiometer,IC Socket,Relay,Connector.Our parts cover such applications as commercial,industrial, and automotives areas.

We are looking forward to setting up business relationship with you and hope to provide you with the best service and solution. Let us make a better world for our industry!



Contact us

Tel: +86-755-8981 8866 Fax: +86-755-8427 6832

Email & Skype: info@chipsmall.com Web: www.chipsmall.com

Address: A1208, Overseas Decoration Building, #122 Zhenhua RD., Futian, Shenzhen, China



Inolux Surface Mount High Power Ultraviolet LED IN-3531ACUV

Official Product	Product: IN-3531ACUV			Data Sheet No.
Tentative Product	*****			IN-3531ACUV
Specifications are subject to change without notice. Data and drawings herein are copyrighted.		Aug. 21, 2015	Version of 1.1	Page 1/13

DISCLAIMER	3
LABEL SPECIFICATIONS	4
RADIOMETRIC POWER AND FORWARD VOLTAGE	5
FORWARD VOLTAGE BINNING	6
PRODUCT CHARACTERISTICS	6
ABSOLUTE MAXIMUM RATINGS	6
ELECTRO-OPTICAL CHARACTERISTICS	7
PACKAGE OUTLINE DIMENSION	8
RECOMMENDED SOLDERING PATTERN FOR REFLOW SOLDERING	8
CHARACTERISTIC CURVES	9
THERMAL DESIGN	10
PACKING INFORMATION	12
REVISION HISTORY	13

Official Product	Product: IN-3531ACUV		Data Sheet No.
Tentative Product	*****		IN-3531ACUV
Specifications are subject to change without notice. Data and drawings herein are copyrighted.	Aug. 21, 2015	Version of 1.1	Page 2/13

DISCLAIMER

INOLUX reserves the right to make changes without further notice to any products herein to improve reliability, function or design. INOLUX does not assume any liability arising out of the application or use of any product or circuit described herein; neither does it convey any license under its patent rights, nor the rights of others.

LIFE SUPPORT POLICY

INOLUX's products are not authorized for use as critical components in life support devices or systems without the express written approval of the President of INOLUX or INOLUX CORPORATION. As used herein:

1. Life support devices or systems are devices or systems which, (a) are intended for surgical implant into the body, or (b) support or sustain life, and (c) whose failure to perform when properly used in accordance with instructions for use provided in the labeling, can be reasonably expected to result in a significant injury of the user.
2. A critical component in any component of a life support device or system whose failure to perform can be reasonably expected to cause the failure of the life support device or system, or to affect its safety or effectiveness.

Official Product	Product: IN-3531ACUV	Data Sheet No.	
Tentative Product	*****	IN-3531ACUV	
Specifications are subject to change without notice. Data and drawings herein are copyrighted.	Aug. 21, 2015	Version of 1.1	Page 3/13

Label Specifications
INOLUX P/N:
I N - 3 5 3 1 A C U V - X X X X

↓	↓	↓
Series Name	Substrate / Emitting Color	Customer Code
IN-3531 Inolux 3531 package	Aluminum Nitride substrate UV@380-420nm	XXXX Customer Product Code

Lot No.:

1	2	3	4	5	6	7	8	9	10
E	1	A	1	A	2	2	L	1	2
Code 1 2		Code 3	Code 4	Code 5	Code 6	Code 7	Code 8	Code 9	Code 10
		Mfg. Year	Mfg. Month	Mfg. Date	Consecutive number		Special code		
Internal Tracing Code		2010-A 2011-B 2012-C 2013-D . .	1:Jan. 2:Feb. A:Oct. B:Nov. C:Dec.	1:A 2:B 3:C ... 26:Z 27:7 28:8 29:9 30:3 31:4	01~ZZ		000~ZZZ		

Official Product	Product: IN-3531ACUV	Data Sheet No.
Tentative Product	*****	IN-3531ACUV
Specifications are subject to change without notice. Data and drawings herein are copyrighted.	Aug. 21, 2015	Version of 1.1
		Page 4/13

Radiometric Power and Forward Voltage

 (T_j =25 °C)

Part Number	Color	Performance at Test Current 500mA				Performance at 1000mA
		Group	Min. Radiometric Power (mW)	V _f		Typical Radiometric Power (mW)
				Min	Max	
IN-3531ACUV	U40 (380~390nm)	NE1	400	3.2	4.2	750
		NE2	440	3.2	4.2	820
		NE3	480	3.2	4.2	890
		NE4	520	3.2	4.2	960
		NE5	560	3.2	4.2	1030
	U50 (390~400nm)	NE4	520	3.2	4.2	960
		NE5	560	3.2	4.2	1030
		NF1	600	3.2	4.2	1100
		NF2	650	3.2	4.2	1200
		NF3	700	3.2	4.2	1300
		NF4	750	3.2	4.2	1400
	U60 (400~410nm)	NE4	520	3.2	4.2	960
		NE5	560	3.2	4.2	1030
		NF1	600	3.2	4.2	1100
		NF2	650	3.2	4.2	1200
		NF3	700	3.2	4.2	1300
		NF4	750	3.2	4.2	1400
	U70 (410~420nm)	NE4	520	3.2	4.2	960
		NE5	560	3.2	4.2	1030
		NF1	600	3.2	4.2	1100
		NF2	650	3.2	4.2	1200
		NF3	700	3.2	4.2	1300
		NF4	750	3.2	4.2	1400

Note:

1. Radiometric Power is measured with an accuracy of ±10%
 2. The forward voltage is measured with an accuracy of ±0.2V
- * Calculated values are for reference only.

Official Product	Product: IN-3531ACUV	Data Sheet No.
Tentative Product	*****	IN-3531ACUV
Specifications are subject to change without notice. Data and drawings herein are copyrighted.	Aug. 21, 2015	Version of 1.1
		Page 5/13

Forward Voltage Binning

Part Number	Performance at Test Current (500mA)		
	V _f Group	Minimum (V)	Maximum (V)
IN-3531ACUV	V30	3.0	3.2
	V32	3.2	3.4
	V34	3.4	3.6
	V36	3.6	3.8
	V38	3.8	4.0
	V40	4.0	4.2

Product Characteristics
Absolute Maximum Ratings

(T_j =25 °C)

Parameter	Rating
DC Forward Current (mA)	1000mA
LED Junction Temperature	150°C
LED Operating Temperature	-40°C ~ 125°C
Storage Temperature	-40°C ~ 125°C
Soldering Temperature	Max. 260°C / Max. 10 sec. (JEDEC 020c)
ESD Sensitivity	2,000V HBM (JESD-22A-114-B)
Preconditioning	Acc. to JEDEC Level 2

Notes:

1. Never operate the LEDs in reverse bias.
2. Do not drive at rated current for more than 5 seconds without proper thermal management.
3. When the LEDs are illuminating, operating current should be decided after considering the packages maximum temperature.
4. Caution: These devices emit high intensity UV/NUV light. Necessary precautions must be taken during operation. Do not look directly into the light or look through the optical system when in operation. Protective eyewear should be worn at all times during operation.
5. Lens discoloration may occur with prolonged exposure to UV/NUV light. Lens material will need to be tested for UV/NUV light compatibility and durability.

Official Product	Product: IN-3531ACUV	Data Sheet No.
Tentative Product	*****	IN-3531ACUV
Specifications are subject to change without notice. Data and drawings herein are copyrighted.	Aug. 21, 2015	Version of 1.1
		Page 6/13

Electro-Optical Characteristics

 (T_j 25 °C)

Part Number	Color	Peak Wavelength (λ _p)		2θ _{1/2}	Temperature Coefficient of Vf (mV/°C)	Thermal Resistance Junction to Pad
		Min	Max		ΔV _F /ΔT _J	(°C/W) Rθ _{J-L}
IN-3531ACUV	U40	380	390	125	-2~-4	4.4
	U50	390	400	125	-2~-4	4.4
	U60	400	410	125	-2~-4	4.4
	U70	410	420	125	-2~-4	4.4

Notes:

1. The peak/dominant wavelength is measured with an accuracy of ±1nm.

Official Product	Product: IN-3531ACUV		Data Sheet No.
Tentative Product	*****		IN-3531ACUV
Specifications are subject to change without notice. Data and drawings herein are copyrighted.		Aug. 21, 2015	Version of 1.1
			Page 7/13

Package Outline Dimension
Recommended Soldering Pattern for Reflow Soldering

Unit: mm Tolerance: +/-0.13

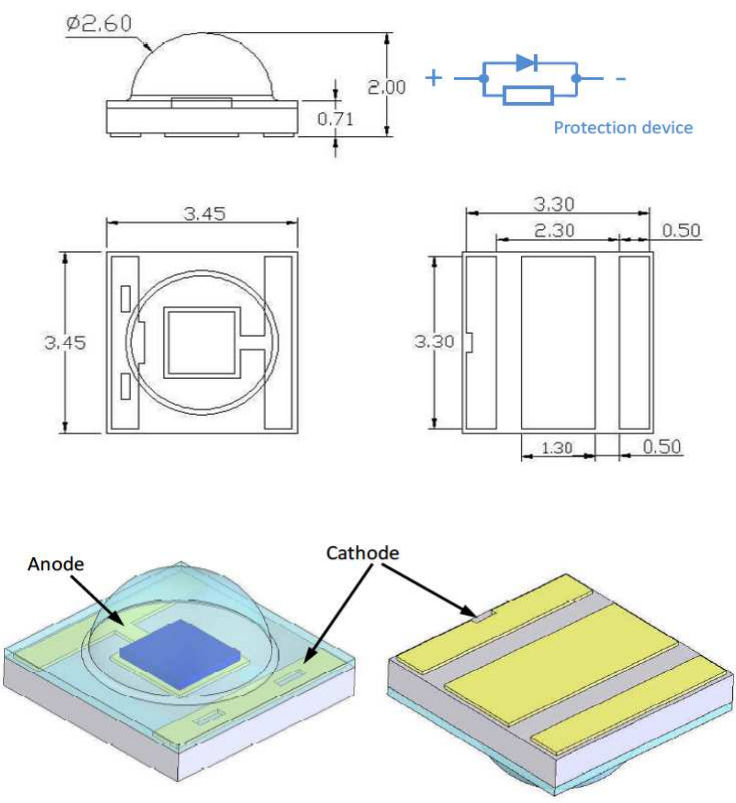
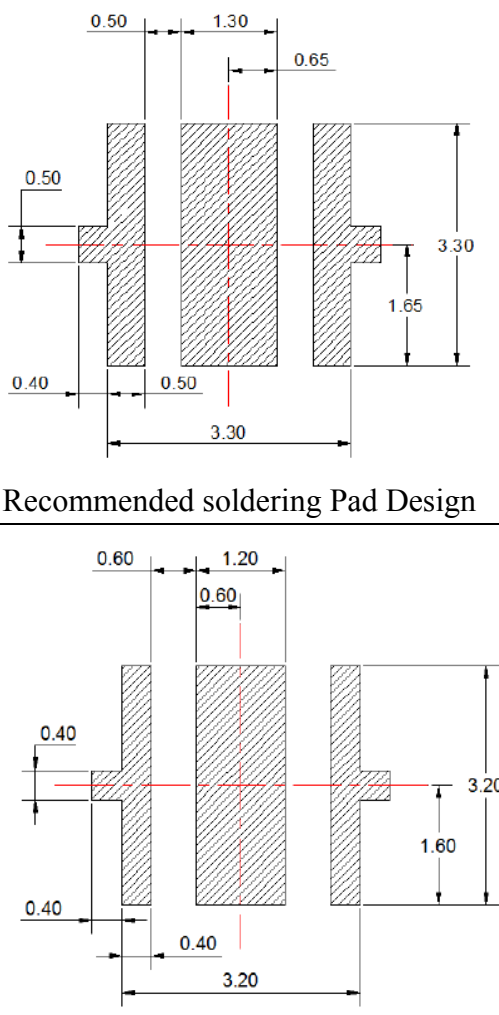
Outline Dimension	Solder Pattern
 <p> $\phi 2.60$ 2.00 0.71 3.45 3.45 3.30 2.30 0.50 1.30 0.50 Anode Cathode </p>	 <p> 0.50 1.30 0.65 0.50 3.30 1.65 0.40 0.50 3.30 Recommended soldering Pad Design 0.60 1.20 0.60 0.40 3.20 1.60 0.40 0.40 3.20 Recommend Stencil Pattern Design (Marked Area is Opening) </p>
<p>Soldering terminals may shift in the x, y direction.</p>	<p>Unit: mm</p>

Official Product	Product: IN-3531ACUV	Data Sheet No.
Tentative Product	*****	IN-3531ACUV
Specifications are subject to change without notice. Data and drawings herein are copyrighted.	Aug. 21, 2015	Version of 1.1 Page 8/13

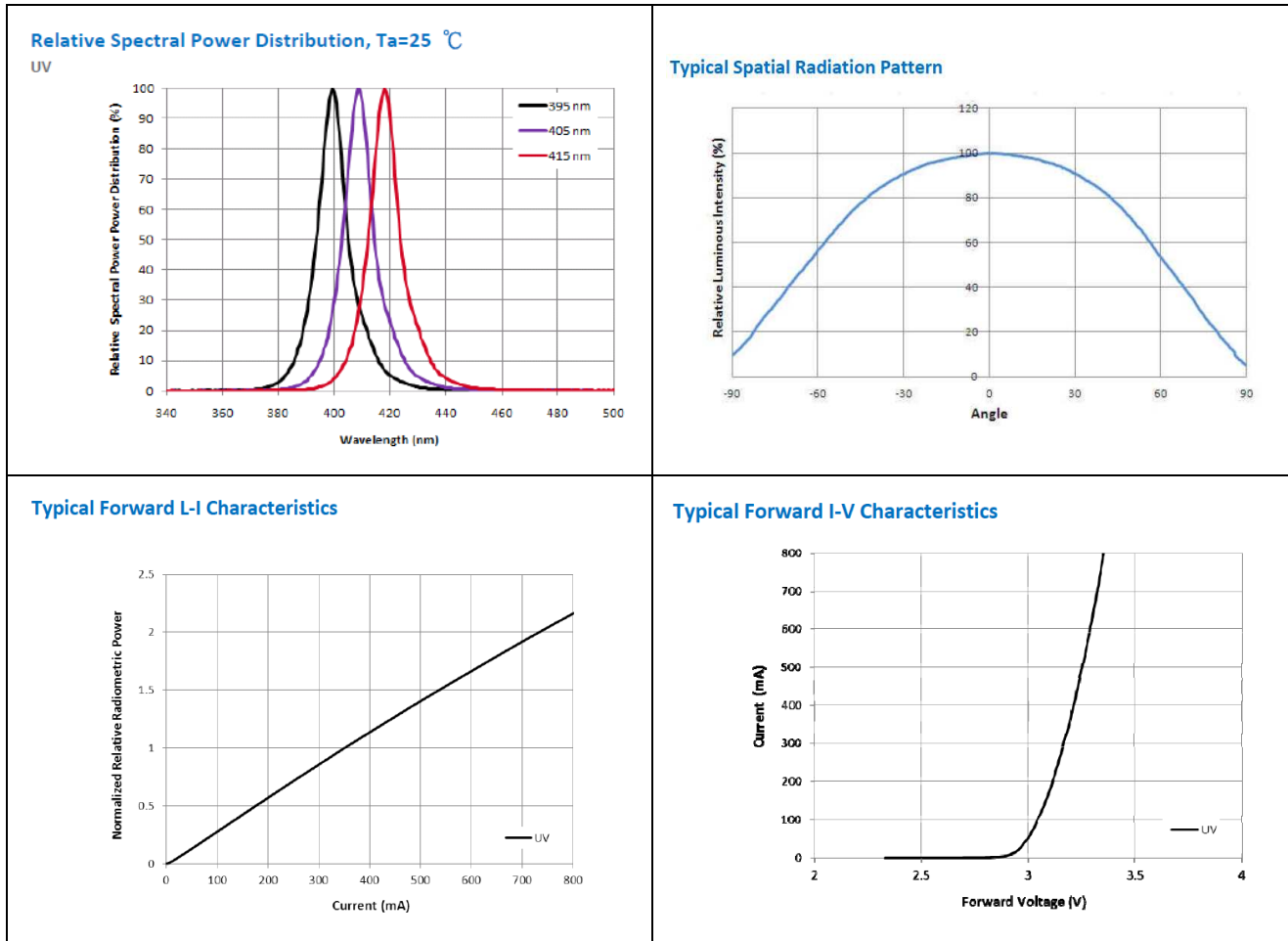
Characteristic Curves

Official Product	Product: IN-3531ACUV	Data Sheet No.
Tentative Product	*****	IN-3531ACUV
Specifications are subject to change without notice. Data and drawings herein are copyrighted.	Aug. 21, 2015	Version of 1.1
		Page 9/13

Thermal Design

Thermal design of the end product is important. The thermal resistance between the junction and the solder point ($R_{\theta J-S}$) and the end product should be designed to minimize the thermal resistance from the solder point to ambient in order to optimize the emitter life and optical characteristics. The maximum operation current is determined by the plot of Allowable Forward Current vs. Ambient Temperature.

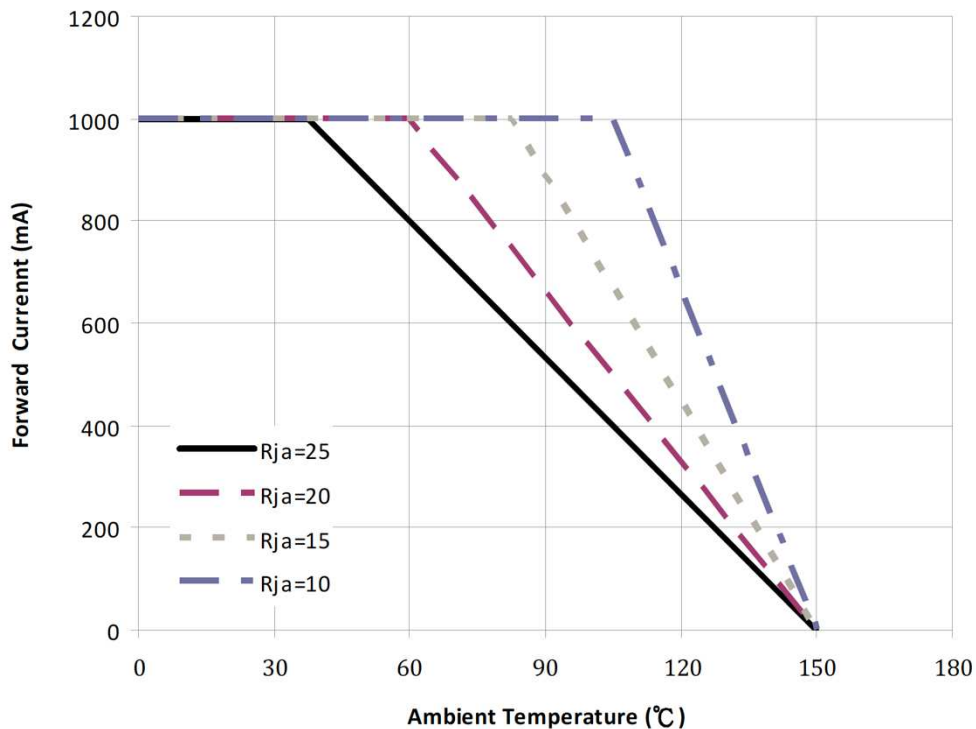

The junction temperature can be correlated to the thermal resistance between the junction and ambient (R_{ja}) by the following equation.

$$T_j = T_a + R_{ja} * W$$

T_j : LED junction temperature

T_a : Ambient temperature

R_{ja} : Thermal resistance between the junction and ambient

W : Input power ($I_F * V_F$)

Official Product	Product: IN-3531ACUV	Data Sheet No.
Tentative Product	*****	IN-3531ACUV
Specifications are subject to change without notice. Data and drawings herein are copyrighted.	Aug. 21, 2015	Version of 1.1
		Page 10/13

Reflow Soldering

The LEDs can be soldered using the parameter listed below. As a general guideline, the users are suggested to follow the recommended soldering profile provided by the manufacturer of the solder paste. Although the recommended soldering conditions are specified in the list, reflow soldering at the lowest possible temperature is preferred for the LEDs.

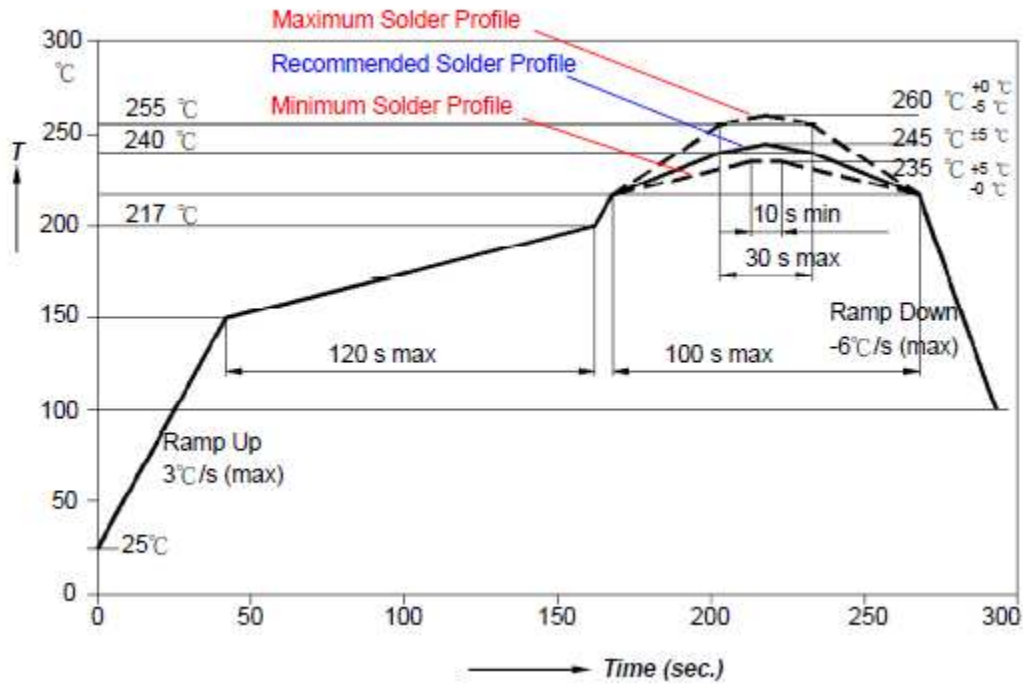

Profile Feature	Sn-Pb Eutectic Assembly	Pb-Free Assembly
Average Ramp-up Rate (T _{smax} to T _p)	3°C/second max.	3°C/second max.
Preheat		
- Temperature Min(T _{smin})	100°C	150°C
- Temperature Max(T _{smax})	150°C	200°C
- Time(t _{smin} to t _{smax})	60-120 seconds	60-180 seconds
Time maintained above:		
- Temperature(T _L)	183°C	217°C
- Time(t _L)	60-150 seconds	60-150 seconds
Peak/classification Temperature(T _p)	215°C	260°C
Time within 5°C of actual Peak Temperature(t _p)	10-30 seconds	20-40 seconds
Ramp-Down Rate	6°C/second max.	6°C/second max.
Time 25°C to Peak Temperature	6 minutes max.	8 minutes max.

Official Product	Product: IN-3531ACUV	Data Sheet No.
Tentative Product	*****	IN-3531ACUV
Specifications are subject to change without notice. Data and drawings herein are copyrighted.	Aug. 21, 2015	Version of 1.1
		Page 11/13

Packing Information

The carrier tape is conformal to EIA-481D

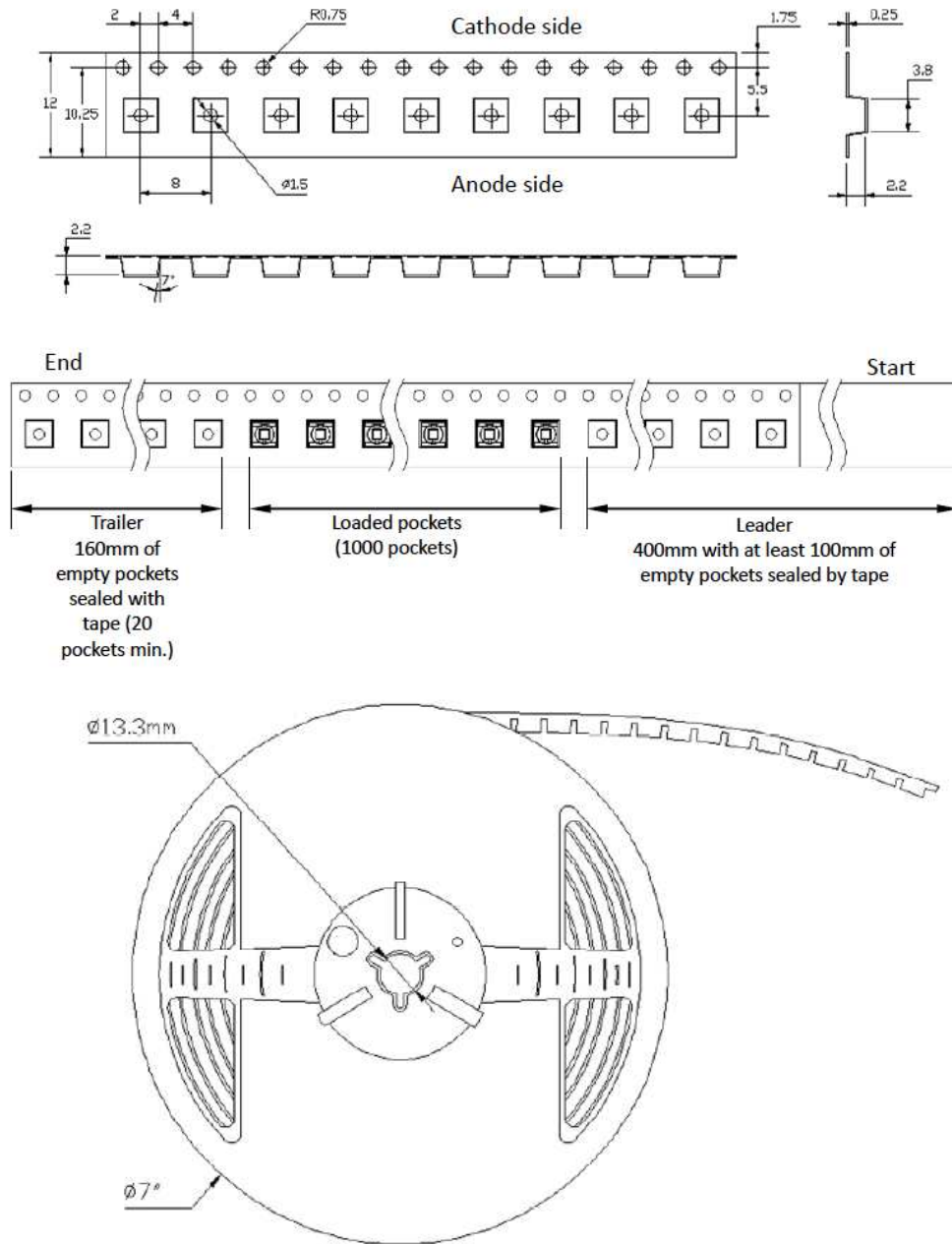

Note : All Dimensions are in millimeter

Official Product	Product: IN-3531ACUV	Data Sheet No.	
Tentative Product	*****	IN-3531ACUV	
Specifications are subject to change without notice. Data and drawings herein are copyrighted.	Aug. 21, 2015	Version of 1.1	Page 12/13

Revision History

Changes since last revision	Page	Version No.	Revision Date
Initial release		1.0	01-17-2013
Format update		1.1	08-21-2015

Official Product	Product: IN-3531ACUV		Data Sheet No.
Tentative Product	*****		IN-3531ACUV
Specifications are subject to change without notice. Data and drawings herein are copyrighted.	Aug. 21, 2015	Version of 1.1	Page 13/13