



Chipsmall Limited consists of a professional team with an average of over 10 year of expertise in the distribution of electronic components. Based in Hongkong, we have already established firm and mutual-benefit business relationships with customers from,Europe,America and south Asia,supplying obsolete and hard-to-find components to meet their specific needs.

With the principle of “Quality Parts,Customers Priority,Honest Operation,and Considerate Service”,our business mainly focus on the distribution of electronic components. Line cards we deal with include Microchip,ALPS,ROHM,Xilinx,Pulse,ON,Everlight and Freescale. Main products comprise IC,Modules,Potentiometer,IC Socket,Relay,Connector.Our parts cover such applications as commercial,industrial, and automotives areas.

We are looking forward to setting up business relationship with you and hope to provide you with the best service and solution. Let us make a better world for our industry!



## Contact us

Tel: +86-755-8981 8866 Fax: +86-755-8427 6832

Email & Skype: info@chipsmall.com Web: www.chipsmall.com

Address: A1208, Overseas Decoration Building, #122 Zhenhua RD., Futian, Shenzhen, China



## Important notice

Dear Customer,

On 7 February 2017 the former NXP Standard Product business became a new company with the tradename **Nexperia**. Nexperia is an industry leading supplier of Discrete, Logic and PowerMOS semiconductors with its focus on the automotive, industrial, computing, consumer and wearable application markets

In data sheets and application notes which still contain NXP or Philips Semiconductors references, use the references to Nexperia, as shown below.

Instead of <http://www.nxp.com>, <http://www.philips.com/> or <http://www.semiconductors.philips.com/>, use <http://www.nexperia.com>

Instead of [sales.addresses@www.nxp.com](mailto:sales.addresses@www.nxp.com) or [sales.addresses@www.semiconductors.philips.com](mailto:sales.addresses@www.semiconductors.philips.com), use [salesaddresses@nexperia.com](mailto:salesaddresses@nexperia.com) (email)

Replace the copyright notice at the bottom of each page or elsewhere in the document, depending on the version, as shown below:

- © NXP N.V. (year). All rights reserved or © Koninklijke Philips Electronics N.V. (year). All rights reserved

Should be replaced with:

- © **Nexperia B.V. (year). All rights reserved.**

If you have any questions related to the data sheet, please contact our nearest sales office via e-mail or telephone (details via [salesaddresses@nexperia.com](mailto:salesaddresses@nexperia.com)). Thank you for your cooperation and understanding,

Kind regards,

Team Nexperia

# IP4302CX2/A

Low profile bidirectional low capacitance ESD protection diode

Rev. 1 — 28 November 2011

Product data sheet

## 1. Product profile

---

### 1.1 General description

The IP4302CX2/A is a bidirectional diode which is designed to provide protection to downstream components from ElectroStatic Discharge (ESD) voltages as high as  $\pm 15$  kV contact discharge according to the IEC 61000-4-2 model, far exceeding standard level 4.

The device is fabricated using monolithic silicon technology and integrates one pair of back-to-back diodes in a 0.4 mm pitch Wafer-Level Chip-Scale Package (WLCSP). These features make the IP4302CX2/A ideal for use in applications requiring the utmost in miniaturization such as mobile phone handsets, cordless telephones and other portable electronic devices.

### 1.2 Features and benefits

- Pb-free, RoHS compliant and free of halogen and antimony (Dark Green compliant)
- Bidirectional ESD protection of one line
- Integrated ESD protection withstanding  $\pm 15$  kV contact discharge, far exceeding IEC 61000-4-2 level 4
- Ultra low height of 0.40 mm only
- 0.52 mm  $\times$  0.7 mm size package

### 1.3 Applications

- Cellular handsets and accessories
- Portable electronics
- Subscriber Identity Module (SIM) card protection
- Communication systems
- Computers and peripherals



### 1.4 Quick reference data

**Table 1. Quick reference data**  
*T<sub>amb</sub> = 25 °C; unless otherwise specified.*

Symbol	Parameter	Conditions	Min	Typ	Max	Unit
V <sub>BR</sub>	breakdown voltage	I <sub>R</sub> = 1 mA	14.0	16.5	-	V
		I <sub>R</sub> = -1 mA	-	-16.5	-14.0	V
C <sub>d</sub>	diode capacitance	f = 1 MHz; V <sub>R</sub> = 0 V	-	-	10	pF
V <sub>ESD</sub>	electrostatic discharge voltage	contact discharge	[1][2] -15	-	+15	kV

- [1] Device is qualified with 1000 pulses of ±15 kV contact discharges each, according to the IEC 61000-4-2 model and far exceeds the specified level 4 (8 kV contact discharge).
- [2] A special robust test is performed stressing the devices with ≥ 1000 contact discharges according to the IEC 61000-4-2 model and far exceeds the specified level 4 (8 kV contact discharge).

## 2. Pinning information

**Table 2. Pinning**

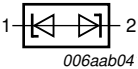
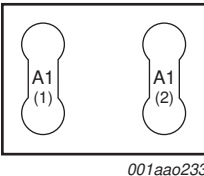
Pin	Description	Simplified outline	Graphic symbol
1	cathode (diode 1)	[1]	
2	cathode (diode 2)		

- [1] The device is electrically and mechanically symmetrical. Thus no marking is needed.

## 3. Ordering information

**Table 3. Ordering information**

Type number	Package		Version
	Name	Description	
IP4302CX2/A	WLCSP2	wafer level chip-size package; 2 bumps (A1-A1)	IP4302CX2/A

## 4. Limiting values

**Table 4. Limiting values**

In accordance with the Absolute Maximum Rating System (IEC 60134).

Symbol	Parameter	Conditions	Min	Max	Unit	
V <sub>ESD</sub>	electrostatic discharge voltage	contact discharge	[1][2] -15	+15	kV	
		air discharge	-15	+15	kV	
		IEC 61000-4-2 level 4				
		contact discharge	-8	+8	kV	
		air discharge	-15	+15	kV	
		MIL-STD-883D (method 3015) HBM	-4	+4	kV	
T <sub>j</sub>	junction temperature		-	150	°C	
T <sub>amb</sub>	ambient temperature		-35	+85	°C	
T <sub>stg</sub>	storage temperature		-65	+150	°C	

[1] Device is qualified with 1000 pulses of ±15 kV contact discharges each, according to the IEC 61000-4-2 model and far exceeds the specified level 4 (8 kV contact discharge).

[2] A special robust test is performed stressing the devices with ≥ 1000 contact discharges according to the IEC 61000-4-2 model and far exceeds the specified level 4 (8 kV contact discharge).

## 5. Characteristics

**Table 5. Characteristics**

T<sub>amb</sub> = 25 °C; unless otherwise specified.

Symbol	Parameter	Conditions	Min	Typ	Max	Unit
I <sub>LR</sub>	reverse leakage current	V <sub>RWM</sub> = 5 V	-	-	20	nA
		V <sub>RWM</sub> = -5 V	-20	-	-	nA
V <sub>BR</sub>	breakdown voltage	I <sub>R</sub> = 1 mA	14.0	16.5	-	V
		I <sub>R</sub> = -1 mA	-	-16.5	-14.0	V
C <sub>d</sub>	diode capacitance	f = 1 MHz; V <sub>R</sub> = 0 V	-	-	10	pF

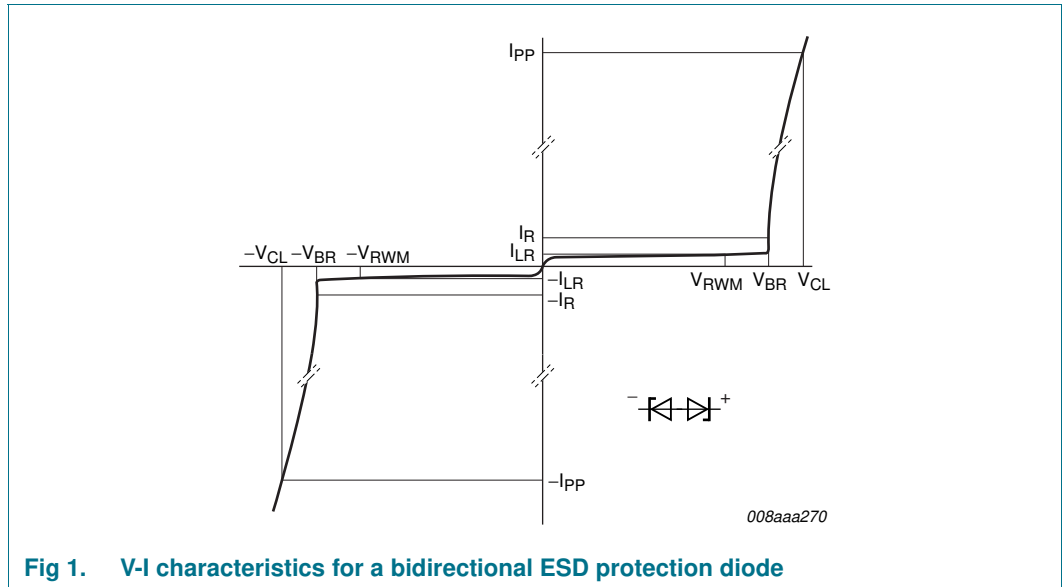

Fig 1. V-I characteristics for a bidirectional ESD protection diode

## 6. Application information

The IP4302CX2/A is designed for the protection of one bidirectional data or signal line from the damage caused by ESD. The device may be used on lines where the signal polarities are both, positive and negative with respect to ground.

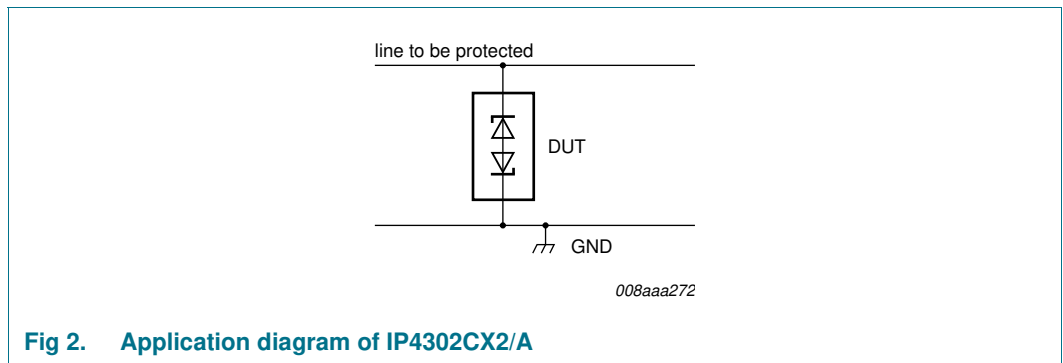

Fig 2. Application diagram of IP4302CX2/A

### 6.1 Printed-Circuit Board (PCB) layout and protection device placement

PCB layout is critical for the suppression of ESD and Electric Fast Transient (EFT). The following guidelines are recommended:

1. Place the device as close as possible to the input terminal or connector
2. The path length between the device and the protected line should be minimized
3. Keep parallel signal paths to a minimum
4. Avoid running protected conductors in parallel with unprotected conductors
5. Minimize all PCB conductive loops including power and ground loops
6. Minimize the length of the transient return path to ground
7. Avoid using shared transient return paths to a common ground point

- 8. Ground planes should be used whenever possible; for multilayer PCBs use ground vias

## 7. Package outline

WLCSP2: wafer level chip-size package; 2 bumps (A1-A1)

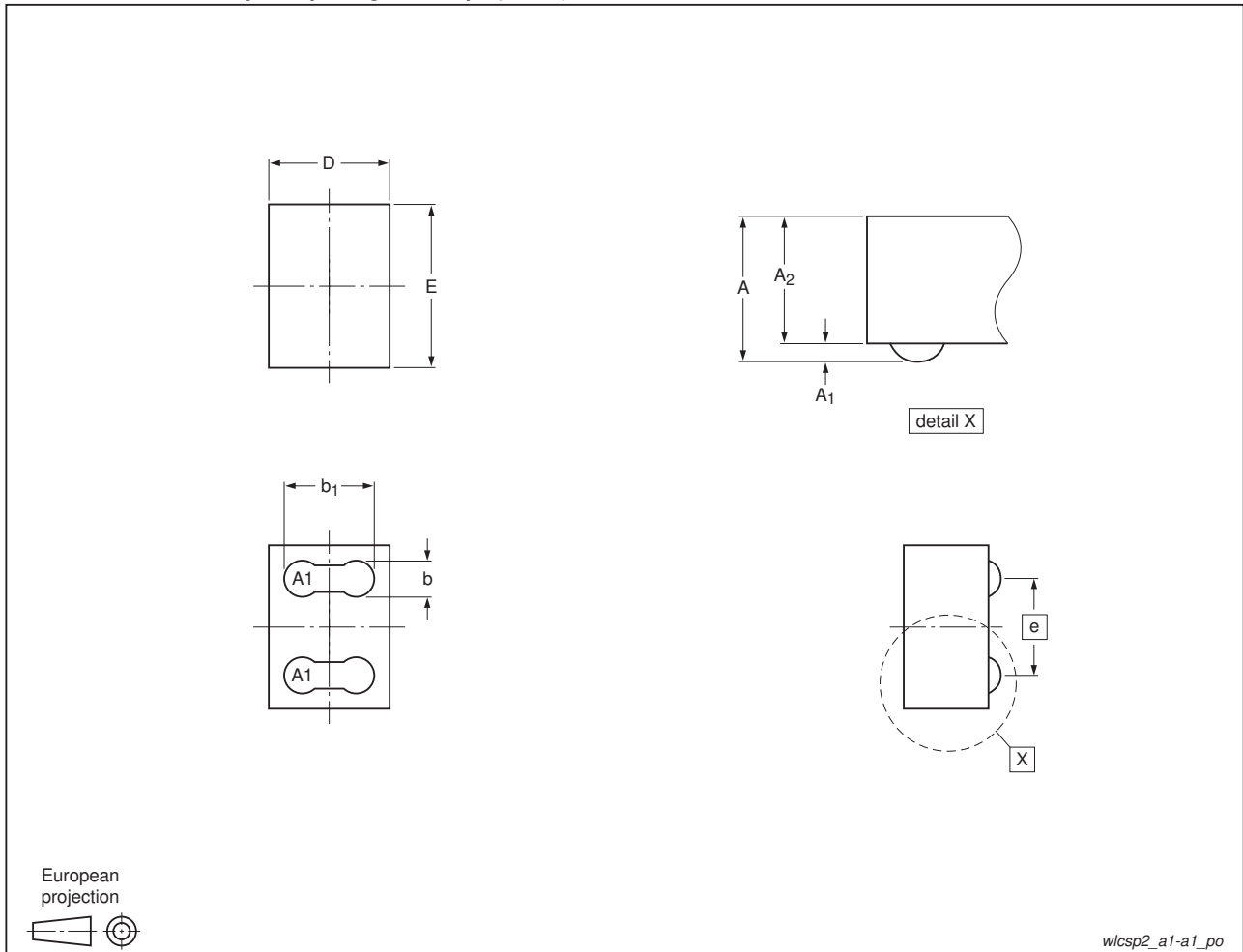

Fig 3. Package outline IP4302CX2/A (WLCSP2)

Table 6. Dimensions for Figure 3

Symbol	Min	Typ	Max	Unit
A	0.37	0.40	0.43	mm
A <sub>1</sub>	0.05	0.06	0.07	mm
A <sub>2</sub>	0.32	0.34	0.36	mm
b	-	0.14	-	mm
b <sub>1</sub>	-	0.35	-	mm
D	0.49	0.52	0.55	mm
E	0.67	0.70	0.73	mm
e	-	0.4	-	mm

## 8. Soldering

### 8.1 Reflow soldering recommendation

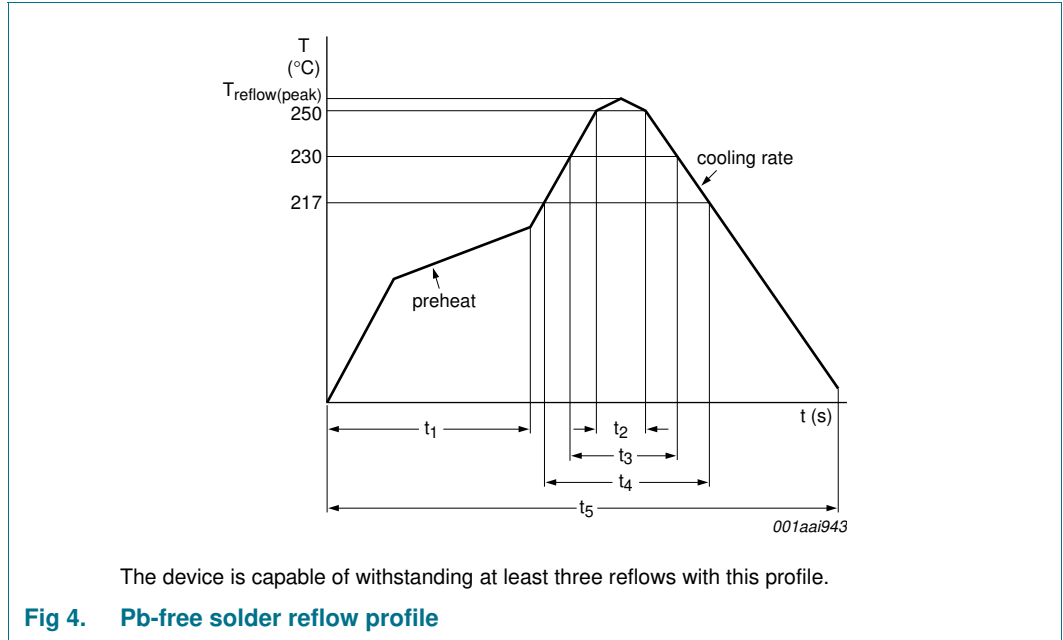

**Table 7. Characteristics**

Symbol	Parameter	Conditions	Min	Typ	Max	Unit
$T_{\text{reflow(peak)}}$	peak reflow temperature		230	-	260	°C
$t_1$	time 1	soak time	60	-	180	s
$t_2$	time 2	time during $T \geq 250 \text{ }^\circ\text{C}$	-	-	30	s
$t_3$	time 3	time during $T \geq 230 \text{ }^\circ\text{C}$	10	-	50	s
$t_4$	time 4	time during $T > 217 \text{ }^\circ\text{C}$	30	-	150	s
$t_5$	time 5		-	-	540	s
$dT/dt$	rate of change of temperature	cooling rate	-	-	-6	°C/s
		preheat	2.5	-	4.0	°C/s



## 9. Abbreviations

Table 8. Abbreviations

Acronym	Description
DUT	Device Under Test
EFT	Electric Fast Transient
ESD	ElectroStatic Discharge
HBM	Human Body Model
PCB	Printed-Circuit Board
RoHS	Restriction of Hazardous Substances
SIM	Subscriber Identity Module
WLCSP	Wafer-Level Chip-Scale Package

## 10. Revision history

Table 9. Revision history

Document ID	Release date	Data sheet status	Change notice	Supersedes
IP4302CX2_A v.1	20111128	Product data sheet	-	-

## 11. Legal information

### 11.1 Data sheet status

Document status <sup>[1][2]</sup>	Product status <sup>[3]</sup>	Definition
Objective [short] data sheet	Development	This document contains data from the objective specification for product development.
Preliminary [short] data sheet	Qualification	This document contains data from the preliminary specification.
Product [short] data sheet	Production	This document contains the product specification.

[1] Please consult the most recently issued document before initiating or completing a design.

[2] The term 'short data sheet' is explained in section "Definitions".

[3] The product status of device(s) described in this document may have changed since this document was published and may differ in case of multiple devices. The latest product status information is available on the Internet at URL <http://www.nxp.com>.

### 11.2 Definitions

**Draft** — The document is a draft version only. The content is still under internal review and subject to formal approval, which may result in modifications or additions. NXP Semiconductors does not give any representations or warranties as to the accuracy or completeness of information included herein and shall have no liability for the consequences of use of such information.

**Short data sheet** — A short data sheet is an extract from a full data sheet with the same product type number(s) and title. A short data sheet is intended for quick reference only and should not be relied upon to contain detailed and full information. For detailed and full information see the relevant full data sheet, which is available on request via the local NXP Semiconductors sales office. In case of any inconsistency or conflict with the short data sheet, the full data sheet shall prevail.

**Product specification** — The information and data provided in a Product data sheet shall define the specification of the product as agreed between NXP Semiconductors and its customer, unless NXP Semiconductors and customer have explicitly agreed otherwise in writing. In no event however, shall an agreement be valid in which the NXP Semiconductors product is deemed to offer functions and qualities beyond those described in the Product data sheet.

### 11.3 Disclaimers

**Limited warranty and liability** — Information in this document is believed to be accurate and reliable. However, NXP Semiconductors does not give any representations or warranties, expressed or implied, as to the accuracy or completeness of such information and shall have no liability for the consequences of use of such information.

In no event shall NXP Semiconductors be liable for any indirect, incidental, punitive, special or consequential damages (including - without limitation - lost profits, lost savings, business interruption, costs related to the removal or replacement of any products or rework charges) whether or not such damages are based on tort (including negligence), warranty, breach of contract or any other legal theory.

Notwithstanding any damages that customer might incur for any reason whatsoever, NXP Semiconductors' aggregate and cumulative liability towards customer for the products described herein shall be limited in accordance with the *Terms and conditions of commercial sale* of NXP Semiconductors.

**Right to make changes** — NXP Semiconductors reserves the right to make changes to information published in this document, including without limitation specifications and product descriptions, at any time and without notice. This document supersedes and replaces all information supplied prior to the publication hereof.

**Suitability for use** — NXP Semiconductors products are not designed, authorized or warranted to be suitable for use in life support, life-critical or safety-critical systems or equipment, nor in applications where failure or

malfunction of an NXP Semiconductors product can reasonably be expected to result in personal injury, death or severe property or environmental damage. NXP Semiconductors accepts no liability for inclusion and/or use of NXP Semiconductors products in such equipment or applications and therefore such inclusion and/or use is at the customer's own risk.

**Applications** — Applications that are described herein for any of these products are for illustrative purposes only. NXP Semiconductors makes no representation or warranty that such applications will be suitable for the specified use without further testing or modification.

Customers are responsible for the design and operation of their applications and products using NXP Semiconductors products, and NXP Semiconductors accepts no liability for any assistance with applications or customer product design. It is customer's sole responsibility to determine whether the NXP Semiconductors product is suitable and fit for the customer's applications and products planned, as well as for the planned application and use of customer's third party customer(s). Customers should provide appropriate design and operating safeguards to minimize the risks associated with their applications and products.

NXP Semiconductors does not accept any liability related to any default, damage, costs or problem which is based on any weakness or default in the customer's applications or products, or the application or use by customer's third party customer(s). Customer is responsible for doing all necessary testing for the customer's applications and products using NXP Semiconductors products in order to avoid a default of the applications and the products or of the application or use by customer's third party customer(s). NXP does not accept any liability in this respect.

**Limiting values** — Stress above one or more limiting values (as defined in the Absolute Maximum Ratings System of IEC 60134) will cause permanent damage to the device. Limiting values are stress ratings only and (proper) operation of the device at these or any other conditions above those given in the Recommended operating conditions section (if present) or the Characteristics sections of this document is not warranted. Constant or repeated exposure to limiting values will permanently and irreversibly affect the quality and reliability of the device.

**Terms and conditions of commercial sale** — NXP Semiconductors products are sold subject to the general terms and conditions of commercial sale, as published at <http://www.nxp.com/profile/terms>, unless otherwise agreed in a valid written individual agreement. In case an individual agreement is concluded only the terms and conditions of the respective agreement shall apply. NXP Semiconductors hereby expressly objects to applying the customer's general terms and conditions with regard to the purchase of NXP Semiconductors products by customer.

**No offer to sell or license** — Nothing in this document may be interpreted or construed as an offer to sell products that is open for acceptance or the grant, conveyance or implication of any license under any copyrights, patents or other industrial or intellectual property rights.

**Export control** — This document as well as the item(s) described herein may be subject to export control regulations. Export might require a prior authorization from competent authorities.

**Quick reference data** — The Quick reference data is an extract of the product data given in the Limiting values and Characteristics sections of this document, and as such is not complete, exhaustive or legally binding.

**Non-automotive qualified products** — Unless this data sheet expressly states that this specific NXP Semiconductors product is automotive qualified, the product is not suitable for automotive use. It is neither qualified nor tested in accordance with automotive testing or application requirements. NXP Semiconductors accepts no liability for inclusion and/or use of non-automotive qualified products in automotive equipment or applications.

In the event that customer uses the product for design-in and use in automotive applications to automotive specifications and standards, customer (a) shall use the product without NXP Semiconductors' warranty of the product for such automotive applications, use and specifications, and (b) whenever customer uses the product for automotive applications beyond NXP Semiconductors' specifications such use shall be solely at customer's

own risk, and (c) customer fully indemnifies NXP Semiconductors for any liability, damages or failed product claims resulting from customer design and use of the product for automotive applications beyond NXP Semiconductors' standard warranty and NXP Semiconductors' product specifications.

**ESD protection devices** — These products are only intended for protection against ElectroStatic Discharge (ESD) pulses and are not intended for any other usage including, without limitation, voltage regulation applications. NXP Semiconductors accepts no liability for use in such applications and therefore such use is at the customer's own risk.

## 11.4 Trademarks

Notice: All referenced brands, product names, service names and trademarks are the property of their respective owners.

## 12. Contact information

For more information, please visit: <http://www.nxp.com>

For sales office addresses, please send an email to: [salesaddresses@nxp.com](mailto:salesaddresses@nxp.com)

### 13. Contents

<b>1</b>	<b>Product profile</b> .....	<b>1</b>
1.1	General description .....	1
1.2	Features and benefits .....	1
1.3	Applications .....	1
1.4	Quick reference data .....	2
<b>2</b>	<b>Pinning information</b> .....	<b>2</b>
<b>3</b>	<b>Ordering information</b> .....	<b>2</b>
<b>4</b>	<b>Limiting values</b> .....	<b>3</b>
<b>5</b>	<b>Characteristics</b> .....	<b>3</b>
<b>6</b>	<b>Application information</b> .....	<b>4</b>
6.1	Printed-Circuit Board (PCB) layout and protection device placement .....	4
<b>7</b>	<b>Package outline</b> .....	<b>5</b>
<b>8</b>	<b>Soldering</b> .....	<b>6</b>
8.1	Reflow soldering recommendation .....	6
<b>9</b>	<b>Abbreviations</b> .....	<b>7</b>
<b>10</b>	<b>Revision history</b> .....	<b>7</b>
<b>11</b>	<b>Legal information</b> .....	<b>8</b>
11.1	Data sheet status .....	8
11.2	Definitions .....	8
11.3	Disclaimers .....	8
11.4	Trademarks .....	9
<b>12</b>	<b>Contact information</b> .....	<b>9</b>
<b>13</b>	<b>Contents</b> .....	<b>10</b>

Please be aware that important notices concerning this document and the product(s) described herein, have been included in section 'Legal information'.

© NXP B.V. 2011.

All rights reserved.

For more information, please visit: <http://www.nxp.com>

For sales office addresses, please send an email to: [salesaddresses@nxp.com](mailto:salesaddresses@nxp.com)

Date of release: 28 November 2011

Document identifier: IP4302CX2\_A