



Chipsmall Limited consists of a professional team with an average of over 10 year of expertise in the distribution of electronic components. Based in Hongkong, we have already established firm and mutual-benefit business relationships with customers from,Europe,America and south Asia,supplying obsolete and hard-to-find components to meet their specific needs.

With the principle of “Quality Parts,Customers Priority,Honest Operation,and Considerate Service”,our business mainly focus on the distribution of electronic components. Line cards we deal with include Microchip,ALPS,ROHM,Xilinx,Pulse,ON,Everlight and Freescale. Main products comprise IC,Modules,Potentiometer,IC Socket,Relay,Connector.Our parts cover such applications as commercial,industrial, and automotives areas.

We are looking forward to setting up business relationship with you and hope to provide you with the best service and solution. Let us make a better world for our industry!



Contact us

Tel: +86-755-8981 8866 Fax: +86-755-8427 6832

Email & Skype: info@chipsmall.com Web: www.chipsmall.com

Address: A1208, Overseas Decoration Building, #122 Zhenhua RD., Futian, Shenzhen, China



Important notice

Dear Customer,

On 7 February 2017 the former NXP Standard Product business became a new company with the tradename **Nexperia**. Nexperia is an industry leading supplier of Discrete, Logic and PowerMOS semiconductors with its focus on the automotive, industrial, computing, consumer and wearable application markets

In data sheets and application notes which still contain NXP or Philips Semiconductors references, use the references to Nexperia, as shown below.

Instead of <http://www.nxp.com>, <http://www.philips.com/> or <http://www.semiconductors.philips.com/>, use <http://www.nexperia.com>

Instead of sales.addresses@www.nxp.com or sales.addresses@www.semiconductors.philips.com, use salesaddresses@nexperia.com (email)

Replace the copyright notice at the bottom of each page or elsewhere in the document, depending on the version, as shown below:

- © NXP N.V. (year). All rights reserved or © Koninklijke Philips Electronics N.V. (year). All rights reserved

Should be replaced with:

- © **Nexperia B.V. (year). All rights reserved.**

If you have any questions related to the data sheet, please contact our nearest sales office via e-mail or telephone (details via salesaddresses@nexperia.com). Thank you for your cooperation and understanding,

Kind regards,

Team Nexperia

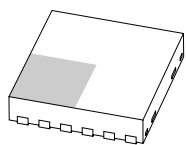

IP4791CZ12

HDMI ESD protection, level shifter and backdrive protection

Rev. 3 — 7 January 2011

Product data sheet

1. General description

The IP4791CZ12 is designed to protect mobile High-Definition Multimedia Interface (HDMI) transmitter interfaces. It includes level shifting for the Data Display Channel (DDC), Consumer Electronic Control (CEC), hot plug signal and backdrive protection. In addition, all signals are protected by high-level ElectroStatic Discharge (ESD) protection diodes.

The level shifting function is required to protect the I/Os against overvoltages when the transmitter operates at a supply voltage lower than the external devices. The IP4791CZ12 contains active buffers to provide the level shifting function, hot plug detect input and the CEC pull-up current source.

The ESD protection diodes provide protection from ESD voltages up to ± 8 kV, according to IEC 61000-4-2, level 4.

2. Features and benefits

- HDMI 1.3 compliant
- Pb-free, Restriction of Hazardous Substances (RoHS) compliant and free of halogen and antimony (Dark Green compliant)
- Robust ESD protection without degradation after multiple ESD strikes
- Low leakage even after several hundred ESD discharges
- Bidirectional level shifting buffer provided for DDC clock and data channels
- Backdrive protection
- Power management
- CEC pull-up current source and level shifting buffer
- Hot plug detect module with pull-down resistor
- Matched 0.4 mm trace spacing for HDMI type C connector

3. Applications

The IP4791CZ12 can be used with a range of HDMI transmitter devices including:

- Personal computer
- Notebook
- Mobile phone
- DV camcorder
- Digital still camera
- MP3 player



4. Ordering information

Table 1. Ordering information

Type number	Package		Version
	Name	Description	
IP4791CZ12	HXSON12	plastic, thermal enhanced extremely thin small outline package; no leads; 12 terminals; body 2.1 × 2.5 × 0.5 mm	SOT1156-1

5. Functional diagram

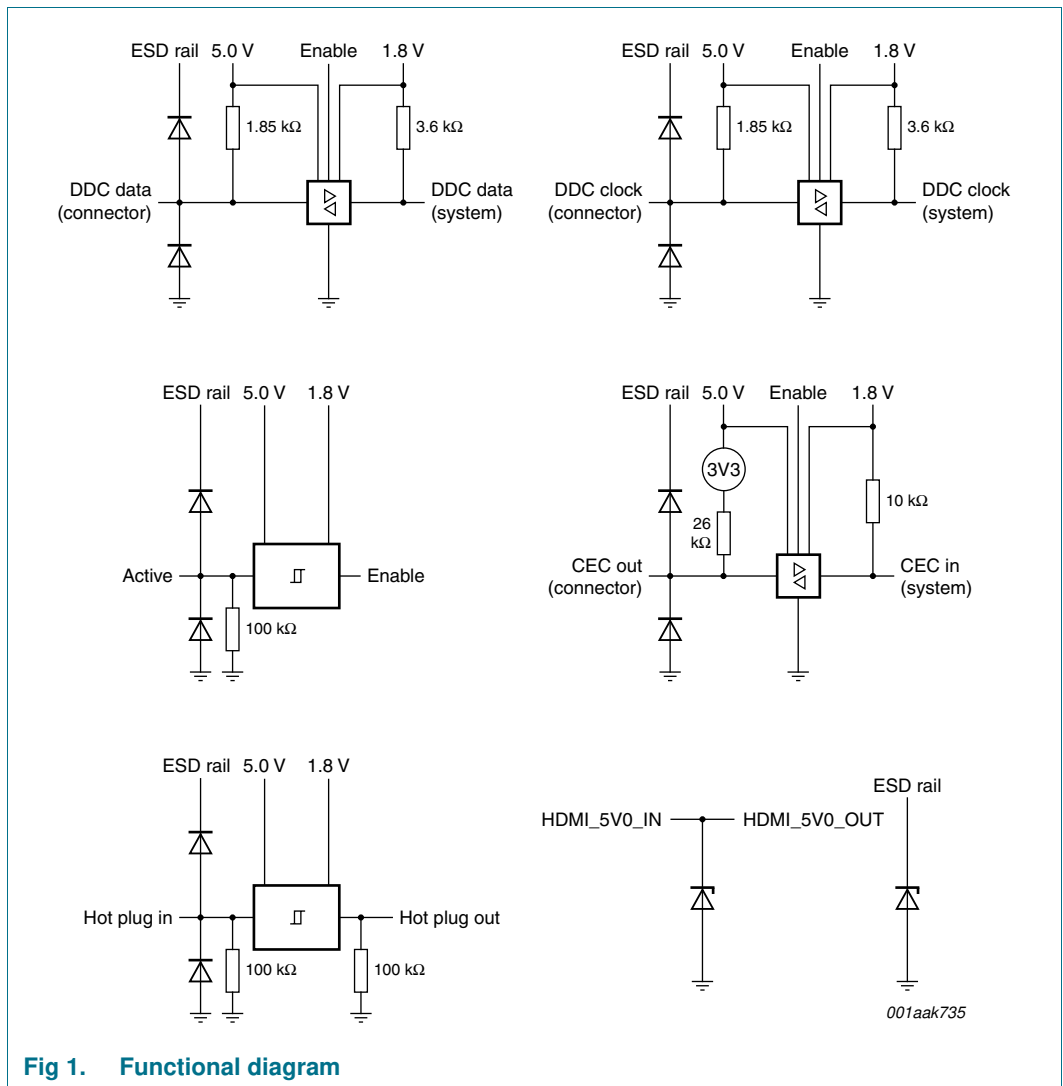
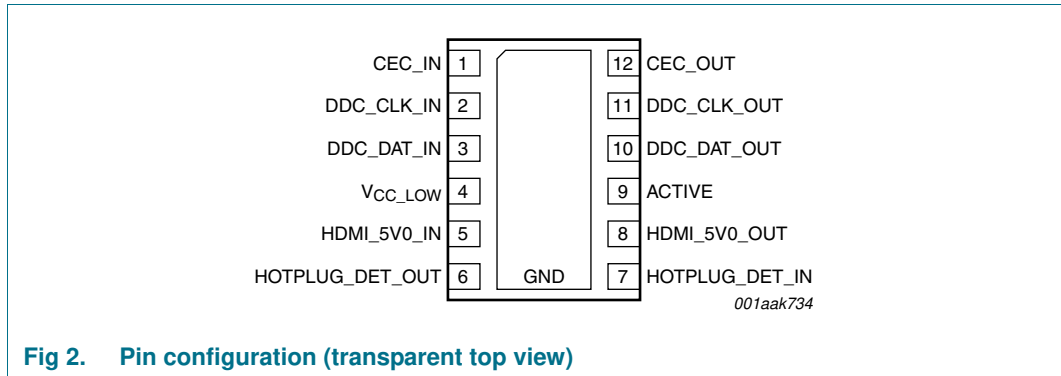

Fig 1. Functional diagram

6. Pinning information

6.1 Pinning



6.2 Pin description

Table 2. Pin description

Symbol	Pin	Description
CEC_IN	1	CEC system side
DDC_CLK_IN	2	DDC clock system side
DDC_DAT_IN	3	DDC data system side
V _{CC_LOW}	4	supply voltage, low voltage side for level shifting
HDMI_5V0_IN	5	5 V line from main supply
HOTPLUG_DET_OUT	6	hot plug detect system side
HOTPLUG_DET_IN	7	hot plug detect connector side
HDMI_5V0_OUT	8	5 V line to HDMI connector
ACTIVE	9	power saving mode
DDC_DAT_OUT	10	DDC data connector side
DDC_CLK_OUT	11	DDC clock connector side
CEC_OUT	12	CEC connector side
GND	Pad	ground

7. Limiting values

Table 3. Limiting values

In accordance with the Absolute Maximum Rating System (IEC 60134).

Symbol	Parameter	Conditions	Min	Max	Unit
V _{ESD}	electrostatic discharge voltage	signal pins to ground			
		at HDMI/DVI connector side	[1] -	±10	kV
		all pins	[2] -	±200	V
		all pins	[3] -	±2	kV
V _{CC}	supply voltage		GND – 0.5	5.5	V
V _I	input voltage		GND – 0.5	5.5	V
P _{tot}	total power dissipation	ACTIVE = HIGH; DDC operating at 100 kHz, 50 % duty cycle; CEC operating at 1 kHz, 50 % duty cycle	[4] -	30	mW
		disable: HDMI cable not connected; ACTIVE = LOW, DDC bus in Idle mode	-	0.2	mW
T _{stg}	storage temperature		-55	+125	°C
T _{amb}	ambient temperature		-40	+85	°C

[1] IEC 61000-4-2, level 4, contact discharge.

[2] Machine Model (MM) according to JESD22-A115-A.

[3] Human Body Model (HBM) according to JESD22-A-J114D.

[4] Including the current through the internal pull-up resistors.

8. Characteristics

Table 4. Supplies

GND = 0 V; T_{amb} = 25 °C; unless otherwise specified.

Symbol	Parameter	Conditions	Min	Typ	Max	Unit
V _{CC(5V0)}	supply voltage (5.0 V)		4.5	5.0	5.5	V
V _{CC(1V8)}	supply voltage (1.8 V)		1.62	1.8	3.63	V

Table 5. Static characteristics

V_{CC(5V0)} = 5.0 V; V_{CC(1V8)} = 1.8 V; GND = 0 V; T_{amb} = 25 °C; unless otherwise specified.

Symbol	Parameter	Conditions	Min	Typ	Max	Unit
HDMI_5V0_OUT						
R _{dyn}	dynamic resistance		[1]			
		positive transient	-	0.6	-	Ω
		negative transient	-	0.4	-	Ω
V _{CL(ch)trt(pos)}	positive transient channel clamping voltage	V _{ESD} = 8 kV, t _p = 100 ns	[2] -	8.0	-	V
ACTIVE						
V _{IH}	HIGH-level input voltage		[3] 1.2	-	-	V
V _{IL}	LOW-level input voltage		-	-	0.8	V
R _{pd}	pull-down resistance		60	100	140	kΩ

Table 5. Static characteristics ...continued

$V_{CC(5V0)} = 5.0\text{ V}$; $V_{CC(1V8)} = 1.8\text{ V}$; $GND = 0\text{ V}$; $T_{amb} = 25\text{ °C}$; unless otherwise specified.

Symbol	Parameter	Conditions	Min	Typ	Max	Unit
DDC buffer - connector side (pin 10 and pin 11) [3]						
V_{IH}	HIGH-level input voltage		$0.5 \times V_{CC(5V0)}$	-	5.5	V
V_{IL}	LOW-level input voltage		-0.5	-	$0.3 \times V_{CC(5V0)}$	V
V_{IK}	input clamping voltage	$I_I = -18\text{ mA}$	-	-1.0	-	V
V_{OL}	LOW-level output voltage	internal pull-down current	-	100	200	mV
V_{OH}	HIGH-level output voltage		[4] $V_{CC(5V0)} - 0.02$	-	$V_{CC(5V0)} + 0.02$	V
C_{IO}	input/output capacitance	$V_{CC(5V0)} = 0\text{ V}$; $V_{CC(1V8)} = 0\text{ V}$; $V_{bias} = 2.5\text{ V}$; AC input = $3.5\text{ V}_{(p-p)}$; $f = 100\text{ kHz}$	[4] -	8	10	pF
R_{pu}	pull-up resistance		1.6	1.8	2.0	k Ω
DDC buffer - system side (pin 2 and pin 3) [3]						
V_{IH}	HIGH-level input voltage		$0.26 \times V_{CC(1V8)}$	-	-	V
V_{IL}	LOW-level input voltage		-	-	$0.20 \times V_{CC(1V8)}$	V
V_{IK}	input clamping voltage	$I_I = -18\text{ mA}$	-	-1.0	-	V
V_{OL}	LOW-level output voltage		-	-	$0.28 \times V_{CC(1V8)}$	V
V_{OH}	HIGH-level output voltage		[4] $V_{CC(1V8)} - 0.02$	-	$V_{CC(1V8)} + 0.02$	V
C_{IO}	input/output capacitance	$V_{CC(5V0)} = 0\text{ V}$; $V_{CC(1V8)} = 0\text{ V}$; $V_{bias} = 2.5\text{ V}$; AC input = $3.5\text{ V}_{(p-p)}$; $f = 100\text{ kHz}$	[4] -	6	8	pF
R_{pu}	pull-up resistance		3.2	3.65	4.1	k Ω
CEC_OUT [3]						
V_{IH}	HIGH-level input voltage		2.0	-	-	V
V_{IL}	LOW-level input voltage		-	-	0.80	V
V_{OH}	HIGH-level output voltage		2.88	3.3	3.63	V
V_{OL}	LOW-level output voltage	$I_{OL} = 1.5\text{ mA}$	-	100	200	mV
C_{IO}	input/output capacitance	$V_{CC(5V0)} = 0\text{ V}$; $V_{CC(1V8)} = 0\text{ V}$; $V_{bias} = 2.5\text{ V}$; AC input = $3.5\text{ V}_{(p-p)}$; $f = 100\text{ kHz}$	[4] -	8	10	pF
R_{pu}	pull-up resistance		23.4	26.0	28.6	k Ω

Table 5. Static characteristics ...continued

$V_{CC(5V0)} = 5.0\text{ V}$; $V_{CC(1V8)} = 1.8\text{ V}$; $GND = 0\text{ V}$; $T_{amb} = 25\text{ °C}$; unless otherwise specified.

Symbol	Parameter	Conditions	Min	Typ	Max	Unit
CEC_IN [3]						
V_{IH}	HIGH-level input voltage		$0.26 \times V_{CC(1V8)}$	-	-	V
V_{IL}	LOW-level input voltage		-	-	$0.20 \times V_{CC(1V8)}$	V
V_{OH}	HIGH-level output voltage		[4] $V_{CC(1V8)} - 0.02$	-	$V_{CC(1V8)} + 0.02$	V
V_{OL}	LOW-level output voltage		-	-	$0.28 \times V_{CC(1V8)}$	V
C_{IO}	input/output capacitance	$V_{CC(5V0)} = 0\text{ V}$; $V_{CC(1V8)} = 0\text{ V}$; $V_{bias} = 2.5\text{ V}$; AC input = $3.5\text{ V}_{(p-p)}$; $f = 100\text{ kHz}$	[4] -	6	7	pF
R_{pu}	pull-up resistance		8.5	10.0	11.5	k Ω
HOTPLUG_DET_IN [3]						
V_{IH}	HIGH-level input voltage		2.0	-	-	V
V_{IL}	LOW-level input voltage		-	-	0.8	V
R_{pd}	pull-down resistance		60	100	140	k Ω
C_i	input capacitance	$V_{CC(5V0)} = 0\text{ V}$; $V_{CC(1V8)} = 0\text{ V}$; $V_{bias} = 2.5\text{ V}$; AC input = $3.5\text{ V}_{(p-p)}$; $f = 100\text{ kHz}$	[4] -	8	10	pF
HOTPLUG_DET_OUT [3]						
V_{OH}	HIGH-level output voltage	$I_{OL} = 1\text{ mA}$	$0.7 \times V_{CC(1V8)}$	-	-	V
V_{OL}	LOW-level output voltage	$I_{OL} = -1\text{ mA}$	-	200	300	mV
R_{pd}	pull-down resistance		60	100	140	k Ω

[1] ANSI-ESD519.4-2004, ESD sensitivity testing TLP component level method 50 TDR.

[2] According to IEC 61000, level 4, contact discharge.

[3] The device is active if the input voltage at pin ACTIVE is above the HIGH level.

[4] This parameter is guaranteed by design.

Table 6. Dynamic characteristics

$V_{CC(5V0)} = 5.0\text{ V}$; $V_{CC(1V8)} = 1.8\text{ V}$; $GND = 0\text{ V}$; $T_{amb} = 25\text{ °C}$; unless otherwise specified.

Symbol	Parameter	Conditions	Min	Typ	Max	Unit
DDC_DAT_IN, DDC_CLK_IN, DDC_DAT_OUT, DDC_CLK_OUT						
t_{PLH}	LOW to HIGH propagation delay	system side to connector side Figure 3	[1] -	80	-	ns
t_{PHL}	HIGH to LOW propagation delay	system side to connector side Figure 3	[1] -	60	-	ns
t_{PLH}	LOW to HIGH propagation delay	connector side to system side Figure 4	[1] -	120	-	ns
t_{PHL}	HIGH to LOW propagation delay	connector side to system side Figure 4	[1] -	80	-	ns
t_{TLH}	LOW to HIGH transition time	connector side Figure 5	[1] -	150	-	ns
t_{THL}	HIGH to LOW transition time	connector side Figure 5	[1] -	100	-	ns
t_{TLH}	LOW to HIGH transition time	system side Figure 6	[1] -	250	-	ns
t_{THL}	HIGH to LOW transition time	system side Figure 6	[1] -	80	-	ns

[1] All dynamic measurements are done with a 50 pF load. Rise times are determined by internal pull-up resistors.

9. AC waveforms

9.1 DDC propagation delay

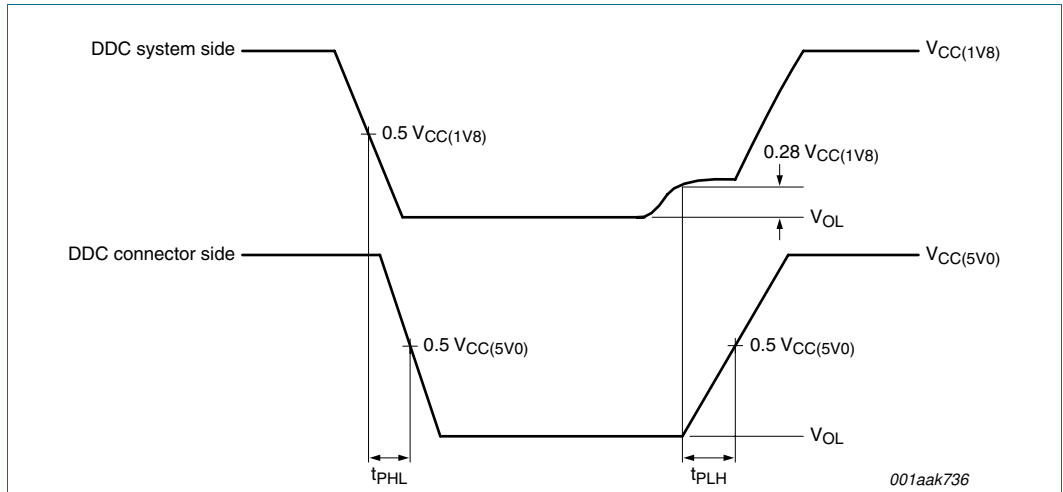

Fig 3. Propagation delay DDC, DDC system side to DDC connector side

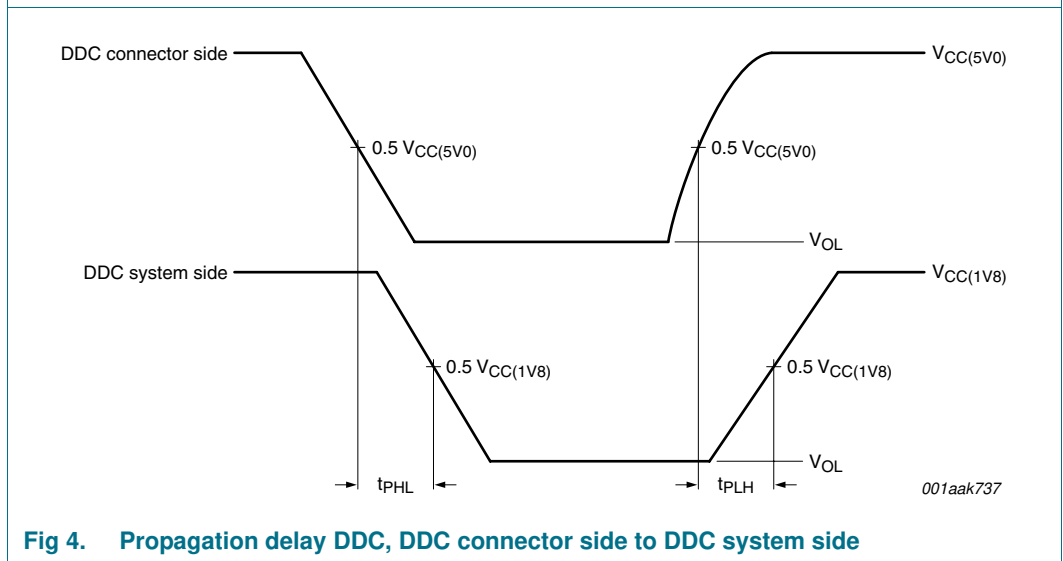

Fig 4. Propagation delay DDC, DDC connector side to DDC system side

9.2 DDC transition time

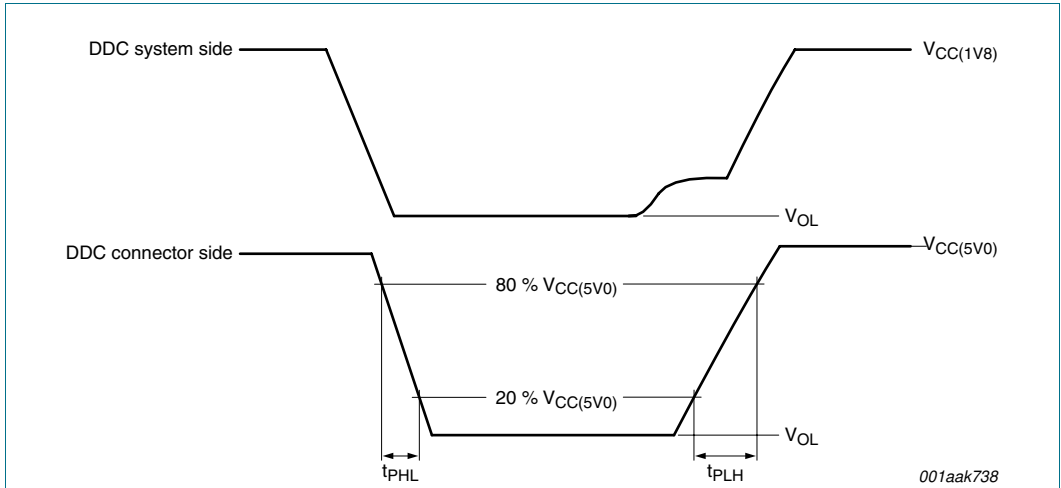

Fig 5. Transition time DDC connector side

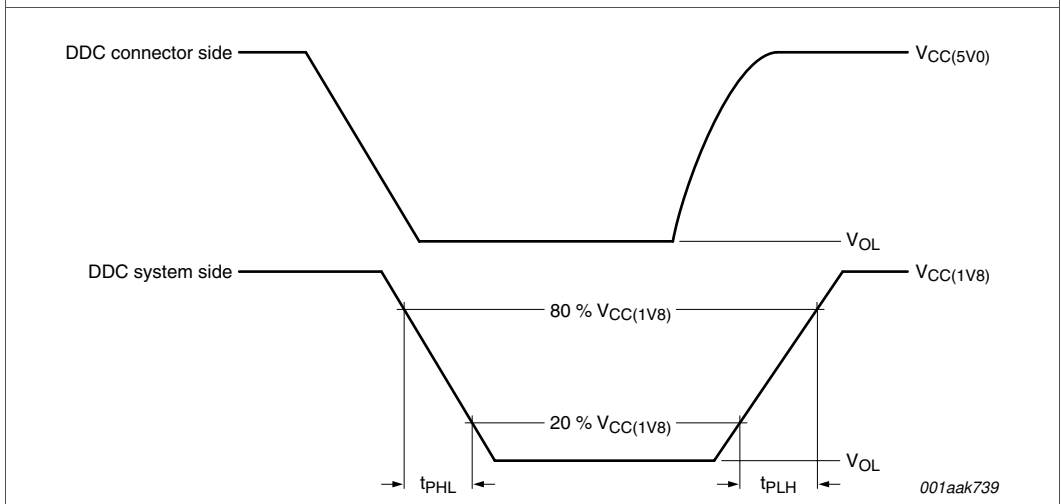

Fig 6. Transition time DDC system side

10. Application information

10.1 HDMI source

The IP4791CZ12 simplifies the application of a mobile HDMI source.

No external components are needed for the application to adapt the HDMI port to the HDMI transmitter.

Note: The 5 V supply voltage must be in the range 4.8 V to 5.3 V to pass the HDMI compliance test.

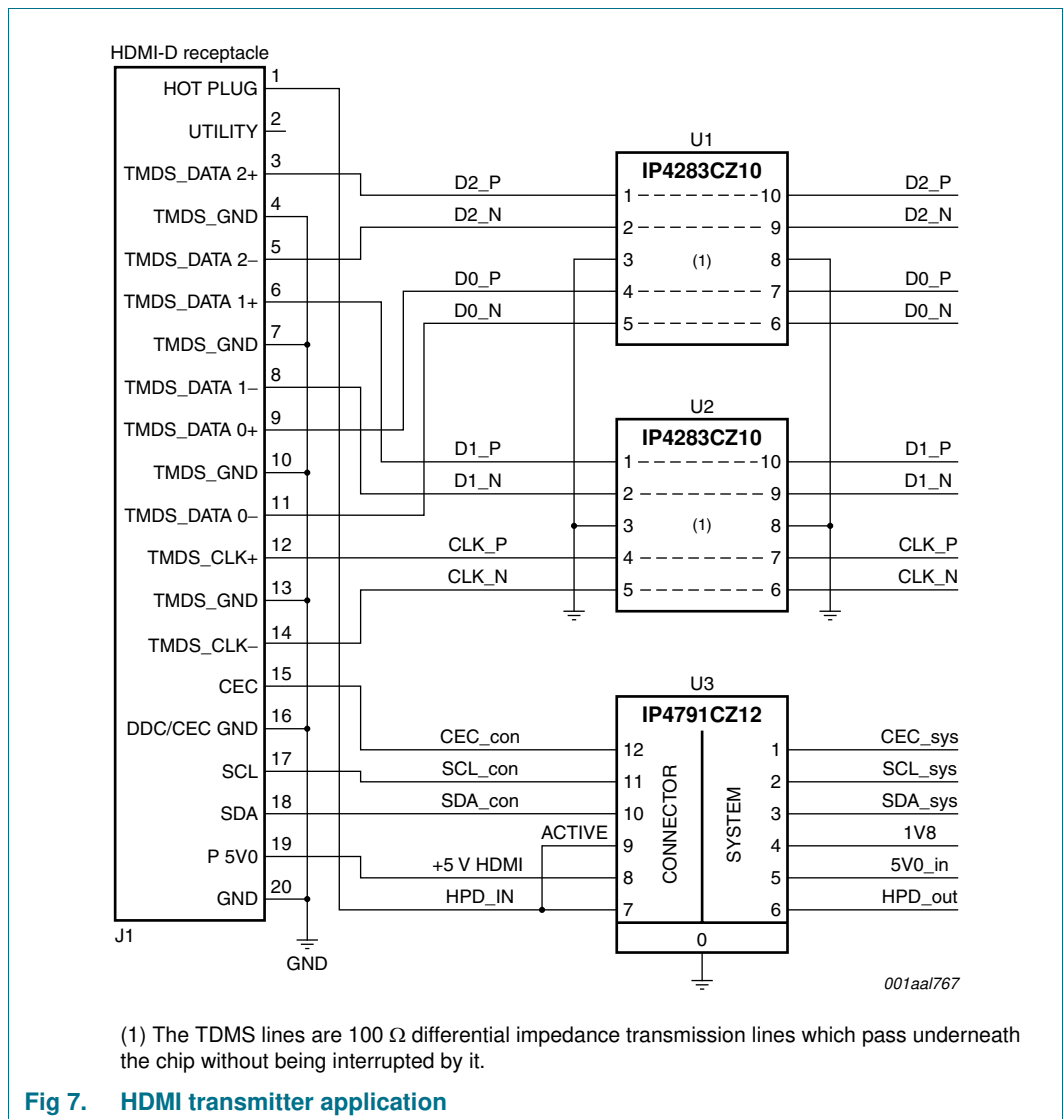

The ACTIVE pin is enabling the IP4791CZ12 with a voltage above 1.2 V. Connecting the ACTIVE pin to the HOT PLUG line will enable the IP4791CZ12 automatically if any HDMI sink is connected to the HDMI port and disable (switch to power-saving mode of the IP4791CZ12) when no HDMI sink is connecting to the HDMI port.

11. Package outline

HXSON12: plastic, thermal enhanced extremely thin small outline package; no leads;
12 terminals; body 2.1 x 2.5 x 0.5 mm

SOT1156-1

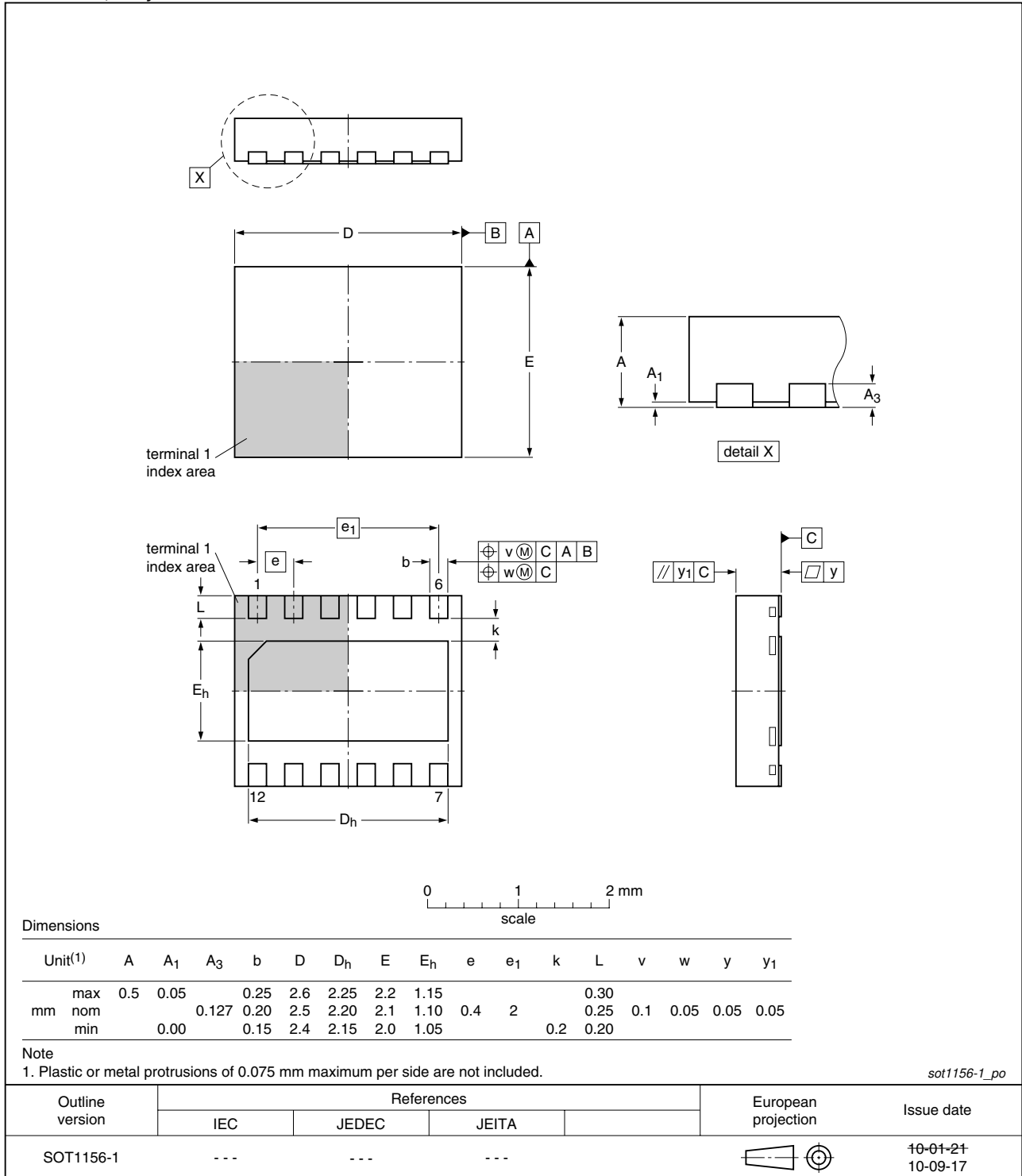

Fig 8. Package outline SOT1156-1 (HXSON12)

12. Soldering of SMD packages

This text provides a very brief insight into a complex technology. A more in-depth account of soldering ICs can be found in Application Note *AN10365 "Surface mount reflow soldering description"*.

12.1 Introduction to soldering

Soldering is one of the most common methods through which packages are attached to Printed Circuit Boards (PCBs), to form electrical circuits. The soldered joint provides both the mechanical and the electrical connection. There is no single soldering method that is ideal for all IC packages. Wave soldering is often preferred when through-hole and Surface Mount Devices (SMDs) are mixed on one printed wiring board; however, it is not suitable for fine pitch SMDs. Reflow soldering is ideal for the small pitches and high densities that come with increased miniaturization.

12.2 Wave and reflow soldering

Wave soldering is a joining technology in which the joints are made by solder coming from a standing wave of liquid solder. The wave soldering process is suitable for the following:

- Through-hole components
- Leaded or leadless SMDs, which are glued to the surface of the printed circuit board

Not all SMDs can be wave soldered. Packages with solder balls, and some leadless packages which have solder lands underneath the body, cannot be wave soldered. Also, leaded SMDs with leads having a pitch smaller than ~0.6 mm cannot be wave soldered, due to an increased probability of bridging.

The reflow soldering process involves applying solder paste to a board, followed by component placement and exposure to a temperature profile. Leaded packages, packages with solder balls, and leadless packages are all reflow solderable.

Key characteristics in both wave and reflow soldering are:

- Board specifications, including the board finish, solder masks and vias
- Package footprints, including solder thieves and orientation
- The moisture sensitivity level of the packages
- Package placement
- Inspection and repair
- Lead-free soldering versus SnPb soldering

12.3 Wave soldering

Key characteristics in wave soldering are:

- Process issues, such as application of adhesive and flux, clinching of leads, board transport, the solder wave parameters, and the time during which components are exposed to the wave
- Solder bath specifications, including temperature and impurities

12.4 Reflow soldering

Key characteristics in reflow soldering are:

- Lead-free versus SnPb soldering; note that a lead-free reflow process usually leads to higher minimum peak temperatures (see [Figure 9](#)) than a SnPb process, thus reducing the process window
- Solder paste printing issues including smearing, release, and adjusting the process window for a mix of large and small components on one board
- Reflow temperature profile; this profile includes preheat, reflow (in which the board is heated to the peak temperature) and cooling down. It is imperative that the peak temperature is high enough for the solder to make reliable solder joints (a solder paste characteristic). In addition, the peak temperature must be low enough that the packages and/or boards are not damaged. The peak temperature of the package depends on package thickness and volume and is classified in accordance with [Table 7](#) and [8](#)

Table 7. SnPb eutectic process (from J-STD-020C)

Package thickness (mm)	Package reflow temperature (°C)	
	Volume (mm ³)	
	< 350	≥ 350
< 2.5	235	220
≥ 2.5	220	220

Table 8. Lead-free process (from J-STD-020C)

Package thickness (mm)	Package reflow temperature (°C)		
	Volume (mm ³)		
	< 350	350 to 2000	> 2000
< 1.6	260	260	260
1.6 to 2.5	260	250	245
> 2.5	250	245	245

Moisture sensitivity precautions, as indicated on the packing, must be respected at all times.

Studies have shown that small packages reach higher temperatures during reflow soldering, see [Figure 9](#).

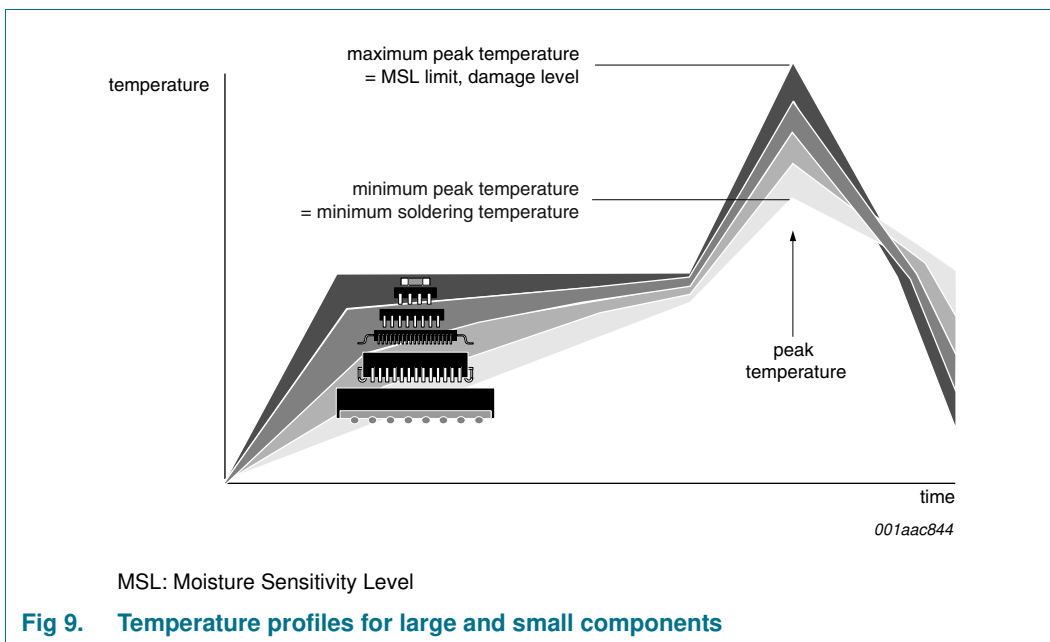

For further information on temperature profiles, refer to Application Note AN10365 “Surface mount reflow soldering description”.

13. Abbreviations

Table 9. Abbreviations

Acronym	Description
CEC	Consumer Electronic Control
DDC	Data Display Channel
DVI	Digital Visual Interface
ESD	ElectroStatic Discharge
HDMI	High-Definition Multimedia Interface
RoHS	Restriction of Hazardous Substances
TDMS	Transition Minimized Differential Signalling
TDR	Time Domain Reflectometer
TLP	Transmission Line Pulse

14. Revision history

Table 10. Revision history

Document ID	Release date	Data sheet status	Change notice	Supersedes
IP4791CZ12 v.3	20110107	Product data sheet	-	IP4791CZ12 v.2
Modifications:		<ul style="list-style-type: none">• Table 3 “Limiting values”: P_{tot} maximum value updated.• Table 5 “Static characteristics”: V_{IK} updated.• Section 10.1 “HDMI source”: enhanced.		
IP4791CZ12 v.2	20101111	Preliminary data sheet	-	IP4791CZ12 v.1
IP4791CZ12 v.1	20100401	Objective data sheet	-	-

15. Legal information

15.1 Data sheet status

Document status ^{[1][2]}	Product status ^[3]	Definition
Objective [short] data sheet	Development	This document contains data from the objective specification for product development.
Preliminary [short] data sheet	Qualification	This document contains data from the preliminary specification.
Product [short] data sheet	Production	This document contains the product specification.

[1] Please consult the most recently issued document before initiating or completing a design.

[2] The term 'short data sheet' is explained in section "Definitions".

[3] The product status of device(s) described in this document may have changed since this document was published and may differ in case of multiple devices. The latest product status information is available on the Internet at URL <http://www.nxp.com>.

15.2 Definitions

Draft — The document is a draft version only. The content is still under internal review and subject to formal approval, which may result in modifications or additions. NXP Semiconductors does not give any representations or warranties as to the accuracy or completeness of information included herein and shall have no liability for the consequences of use of such information.

Short data sheet — A short data sheet is an extract from a full data sheet with the same product type number(s) and title. A short data sheet is intended for quick reference only and should not be relied upon to contain detailed and full information. For detailed and full information see the relevant full data sheet, which is available on request via the local NXP Semiconductors sales office. In case of any inconsistency or conflict with the short data sheet, the full data sheet shall prevail.

Product specification — The information and data provided in a Product data sheet shall define the specification of the product as agreed between NXP Semiconductors and its customer, unless NXP Semiconductors and customer have explicitly agreed otherwise in writing. In no event however, shall an agreement be valid in which the NXP Semiconductors product is deemed to offer functions and qualities beyond those described in the Product data sheet.

15.3 Disclaimers

Limited warranty and liability — Information in this document is believed to be accurate and reliable. However, NXP Semiconductors does not give any representations or warranties, expressed or implied, as to the accuracy or completeness of such information and shall have no liability for the consequences of use of such information.

In no event shall NXP Semiconductors be liable for any indirect, incidental, punitive, special or consequential damages (including - without limitation - lost profits, lost savings, business interruption, costs related to the removal or replacement of any products or rework charges) whether or not such damages are based on tort (including negligence), warranty, breach of contract or any other legal theory.

Notwithstanding any damages that customer might incur for any reason whatsoever, NXP Semiconductors' aggregate and cumulative liability towards customer for the products described herein shall be limited in accordance with the *Terms and conditions of commercial sale* of NXP Semiconductors.

Right to make changes — NXP Semiconductors reserves the right to make changes to information published in this document, including without limitation specifications and product descriptions, at any time and without notice. This document supersedes and replaces all information supplied prior to the publication hereof.

Suitability for use — NXP Semiconductors products are not designed, authorized or warranted to be suitable for use in life support, life-critical or safety-critical systems or equipment, nor in applications where failure or

malfunction of an NXP Semiconductors product can reasonably be expected to result in personal injury, death or severe property or environmental damage. NXP Semiconductors accepts no liability for inclusion and/or use of NXP Semiconductors products in such equipment or applications and therefore such inclusion and/or use is at the customer's own risk.

Applications — Applications that are described herein for any of these products are for illustrative purposes only. NXP Semiconductors makes no representation or warranty that such applications will be suitable for the specified use without further testing or modification.

Customers are responsible for the design and operation of their applications and products using NXP Semiconductors products, and NXP Semiconductors accepts no liability for any assistance with applications or customer product design. It is customer's sole responsibility to determine whether the NXP Semiconductors product is suitable and fit for the customer's applications and products planned, as well as for the planned application and use of customer's third party customer(s). Customers should provide appropriate design and operating safeguards to minimize the risks associated with their applications and products.

NXP Semiconductors does not accept any liability related to any default, damage, costs or problem which is based on any weakness or default in the customer's applications or products, or the application or use by customer's third party customer(s). Customer is responsible for doing all necessary testing for the customer's applications and products using NXP Semiconductors products in order to avoid a default of the applications and the products or of the application or use by customer's third party customer(s). NXP does not accept any liability in this respect.

Limiting values — Stress above one or more limiting values (as defined in the Absolute Maximum Ratings System of IEC 60134) will cause permanent damage to the device. Limiting values are stress ratings only and (proper) operation of the device at these or any other conditions above those given in the Recommended operating conditions section (if present) or the Characteristics sections of this document is not warranted. Constant or repeated exposure to limiting values will permanently and irreversibly affect the quality and reliability of the device.

Terms and conditions of commercial sale — NXP Semiconductors products are sold subject to the general terms and conditions of commercial sale, as published at <http://www.nxp.com/profile/terms>, unless otherwise agreed in a valid written individual agreement. In case an individual agreement is concluded only the terms and conditions of the respective agreement shall apply. NXP Semiconductors hereby expressly objects to applying the customer's general terms and conditions with regard to the purchase of NXP Semiconductors products by customer.

No offer to sell or license — Nothing in this document may be interpreted or construed as an offer to sell products that is open for acceptance or the grant, conveyance or implication of any license under any copyrights, patents or other industrial or intellectual property rights.

Export control — This document as well as the item(s) described herein may be subject to export control regulations. Export might require a prior authorization from national authorities.

Non-automotive qualified products — Unless this data sheet expressly states that this specific NXP Semiconductors product is automotive qualified, the product is not suitable for automotive use. It is neither qualified nor tested in accordance with automotive testing or application requirements. NXP Semiconductors accepts no liability for inclusion and/or use of non-automotive qualified products in automotive equipment or applications.

In the event that customer uses the product for design-in and use in automotive applications to automotive specifications and standards, customer (a) shall use the product without NXP Semiconductors' warranty of the product for such automotive applications, use and specifications, and (b) whenever customer uses the product for automotive applications beyond

NXP Semiconductors' specifications such use shall be solely at customer's own risk, and (c) customer fully indemnifies NXP Semiconductors for any liability, damages or failed product claims resulting from customer design and use of the product for automotive applications beyond NXP Semiconductors' standard warranty and NXP Semiconductors' product specifications.

15.4 Trademarks

Notice: All referenced brands, product names, service names and trademarks are the property of their respective owners.

16. Contact information

For more information, please visit: <http://www.nxp.com>

For sales office addresses, please send an email to: salesaddresses@nxp.com

17. Contents

1	General description	1
2	Features and benefits	1
3	Applications	1
4	Ordering information	2
5	Functional diagram	2
6	Pinning information	3
6.1	Pinning	3
6.2	Pin description	3
7	Limiting values	4
8	Characteristics	4
9	AC waveforms	7
9.1	DDC propagation delay	7
9.2	DDC transition time	8
10	Application information	9
10.1	HDMI source	9
11	Package outline	10
12	Soldering of SMD packages	11
12.1	Introduction to soldering	11
12.2	Wave and reflow soldering	11
12.3	Wave soldering	11
12.4	Reflow soldering	12
13	Abbreviations	13
14	Revision history	14
15	Legal information	15
15.1	Data sheet status	15
15.2	Definitions	15
15.3	Disclaimers	15
15.4	Trademarks	16
16	Contact information	16
17	Contents	17

Please be aware that important notices concerning this document and the product(s) described herein, have been included in section 'Legal information'.

© NXP B.V. 2011.

All rights reserved.

For more information, please visit: <http://www.nxp.com>

For sales office addresses, please send an email to: salesaddresses@nxp.com

Date of release: 7 January 2011

Document identifier: IP4791CZ12